

Distance Sensor

U18T002S01



- Digital and analog output
- IO-Link 1.1
- Stainless steel housing
- Synchronous and multiplex mode

These ultrasonic sensors evaluate the sound reflected from the object. They are capable of detecting almost any object, regardless of material and condition. As such, they are especially well suited for monitoring fill levels of liquids and bulk goods and for detecting transparent objects. The measured value can be read out via IO-Link, and the sensor can be adapted as needed to the application. The sensor can be used in reflex mode operation and as an ultrasonic through-beam sensor.



Ultrasonic Data

Working range, reflex sensor	100...1200 mm
Working range, through-beam sensor	100...2400 mm
Setting Range	100...1200 mm
Reproducibility maximum	2 mm
Linearity Deviation	3 mm
Resolution	1 mm
Ultrasonic Frequency	240 kHz
Service Life (T = +25 °C)	100000 h
Switching Hysteresis	2 % *

Electrical Data

Supply Voltage	18...30 V DC
Current Consumption (U _b = 24 V)	< 40 mA
Switching frequency, reflex sensor	7 Hz
Switching frequency, through-beam sensor	7 Hz
Response time, reflex sensor	71 ms
Response time, through-beam sensor	71 ms
Temperature Drift	< 1 %
Temperature Range	-30...60 °C
Number of Switching Outputs	1
Switching Output Voltage Drop	< 2.5 V
Switching Output/Switching Current	100 mA
Analog Output	0...10 V
Synchronous Mode	Up to 32 sensors
Multiplex Mode	up to 16 sensors
Short Circuit Protection	yes
Reverse Polarity Protection	yes
Overload Protection	yes
Lockable	yes
Interface	IO-Link V1.1 Smart Sensor Profile
Data Storage	yes
Protection Class	III

Mechanical Data

Setting Method	IO-Link
Setting Method	Teach input (for switching output)
Setting Method	Teach-in (for switching output)
Housing Material	Stainless steel, V2A (1.4305 / 303)
Sensing face	Epoxy resin/glass bubble mixture
Sensing face	Plastic, PBT
Sensing face	Silicone
Degree of Protection	IP67
Connection	M12 × 1; 5-pin

Safety-relevant Data

MTTFd (EN ISO 13849-1)	1193,85 a
External Information	A1 preset to window teach-in A1 Switching point close: 157 mm A1 Switching point far: 560 mm A1 Hysteresis: 7 mm Teach button locked + Narrow sound beam

PNP NO/NC switchable	●
Analog Output	●
IO-Link	●
Connection Diagram No.	371
Control Panel No.	D12

* Referring to the switching distance, at least 2 mm.

Complementary Products

Baffle Plate Z0021, Z0022
IO-Link Master
Software

Ctrl. Panel

D12



01 = Switching Status Indicator
 06 = Teach Button
 79 = Run/Error Indicator

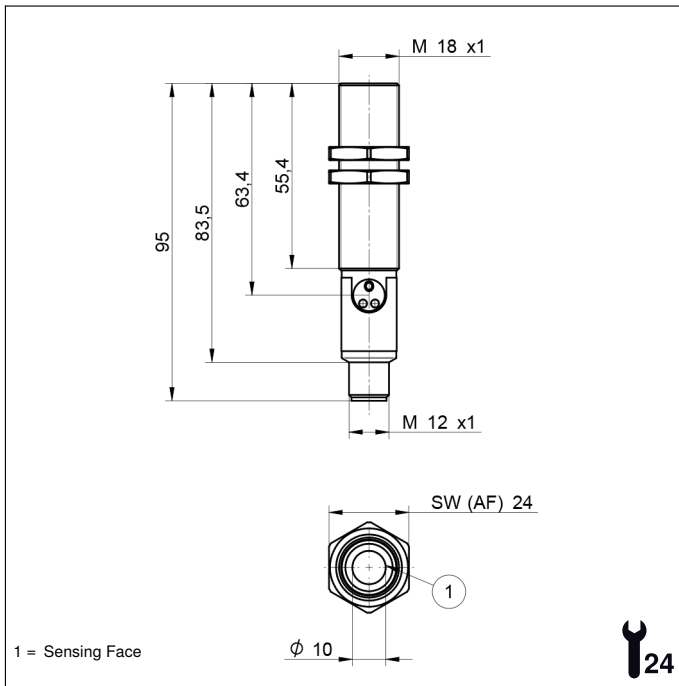

1 = Sensing Face

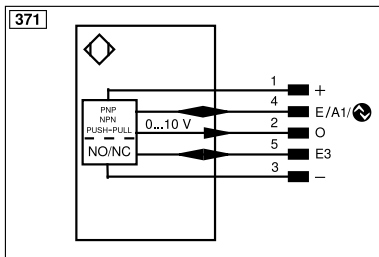

Characteristic response curve

Characteristic curves show the position of the center of the measured object (100 × 100 mm plate) at the time of switching.

U18T Long-Range

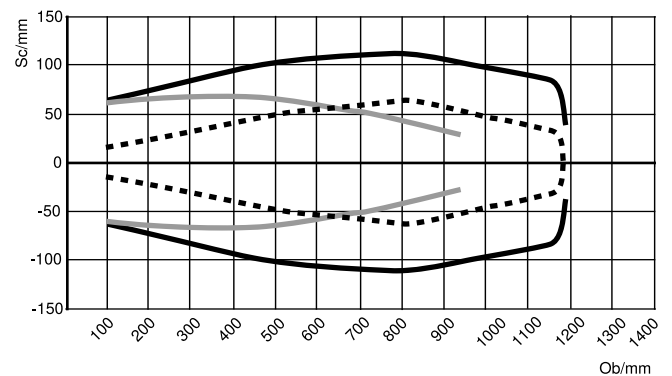

Ob = Object
 Sc = Sonic cone width

- Standard sonic cone (center of the measured object)
- Extra-narrow sonic cone (center of the measured object)
- Standard sonic cone (front edge of the measured object)

