

Operating Instructions

P1PC012

Laser Distance Sensor Triangulation



EN



Table of Contents

1	General	4
1.1	Information Concerning these Instructions	4
1.2	Explanation of Symbols	4
1.3	Limitation of Liability	5
1.4	Copyrights	5
2	For Your Safety	6
2.1	Use for Intended Purpose	6
2.2	Use for Other than the Intended Purpose	6
2.3	Personnel Qualifications	6
2.4	Modification of Products	7
2.5	General Safety Precautions	7
2.6	Laser Warnings	7
2.7	Approvals and protection classes	7
3	Technical Data	8
3.1	General information	8
3.1.1	Light Spot Diameter	9
3.2	Warm-Up Phase	9
3.3	Housing Dimensions	10
3.4	Control panel	10
3.5	Complementary Products	10
3.6	Scope of delivery	11
4	Transport and Storage	12
4.1	Transport	12
4.2	Storage	12
5	Installation and Electrical Connection	13
5.1	Installation	13
5.2	Adjustment	13
5.3	Electrical Connection	15
5.4	Diagnosis	16
5.5	Troubleshooting	16
6	Display	18
7	Settings	19
7.1	Configuration with Push of Button / Teach-In	19
8	Function Description	22
8.1	Sensor Functions	22
8.2	Display Functions	23
8.3	Counter	24
8.4	Input/output functions (I/O)	24
8.4.1	Pin Function	24
8.5	Output Functions	25
8.6	Input Functions	27
8.7	Switching Point Functions (SSC1/SSC2)	27
8.8	Condition Monitoring Functions	30
8.8.1	Status Message Function	30

8.8.2	Warning/Error Output Function	31
8.8.3	Simulation Functions	31
9	NFC	33
10	IO-Link	34
10.1	Parameters.....	34
10.2	Condition Monitoring/Process Data.....	34
10.2.1	Process Data In.....	34
10.2.2	Process Data Out.....	35
10.2.3	Events.....	36
11	wTeach2 Configuration Software.....	37
12	Maintenance Instructions	38
13	Proper Disposal	39
14	Declarations of Conformity.....	40

1 General

1.1 Information Concerning these Instructions

- These instructions make it possible to use the product safely and efficiently.
- These instructions are an integral part of the product and must be kept on hand for the entire duration of its service life.
- Local accident prevention regulations and national work safety regulations must be complied with as well.
- The product is subject to further technical development, and thus the information contained in these operating instructions may also be subject to change. The current version can be found at www.wenglor.com in the product's separate download area.



INFORMATION

The operating instructions must be read carefully before using the product and must be kept on hand for later reference.

1.2 Explanation of Symbols

- Safety precautions and warnings are emphasized by means of symbols and signal words.
- Safe use of the product is only possible if these safety precautions and warnings are adhered to.

The safety precautions and warnings are laid out in accordance with the following principle:

SIGNAL WORD

Type and source of danger!

Possible consequences in the event that the hazard is disregarded.

→ Measures for averting the hazard.

The meanings of the signal words, as well as the scope of the associated hazards, are listed below:



DANGER

This signal word indicates a hazard with a high degree of risk which, if not avoided, results in death or severe injury.



WARNING

This signal word indicates a hazard with a medium degree of risk which, if not avoided, may result in death or severe injury.



CAUTION

This signal word indicates a hazard with a low degree of risk which, if not avoided, may result in minor or moderate injury.



NOTICE

This signal word draws attention to a potentially hazardous situation which, if not avoided, may result in property damage.



INFORMATION

Information draws attention to useful tips and suggestions, as well as information on efficient, error-free use.

1.3 Limitation of Liability

- The product has been developed in consideration of the current state-of-the-art technology, as well as applicable standards and guidelines. Subject to change without notice.
- A valid declaration of conformity can be accessed at www.wenglor.com in the product's separate download area.
- wenglor sensoric elektronische Geräte GmbH (hereinafter referred to as "wenglor") excludes all liability in the event of:
 - Non-compliance with the instructions
 - Use of the product for purposes other than those intended.
 - Use by untrained personnel.
 - Use of unapproved spare parts.
 - Unapproved modification of products.
- These operating instructions do not include any guarantees from wenglor with regard to the described procedures or specific product characteristics.
- wenglor assumes no liability for printing errors or other inaccuracies contained in these operating instructions unless wenglor was verifiably aware of such errors at the point in time at which the operating instructions were prepared.

1.4 Copyrights

- The contents of these instructions are protected by copyright law.
- All rights are reserved by wenglor.
- Commercial reproduction or any other commercial use of the provided content and information, in particular graphics and images, is not permitted without previous written consent from wenglor.

2 For Your Safety

2.1 Use for Intended Purpose

Laser Distance Sensors Triangulation

Triangulation laser distance sensors work according to the principle of angle measurement, where the object's color, shape, and surface do not affect the measurement. Depending on the setting, they can be operated at very high speed or resolution. The measuring range can be selected individually within the sensor's working range.

This Product Can Be Used in the Following Industry Sectors:

- Special-purpose mechanical engineering
- Heavy mechanical engineering
- Logistics
- Automotive industry
- Food industry
- Packaging industry
- Pharmaceuticals industry
- Plastics industry
- Woodworking industry
- Consumer goods industry
- Paper industry
- Electronics industry
- Glass industry
- Steel industry
- Aviation industry
- Chemicals industry
- Alternative energies
- Raw materials extraction

2.2 Use for Other than the Intended Purpose

- Not a safety component in accordance with 2006/42/EC (Machinery Directive).
- The product is not suitable for use in potentially explosive atmospheres.
- The product may be used only with accessories supplied or approved by wenglor, or in combination with approved products. A list of approved accessories and combination products can be found at www.wenglor.com on the product detail page.



DANGER

Risk of personal injury or property damage in case of use for other than the intended purpose!

Use for other than the intended purpose may lead to hazardous situations.

→ Observe instructions regarding use for intended purpose.

2.3 Personnel Qualifications

- Suitable technical training is a prerequisite.
- In-house electronics training is required.
- Trained personnel who use the product must have (permanent) access to the operating instructions.



DANGER

Risk of personal injury or property damage in case of incorrect initial start-up and maintenance!

Personal injury and damage to equipment may occur.

→ Adequate training and qualification of personnel

2.4 Modification of Products



DANGER

Risk of personal injury or property damage if the product is modified!

Personal injury and damage to equipment may occur. Noncompliance may result in loss of the CE and/or UKCA mark and voiding of the warranty.

→ Modification of the product is not permitted

2.5 General Safety Precautions



INFORMATION

These instructions are an integral part of the product and must be kept on hand for the entire duration of its service life.

In the event of possible changes, the current version of the operating instructions can be found at www.wenglor.com in the product's separate download area.

Read the operating instructions carefully before using the product.

Protect the sensor against contamination and mechanical influences.

2.6 Laser Warnings



Laser Class 1 (EN 60825-1)

Applicable standards and safety regulations must be observed.

2.7 Approvals and protection classes

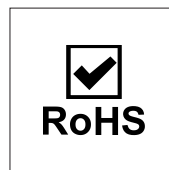
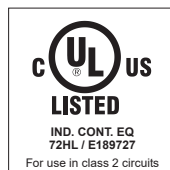
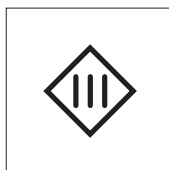

3 Technical Data

3.1 General information

	P1PC012
Optical data	
Working Range	30...80 mm
Reproducibility maximum	30 µm
Reproducibility: 1 Sigma	3 µm
Linearity Deviation	80 µm
Switching Hysteresis	< 0.5 %
Light Source	Laser (red)
Wavelength	655 nm
Service Life (T = +25 °C)	100000 h
Laser Class (EN 60825-1)	1
Max. Ambient Light	10000 Lux
Electrical data	
Supply Voltage	18...30 V DC
Current Consumption (U _b = 24 V)	< 35 mA
Switching Frequency	650 Hz
Measuring Rate	2500 /s
Response Time	< 0.77 ms
Temperature Drift	< 7.5 µm/K
Temperature Range	-25...50 °C
Number of Switching Outputs	1
Switching Output Voltage Drop	< 1.5 V
Switching Output/Switching Current	100 mA
Analog Output	0...10 V
Short Circuit Protection	yes
Reverse Polarity Protection	yes
Overload Protection	yes
Interface	IO-Link V1.1
IO-Link transmission speed	COM3
Protection Class	III
FDA Accession Number	2512215-000
Mechanical data	
Setting Method	Teach-In NFC
Housing Material	Plastic, ABS
Optic Cover	Plastic, PMMA
Degree of Protection	IP67 IP68
Connection	M12 × 1; 5-pin
Safety technology data	
MTTFd (EN ISO 13849-1)	566.57 a
Output functions	
Output	Analog Output PNP
Circuit	NO
Adjustable parameters	

P1PC012	
Output	Error Output Push-pull NPN PNP
Circuit	NC NC/NO NO
Other parameters	Exposure time Laser light Switching hysteresis Teach-in mode Off-delay On-delay

3.1.1 Light Spot Diameter

Working Distance	30 mm	50 mm	80 mm
Spot Size	0,8 × 2,1 mm	0,5 × 1,7 mm	1,0 × 2,0 mm

3.2 Warm-Up Phase

The warm-up phase typically lasts 15 minutes.

After this time, the sensor delivers the specified values for linearity deviation.



NOTICE

Specifications refer to the measured value without load. For all variants, the specification may vary depending on the load at the output.

3.3 Housing Dimensions

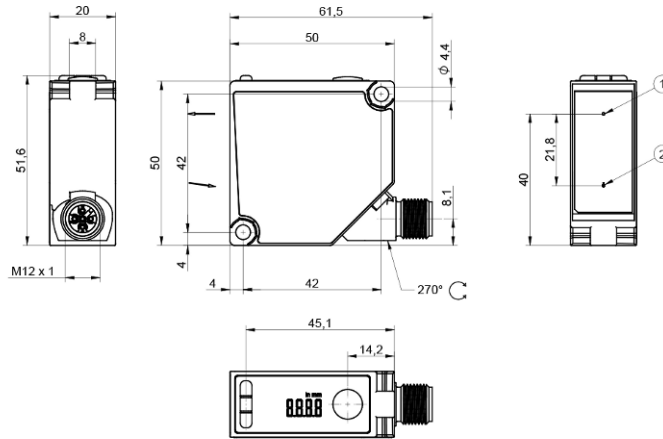

① Transmitter Diode

② Receiver Diode

Screw M4 = 1 Nm

Dimensions in mm (1 mm = 0.03937 inch)

3.4 Control panel

X12

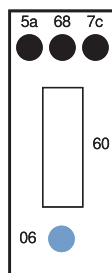

5a = Switching Status Indicator, O1

68 = Power LED

7c = Analog Output Indicator, AO

60 = display

06 = Teach Button

3.5 Complementary Products

wenglor offers you the right connection and mounting technology as well as other accessories for your product. You can find this at www.wenglor.com on the product details page at the bottom.

3.6 Scope of delivery

- Sensor
- Safety precaution
- Z1PE002 spacer sleeves

4 Transport and Storage

4.1 Transport

Upon receipt of shipment, the goods must be inspected for damage in transit. In the case of damage, conditionally accept the package and notify the manufacturer of the damage. Then return the device, making reference to damage in transit.

4.2 Storage

The following points must be taken into consideration with regard to storage:

- Do not store the product outdoors.
- Store the product in a dry, dust-free place.
- Protect the product against mechanical impacts.
- Protect the product against exposure to direct sunlight.



NOTICE

Risk of property damage in case of improper storage!

The product may be damaged.

→ Storage instructions must be complied with.

5 Installation and Electrical Connection

5.1 Installation

- Protect the product from contamination during installation.
- Relevant electrical and mechanical regulations, standards, and safety rules must be observed.
- Protect the product from mechanical impact.
- Ensure that the sensor is mechanically secure.
- Torque values must be observed (see section Technical Data [► 8]).
- Insert the supplied spacer sleeves into the pockets provided on the side facing the mounting surface.
- Mount the sensor using M4 screws through the mounting hole.
- Do not exceed the maximum tightening torque of 0.5 Nm.

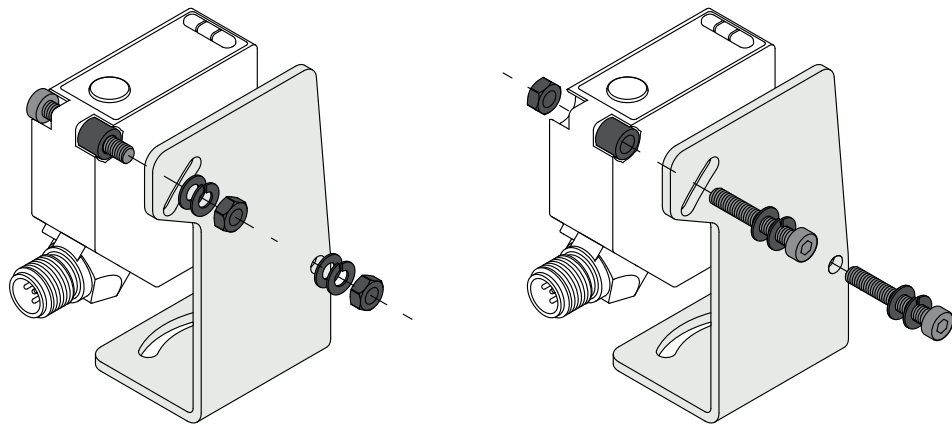

NOTICE

Risk of property damage in case of improper installation!

The product may be damaged!

→ Comply with installation instructions.



CAUTION

Risk of personal injury or property damage during installation!

Personal injury and damage to the product may occur.

→ Ensure a safe installation environment.

5.2 Adjustment

When adjusting sensors, note the following instructions so that the most stable object detection/measurement can be achieved:

Steps/Edges/Depressions

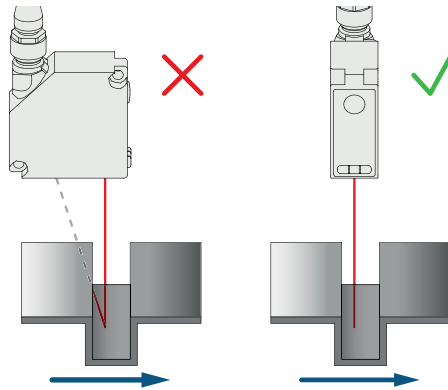

If measuring directly next to steps/edges/depressions, make sure that the receiving beam is not covered by the step/edge. The same applies when measuring the depth of gaps and holes.

With holes, blind holes and edges in the surface of moving parts, the sensor must be positioned so that the edge does not obscure the laser dot.

Round, Glossy surfaces

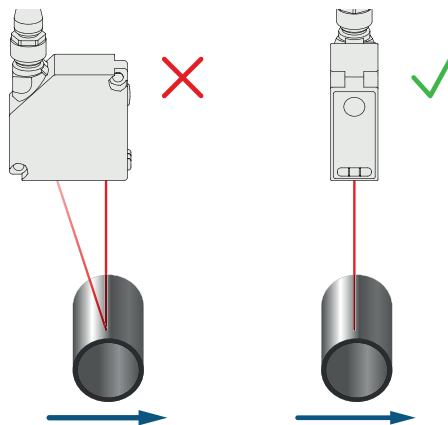

With round, glossy surfaces, the sensor should be positioned on an axis with the round object in order to avoid reflection.

Measuring Objects with Evenly Positioned, Colored Edges

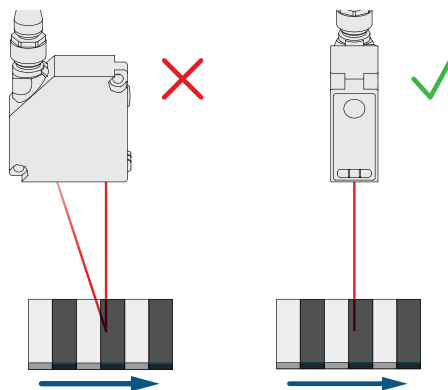

When oriented correctly, the influence on measuring accuracy is minimal. When oriented incorrectly, the different reflectivity of the various colors will result in deviations.

Moving Measuring Objects

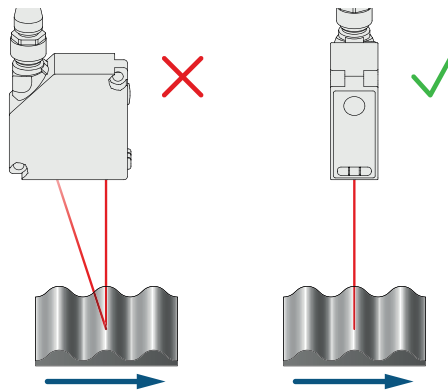

When measuring a moving object, the object must be able to move transversely to the sensor. This prevents shadows and direct reflection to the receiver.

5.3 Electrical Connection

- Wire the sensor according to the connection diagram.
- Switch on the supply voltage (see section Technical Data [► 8]).
- The blue supply voltage indicator lights up.
- Adjust the sensor so that the light spot strikes the object to be detected/measured.



! DANGER

Risk of personal injury or property damage due to electric current.

Live parts may cause damage to persons and equipment.

→ The electrical device may only be connected by qualified personnel.

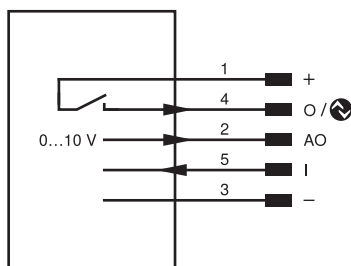

Pin	Pin function	Polarity	Circuit	Signal type
1	Supply voltage +			
2	Analog output			0...10 V
3	Supply voltage 0 V			
4	Switching output	PNP	NO	
5	Input		High active	

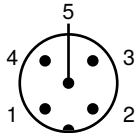

1	Brown	2	White
3	Blue	4	Black
5	Gray		

5.4 Diagnosis

Display	Status	Meaning
Power LED P		Sensor ready
		No voltage supply available
		Warning The LEDs for switching status indicator O1, O2, and analog display AO remain in operation
		Error The LEDs for switching status indicator O1, O2, and analog display AO are not functioning
		Localization Localization function active
Switching status indicator O1, O2		Switching outputs active
		Switching outputs not active
Analog display AO		Object within the set measuring range
		Object outside the set measuring range

- = not lit
 = permanently lit
 = flashing

5.5 Troubleshooting

Error	Possible cause	Remedy
Warning	Signal warning	<ul style="list-style-type: none"> Reduce distance between sensor and object Adjust angle between sensor and object Remove contamination
	Undervoltage	<ul style="list-style-type: none"> Increase voltage supply to at least 18 V DC
	ambient light	<ul style="list-style-type: none"> Adjust sensor alignment to interfering light source
	Temperature too high	<ul style="list-style-type: none"> Mount mounting bracket as cooling plate Reduce load at the outputs
	Temperature too low	<ul style="list-style-type: none"> Increase ambient temperature
Error	Short circuit	<ul style="list-style-type: none"> Check the electrical wiring and eliminate the short circuit
	Temperature error	<ul style="list-style-type: none"> Disconnect the sensor from the supply voltage and allow it to cool Mount the mounting bracket as a heat sink Reduce load on outputs

Error	Possible cause	Remedy
	Device error	<ul style="list-style-type: none"> • Disconnect the sensor from the supply voltage and restart it • Replace the sensor



INFORMATION

Behavior in case of error:

1. Shut down the machine.
2. Analyze and rectify the cause of the error using the diagnostic information.
3. If the error cannot be rectified, contact wenglor support.
4. Do not operate the machine if the error behavior is unclear.
5. The machine must be taken out of service if the error cannot be clearly identified or reliably rectified.



DANGER

Risk of personal injury or property damage if not observed!

The safety function of the system is disabled. Damage to personnel and equipment.

→ Behavior in case of error as specified.

6 Display

This section describes the display and explains the information shown on it.



In the default setting, the currently measured distance is displayed in mm in display mode. The sensor can also be configured via parameters to display the distance in inches. The currently valid unit of measurement is also shown on the display.

If the sensor cannot determine a valid measured value, the following substitute values are shown as status messages on the display:

display	Description
-. -. -. -. .	No signal
NEAR	Object too close
FAR	Object too far away

A detailed explanation of the status messages can be found in the section "[Warning/Error Output Function](#) [▶ 31]."

7 Settings

The sensor can be adjusted via teach-in, IO-Link, wTeach2 and weCon. The different setting options are outlined below.

7.1 Configuration with Push of Button / Teach-In

This section describes the settings that can be configured directly on the sensor using the button.

Switching output

Teach-in

Various teach-in modes are available. These can be set via IO-Link (see section Parameters [▶ 34]). The default setting is foreground teach-in.



Teach-in for O1

1. Adjust the sensor so that the light spot strikes the object to be taught in.
2. Press and hold the teach-in key or enter button for 2 seconds until LED O1 starts flashing.
3. Release the teach-in key or Enter button.
4. The distance is taught in and LED O1 flashes twice briefly to confirm successful teaching.



INFORMATION

When teaching in, if there is no object or the object is too far from the sensor, the switching distance is set to the end of the setting range. The Power LED lights up yellow, and the switching status LEDs for the respective switching output flash twice. The same applies to an object that is too close; here, the switching distance is set to the start of the setting range. If there is an error during teach-in preventing it from being carried out, this is indicated by a red LED.

Readjusting the switching point

The switching point of a digital switching output can be readjusted using a button. There are two options available for this

During the teach-in:

1. Perform teach-in.
2. After successful teach-in, the corresponding LED flashes twice briefly. The taught-in switching point is displayed on the display flashing for 5 seconds. During this time, the switching point can be readjusted.
3. Pressing the teach-in key briefly increases the switching point by one step. After 5 steps, the sensor jumps to a value 5 steps below the taught-in switching point. Pressing the button briefly again increases the switching point. One step corresponds to 0.1 mm.
4. Hold down the teach-in key for 2 seconds until the display changes from a flashing display to a permanent display. The readjusted switching point is accepted. If the teach-in key is not pressed again, the originally taught switching point is accepted after 5 seconds.
5. The switching point has been saved and the LED flashes twice briefly to confirm.

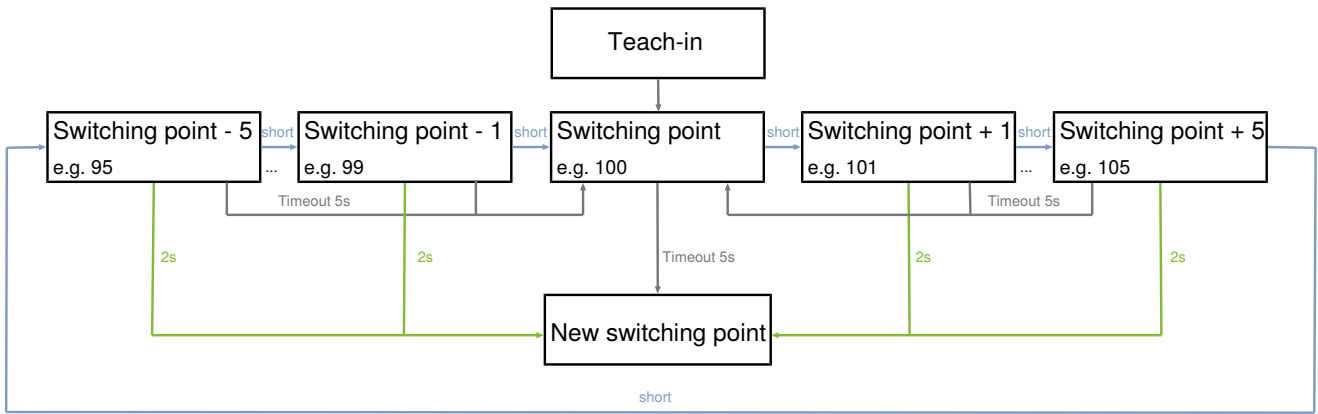

During operation

1. Press and hold the teach-in key for 8 seconds until LEDs A1/A2 start flashing rapidly.
2. Release the teach-in key.
3. LED A1 flashes to indicate that the switching point of A1 can now be readjusted. A short press of the button allows you to switch between A1 and A2 (LED A2 flashes).
4. Press and hold the teach-in key for 2 seconds.
5. The corresponding switching point is shown flashing on the display.
6. Release the teach-in key.
7. You can now continue as described in the illustration above.

analog output

Analog output function

The sensor outputs its measured value as a linearly proportional current or voltage value. The characteristic curve can be set via IO-Link, wTeach2, and NFC within the entire measuring range.

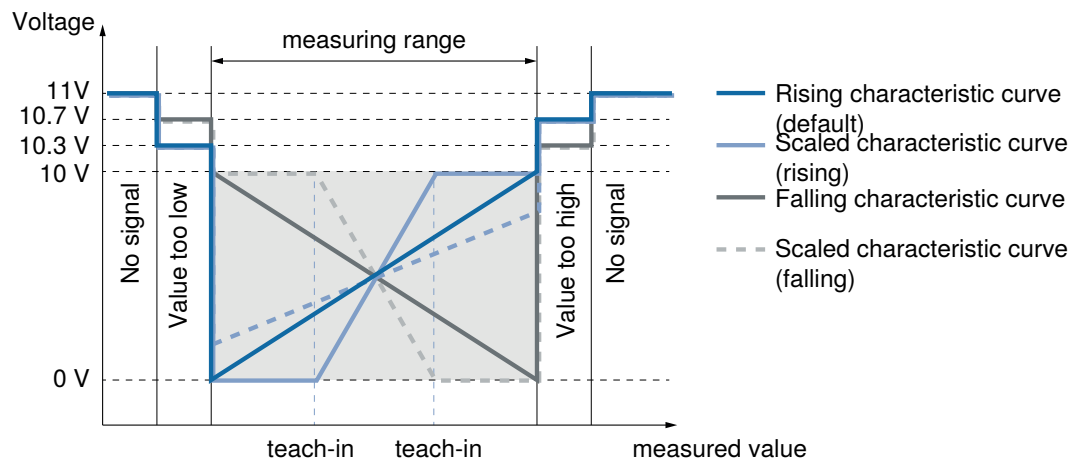

Substitute values

The sensor is able to provide a more accurate diagnosis of whether the analog signal corresponds to a valid measured value within the measuring range using substitute values.

No signal: 11 V

Rising characteristic curve

Object outside the measuring range, close: 10.3 V

Object outside the measuring range, far away: 10.7 V

Falling characteristic curve

Object outside the measuring range close: 10.7 V

Object outside the measuring range, far: 10.3 V

The function of the replacement values can be deactivated via the menu, NFC, or IO-Link.

8 Function Description

The functions described in the following section can be set via wTeach or IODD via IO-Link and additionally via the weCon app via NCF and basic functions via the display menu.

8.1 Sensor Functions

Function	Possible settings	Default
Exposure mode	<p>With black or glossy objects, it may be useful to increase the exposure time. Decreasing the exposure time can be useful if the sensor is aimed at very bright objects. The longer the exposure time, the lower the speed of the sensor.</p> <p>Auto</p> <p>With the Adaptive Autoexposure function, the sensor automatically sets its exposure time or light pulse duration to the object to be detected up to a maximum value.</p> <p>Fix</p> <p>The exposure time is set via the fixed exposure time parameter, i.e., not automatically adjusted by the sensor</p>	Auto
Fixed exposure time	<p>Manual setting of a fixed exposure time</p> <p>1...1600 µs</p>	200 µs
Maximum exposure time	<p>Maximum exposure time in Auto mode.</p> <p>1...1600 µs</p>	200 µs
Measured value filter	<p>A bigger filter improves the sensor's reproducibility and smooths the signal waveform. The higher the filter number, the longer the sensor's response time when the measured values change.</p> <p>0 = OFF</p> <p>1...9</p>	3
Offset	<p>The Offset function is used to change the momentary measured value to a specified value. The switching thresholds and the analog measuring ranges are adapted along with this value. The offset value is added to the current distance.</p>	0 µm
Offset setting	<p>Value to which the current measured value is to be set by a corresponding offset. The offset is calculated automatically.</p> <p>30,000...80,000 µm</p>	0 µm
Apply offset specification	<p>The current measured value is changed to the offset specified value</p> <p>1= apply</p>	0
Distance range	<p>A distance range in which signals are to be evaluated can be defined within the working range. Signals outside the set distance range are ignored and are not included in the signal evaluation. This means that ranges for which no usable signals are expected can be completely hidden.</p> <p>This function can be used to suppress interfering signals, such as those produced by a glass disk, for instance.</p> <p>Min. distance: working range</p> <p>Max. distance: working range</p> <p>Note!</p>	Setting range

Function	Possible settings	Default
	<ul style="list-style-type: none"> Objects outside the set distance range are evaluated as “No signal”. If a distance range is set, a blind spot directly behind this range results. The sensor cannot detect any objects within the blind spot. The size of the blind spot depends on the reflectance of the interfering objects in the hidden area. 	
Emitted light	<p>The sensor’s laser can be switched on or off.</p> <p>On Laser on</p> <p>Off Laser off</p> <p>The sensor no longer supplies a measured value.</p> <p>Note!</p> <ul style="list-style-type: none"> If an input is set as a laser-off input, the emitted light can also be switched on and off via the input. If the laser is switched off, the sensor behavior corresponds to the status “No signal.” 	On
Localization	<p>The sensor’s supply voltage indicator can be set to flash green. This makes it easy to locate the sensor in a system.</p> <p>On The supply voltage for the LED flashes green.</p> <p>Off LEDs in normal operation.</p>	Off
Button lock	<p>Operation via the button can be locked to protect the sensor from unintentional adjustment.</p> <p>Not locked Operation via button possible.</p> <p>Locked Operation via button not possible.</p>	Not locked
Process data format	<p>You can select which content and which format is used for transmitting the process data (see section Process Data [► 34]).</p> <p>Distance in μm</p> <p>Distance in mil</p> <p>Distance in μm + intensity</p> <p>Distance in μm + Counter</p>	Distance in μm
protective housing	<p>When using the protective housing Z1PS006, the protective screen causes an additional measurement error. This error can be compensated by the sensor using this function.</p> <p>Off Compensation for protective housing not active.</p> <p>On Compensation for protective housing active.</p>	Off

8.2 Display Functions

Function	Possible setting	Default
Display content	<p>You can select which content the display should show.</p> <p>Distance</p>	Distance

Function	Possible setting	Default
	<p>The display shows the measured distance in mm/inch.</p> <p>Intensity The display shows the current intensity of the reflected light.</p> <p>Counter The display shows the current counter reading of the counter function.</p>	
Rotate display	<p>Rotate display 180°</p> <p>On</p> <p>Off</p>	Off

8.3 Counter

The counter can be used to count various events in the sensor and respond to them with a switching signal.

Counter	Description	Default
Source	<p>Select which events the counter should use as a source or which processes should be counted.</p> <p>SSC1 Every switching operation of SSC1 is counted.</p> <p>SSC2 Every switching operation from SSC2 is counted.</p> <p>Warning Every switching operation from the warning output is counted.</p> <p>Error Every switching operation from the error output is counted.</p>	SSC1
Threshold	<p>The counter reading at which the counter should trigger a switching operation is defined.</p> <p>If the value is reached, counting is stopped for further events until a reset is performed.</p> <p>1...65535</p>	0
Reset	The counter reading is reset to "0".	

8.4 Input/output functions (I/O)

8.4.1 Pin Function

The pin function is used to define the function of pins I/O1 and I3, as these can be used for different functions.

Pin	Possible settings	Default
I/O1	<p>Switching output The switching point SSC1 is assigned to the switching output.</p> <p>Error output The error output switches when one of the assigned errors occurs, see table "Status messages [► 31]."</p> <p>Warning output The warning output switches when one of the assigned warnings occurs, see table "Status messages [► 31]."</p>	error output

Pin	Possible settings	Default
	<p>Laser off input For explanation, see I3.</p> <p>Teach-in input See I3 for explanation.</p> <p>Counter output The counter output switches as soon as the counter has reached the threshold value.</p> <p>Counter reset input See I3 for explanation.</p> <p>Deactivated The pin is deactivated.</p>	
I3	<p>Laser off input The sensor's transmission light is deactivated as long as the input is activated. The sensor then does not deliver a measured value and sets the status to "No signal."</p> <p>teach-in input teach-in The outputs (switching outputs/analog output) can be set using the same procedure as with the teach-in key (see Configuration with Push of Button / Teach-In [► 19]). An activated input corresponds to a pressed teach-in key.</p> <p>Counter reset input As soon as the input is activated, the current counter reading is reset to "0".</p> <p>Lock If the teach-in input is permanently set to 18...30 V DC, the teach-in key is locked and protected against unintentional adjustment as long as the input signal is present.</p> <p>Deactivated The pin is deactivated.</p>	Laser off input

8.5 Output Functions

The output functions are used to set the physical outputs.

Digital outputs

Function	Possible settings	Default
Polarity	<p>PNP</p> <p>NPN</p> <p>push-pull</p>	PNP
Circuit	<p>NO Light switching (normally open) The output is high when the condition has been met, depending on the setting (switching point, warning, error).</p> <p>NC Dark switching The output is low when the condition has been met, depending on the setting (switching point, warning, error).</p>	NO
on-delay	0...10,000 ms	0 ms

Function	Possible settings	Default
off-delay	0...10,000 ms	0 ms

Analog outputs

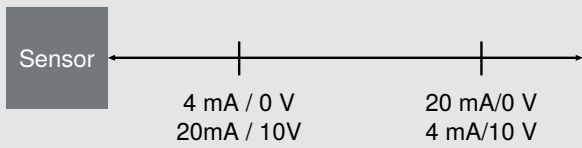
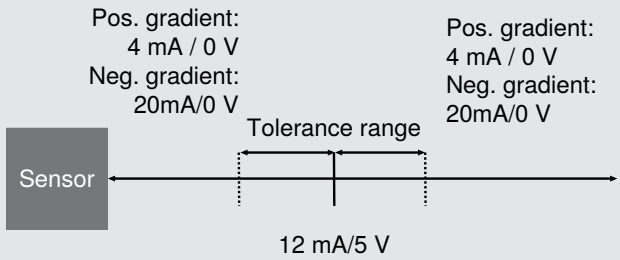
Function	Possible settings	Default
Teach-in	Starts the teach-in process.	
Teach-in mode	<p>Distance</p> <p>A distance is taught in to the analog limit values, and the distance is output as a linearly proportional current or voltage value.</p>  <p>Tolerance</p> <p>A distance is taught in to the measuring range, serving as the measurement reference, for 5 V or 12 mA. The tolerance range is set around this value.</p> 	Distance
0 V	The 0 V value is assigned to a distance within the measuring range. measuring range	30,000 μm
10	The 10 V value is assigned to a distance within the measuring range. measuring range	80,000 μm
5 V	In teach-in mode tolerance In teach-in mode tolerance, the 5 V value is assigned to a distance within the measuring range. measuring range	55,000 μm
Tolerance range	In teach-in mode tolerance The tolerance range is placed symmetrically around the 5 V / 12 mA point and defines the range in which the measurement takes place. 1,000...80,000 μm Note If the tolerance range extends beyond the limits of the measuring range, the corresponding analog values or substitute values for outside the measuring range are output from that point on.	25,000 μm
Tolerance characteristic	In teach-in mode tolerance	Positive slope

Function	Possible settings	Default
	<p>The characteristic specifies whether the analog value increases or decreases with increasing distance.</p> <p>Positive slope The analog value increases with increasing distance</p> <p>Negative slope The analog value decreases as the distance increases</p>	
Analog Replacement values	<p>The replacement values described in the section Settings - analog output can be activated or deactivated.</p> <p>Active Sensor outputs substitute values</p> <p>Deactivated Sensor does not use replacement values</p>	Active

8.6 Input Functions

The input functions are used to set the physical inputs.

Function	Possible settings	Default
Input mode	<p>Supply voltage active Function is triggered as soon as supply voltage is applied to the input.</p> <p>Supply voltage inactive Function is triggered as soon as 0 V is applied to the input or the input is opened.</p>	Supply voltage active

8.7 Switching Point Functions (SSC1/SSC2)

The switching point functions are used to set the two switching points, SSC1 and SSC2.

SSC1 and SSC2 initially only available via IO-Link. If I/O1 is configured as a switching output, it is assigned to SSC1.

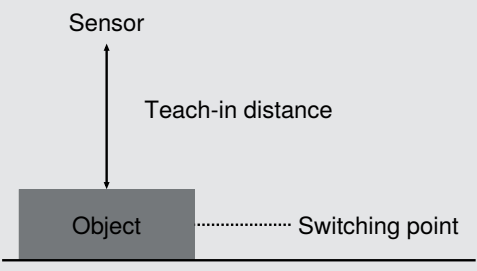
Function	Possible settings	Default
Teach-in	Starts the teach-in process.	
Teach-in mode	<p>Foreground Teach-In</p>  <p>Background Teach-In</p>	Foreground teach-in

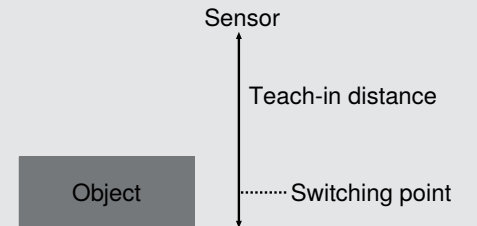
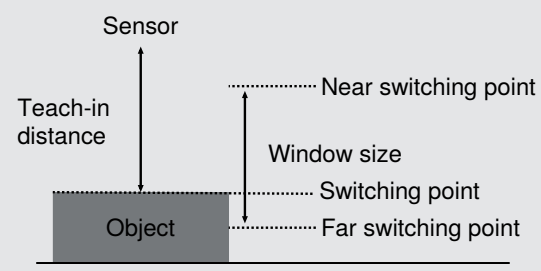
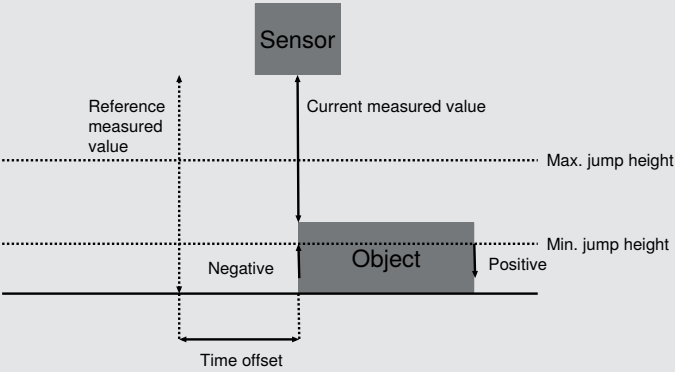
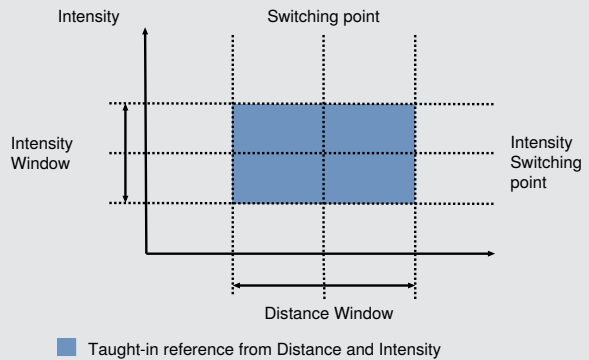
Function	Possible settings	Default
	 <p>Window Teach-In</p>  <p>Jump Detection</p> <p>In this mode, there is no switch to an absolute measured value, but rather to a measured value jump occurring between 2 measurements.</p>  <p>Distance and Intensity</p> <p>In this mode, the intensity of the received signal is also evaluated for distance. The sensor is taught in a reference that consists of a switching point for the distance and a switching point for the intensity. As soon as the sensor detects a deviation in distance or intensity, this is registered via the output.</p>  <p>■ Taught-in reference from Distance and Intensity</p>	

Function	Possible settings	Default
	<p>Note!</p> <p>The teach-in function is necessary to ensure that the sensor works properly.</p>	
Switching point	<p>30,000...80,000 µm</p> <p>Note</p> <p>If a distance range has been set, the switching point can only be set within the set distance range.</p>	80,000 µm
Hysteresis mode	<p>Hysteresis is the difference between the switch-on and switch-off points.</p> <p>Auto</p> <p>The hysteresis is automatically calculated by the sensor in order to optimally adapt it to the respective situation. After a teach-in or change of the switching point, the hysteresis is recalculated and automatically updated in the hysteresis parameter. The information in the data sheet refers to the set switching point, e.g., switching point at 100 mm, hysteresis according to data sheet < 0.5% hysteresis < 0.5 mm</p> <p>Fixed</p> <p>The hysteresis is set to a fixed value in the Hysteresis parameter. This is not automatically adjusted during a teach-in or a change of the switching point. A small hysteresis is recommended for detecting flat objects against a background, while a larger hysteresis is recommended to ensure stable detection under changing conditions.</p>	Auto
hysteresis	<p>Absolute value of the hysteresis in hysteresis mode. Fixed</p> <p>2 µm...50,000 µm</p>	300 µm
Window switching point close	<p>In teach-in mode window teach-in</p> <p>Distance from the set window center to the switching point of the window close to the sensor.</p> <p>The window can be set so that it extends from the minimum setting range to the maximum setting range of the sensor. The minimum and maximum possible settings result from the respective set window center.</p>	30 mm
Window switching point far	<p>In teach-in mode window teach-in</p> <p>Distance from the set window center to the switching point of the window far from the sensor.</p> <p>The window can be set so that it extends from the minimum setting range to the maximum setting range of the sensor. The minimum and maximum possible settings result from the respective window center setting.</p>	30 mm
Jump height min	<p>In teach-in mode Jump detection</p> <p>The minimum jump height defines the jump in the measured value at which a jump event is to be detected.</p> <p>In the "Automatic" setting, the sensor calculates the smallest possible jump independently.</p> <p>0 = Automatic</p> <p>3 µm...50,000 µm</p>	Automatic
Maximum jump height	<p>In teach-in mode, jump detection</p> <p>The max. jump height defines the maximum jump in the measured value at which a jump event is to be detected.</p> <p>In the "No restriction" setting, there is no limit to the max. jump height. A change from a valid measured value to "No measured value" is evaluated as a negative jump.</p> <p>4294967295 = No restriction</p>	No restriction

Function	Possible settings	Default
	3 µm...50,000 µm	
Jump direction	In teach-in mode, jump detection Positive A jump is detected when the measured value jumps to a higher value, i.e. the contrast value becomes brighter. Negative A jump is detected when the measured value jumps to a lower value, i.e. the contrast value becomes darker. Both A jump is detected for both positive and negative.	Negative
Cycle offset	In teach-in mode Jump detection The cycle offset specifies the time-shifted reference measured value with which the current measured value is to be compared in order to detect the jump. 1...256 Cycles	50
Jump pulse duration	In teach-in mode Jump detection 0 = hold The output remains active until the next jump in the opposite jump direction is detected. A combination with the jump direction "Both" is not permitted here. 1...10,000 ms When a jump is detected, the output is activated with the corresponding pulse length.	0
Distance Window	In teach-in mode Distance + Intensity Distance from the set switching point (center of the window) to the boundaries of the window. The distance window is symmetrical around the switching point. 2 µm...10,000 µm	300 µm
Switching point Intensity	In teach-in mode Distance + intensity Switching point of intensity in digits 1...9999	5000
Intensity window	In teach-in mode, distance + intensity from the set switching point intensity (center of the window) to the limits of the window. The intensity window is symmetrical around the switching point. 1...50%	4

8.8 Condition Monitoring Functions

8.8.1 Status Message Function

The sensor provides various status messages. Due to the process data structure, four status messages can be transmitted as individual process data.

These parameters can be used to set the status messages that are transmitted via the process data.

Function	Possible settings	Default
Message 1	See table "Status Messages" [► 31]	Warning signal

Function	Possible settings	Default
Message 2	See table "Status Messages" [▶ 31]	Ambient light
Message 3	See table "Status Messages" [▶ 31]	Temperature too high
Message 4	See table "Status Messages" [▶ 31]	Short circuit

8.8.2 Warning/Error Output Function

The status messages used to trigger the collective message can be defined for the warning output and the error output respectively. The status messages are OR-linked so that the output is activated when one of the defined status messages is activated.

Function	Possible settings	Default
Warning output	See table "Status Messages"	Signal warning, optics dirty, ambient light, temperature too high, temperature too low, undervoltage, interference in the working range
Error output	See table "Status Messages"	Object too close, object too far, no signal, device error, over-temperature, short circuit

Status Messages

Warning	
Undervoltage	The supply voltage is too low.
Warning signal	The object reflects too little light.
Ambient light	Object detection is impeded by ambient light.
Overexposure	The sensor signal is overexposed.
Temperature too high	The sensor's internal temperature is high.
Temperature too low	The sensor's internal temperature is low.
Emitted light off	The sensor's emitted light is switched off.

Error	
Short circuit	A short circuit has occurred on at least one pin.
No signal	The sensor is not receiving a signal.
Object too close	The object is below the setting range or the set measuring range.
Object too far	The object is above the setting range or the set measuring range.
Temperature error	Temperature is outside permissible range. To protect the emitting unit, the emitted light is switched off.
Device error	A hardware error has occurred. For safety reasons, the emitted light is switched off.
Laser error	There is an error in the laser module. For safety reasons, the laser is switched off.

8.8.3 Simulation Functions

This function simulates the behavior of the sensor regardless of its current status and measured value. This allows you to check whether a system in which the sensor is integrated responds correctly to the data supplied by the sensor and processes it accordingly.

If a measured value is specified, the sensor behaves as if the specified measured value corresponds to the actual measured value. This means that the behavior of the outputs and status messages is simulated according to the specified measured value.

In addition, the individual outputs and status messages can be simulated separately from the measured value.

Function	Possible settings	Default
Simulation mode	On Off	Off
Test measured value	Current measured value min...max. measuring range	Current measured value
Test output AO	According to measured value 0...10 V	According to measured value
SSC1 Test	According to the measured value On Off	According to measured value
SSC2 Test	According to the measured value On Off	According to measured value
Status messages test	Tests the individual status messages according to the measured value On Off	According to measured value



INFORMATION

The O1 output is used for IO-Link communication in this function and cannot be simulated.
Simulation mode is automatically terminated as soon as the voltage supply is interrupted.

9

NFC

The devices can be set up and their parameters can be configured via the NFC interface with the aid of a smartphone and the wenglor “weCon” app. Process data cannot be read out via NFC but are available via IO-Link.

You can download the wenglor app free of charge from the Google Play Store or the App Store. Download the app and follow the installation instructions.

Scan the code below to go directly to the wenglor app.



The settings are defined via the app and are then transmitted to the sensor. With the “Read” or “Write” mode activated, hold the smartphone’s antenna just above the sensor’s active NFC sensing surface.



INFORMATION

NFC antenna position

The position of the NFC antenna varies from smartphone to smartphone.

The exact position of the antenna can be found in the operating instructions

If a connection isn’t established immediately, move the smartphone across the active surface until connection is successful,

The sensor does not necessarily have to be connected to the supply voltage for data transmission; that is to say, transmission is also possible in a de-energized state. The only exception is the “Reset” function. This requires a connection to the supply voltage.

10 IO-Link

The sensors can exchange parameters and process data via IO-Link. The parameters can be used to make many additional settings on the device. The process data transmit cyclical data and condition monitoring.

To this end, the sensor is connected to a suitable IO-Link master (see product detail page/complementary products). The interface protocol and the IODD can be found at www.wenglor.com in the download area for the respective product.

10.1 Parameters

The parameters that can be configured via IO-Link are given in the functional description in the section Function description [▶ 22].

10.2 Condition Monitoring/Process Data

The data described in the following section can be read or written cyclically via IO-Link/process data.

10.2.1 Process Data In

The sensor provides certain data that can be output via the process data. Depending on which data is relevant for the application, the "Process data format" parameter can be used to select which data is transferred.

Process data format 1

Data	Meaning
Measured value	Measured distance in micrometers or mil. As the sensor cannot determine a measured value in the following error cases, substitute values are read out: No signal: 0x7FFFFFFC / 2147483644 Object too close: 0x80000008 / -2147483640 Object too far: 0x7FFFFFF8 / 2147483640
Scale	Scaling of the measured value to the base length unit; -6 corresponds to μm .
SSC1	Switching point 1
SSC2	Switching point 2
Warning	Collective warning in the event of one of the warning status messages (see table "Status messages") in the error output function)
Error	Collective warning in the event of one of the error status messages (see table "Status messages") in error output function.
Message 1	Status message 1 read out see Status Message Function [▶ 30]
Message 2	Status message 2 read out see Status Message Function [▶ 30]
Message 3	Status message 3 read out see Status Message Function [▶ 30]
Message 4	Status message 4 read out see Status Message Function [▶ 30]

Process data format 2

Data	Meaning
measured value	Measured distance in micrometers or mils. Since the sensor cannot determine a measured value in the following error cases, substitute values are output: No signal: 0x7FFFFFFC / 2147483644 Object too close: 0x80000008 / -2147483640 Object too far away: 0x7FFFFFF8 / 2147483640

Data	Meaning
Intensity	Intensity of reflected light
SSC1	Switching point 1
SSC2	Switching point 2
Warning	Collective warning in the event of one of the warning status messages (see table "Status messages") in the error output function)
Error	Collective warning in the event of one of the error status messages (see table "Status messages") in error output function.
Message 1	Status message 1 read out see Status Message Function [▶ 30]
Message 2	Status message 2 read out see Status Message Function [▶ 30]
Message 3	Status message 3 read out see Status Message Function [▶ 30]
Message 4	Status message 4 read out see Status Message Function [▶ 30]

Process data format 3

Data	Meaning
measured value	Measured distance in micrometers or mils. Since the sensor cannot determine a measured value in the following error cases, substitute values are output: No signal: 0x7FFFFFFC / 2147483644 Object too close: 0x80000008 / -2147483640 Object too far away: 0x7FFFFFF8 / 2147483640
Counter	Current counter reading of the Counter
SSC1	Switching point 1
SSC2	Switching point 2
Warning	Collective warning in the event of one of the warning status messages (see table "Status messages") in the error output function)
Error	Collective warning in the event of one of the error status messages (see table "Status messages") in error output function.
Message 1	Status message 1 read out see Status Message Function [▶ 30]
Message 2	Status message 2 read out see Status Message Function [▶ 30]
Message 3	Status message 3 read out see Status Message Function [▶ 30]
Message 4	Status message 4 read out see Status Message Function [▶ 30]



NOTICE

When using process data formats 2 and 3, the IO-Link standard no longer complies with the "Measurement Sensors" smart sensor profile.

10.2.2 Process Data Out

Data	Meaning
Emitted light	Transmit signal on/off
Localization	Sensor flashes for easy sensor location
Teach-in SSC1	Starts the teach-in process for SSC1
Teach-in SSC2	Starts the teach-in process for SSC2
Reset counter	The counter reading is reset to "0".

10.2.3 Events

Events are diagnostic information that is standardized by IO-Link and exchanged between the IO-Link master and the device. The following events are supported:

Name	Event code	Type	Specification
Maintenance necessary: Clean	0x8C40	Notification	IO-Link
Device error – unknown error	0x1000	Error	IO-Link
Short circuit – check installation	0x7710	Error	IO-Link
Device temperature too high: Remove heat source	0x4210	Warning	IO-Link
Device temperature too low: Isolate device	0x4220	Warning	IO-Link
Temperature error: Overload	0x4000	Error	IO-Link
Supply voltage too low – check tolerances	0x5111	Warning	IO-Link

11 wTeach2 Configuration Software

For information on installing and connecting the wTeach2 software and its structure, as well as information on the general functions, see the wTeach2 operating instructions. They can be found online in the download area at www.wenglor.com under order number DNNF005.

The wTeach2 operating software can be used to configure all functions, in accordance with the function description [► 22], and read out the IO-Link process data.

12 Maintenance Instructions



NOTICE

This wenglor product is maintenance-free.

Cleaning and inspection of the plug connections at regular intervals are advisable.

Do not clean the product with solvents or cleaning agents that could damage the product.

The product must be protected against contamination during initial start-up.

13 Proper Disposal

wenglor sensoric GmbH does not accept the return of unusable or irreparable products. Respectively valid national waste disposal regulations apply to product disposal.

14 **Declarations of Conformity**

Declarations of conformity can be found on our website at www.wenglor.com in the product's separate download area.