

Bar Light Single Connector

Infrared, 500 mm

LBSI501

Part Number



- Create patented curve effect to reduce LED hot spots
- Flexibility: expand the beam angle with an Angle Changer
- No external control required
- OverDrive

wenglor bar lights from the LBS series are suitable for both small and large working distances. The direct lights can create lighting effects like bright field, low angle of incidence, dark field and dome lighting. Some line scanning applications are also possible. The LBS bar lights can be operated in continuous mode with high intensity or synchronized with the machine vision camera in strobe mode with increased luminosity (OverDrive). In combination with the ZBAG angle changers, the beam angle can be enlarged and designed flexibly.

Technical Data

Optical Data	
Light Source	Infrared Light
Wavelength	850 nm
Risk Group (EN 62471)	1
Beam angle	± 7 °
Infrared light output	486 W/m ²
Measuring point distance	200 mm
Compatible with	Angle Changer
Environmental conditions	
Temperature Range	0...40 °C
Storage temperature	-20...60 °C
Atmospheric humidity	< 80%, non-condensing
Electrical Data	
Supply Voltage	21,6...26,4 V DC
Power	48 W
Peak power	192 W
Current Consumption Continuous Mode (U _b = 24 V)	2 A
Current consumption flash mode OverDrive (operating voltage = 24 V)	8 A
Flash duration (max.)	30 ms
Duty cycle (max.)	< 0,2
Rise time	5 μs
Fall time	25 μs
Input signal	PNP/NPN
Short Circuit Protection	yes
Reverse Polarity Protection	yes
Overload Protection	yes
Protection Class	III
Dimming	0...10 V ± 100...30%
OverDrive	yes
Mechanical Data	
Luminous Field Length (L)	500 mm
Luminous Field Width (W)	31,5 mm
Luminous Field	500 × 31,5 mm
Housing Material	Aluminum, anodised
Housing Material	Plastic, ABS
Housing Material	Plastic, PC
Degree of Protection	IP65
UL Enclosure Type	1
Optic Cover	Plastic, PMMA
Connection	M12 × 1; 5-pin
Max. cable length	< 30 m
Function	
Operating modes	Continuous, Strobe
Connection Diagram No.	007
Control Panel No.	T17
Suitable Mounting Technology No.	925

Complementary Products

ZBAG angle changer
ZBAZ001 bar clamp
ZC4G003 connection cable
ZDCG004 connection cable
ZDCG005 connection cable

Ctrl. Panel

T17

68 = Power LED
 9b = Strobe Mode Indicator

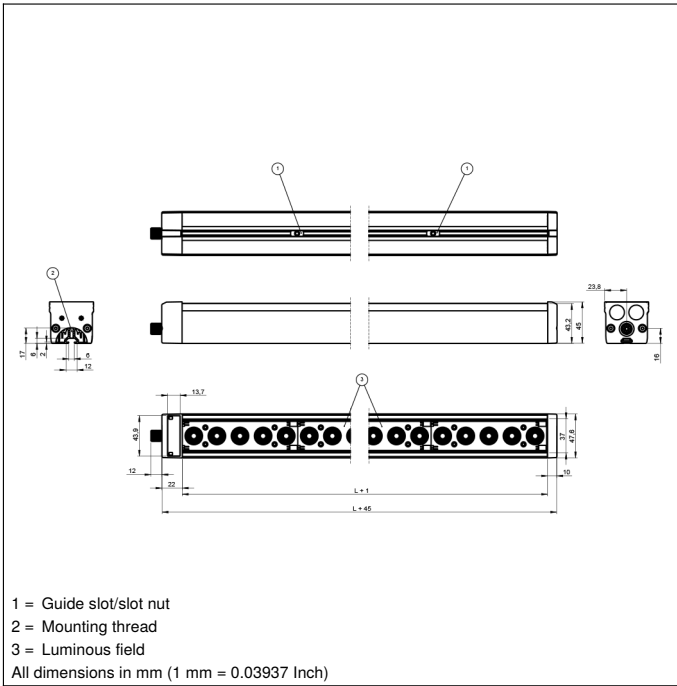

Legend					
+	Supply Voltage +	PT	Platinum measuring resistor	ENAR5422	Encoder A/Ā (TTL)
-	Supply Voltage 0 V	nc	Not connected	ENBR5422	Encoder B/B̄ (TTL)
~	Supply Voltage (AC Voltage)	U	Test Input	ENa	Encoder A
A	Switching Output (NO)	Ū	Test Input inverted	ENb	Encoder B
Ā	Switching Output (NC)	W	Trigger Input	AMIN	Digital output MIN
V	Contamination/Error Output (NO)	W-	Ground for the Trigger Input	AMAX	Digital output MAX
Ū	Contamination/Error Output (NC)	O	Analog Output	Aok	Digital output OK
E	Input (analog or digital)	O-	Ground for the Analog Output	SY In	Synchronization In
T	Teach Input	BZ	Block Discharge	SY OUT	Synchronization OUT
R	Reset input	Amv	Valve Output	Out	Brightness output
Z	Time Delay (activation)	a	Valve Control Output +	M	Maintenance
S	Shielding	b	Valve Control Output 0 V	rsv	Reserved
RxD	Interface Receive Path	SY	Synchronization	Wire Colors according to DIN IEC 60757	
TxD	Interface Send Path	SY-	Ground for the Synchronization	BK	Black
RDY	Ready	E+	Receiver-Line	BN	Brown
GND	Ground	S+	Emitter-Line	RD	Red
CL	Clock	⊕	Grounding	OG	Orange
E/A	Output/Input programmable	SnR	Switching Distance Reduction	YE	Yellow
	IO-Link	Rx+/-	Ethernet Receive Path	GN	Green
PoE	Power over Ethernet	Tx+/-	Ethernet Send Path	BU	Blue
IN	Safety Input	Bus	Interfaces-Bus A(+)/B(-)	VT	Violet
OSSD	Safety Output	La	Emitted Light disengageable	GY	Grey
Signal	Signal Output	Mag	Magnet activation	WH	White
Bl_D+/-	Ethernet Gigabit bidirect. data line (A-D)	RES	Input confirmation	PK	Pink
ENo RS422	Encoder 0-pulse 0/0 (TTL)	EDM	Contacting Monitoring	GNYE	Green/Yellow