

Operating Instructions

P1XD105

Fiber-optic amplifier



EN



Table of Contents

1	General	4
1.1	Information Concerning these Instructions	4
1.2	Explanation of Symbols	4
1.3	Limitation of Liability	5
1.4	Copyrights	5
2	For Your Safety	6
2.1	Use for Intended Purpose	6
2.2	Use for Other than the Intended Purpose	6
2.3	Personnel Qualifications	6
2.4	Modification of Products	7
2.5	General Safety Precautions	7
2.6	Approvals and protection classes	7
3	Technical Data	8
3.1	General data	8
3.2	Housing Dimensions	9
3.3	Control panel	10
3.4	Complementary Products	10
3.5	Scope of delivery	10
4	Transport and Storage	11
4.1	Transport	11
4.2	Storage	11
5	Installation and Electrical Connection	12
5.1	Installation	12
5.1.1	Mounting on a DIN Rail	12
5.1.2	Removal	13
5.1.3	Side Mounting (Using Optional Accessories)	13
5.1.4	Connecting Plastic Fiber-Optic Cables	14
5.2	Electrical Connection	15
5.3	Diagnosis	16
5.4	Troubleshooting	17
6	Settings	18
6.1	Configuration with Push of Button / Teach-In	18
6.1.1	switching output	18
6.1.2	analog output	18
6.1.3	Output Functions	19
6.1.4	Activation of Alignment Tool	19
7	Function Description	20
7.1	Sensor Functions	20
7.2	Display Functions	21
7.3	Input/Output Functions (E/A)	21
7.3.1	Pin Functions	21
7.3.2	Output Functions	21
7.3.3	Input Functions	22
7.4	Switching Point Functions (SSC1/SSC2)	22
7.5	Condition Monitoring/Process Data	25
7.5.1	Status Message Function	25
7.5.2	Warning/Error Output Function	25

7.5.3	Simulation Functions	26
7.5.4	Events.....	26
8	IO-Link	27
9	NFC	28
10	wTeach2 Configuration Software.....	29
11	Maintenance Instructions	30
12	Proper Disposal	31
13	Declarations of Conformity.....	32

1 General

1.1 Information Concerning these Instructions

- These instructions make it possible to use the product safely and efficiently.
- These instructions are an integral part of the product and must be kept on hand for the entire duration of its service life.
- Local accident prevention regulations and national work safety regulations must be complied with as well.
- The product is subject to further technical development, and thus the information contained in these operating instructions may also be subject to change. The current version can be found at www.wenglor.com in the product's separate download area.



INFORMATION

The operating instructions must be read carefully before using the product and must be kept on hand for later reference.

1.2 Explanation of Symbols

- Safety precautions and warnings are emphasized by means of symbols and signal words.
- Safe use of the product is only possible if these safety precautions and warnings are adhered to.

The safety precautions and warnings are laid out in accordance with the following principle:

SIGNAL WORD

Type and source of danger!

Possible consequences in the event that the hazard is disregarded.

→ Measures for averting the hazard.

The meanings of the signal words, as well as the scope of the associated hazards, are listed below:



DANGER

This signal word indicates a hazard with a high degree of risk which, if not avoided, results in death or severe injury.



WARNING

This signal word indicates a hazard with a medium degree of risk which, if not avoided, may result in death or severe injury.



CAUTION

This signal word indicates a hazard with a low degree of risk which, if not avoided, may result in minor or moderate injury.



NOTICE

This signal word draws attention to a potentially hazardous situation which, if not avoided, may result in property damage.



INFORMATION

Information draws attention to useful tips and suggestions, as well as information on efficient, error-free use.

1.3 Limitation of Liability

- The product has been developed in consideration of the current state-of-the-art technology, as well as applicable standards and guidelines. Subject to change without notice.
- A valid declaration of conformity can be accessed at www.wenglor.com in the product's separate download area.
- wenglor sensoric elektronische Geräte GmbH (hereinafter referred to as "wenglor") excludes all liability in the event of:
 - Non-compliance with the instructions
 - Use of the product for purposes other than those intended.
 - Use by untrained personnel.
 - Use of unapproved spare parts.
 - Unapproved modification of products.
- These operating instructions do not include any guarantees from wenglor with regard to the described procedures or specific product characteristics.
- wenglor assumes no liability for printing errors or other inaccuracies contained in these operating instructions unless wenglor was verifiably aware of such errors at the point in time at which the operating instructions were prepared.

1.4 Copyrights

- The contents of these instructions are protected by copyright law.
- All rights are reserved by wenglor.
- Commercial reproduction or any other commercial use of the provided content and information, in particular graphics and images, is not permitted without previous written consent from wenglor.

2 For Your Safety

2.1 Use for Intended Purpose

Fiber-Optic Amplifiers

Plastic fiber-optic cables or glass fiber-optic cables can be connected to fiber-optic amplifiers. Universal reflex sensors can be used both with and without fiber-optic cables. Fiber-optic amplifiers evaluate light reflected from the object. The output switches when an object reaches the set detection range (reflex mode operation) or the active light beam is interrupted (through-beam mode). Bright objects reflect more light than dark objects, and can thus be recognized from greater distances. The color of the object has no influence on working range in barrier mode operation.

This Product Can Be Used in the Following Industry Sectors:

- Special-purpose mechanical engineering
- Heavy mechanical engineering
- Logistics
- Automotive industry
- Food industry
- Packaging industry
- Pharmaceuticals industry
- Plastics industry
- Woodworking industry
- Consumer goods industry
- Paper industry
- Electronics industry
- Glass industry
- Steel industry
- Aviation industry
- Chemicals industry
- Alternative energies
- Raw materials extraction

2.2 Use for Other than the Intended Purpose

- Not a safety component in accordance with 2006/42/EC (Machinery Directive).
- The product is not suitable for use in potentially explosive atmospheres.
- The product may be used only with accessories supplied or approved by wenglor, or in combination with approved products. A list of approved accessories and combination products can be found at www.wenglor.com on the product detail page.



DANGER

Risk of personal injury or property damage in case of use for other than the intended purpose!

Use for other than the intended purpose may lead to hazardous situations.

- Observe instructions regarding use for intended purpose.

2.3 Personnel Qualifications

- Suitable technical training is a prerequisite.
- In-house electronics training is required.
- Trained personnel who use the product must have (permanent) access to the operating instructions.



DANGER

Risk of personal injury or property damage in case of incorrect initial start-up and maintenance!

Personal injury and damage to equipment may occur.

→ Adequate training and qualification of personnel

2.4 Modification of Products



DANGER

Risk of personal injury or property damage if the product is modified!

Personal injury and damage to equipment may occur. Noncompliance may result in loss of the CE and/or UKCA mark and voiding of the warranty.

→ Modification of the product is not permitted

2.5 General Safety Precautions



INFORMATION

These instructions are an integral part of the product and must be kept on hand for the entire duration of its service life.

In the event of possible changes, the current version of the operating instructions can be found at www.wenglor.com in the product's separate download area.

Read the operating instructions carefully before using the product.

Protect the sensor against contamination and mechanical influences.

2.6 Approvals and protection classes

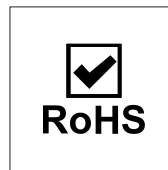
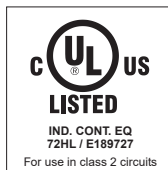
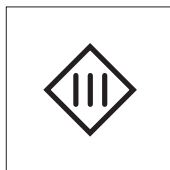

3 Technical Data

3.1 General data

	P1XD105
Optical data	
Switching Hysteresis	< 15 %
Light Source	Red Light
Wavelength	633 nm
Service Life (T = +25 °C)	> 100000 h
Max. Ambient Light	10000 Lux
Electrical data	
Supply Voltage	18...30 V DC
Supply Voltage with IO-Link	18...30 V DC
Current Consumption (U _b = 24 V)	< 40 mA
Digital switching frequency	5 kHz
Analog switching frequency	2 kHz
Digital response time	71 µs
Analog response time	240 µs
On-/Off-Delay	0...10000 ms
Temperature Drift	< 10 %
Temperature Range	-25...60 °C
Switching Output Voltage Drop	< 2 V
Switching Output/Switching Current	100 mA
Analog output	4...20 mA
Short Circuit Protection	yes
Reverse Polarity Protection	yes
Overload Protection	yes
Teach Mode	NT, MT, MT with dynamic readjustment, jump detection, DT, BT, WT
Interface	IO-Link V1.1.3
IO-Link transmission speed	COM3
Protection Class	III
Mechanical data	
Setting Method	NFC Display
Housing Material	Plastic, ABS Plastic, PC Plastic, PA
Degree of Protection	IP50
Connection	M8 × 1; 4-pin
DIN-Rail mounting	35 mm
Safety technology data	
MTTFd (EN ISO 13849-1)	640.47 a
Output functions	
Output	Analog Output PNP
Circuit	NO
Adjustable parameters	

P1XD105	
Output	NPN PNP
Circuit	inactive Error output NC NC+NO NO
Other parameters	2 switching points Off-delay On-delay Dynamic readjustment Error indicator Error output Filter Hysteresis Switching point Emitted light Sensor localization Adjustable sensor mode Teach mode

3.2 Housing Dimensions

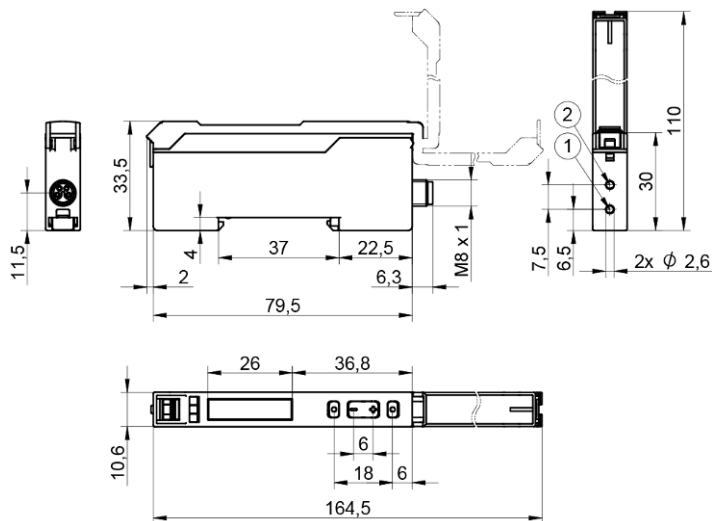

① Transmitter Diode

② Receiver Diode

Dimensions in mm (1 mm = 0.03937 inch)

3.3 Control panel

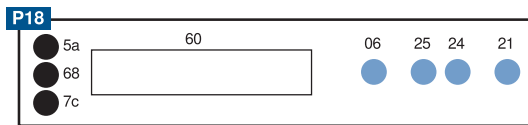

- 06 = Teach Button
- 21 = Mode Button
- 24 = Plus Button
- 25 = Minus Button
- 5a = Switching Status Indicator, A1
- 60 = display
- 68 = Power LED
- 7c = Analog Output Indicator, O

3.4 Complementary Products

wenglor offers you the right connection and mounting technology as well as other accessories for your product. You can find this at www.wenglor.com on the product details page at the bottom.

3.5 Scope of delivery

- Sensor
- Safety precaution

4 Transport and Storage

4.1 Transport

Upon receipt of shipment, the goods must be inspected for damage in transit. In the case of damage, conditionally accept the package and notify the manufacturer of the damage. Then return the device, making reference to damage in transit.

4.2 Storage

The following points must be taken into consideration with regard to storage:

- Do not store the product outdoors.
- Store the product in a dry, dust-free place.
- Protect the product against mechanical impacts.
- Protect the product against exposure to direct sunlight.



NOTICE

Risk of property damage in case of improper storage!

The product may be damaged.

→ Storage instructions must be complied with.

5 Installation and Electrical Connection

5.1 Installation

- Protect the product from contamination during installation.
- Relevant electrical and mechanical regulations, standards, and safety rules must be observed.
- Protect the product from mechanical impact.
- Ensure that the sensor is mechanically secure.
- Torque values must be observed (see section Technical Data [► 8]).



NOTICE

Risk of property damage in case of improper installation!

The product may be damaged!

→ Comply with installation instructions.



CAUTION

Risk of personal injury or property damage during installation!

Personal injury and damage to the product may occur.

→ Ensure a safe installation environment.

5.1.1 Mounting on a DIN Rail

Mounting on a DIN rail is tool-free. Hook the sensor onto the DIN rail and push the sensor down until it clicks into place through the integrated spring.

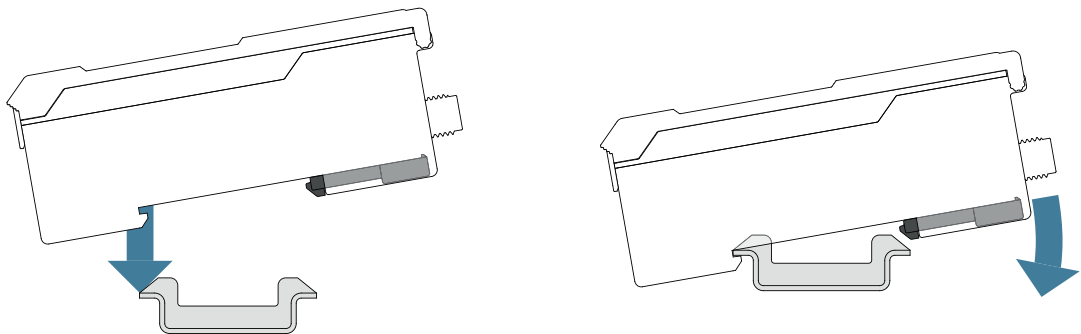

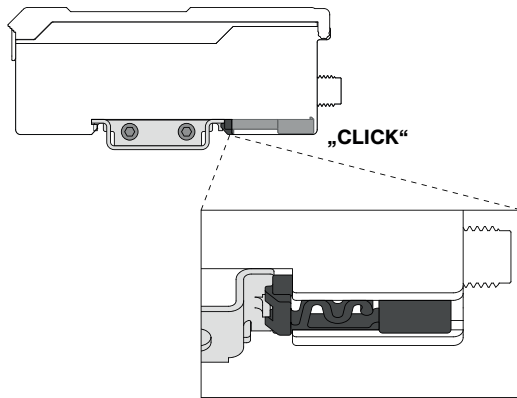

5.1.2 Removal

The sensor can also be removed without tools. Disengage the sensor from the DIN rail by pushing the sensor to the front so that the integrated spring is compressed. This allows you to release the sensor upwards.

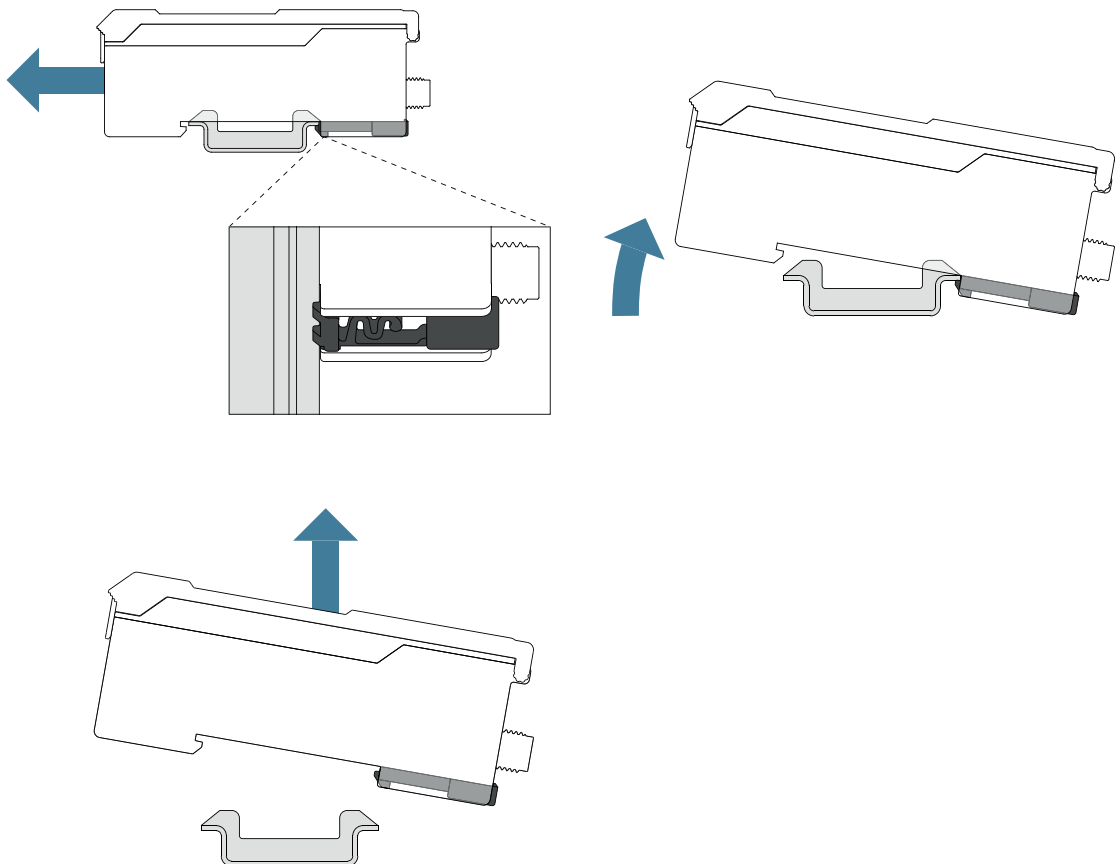

5.1.3 Side Mounting (Using Optional Accessories)

The Z1XZ001 adapter allows the sensor to be mounted on a table or on the side.

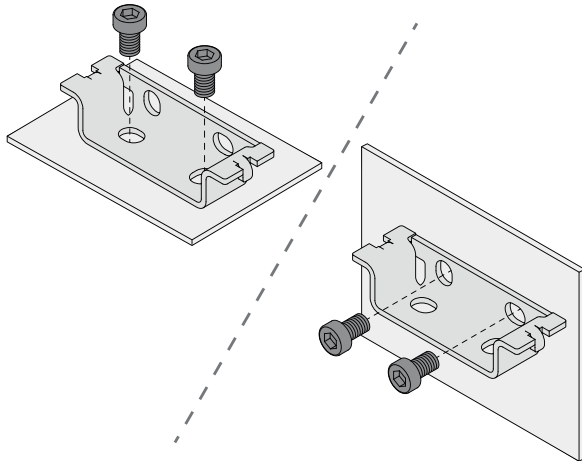

- Fasten the Z1XZ001 adapter with the enclosed mounting set through the mounting holes in the desired position.
- Snap the sensor onto the adapter as described in Mounting on a DIN Rail.

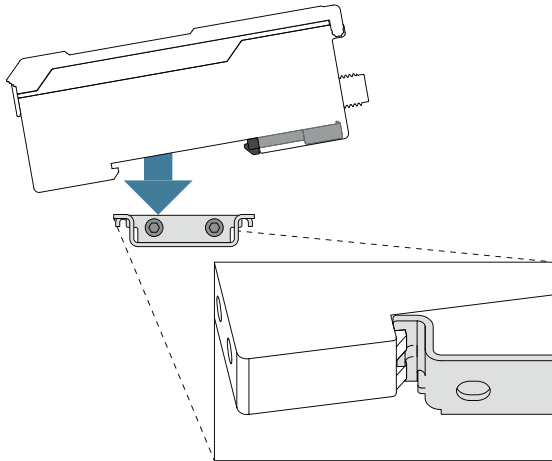

5.1.4 Connecting Plastic Fiber-Optic Cables

- Before first use, shorten the plastic fiber-optic cable once with the SW cutting tool or cut it to the desired length.
- Open the cover and unlock the rocker arm.

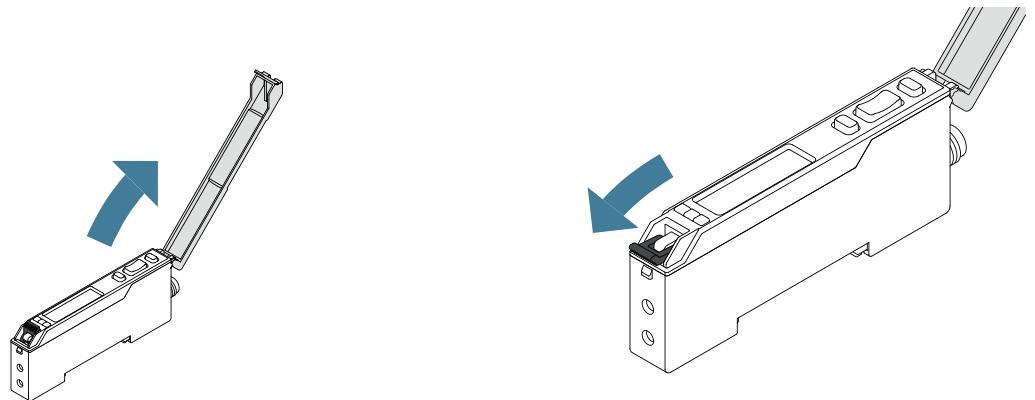

- Insert the fiber-optic cable into the openings provided as far as it will go.

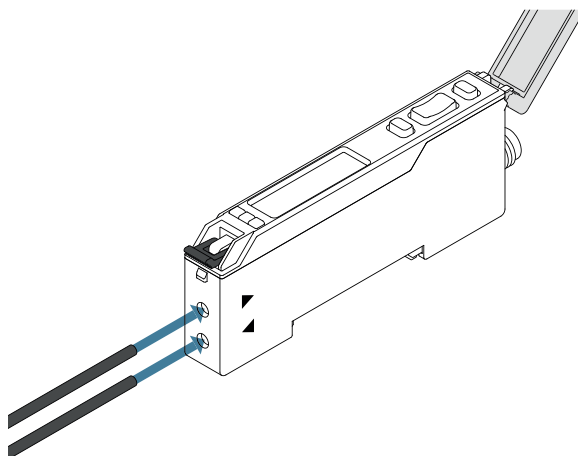

NOTICE

Depending on the fiber-optic cable used, it may be necessary to check how the emitter/receiver is assigned.

- Lock the rocker arm and close the cover.

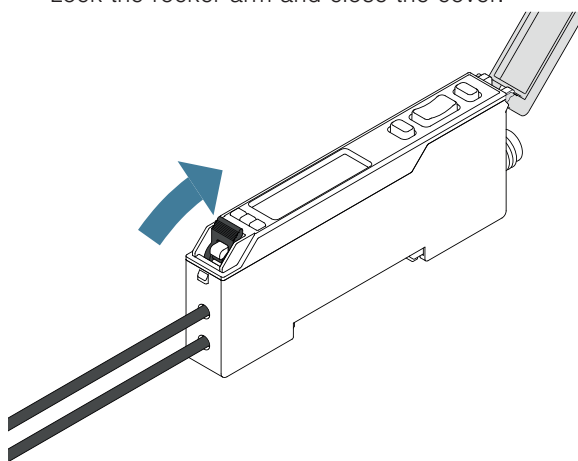

NOTICE

The cover can only be closed when the fiber-optic cable is correctly locked.

5.2 Electrical Connection

- Wire the sensor in accordance with the connection diagram.
- Switch on the supply voltage (see section Technical Data [► 8])
- If using IO-Link, connect the sensor to 18...30 V DC.
- If not using IO-Link, connect the sensor to 10...30 V DC.



DANGER

Risk of personal injury or property damage due to electric current.

Voltage-conducting parts may cause personal injury or damage to equipment.

→ The electric device may be connected by appropriately qualified personnel only.

215

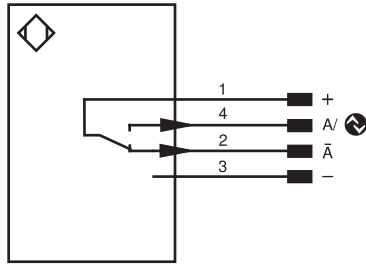

Legend					
+	Supply Voltage +	PT	Platinum measuring resistor	EN _{RS422}	Encoder A/ \bar{A} (TTL)
-	Supply Voltage 0 V	nc	Not connected	EN _{BRS422}	Encoder B/ \bar{B} (TTL)
~	Supply Voltage (AC Voltage)	U	Test Input	ENA	Encoder A
A	Switching Output (NO)	\bar{U}	Test Input inverted	EN _B	Encoder B
\bar{A}	Switching Output (NC)	W	Trigger Input	AMIN	Digital output MIN
V	Contamination/Error Output (NO)	W-	Ground for the Trigger Input	AMAX	Digital output MAX
\bar{V}	Contamination/Error Output (NC)	O	Analog Output	AOK	Digital output OK
E	Input (analog or digital)	O-	Ground for the Analog Output	SY In	Synchronization In
T	Teach Input	BZ	Block Discharge	SY OUT	Synchronization OUT
R	Reset input	AMv	Valve Output	OLT	Brightness output
Z	Time Delay (activation)	a	Valve Control Output +	M	Maintenance
S	Shielding	b	Valve Control Output 0 V	rsv	Reserved
RxD	Interface Receive Path	SY	Synchronization	Wire Colors according to DIN IEC 60757	
TxD	Interface Send Path	SY-	Ground for the Synchronization	BK	Black
RDY	Ready	E+	Receiver-Line	BN	Brown
GND	Ground	S+	Emitter-Line	RD	Red
CL	Clock	\perp	Grounding	OG	Orange
E/A	Output/Input programmable	SnR	Switching Distance Reduction	YE	Yellow
	IO-Link	Rx+/-	Ethernet Receive Path	GN	Green
PoE	Power over Ethernet	Tx+/-	Ethernet Send Path	BU	Blue
IN	Safety Input	Bus	Interfaces-Bus A(+)/B(-)	VT	Violet
OSSD	Safety Output	La	Emitted Light disengageable	GY	Grey
Signal	Signal Output	Mag	Magnet activation	WH	White
BI_D+/-	Ethernet Gigabit bidirect. data line (A-D)	RES	Input confirmation	PK	Pink
EN _{RS422}	Encoder 0-pulse 0/ $\bar{0}$ (TTL)	EDM	Contactors Monitoring	GNYE	Green/Yellow

5.3 Diagnosis

display	Status	Meaning
Power LED		sensor ready
P		No voltage supply available
		Warning The LEDs for switching status indicator A1 and A2 remain in operation
		Error The LEDs for switching status indicator A1 and A2 are not functioning
		Localization Localization function active
Switching status indicator A1		Switching output active
		Switching output not active
Switching status indicator A2		Switching output active
		Switching output not active

- = not lit
- = permanently lit
- = flashing

5.4 Troubleshooting

Error	Possible cause	Remedy
Warning	Signal warning	<ul style="list-style-type: none"> • Reduce distance between sensor and object • Adjust angle between sensor and object • Remove contamination
	Undervoltage	<ul style="list-style-type: none"> • Increase voltage supply to at least 18 V DC
	Temperature too high	<ul style="list-style-type: none"> • Mount mounting bracket as cooling plate • Reduce load on outputs
Error	Short circuit	<ul style="list-style-type: none"> • Check the electrical wiring and eliminate the short circuit
	Temperature error	<ul style="list-style-type: none"> • Disconnect the sensor from the supply voltage and allow it to cool • Mount the mounting bracket as a heat sink • Reduce load on outputs
	Device error	<ul style="list-style-type: none"> • Disconnect the sensor from the supply voltage and restart it • Replace the sensor



INFORMATION

Behavior in case of error:

1. Shut down the machine.
2. Analyze and rectify the cause of the error using the diagnostic information.
3. If the error cannot be rectified, contact wenglor support.
4. Do not operate the machine if the error behavior is unclear.
5. The machine must be taken out of service if the error cannot be clearly identified or reliably rectified.



DANGER

Risk of personal injury or property damage if not observed!

The safety function of the system is disabled. Damage to personnel and equipment.

→ Behavior in case of error as specified.

6 Settings

6.1 Configuration with Push of Button / Teach-In

This section describes the settings that can be configured directly on the sensor using the button.

Control panel and display

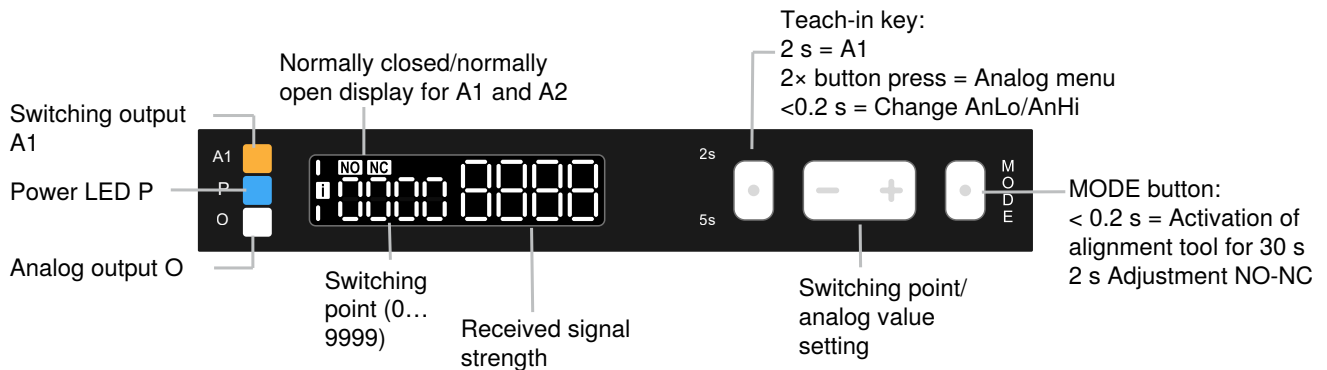

6.1.1 switching output

teach-in

Various teach-in modes are available. These can be set via IO-Link (see section Parameters). The default setting is normal teach-in.

teach-in for A1

1. Adjust the sensor so that the light spot hits the object to be taught in.
2. Press and hold the teach-in key for 2 seconds until LED A1 starts flashing.
3. Release the teach-in key.
4. The switching point is taught in and LED A1 flashes twice briefly to confirm successful teaching.

6.1.2 analog output

teach-in for analog output O

1. Adjust the sensor so that the light spot hits the object to be taught in.
2. To access the analog menu, press the teach-in key twice.
3. The scaled values for the analog output are now displayed. Press the teach-in key again to switch between the AnLo and AnHi settings.

AnLo 1200 AnLo corresponds to 4 mA or 0V

AnHi 8750 AnHi corresponds to 20 mA or 10 V

1. Hold down the teach-in key for 2 seconds or 5 seconds to scale AnLo or AnHi until LED O starts flashing.
2. Release the teach-in key.
3. The analog output is scaled and LED O flashes twice briefly to confirm successful scaling.

The analog output can be scaled manually by pressing the plus or minus button. The set analog value is applied after 30 seconds.

6.1.3 Output Functions

Various output functions are available. The output function NC/NO can be set on the sensor. Further output functions can be set via IO-Link or NFC (see section Parameters).







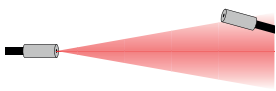

Set NC/NO

1. Select the desired switching output.
2. Press and hold the Mode button for 2 seconds until the NO/NC indicator starts to flash.
3. Pressing the Mode button again briefly changes the display from NO to NC or vice versa.
4. After 5 seconds, the selected setting is applied to the selected switching output.

6.1.4 Activation of Alignment Tool

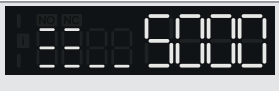
1. Pressing the Mode button briefly (< 0.2 s) activates the alignment tool for 30 seconds.
2. The alignment tool has two methods of support:
 - Bar graphs
 - A bar graph is now shown on the display. This together with a digit value shows the current signal strength. The more bars displayed, the better the signal and vice versa.
 - Pulsed light
 - The faster the emitter emits light pulses, the higher the signal strength and vice versa.

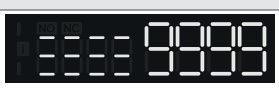
The following table shows the different installation situations of transmitter and receiver fiber-optic cables with the relevant display on the sensor display and the behavior of the emitted light.

Alignment of the fiber-optic cable emitter and receiver	Sensor display	Pulsed light	Description
			Very poor alignment – no signal received
			Moderate alignment – medium signal strength is achieved
			Optimal alignment – full signal strength is achieved



NOTICE

With certain fiber types or if there is a large distance between emitter and receiver, it may not be possible to achieve the maximum signal strength. In this case, the orientation must be selected so that the signal value is as large as possible.

7 Function Description

The functions described in the following section can be set via wTeach or IODD via IO-Link and additionally via the weCon app via NCF and basic functions via the display menu.

7.1 Sensor Functions

Function	Possible settings	Default
Localization	<p>The LED P of the sensor can be switched to flashing green. This allows the sensor to be easily located in a plant.</p> <p>On LED P flashes green.</p> <p>Off LEDs in normal function.</p>	Off
Key disabling	<p>The teach-in key can be locked to protect the sensor against accidental adjustment.</p> <p>Unlocked Operation possible via the teach-in key</p> <p>Locked Operation via teach-in key not possible</p>	Unlocked
teach-in mode	<p>Teach-in modes are available. These are described in more detail in section " Switching Point Functions (SSC1/SSC2) [► 22]".</p>	A1 = NT
Emitted light	<p>The transmit LED of the sensor can be switched on or off.</p> <p>On Transmit LED on</p> <p>Off Transmit LED off The sensor no longer supplies a measured value.</p> <p>Note!</p> <ul style="list-style-type: none"> If the emitted light LED is switched off, the sensor behavior corresponds to the status "No signal." 	On
Luminous intensity of transmitter light	<p>The luminous intensity of the emitter LED can be adjusted.</p> <p>Minimum The luminous intensity is set to a minimum.</p> <p>medium The luminous intensity is set to medium.</p> <p>Maximum The luminous intensity is set to maximum.</p> <p>Custom The luminous intensity can be set within a range of 5 to 100%.</p>	Maximum
Filter	<p>The interference filter can be used to increase measurement reliability in the event of temporary interference. A higher filter level allows the interfering signals to be ignored. If changes happen suddenly, the response time is extended. This extension of the response time depends on the filter level and the mode used. The maximum switching frequency can be reached only with minimum filter selection</p> <p>Minimum Medium</p>	Minimum

Function	Possible settings	Default
	Maximum	
Hysteresis	The hysteresis is the difference between the switch-on and switch-off point and can be set in 3 stages. Minimum Medium Maximum	Minimum
Alignment tool	Can be activated by briefly pressing the mode button for 30 seconds	Deactivated

7.2 Display Functions

Function	Possible setting	Default
Rotate display	Rotate display 180° On Off	Off

7.3 Input/Output Functions (E/A)

7.3.1 Pin Functions

The pin function is used to define the function of the pins, as they can be used for different functions.

Function	Possible settings	Default settings
A1	switching output The switching point SSC1 is assigned to the switching output. error output The error output switches when one of the assigned errors occurs, see table "Status messages." Warning output The warning output switches when one of the assigned warnings occurs, see table "Status messages".	switching output

Different pin functions can be set for the individual inputs/outputs. Depending on the setting as input or output, there are corresponding additional parameterization options that influence the behavior.

7.3.2 Output Functions

The output functions are used to set the physical outputs.

Digital outputs

Function	Possible settings	Default
PNP/NPN/push-pull	PNP The load or analysis module is connected between the negative pole (reference) and the output. When the sensor switches, the output is connected to the positive pole via an electronic switch. The switching signal is maintained when a pull-down resistor is connected. NPN	PNP

Function	Possible settings	Default
	The load or the analysis module is connected between the positive pole (reference) and the output. When the sensor switches, the output is connected to the negative pole via an electronic switch. The switching signal is maintained when a pull-up resistor is connected. push-pull PNP and NPN are switched alternately.	
Normally closed/normally open	NO Light switching (normally open) The output is closed when the condition has been met, depending on the setting (switching point, warning, error). NC Dark switching The output is open when the condition has been met, depending on the setting (switching point, warning, error).	A1: Normally open contact
On-delay	0...10,000 ms	0 ms
Off-delay	0...10,000 ms	0 ms
Impulse	0...10,000 ms	0 ms

Analog outputs

Function	Possible settings	Default setting
4 mA	The 4 mA value is assigned to a signal value within the range. range	0
20 mA	The 20 mA value is assigned to a signal value within the range. range	9999
0	The 0 V value is assigned to a signal value within the range. range	0
10 V	The 10 V value is assigned to a signal value within the range. range	9999

7.3.3 Input Functions

The input functions are used to set the physical inputs.

Function	Possible settings	Default
Input mode	Supply voltage active Function is triggered as soon as supply voltage is applied to the input. Supply voltage inactive Function is triggered as soon as 0 V is applied to the input or the input is opened.	Supply voltage active

7.4 Switching Point Functions (SSC1/SSC2)

The switching point functions are used to set the two switching points, SSC1 and SSC2.

Function	Possible settings	Default
Teach-in	Starts the teach-in process.	
Teach-in mode	Normal Teach-In	NT

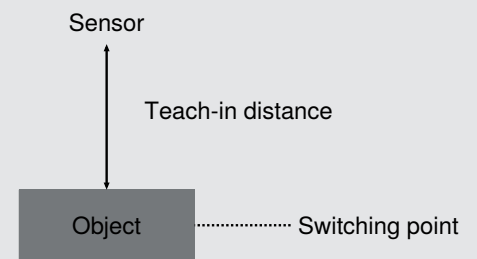
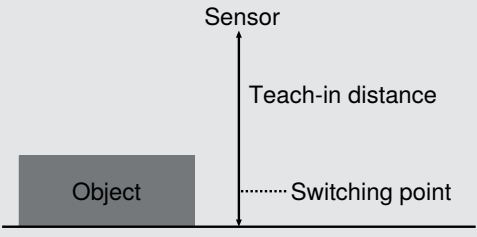
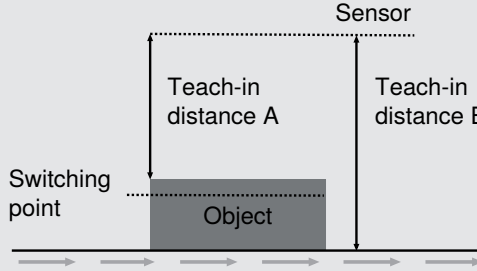
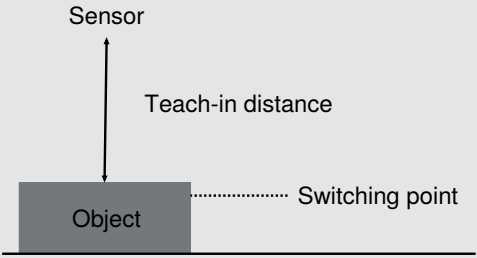
Function	Possible settings	Default
	 <p data-bbox="550 537 790 571">Background Teach-In</p>  <p data-bbox="550 907 758 940">Dynamic Teach-In</p>  <p data-bbox="550 1288 758 1321">Minimum Teach-In</p>  <p data-bbox="550 1657 813 1691">Dynamic Readjustment</p> <p data-bbox="550 1702 1236 1780">Continuous readjustment of the switching threshold of the sensor. The time interval for readjustment can be set on the interface.</p>	

Function	Possible settings	Default
	<p>The graph shows 'Light intensity' on the y-axis and time 't' on the x-axis. A horizontal line represents the 'Switching threshold'. A shaded area above the threshold is labeled 'Teach-in process'. A vertical dip in the signal is labeled 'Commencing contamination'. A note states: 'The switching threshold is readjusted continuously in order that the distance between signal and threshold stays the same.' Below the graph are two diagrams: 'Window Teach-In' showing 'Sensor', 'Object', 'Teach-in distance', 'Near switching point', 'Window size', 'Switching point', and 'Far switching point'; and 'Jump Detection' showing 'Sensor', 'Object', 'Reference measured value', 'Current measured value', 'Max. jump height', 'Min. jump height', 'Negative', 'Positive', and 'Time offset'.</p>	
switching point	The switching point corresponds to the switching threshold of the contrast value and is defined in digits. 0...9999	
Window size High Low	In teach-in mode window The set value High defines the window starting from the taught-in switching point upwards – the value Low downwards. 0...9999	High: 1000 Low: 1000
Jump height min	In teach-in mode Jump detection The minimum jump height defines the jump in the measured value at which a jump event is to be detected. 100...5000	300
Jump direction	In teach-in mode, jump detection Positive A jump is detected when the measured value jumps to a higher value, i.e. the contrast value becomes higher. Negative A jump is detected when the measured value jumps to a lower value, i.e. the contrast value becomes lower.	Positive

Function	Possible settings	Default
	Both A jump is detected for both positive and negative.	
Time offset	For teach-in mode jump detection The time offset specifies the time-shifted reference measured value with which the current measured value is to be compared in order to detect the jump. 0...340 ms	34
Jump pulse duration	In teach-in mode Jump detection 0 = hold The output remains active until the next jump in the opposite direction is detected. When a jump is detected, the output is activated with the corresponding pulse length.	0
Maximum detected jump height	The last highest detected signal jump is shown in digits in order to make it easier to set the jump height. The highest measurement can be reset via IO-Link or weCon app to detect a new maximum.	

7.5 Condition Monitoring/Process Data

The data described in the following section can be read or written cyclically via IO-Link/process data.

7.5.1 Status Message Function

The sensor provides various status messages. Due to the process data structure, four status messages can be transmitted as individual process data.

These parameters can be used to set the status messages that are transmitted via the process data.

7.5.2 Warning/Error Output Function

Status Messages

Warning	
Undervoltage	The supply voltage is too low.
Contaminated optics	The sensor detects when the optic cover is dirty, and the signal deteriorates as a result
Temperature too low	The sensor's internal temperature is low.
Temperature too high	The sensor's internal temperature is high.
Error	
Short circuit	A short circuit has occurred on at least one pin.
Temperature error	Temperature is outside permissible range. To protect the emitting unit, the emitted light is switched off.
Device error	A hardware error has occurred. For safety reasons, the emitted light is switched off.

7.5.3 Simulation Functions

This function simulates the behavior of the sensor regardless of the current status and measured value. This can be used to check whether a plant in which the sensor is integrated reacts correctly to the data supplied by the sensor and processes them accordingly.

If a measured value is specified, the sensor behaves as if the specified measured value corresponds to the actual measured value. This means that the behavior of the outputs and status messages is simulated according to the specified measured value.

In addition, the individual outputs and status messages can be simulated separately from the measured value.



INFORMATION

Output A1 is used for IO-Link communication in this function and cannot be simulated.

Simulation mode ends automatically as soon as the power supply is interrupted.

Function	Possible settings	Default
Simulation mode	On Off	Off
Test signal value	Current signal value 0...9999	Current measured value
SSC1 Test	According to the measured value On Off	According to measured value
SSC2 Test	According to the measured value On Off	According to measured value
Status messages test	Tests the individual status messages according to the measured value On Off	According to measured value

7.5.4 Events

Events are diagnostic information that is standardized by IO-Link and exchanged between the IO-Link master and the device. The following events are supported:

Name	Event Code	Type
Fatal error	100	Error
Short circuit – check installation	101	Error
Supply voltage too low – check tolerance	2	Warning
Supply voltage error	101	Error
Temperature error – Overload	102	Error
Device temperature too high – remove heat source	3	Warning
Device temperature too low – isolate device	3	Warning
Signal warning	1	Warning
Dirty optics – cleaning	1	Warning
Supply voltage too low – check tolerance	101	Error

8 IO-Link

The sensors can exchange parameters and process data via IO-Link. The parameters can be used to make many additional settings on the device. The process data transmit cyclical data and condition monitoring.

To this end, the sensor is connected to a suitable IO-Link master (see product detail page/complementary products). The interface protocol and the IO-Link Data Sheet (IODD) can be found at www.wenglor.com in the download area for the respective product.

9

NFC

The devices can be set up and their parameters can be configured via the NFC interface with the aid of a smartphone and the wenglor “weCon” app. Process data cannot be read out via NFC but are available via IO-Link.

You can download the wenglor app free of charge from the Google Play Store or the App Store. Download the app and follow the installation instructions.

Scan the code below to go directly to the wenglor app.



The settings are defined via the app and are then transmitted to the sensor. With the “Read” or “Write” mode activated, hold the smartphone’s antenna just above the sensor’s active NFC sensing surface.



INFORMATION

NFC antenna position

The position of the NFC antenna varies from smartphone to smartphone.

The exact position of the antenna can be found in the operating instructions

If a connection isn’t established immediately, move the smartphone across the active surface until connection is successful,

The sensor does not necessarily have to be connected to the supply voltage for data transmission; that is to say, transmission is also possible in a de-energized state. The only exception is the “Reset” function. This requires a connection to the supply voltage.

10 wTeach2 Configuration Software

For information on installing and connecting the wTeach2 software and its structure, as well as information on the general functions, see the wTeach2 operating instructions. They can be found online in the download area at www.wenglor.com under order number DNNF005.

The wTeach2 operating software can be used to configure all functions, in accordance with the function description [► 20], and read out the IO-Link process data.

11 Maintenance Instructions



NOTICE

This wenglor product is maintenance-free.

Cleaning and inspection of the plug connections at regular intervals are advisable.

Do not clean the product with solvents or cleaning agents that could damage the product.

The product must be protected against contamination during initial start-up.

12 Proper Disposal

wenglor sensoric GmbH does not accept the return of unusable or irreparable products. Respectively valid national waste disposal regulations apply to product disposal.

13 **Declarations of Conformity**

Declarations of conformity can be found on our website at www.wenglor.com in the product's separate download area.