

# Glass Fiber-Optic Light Curtain

for Fiber-Optic Cable Sensors

## 403-370-104

Part Number



- For measuring tasks
- Resistant to high temperature
- Variable light emitting slot

Glass fiber optic cable curtains function in accordance with the through-beam sensor principle. The fibers are arranged in a single line, thus creating a luminous row. If these fiber optic cable curtains are used in combination with an analog universal diffuse light sensor (UF22MV3, UF55MV3), the length of the slot corresponds to the analog range. If a universal diffuse light sensor with switching output is utilized (UF88PA), the switching point can be adjusted so that the output is switched when the light slot is obstructed to a defined extent.



### Technical Data

#### Optical Data

Fiber Bundle Diameter	4 mm
Linearity	< 10 %
Range with Sensor Type UF55MV3	150...700 mm
Range with Sensor Type UF22MV3	60...300 mm
Range with Sensor Type U_55__	1305 mm
Range with Sensor Type U_66__	1450 mm
Range with Sensor Type U_87__	1450 mm
Range with Sensor Type U_88__	1450 mm
Opening Angle	68 °
Fiber	Step Index
Fiber Diameter	50 μm
Fiber Distribution	statistical mixture

#### Mechanical Data

Temperature Range	-25...180 °C
Bending Radius	70 mm
Fiber-Optic Length	1 m
Jacket Material	CuZn, nickel-plated
Material End Sleeve	Aluminum
End Sleeve No.	70

Fiber-Optic Cable Adapter No.

**001**

403-370-104

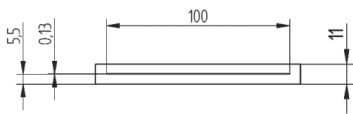
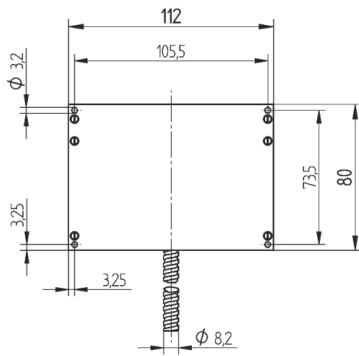

All dimensions in mm (1 mm = 0.03937 Inch)

