

# Laser Distance Sensor Triangulation

## P3PC211S01

Part Number



- Analog output: 4...20 mA
- Graphical display for easy operation
- Measured value independent of material, color and brightness
- Rugged aluminium housing
- Wireless settings via Bluetooth

These laser distance sensors work with a fine red light beam and a high-resolution CMOS line. They determine the distance between the sensor and the object by means of the triangulation principle. Thanks to the integrated TripleA technology, the sensors offer high precision, temperature stability and material independence. This means they deliver accurate results even with objects of different materials, colors and shapes, as well as in fluctuating light and temperature conditions. Settings are entered via the easy-to-read OLED display or via Bluetooth using the weCon app.

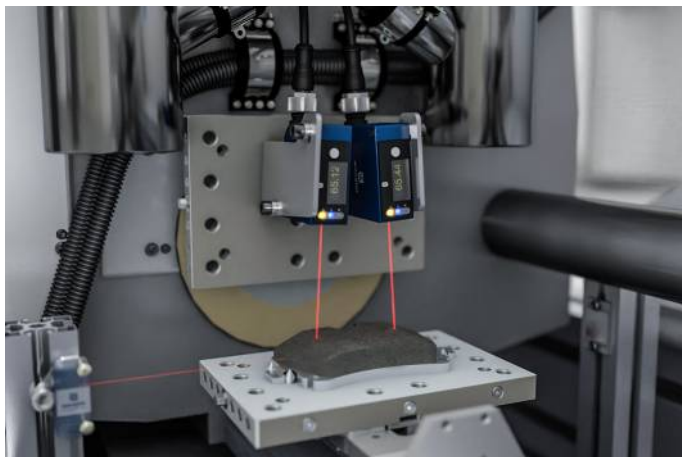

### Technical Data

| Optical Data              |             |
|---------------------------|-------------|
| Working Range             | 50...350 mm |
| Measuring Range           | 50...350 mm |
| Reproducibility maximum   | 100 $\mu$ m |
| Reproducibility: 1 Sigma  | 10 $\mu$ m  |
| Linearity Deviation       | 300 $\mu$ m |
| Light Source              | Laser (red) |
| Wavelength                | 655 nm      |
| Service Life (T = +25 °C) | 100000 h    |
| Laser Class (EN 60825-1)  | 1           |
| Max. Ambient Light        | 20000 Lux   |
| Light Spot Diameter       | see Table 1 |

| Electrical Data                             |                |
|---|----------------|
| Supply Voltage                              | 18...30 V DC   |
| Current Consumption (U <sub>b</sub> = 24 V) | < 60 mA        |
| Measuring Rate                              | 2500 /s        |
| Response Time                               | < 0,5 ms       |
| Temperature Drift                           | < 20 $\mu$ m/K |
| Temperature Range                           | -30...60 °C    |
| Analog Output                               | 4...20 mA      |
| Short Circuit Protection                    | yes            |
| Reverse Polarity Protection                 | yes            |
| Overload Protection                         | yes            |
| Interface                                   | IO-Link V1.1   |
| IO-Link Version                             | 1.1            |
| IO-Link transmission speed                  | COM3           |
| Protection Class                            | III            |
| FDA Accession Number                        | 2310674-000    |

| Mechanical Data      |                       |
|----------------------|-----------------------|
| Setting Method       | IO-Link               |
| Housing Material     | Aluminum, anodised    |
| Housing Material     | Plastic, ABS          |
| Degree of Protection | IP67                  |
| Connection           | M12 $\times$ 1; 5-pin |
| Optic Cover          | Plastic, PMMA         |

| Safety-relevant Data   |         |
|------------------------|---------|
| MTTFd (EN ISO 13849-1) | 408,4 a |

|               |   |
|---------------|---|
| Error Output  | ● |
| Analog Output | ● |
| IO-Link       | ● |

|                                   |        |
|-----------------------------------|--------|
| Connection Diagram No.            | 242    |
| Control Panel No.                 | X6     |
| Suitable Connection Equipment No. | 2   35 |
| Suitable Mounting Technology No.  | 380    |

Display brightness may decrease with age. This does not result in any impairment of the sensor function.

### Complementary Products

|                   |  |
|-------------------|--|
| IO-Link Master    |  |
| IO-Link converter |  |
| Protective Screen |  |
| Software          |  |

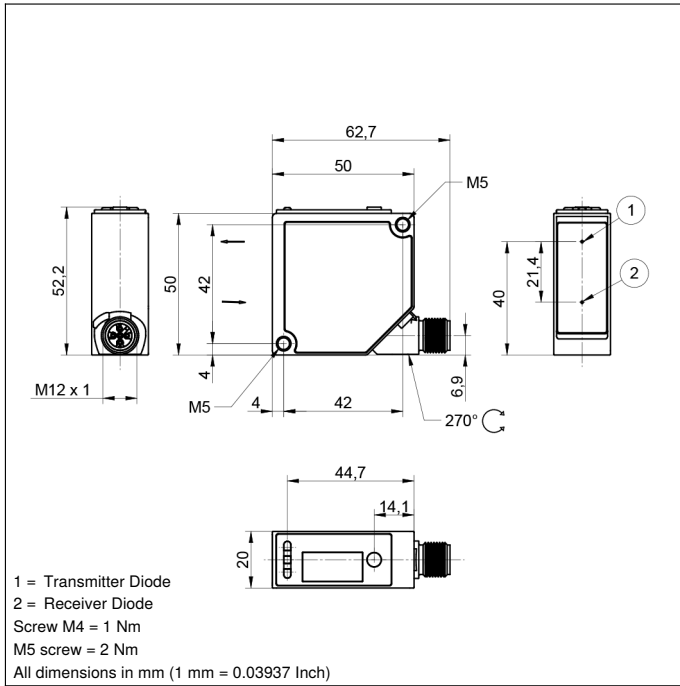

### Ctrl. Panel

X6

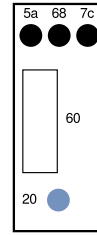

20 = Enter key  
 5a = Switching Status Indicator, A1  
 60 = display  
 68 = Power LED  
 7c = Analog Output Indicator, O

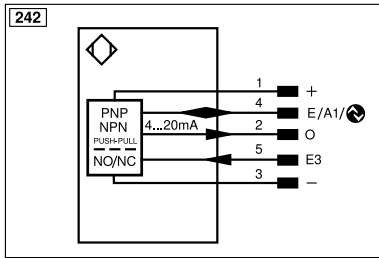

| Legend              |  |                     |                                |  |                     |
|---------------------|--|---------------------|--------------------------------|--|---------------------|
| +                   | Supply Voltage +                           | nc                  | Not connected                  | EN <sub>RS422</sub>                    | Encoder B/B̄ (TTL)  |
| -                   | Supply Voltage 0 V                         | U                   | Test Input                     | ENA                                    | Encoder A           |
| ~                   | Supply Voltage (AC Voltage)                | Ū                   | Test Input inverted            | EN <sub>B</sub>                        | Encoder B           |
| A                   | Switching Output (NO)                      | W                   | Trigger Input                  | AMIN                                   | Digital output MIN  |
| Ā                   | Switching Output (NC)                      | W-                  | Ground for the Trigger Input   | AMAX                                   | Digital output MAX  |
| V                   | Contamination/Error Output (NO)            | O                   | Analog Output                  | AOK                                    | Digital output OK   |
| ȳ                   | Contamination/Error Output (NC)            | O-                  | Ground for the Analog Output   | SY In                                  | Synchronization In  |
| E                   | Input (analog or digital)                  | BZ                  | Block Discharge                | SY OUT                                 | Synchronization OUT |
| T                   | Teach Input                                | Amv                 | Valve Output                   | OLT                                    | Brightness output   |
| Z                   | Time Delay (activation)                    | a                   | Valve Control Output +         | M                                      | Maintenance         |
| S                   | Shielding                                  | b                   | Valve Control Output 0 V       | rsv                                    | Reserved            |
| RxD                 | Interface Receive Path                     | SY                  | Synchronization                | Wire Colors according to DIN IEC 60757 |                     |
| TxD                 | Interface Send Path                        | SY-                 | Ground for the Synchronization | BK                                     | Black               |
| RDY                 | Ready                                      | E+                  | Receiver-Line                  | BN                                     | Brown               |
| GND                 | Ground                                     | S+                  | Emitter-Line                   | RD                                     | Red                 |
| CL                  | Clock                                      | ±                   | Grounding                      | OG                                     | Orange              |
| E/A                 | Output/Input programmable                  | SnR                 | Switching Distance Reduction   | YE                                     | Yellow              |
| IO-Link             |  | Rx+/-               | Ethernet Receive Path          | GN                                     | Green               |
| PoE                 | Power over Ethernet                        | Tx+/-               | Ethernet Send Path             | BU                                     | Blue                |
| IN                  | Safety Input                               | Bus                 | Interfaces-Bus A(+)/B(-)       | VT                                     | Violet              |
| OSSD                | Safety Output                              | La                  | Emitted Light disengageable    | GY                                     | Grey                |
| Signal              | Signal Output                              | Mag                 | Magnet activation              | WH                                     | White               |
| BI_D+/-             | Ethernet Gigabit bidirect. data line (A-D) | RES                 | Input confirmation             | PK                                     | Pink                |
| EN <sub>RS422</sub> | Encoder 0-pulse 0/0̄ (TTL)                 | EDM                 | Contact Monitoring             | GNYE                                   | Green/Yellow        |
| PT                  | Platinum measuring resistor                | EN <sub>RS422</sub> | Encoder A/Ā (TTL)              |  |                     |

Table 1

| Working Distance    | 50 mm  | 200 mm | 350 mm |
|---------------------|--------|--------|--------|
| Light Spot Diameter | 1,5 mm | 1 mm   | 1 mm   |

