

Operating Instructions

S2FP103

Safety Switch with Lock Function

Electromechanic, Power to Unlock Principle



EN



Table of Contents

1	Operating Instructions	3
1.1	Function	3
1.2	Target Group	3
2	Intended use	4
3	Safety precautions	5
3.1	Explanation of Symbols	5
3.2	Safety Precautions	5
3.3	Warning against misuse	6
3.4	Disclaimer	6
3.5	Approvals and protection class	6
4	Technical Data	7
4.1	General data	7
4.2	Safety assessment	9
4.3	Connection diagram	10
4.4	Housing dimensions	10
4.5	Complementary Products	11
4.6	Structure	12
5	Installation	13
5.1	General installation instructions	13
5.2	Actuating directions	13
5.3	Minimum distance	14
5.4	Auxiliary release	15
5.5	Installation with mounting plate	15
6	Initial Start-Up	17
6.1	Electrical connection	17
6.1.1	How the safety outputs work	17
6.1.2	Requirements for downstream evaluation	17
6.1.3	Series connection	17
6.1.4	Connection Example	18
6.2	Magnet control	18
6.3	Actuator coding	18
6.4	Latching force	19
7	Maintenance instructions	20
8	Diagnosis	21
8.1	Diagnostic information	21
8.2	Signal output	21
8.3	Errors	23
8.4	Error warning	23
9	Disassembly	24
10	Proper Disposal	25
11	Declarations of Conformity	26

1 Operating Instructions

1.1 Function

- These operating instructions provide the necessary information for the installation, initial start-up, safe operation, and disassembly of the guard locking device.
- The operating instructions must always be kept in a legible condition and accessible.

1.2 Target Group

- All work described in these operating instructions may only be carried out by trained specialist personnel authorized by the plant operator.
- Only install and commission the device if you have read and understood the operating instructions and are familiar with applicable regulations on work safety and accident prevention.
- The selection and installation of the devices, as well as the integration of their controls, require the machine manufacturer to have qualified knowledge of relevant laws and normative requirements.

2 Intended use

This wenglor product should be used in accordance with the following functional principle:

Guard locking device

The electro-sensitive, electronic guard locking device is designed for use in safety circuits and is used to monitor and lock the position of movable guards.



NOTICE

The guard locking devices are classified as type 4 interlocking devices in accordance with EN ISO 14119. Versions with individual coding are classified as highly coded.



CAUTION

If a safely monitored locking device is required by the risk analysis, a variant with guard locking monitoring (S2FP0xx) must be used. The actuator-monitored variant (S2FP1xx) is a safety switch with lock function for process safety.

The safety function consists of safely switching off the safety outputs when the safety guard is unlocked or opened and keeping the safety outputs safely switched off when the safety guard is open or unlocked.

3 Safety precautions

3.1 Explanation of Symbols

- Safety precautions and warnings are emphasized by means of symbols and signal words.
- Safe use of the product is only possible if these safety precautions and warnings are adhered to.

The safety precautions and warnings are laid out in accordance with the following principle:

SIGNAL WORD

Type and source of danger!

Possible consequences in the event that the hazard is disregarded.

→ Measures for averting the hazard.

The meanings of the signal words, as well as the scope of the associated hazards, are listed below:



DANGER

This signal word indicates a hazard with a high degree of risk which, if not avoided, results in death or severe injury.



WARNING

This signal word indicates a hazard with a medium degree of risk which, if not avoided, may result in death or severe injury.



CAUTION

This signal word indicates a hazard with a low degree of risk which, if not avoided, may result in minor or moderate injury.



NOTICE

This signal word draws attention to a potentially hazardous situation which, if not avoided, may result in property damage.



INFORMATION

Information draws attention to useful tips and suggestions, as well as information on efficient, error-free use.

3.2 Safety Precautions

- These instructions are an integral part of the product and must be kept on hand for the entire duration of its service life.
- Read the operating instructions carefully before using the product.
- Installation, initial start-up and maintenance of the product may only be carried out by qualified personnel.

- Tampering with or modifying the product is impermissible.
- Protect the product from contamination during initial start-up.
- The safety instructions given in the operating instructions must be followed, as must the country-specific installation requirements and regulations on safety and accident prevention.



CAUTION

Failure to observe this warning may result in malfunctions or faults.



WARNING

Failure to observe this warning may result in personal injury and/or damage to the machine.

3.3 Warning against misuse



WARNING

In the event of improper or unintended use or tampering, the use of the safety switch may pose a risk to persons or cause damage to machine or system components.

3.4 Disclaimer

- The products described here have been developed to perform safety-related functions as part of an overall system or machine. It is the responsibility of the manufacturer of a system or machine to ensure that it functions correctly as a whole.
- No liability is accepted for damage or malfunctions resulting from installation errors or failure to observe these operating instructions.
- The manufacturer accepts no further liability for damage resulting from the use of replacement parts or accessories not approved by the manufacturer.
- For safety reasons, any unauthorized repairs, modifications, or alterations are not permitted and exclude any liability on the part of the manufacturer for any resulting damage.

3.5 Approvals and protection class

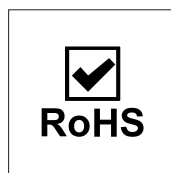
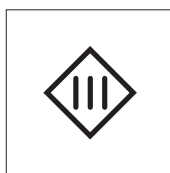

This device is intended to be powered by a Class 2 source. This device shall be powered with the use of a Listed (CYJV) cable/connector assembly rated 24Vdc, 0.8 A minimum.

4 Technical Data

4.1 General data

guard locking device

Technical data	
Electrical data	
supply voltage	20.4...26.4 V DC (stabilized PELV power supply)
No-load current _{I₀}	< 0.1 A
Current consumption Device with magnet switched on	Average: < 0.2 A Peak current: < 0.35 A / 200 ms
Conditional rated short-circuit current	100 A
External line and device fuse protection 2	2 A gG
Response time of safety outputs when switched off by actuator, maximum	100 ms
Response time of the safety outputs when switched off by the safety inputs, maximum	1.5 ms
risk time	≤ 200 ms
Standby delay	≤ 5 s
switching frequency	≤ 0.5 Hz
protection class	III
Rated insulation voltage U _i	32 V DC
Rated impulse withstand voltage U _{imp}	0.8 kV
Overvoltage category	III
Degree of pollution	3
Safety outputs OSSD1/OSSD2	
safety output	Semiconductor, PNP output, short-circuit proof
Number of safety outputs	2
Use category	DC-12: U _e /I _e : 24 V DC / 250 mA DC-13: U _e /I _e : 24 V DC / 250 mA
Rated operating current I _e	250 mA
Residual current I _r	≤ 0.5 mA
voltage drop	≤ 2 V
Test pulse duration	≤ 0.5 ms
Test pulse interval	1000 ms
ZVEI classification	ZVEI CB24I
Source	C2
Sink	C1, C2
Cross-circuit monitoring via sensor	Yes
Safety inputs IN1/IN2	
Number of safety inputs	2
Voltage range	-3...5 V (low) 15...30 V (high)
Current consumption per input	≤ 5 mA / 24 V
Accepted test pulse duration on input signal	≤ 1.0 ms
With a test pulse interval of	≥ 100 ms
ZVEI classification	ZVEI CB24I

Technical data	
Source	C1, C2, C3
Sink	C1
Signal output (not safety-related)	
signal output	Semiconductor, PNP output, short-circuit proof
Use category	DC-12: Ue/Ie: 24 V DC / 50 mA DC-13: Ue/Ie: 24 V DC / 50 mA
Rated operating current Ie	50 mA
Voltage drop	≤ 2 V
Solenoid control Mag	
Voltage range	-3...5 V (low) 15...30 V (high)
current consumption	10 mA / 24 V
Duty cycle magnet	100
Accepted test pulse duration on input signal	≤ 5.0 ms
With a test pulse interval of	≥ 40 ms
ZVEI classification	ZVEI CB24I
Source	C1, C2, C3
Sink	C0
Mechanical data	
locking force F _{max}	1500 N
locking force F _{Zh}	1150 N
latching force	25 N / 50 N
Mechanical service life	≥ 1,000,000 switching cycles (for door masses ≤ 5 kg, operating speed ≤ 0.5 m/s)
Service life when used as door stop	≥ 50,000 switching cycles (for door masses ≤ 5 kg, operating speed ≤ 0.5 m/s)
Angular offset between locking device and actuator	≤ 2°
connection type	M12×1, 8-pin
Mounting screws	2 × M6
Tightening torque for mounting screws	6...7
housing material	Plastic, glass fiber reinforced, thermoplastic
vibration resistance	10...150 Hz Amplitude 0.35 mm
shock resistance	30 g / 11 ms
switching distance	2 mm
Protected switching distance S _{ao}	1 mm
Protected switching-off distance S _{ar}	20 mm
ambient conditions	
temperature range	0...60 °C
Storage and transport temperature	-10...90 °C
Relative humidity, maximum	93% (non-condensing, non-icing)
degree of protection	IP66/IP67/IP69 (EN 60529)
Altitude / installation height above sea level	max. 3000 m
Safety technology data	
Functional safety key figures	See section on safety considerations [► 9]
PDDb (EN 60947-5-3)	Yes
Function	
power to unlock principle	Yes

operating principle	RFID
Frequency band	125 kHz
Transmission power	max. – 6 dBm
coding	Individually teachable
Coding level (EN ISO 14119)	High
series connection	Yes Number of sensors Unlimited, observe external line protection Length of sensor chain max. 200 m
Detent	Yes
Auxiliary release	Yes
Actuator monitoring	Yes
Other data	
Suitable actuator	S2FP200

actuator

Technical	
Electrical data	
temperature range	0...60 °C
Storage and transport temperature	-10...90 °C
Mechanical data	
housing material	Plastic, glass fiber reinforced, thermoplastic
degree of protection	IP66/IP67/IP69 (EN 60529)

4.2 Safety assessment

Interlock function

performance level (EN ISO 13849-1)	Up to PL e
Safety category (EN ISO 13849-1)	Cat. 4
Safety integrity level (EN 61508)	Suitable for applications in SIL 3
PFH value	5.20×10^{-10} /h
PFD value	4.50×10^{-5}
Mission time _{TM} (EN ISO 13849-1)	20 years



CAUTION

1. If the normally closed version of a guard locking device cannot be used in an application, a locking device with the power to lock principle can be used in this exceptional case if additional safety measures are implemented that provide an equivalent level of safety.
2. The customer must implement additional measures, such as safe control and safe cable routing, to prevent faults.
3. If a fault occurs that results in the interlock function being unlocked, this is detected by the guard locking device and the safety outputs switch off. The occurrence of such a fault could cause the protective device to open immediately and once before the safe state of the machine is reached. The system behavior of category 2 allows a fault to occur between tests, resulting in the loss of the safety function, and the loss of the safety function is detected by the test.
4. The control of the locking device must be compared externally with the OSSD enable signal. If a shutdown occurs here due to unintentional unlocking, this is detected by the external diagnostics.

4.3 Connection diagram

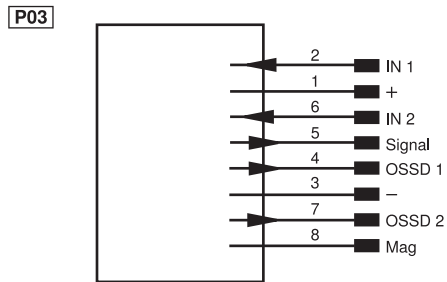

IN	Safety input
+	Supply voltage +
-	Supply voltage 0 V
Signal	signal output
OSSD	safety output
Mag	Magnetic control

4.4 Housing dimensions

guard locking device

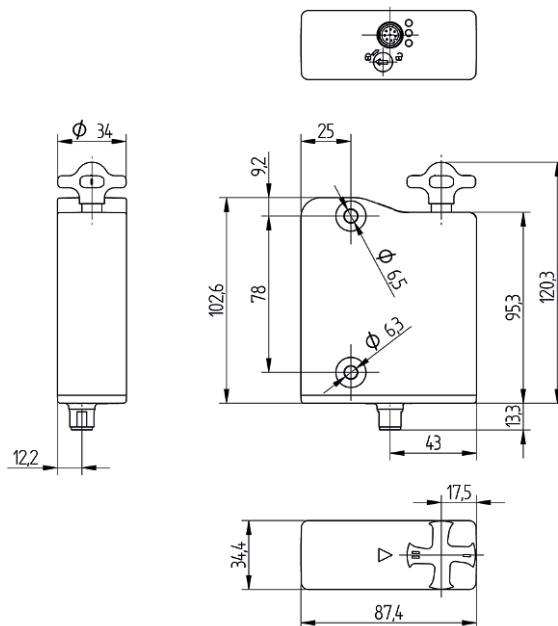

Actuator S2FP200

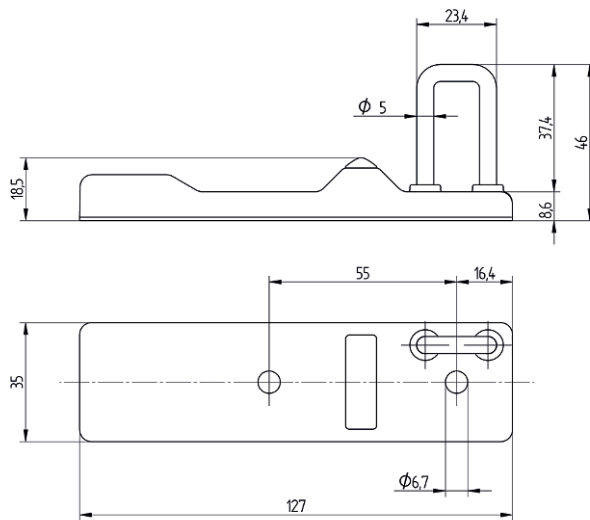

Mounting plate Z2FM001

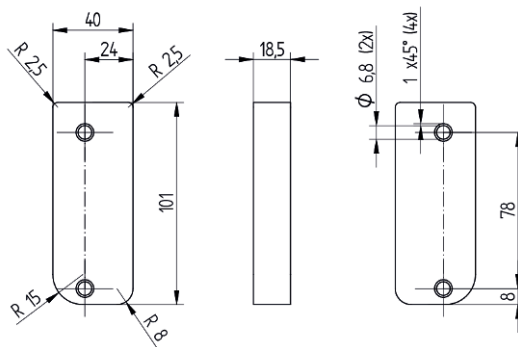

Dimensions in mm (1 mm = 0.03937 inch)

4.5 Complementary Products

wenglor offers you the right connection and mounting technology as well as other accessories for your product. You can find this at www.wenglor.com on the product details page at the bottom.

4.6 Structure

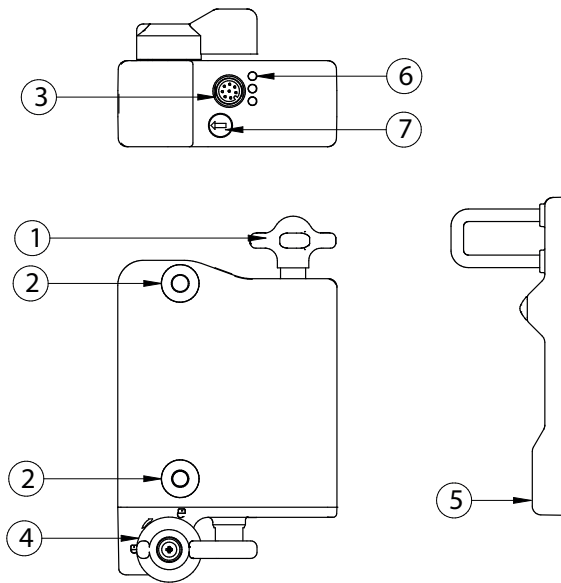

- ① Turnstile
- ② Mounting holes
- ③ connector plug
- ④ Escape release (only for S2FP002 and S2FP005)
- ⑤ Label and RFID chip (actuator)
- ⑥ Diagnostic LEDs (green, red, yellow)
- ⑦ Auxiliary release

5 Installation

5.1 General installation instructions



CAUTION

1. Please observe the instructions in standards EN ISO 12100, EN ISO 14119, and EN ISO 14120.
2. The actuator must be permanently mounted on the protective device using suitable measures (use of one-way screws, gluing, drilling out screw heads, pinning) and secured against displacement.

- There are two mounting holes for M6 screws (tightening torque: 6–7 Nm) for attaching the guard locking device and the actuator.
- The operating position is arbitrary. The system may only be operated if the angle between the locking device and the actuator is $\leq 2^\circ$.

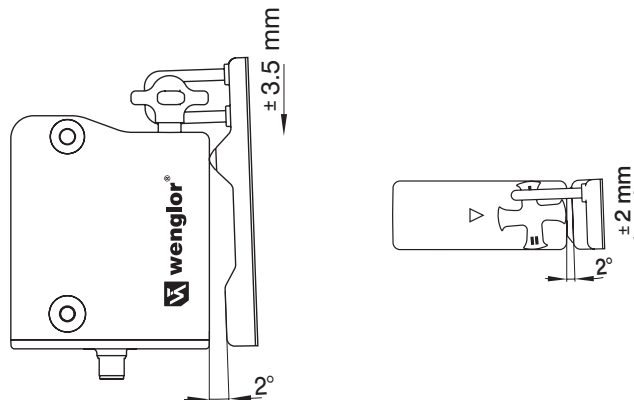

NOTICE

The guard locking device can be used as a stop.

Depending on the door dimensions and actuation speed, the mechanical service life may be reduced.

Installation of guard locking device and actuator

See the operating instructions for the corresponding actuator unit.

5.2 Actuating directions

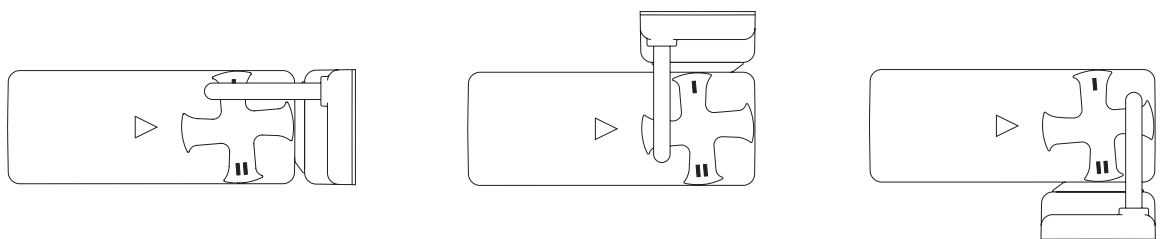

The illustrations show a closed protective device with a set latching force of 50 N (see section latching force [▶ 19]).



CAUTION

Ensure that the actuator engages sufficiently in the turnstile.



NOTICE

To avoid system-related interference and a reduction in switching distances, please observe the following instructions:

1. Metal parts in the vicinity of the guard locking device can change the switching distance.
2. Keep metal chips away.

5.3 Minimum distance

Minimum distance between two guard locking devices

or to other systems with the same frequency (125 kHz)

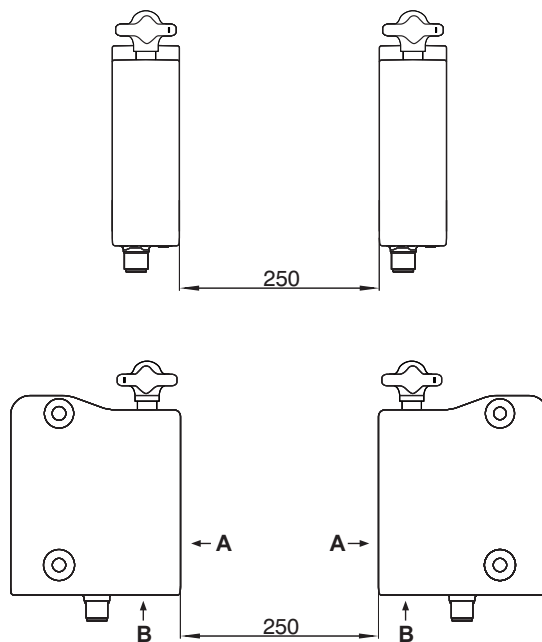

The minimum distance between metal mounting surfaces and the front side "A" and bottom side "B" of the device is 5 mm.

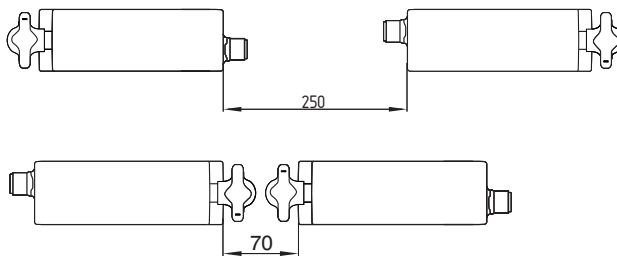

5.4 Auxiliary release

The guard locking device can be unlocked without tension for installation of the machine.

The guard locking device is unlocked by turning the auxiliary release to the "  " position.

Normal function is only restored after turning the auxiliary release back to the "  " position.



CAUTION

Do not turn beyond the stop.

The auxiliary release must be protected against unintentional actuation, e.g., by using the enclosed seal after initial start-up.

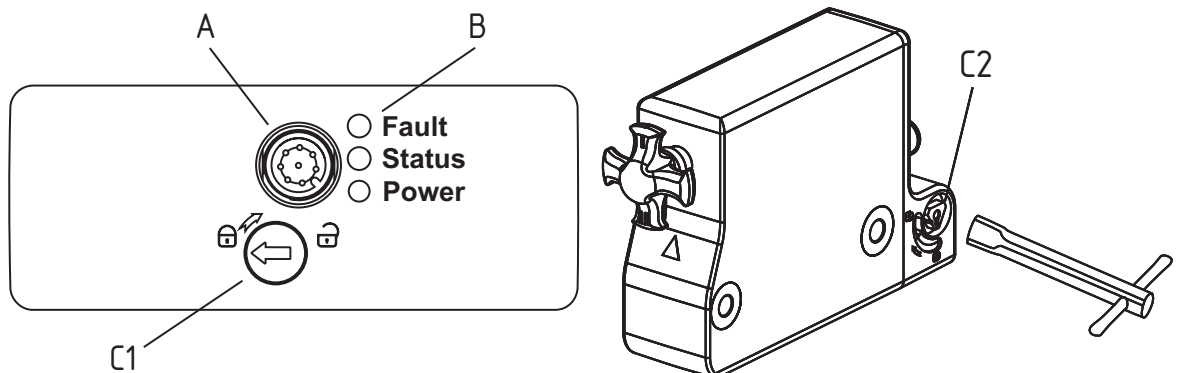

Legend

A: M12 installation plug, 8-pin

B: LED displays

C1: Auxiliary release using flat-head screwdriver

C2: Auxiliary release using TK-M5 triangular key

The auxiliary release must be protected against unintentional operation, e.g., by using the enclosed seal after initial start-up.

5.5 Installation with mounting plate

For doors that are flush with the door frame, the optional mounting plate Z2FM001 can be used.

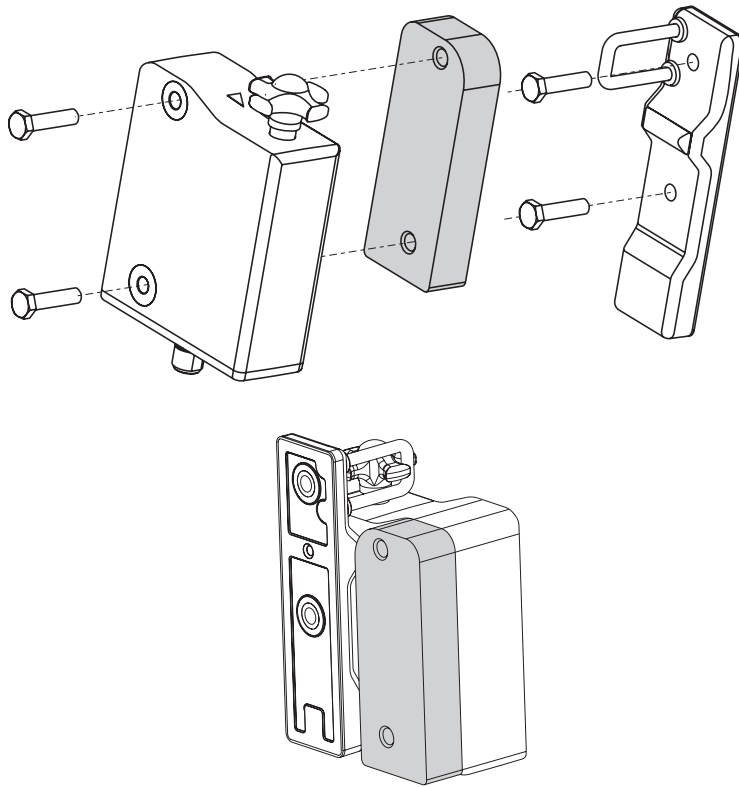

6 Initial Start-Up

6.1 Electrical connection



⚠ CAUTION

1. The electrical connection may only be carried out when the power is off and by authorized personnel.
2. The voltage inputs "+", "IN1", "IN2" and "Mag" must be protected against permanent overvoltage.
3. PELV power supply units in accordance with EN 60204-1 must be used.
4. The necessary electrical wiring and device protection must be provided in the installation.
5. The safety outputs can be used directly for connection in the safety-relevant part of the user control system.

6.1.1 How the safety outputs work

Opening the protective device causes the safety outputs to be switched off.

If the safety outputs are already switched on, errors that do not immediately jeopardize the safe function of the safety interlock (e.g., excessive ambient temperature, safety output at external potential, cross-short circuit) result in a warning message, the diagnosis output being switched off, and the safety outputs being switched off with a delay. The safety outputs switch off when the error warning has been pending for 30 minutes. The signal combination of the diagnosis output being switched off and the safety outputs still being switched on can be used to move the machine to an orderly stop position. After the error has been rectified, the error message is acknowledged by opening the corresponding safety door.

6.1.2 Requirements for downstream evaluation

- Two-channel safety input, suitable for 2 PNP output.
- When connecting the safety sensor to electronic safety evaluations, we recommend setting a discrepancy time of at least 100 ms. The safety inputs of the evaluation should be able to suppress a test pulse of approx. 1 ms.
- Cross-circuit detection in the evaluation is not necessary and should be switched off if required.

6.1.3 Series connection

- Series connection is possible.
- The risk time remains unchanged and the response time increases by the sum of the response times of the inputs specified in the technical data for each additional device.
- The number of devices is only limited by the line losses and the external line protection, in accordance with the technical data.



⚠ WARNING

The application and interpretation of the safety chain are to be performed by the user in accordance with the relevant standards and regulations, depending on the required safety level. If several safety sensors are involved in the same safety function, the PFH values of the individual components must be added together.



NOTICE

The overall concept of the control system in which the safety component is integrated must be validated in accordance with the relevant standards.

6.1.4 Connection Example

The connection example shown is a suggestion that does not exempt the application from carefully checking the circuit with regard to its suitability in each individual case.

Connection example 1: series connection

- The voltage is fed into the two safety inputs at the last guard locking device in the chain (as seen from the evaluation).
- The safety outputs of the first safety guard locking device are fed to the evaluation. The signal output can be connected to a PLC, for example.

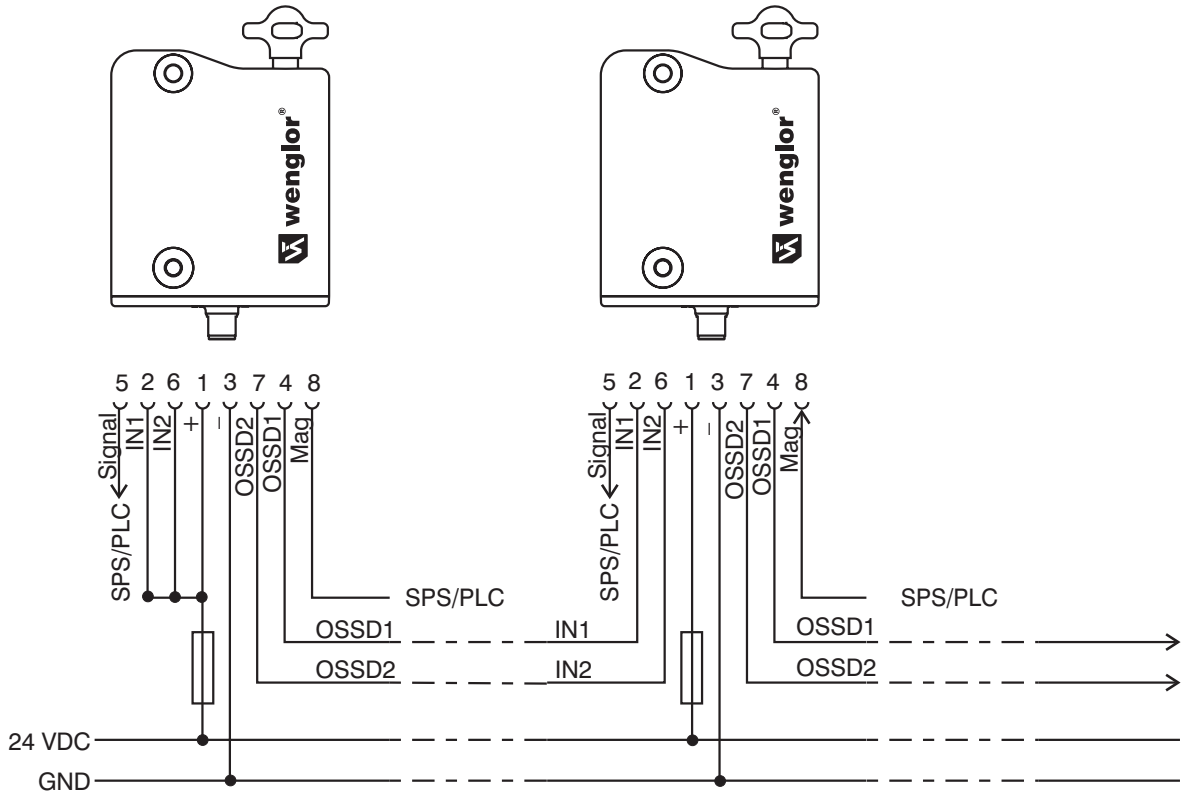

6.2 Magnet control

In the quiescent current variant, the locking device is unlocked when the "Mag" signal (= 24 V) is set during operation.

6.3 Actuator coding

Individually coded guard locking devices and actuators are taught to each other according to the following procedure:

1. Switch off the guard locking device and then switch it back on again.
2. Bring the actuator into the range. The learning process is signaled on the guard locking device: the green LED is switched off, the red LED lights up, and the yellow LED flashes (1 Hz).
3. After 10 seconds, shorter yellow flashing pulses (3 Hz) request that the operating voltage of the guard locking device be switched off. (If the voltage is not switched off within 5 minutes, the guard locking device interrupts the learning process and signals an incorrect actuator by flashing red 5 times).
4. The next time the operating voltage is switched on, the actuator must be detected again to activate the programmed actuator code. The activated code is then permanently stored.

The process of teaching a new actuator can be repeated an unlimited number of times. When a new actuator is taught, the previous code becomes invalid. A ten-minute release lock then ensures increased protection against manipulation. The green LED flashes until the release lock time has expired and the new actuator has been detected. If the power is interrupted during the timeout, the 10-minute manipulation safety period restarts.

6.4 Latching force

For the device to function properly, the turnstile must be in position I or II when the protective device is open. Locking is not possible in the intermediate positions.

Turning the turnstile 180° changes the latching force.

In position I, the latching force is approx. 25 N.

In position II, the latching force is approx. 50 N.

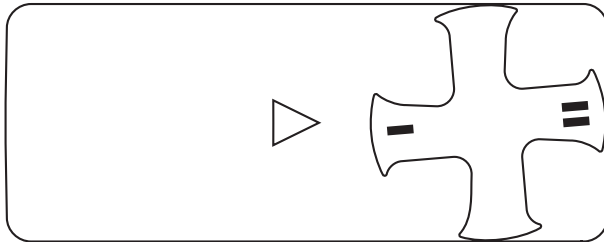

7 Maintenance instructions

The guard locking device must be tested with regard to its safety function. When installed correctly and used as intended, the guard locking device is maintenance-free. We recommend performing a visual and functional inspection at regular intervals, including the following steps:

1. Check that the guard locking device and actuator are securely fastened.
2. Check the max. lateral offset of the actuator unit and guard locking device.
3. Check the maximum angular offset (see section on installation [► 13]).
4. Check the integrity of the cable entry and connections.
5. Check the switch housing for damage.
6. Remove any dirt.



CAUTION

During all operational phases of the guard locking device, appropriate design and organizational measures must be taken for protection against manipulation or against circumvention of the safety device, for example by using a replacement actuator.



CAUTION

Damaged or defective devices must be replaced.

8 Diagnosis

8.1 Diagnostic information

The guard locking device signals the operating status, but also malfunctions, via three different colored LEDs.

Green (power)	Supply voltage present			
Yellow (status)	Operating status			
Red (fault)	Fault (see table of flashing codes for red diagnostic LED)			
	Flashing codes (red)	Description	Automatic shut-down after	cause of error
	1 flashing pulse	Error (warning) at output OSSD 1	30 min	Error in output test or voltage at output "OSSD 1" even though the output is switched off.
	2 flashing pulses	Error (warning) at output OSSD 2	30 min	Error in output test or voltage at output "OSSD 2" even though the output is switched off.
	3 flashing pulses	Error (warning) cross-connection	30 min	Cross-short between the output lines or error at both outputs. After 30 minutes, voltage must be switched off/on.
	4 flashing pulses	Error (warning) Overtemperature	30 min	Temperature measurement indicates excessive internal temperature
	5 flashing pulses	Error on actuator	0 min	Incorrect or defective actuator, broken bracket, interference with the RFID signal
	6 flashing pulses	Turnstile error	0 min	Turnstile in an unauthorized intermediate position
	Red steady light	Internal error	0 min	Device defective

System status	LED		
	Green	Red	Yellow
No input signal at IN1 and/or IN2			
Door open and a door in the series connection in front of it is also open	flashing (1 Hz)	off	off
Door closed and a door in the series connection in front of it is open	flashes (1 Hz)	off	flashing
Door locked and a door in the series connection in front of it is open	flashing (1 Hz)	off	on

8.2 Signal output

The short-circuit-proof signal output can be used for central displays or control tasks, e.g., in a PLC.



WARNING

→ The signal output is not a safety-related output!

Signal output behavior

Input signal Magnet control

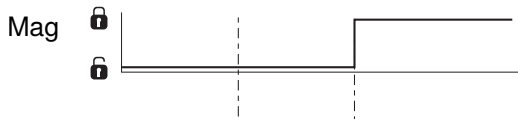

Legend

- Lock
- Unlock
- Door open
- Lock time
- Door closed
- Door locked
- Door not locked or error

Normal operation, door was locked



Door could not be locked or error



Evaluation signal output

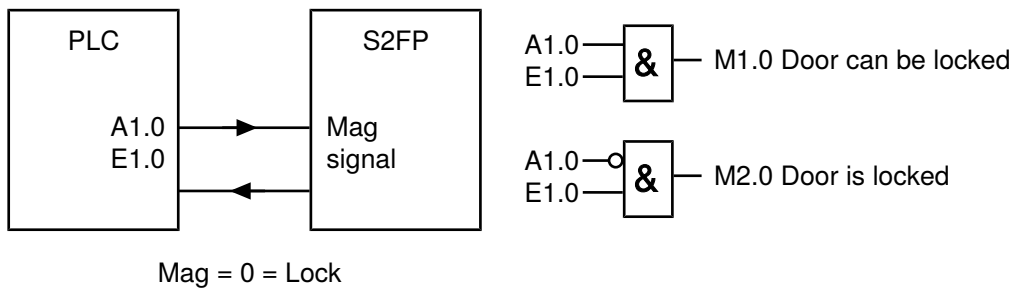

Diagnostic information for the safety switching device

The safety switching device signals the operating status, but also faults, via three different-colored LEDs on the device.

System status	Magnetic control Mag	LED			Safety out-puts OSSD 1, OSSD 2	signal out-put Signal
		Green	red	Yellow		
Door open	24 V (0 V)	On	off	off	0 V	0 V
Door closed, not locked	24 V	on	off	flashing	24 V	24 V
Door closed, locking not possible	0 V	on	off	flashing	24 V	0 V
Door closed and locked	0 V	on	Off	on	24 V	24 V
Error warning ¹⁾	0 V	on	flashing ²⁾	on	24 V ¹⁾	0 V
Error	0 V (24 V)	on	flashing ²⁾	off	0 V	0 V
No input signal at IN1 and/or IN2	0 V (24 V)	flashing	off	off	0 V	0 V

System status	Magnetic control Mag	LED			Safety outputs OSSD 1, OSSD 2	signal output Signal
		Green	red	Yellow		
No input signal at IN1 and/or IN2	0 V (24 V)	flashing	off	on/flashing	0 V	24 V
Actuator Teaching started		Off	on	flashing	0 V	0 V
Actuator Teaching process (release lock)		flashing	off	off	0 V	0 V

¹⁾ after 30 minutes → error

²⁾ See flashing code table in section Diagnostic information [► 21]

8.3 Errors

Errors that no longer guarantee the safe function of the safety switching device (internal errors) lead to the safety outputs being switched off within the risk time. After the error has been rectified, the error message is acknowledged by opening the corresponding safety door and closing it again.

8.4 Error warning

An error that does not immediately jeopardize the safe functioning of the safety switching device (e.g., excessive ambient temperature, safety output at external potential, cross-connection) leads to delayed shutdown (see Diagnostic information [► 21]). This signal combination "diagnosis output switched off" and "safety outputs still switched on" can be used to move the machine to an orderly stop position.

An error warning is withdrawn when the cause is eliminated.

If the error warning is active for 30 minutes, the safety outputs are also switched off (red LED flashes, see Diagnostic information [► 21]).

9 **Disassembly**

The guard locking device may only be dismantled when the power is disconnected.

10 Proper Disposal

wenglor sensoric GmbH does not accept the return of unusable or irreparable products. Respectively valid national waste disposal regulations apply to product disposal.

11 Declarations of Conformity

Declarations of conformity can be found on our website at www.wenglor.com in the product's separate download area.