



LSLx00x

OPERATING INSTRUCTIONS

wenglorTPL

PREAMBLE

This Technical User Guide contains warnings and guidance for correct and safe operation of the product. These instructions must be followed at all times. wenglorTPL will not be held responsible for problems caused by using the product contrary to these instructions and the Warranty will be deemed invalid.



UNPACKING

This product is packed at the factory using suitable materials for safe transport. To open the package, do not use any cutting blade to avoid damaging the product(s). Please use the delivered accessories if needed. (Do not use any other products or equivalents to replace the delivered accessories).

In the event of damage occurring during shipping, it must be reported to the carrier at time of delivery (including noting the damage in writing on the delivery documents). It is also your responsibility to notify wenglorTPL in writing of the damage within 24 hours of receipt of the package. If these instructions are not followed, wenglorTPL reserves the right not to accept requests for return and exchange of damaged products.

RISK CLASS

The applicable Standard EN-62471 classifies LED Lighting into 4 classes according to their degree of hazard severity. The table below summarises the risks associated with our standard products.

Colour	Class	Risk
Red 630 nm, IR 850 nm	1	low
White WHI (5700K)	2	moderate

wenglorTPL can provide **guidance notes to minimise photo-biological risks**, including the nominal minimum operating distance. Please contact wenglorTPL through your **usual representative** for this information.

In all cases, wenglorTPL recommends the use of **protection glasses**.



Please be careful with the variable optics on this product. With the minimum beam angle (lens at maximum height) the light is extremely focused. This presents an eye safety issue, particularly with direct emissions from a short working distance.



LSLx00x

OPERATING INSTRUCTIONS

P2/12

OVERVIEW

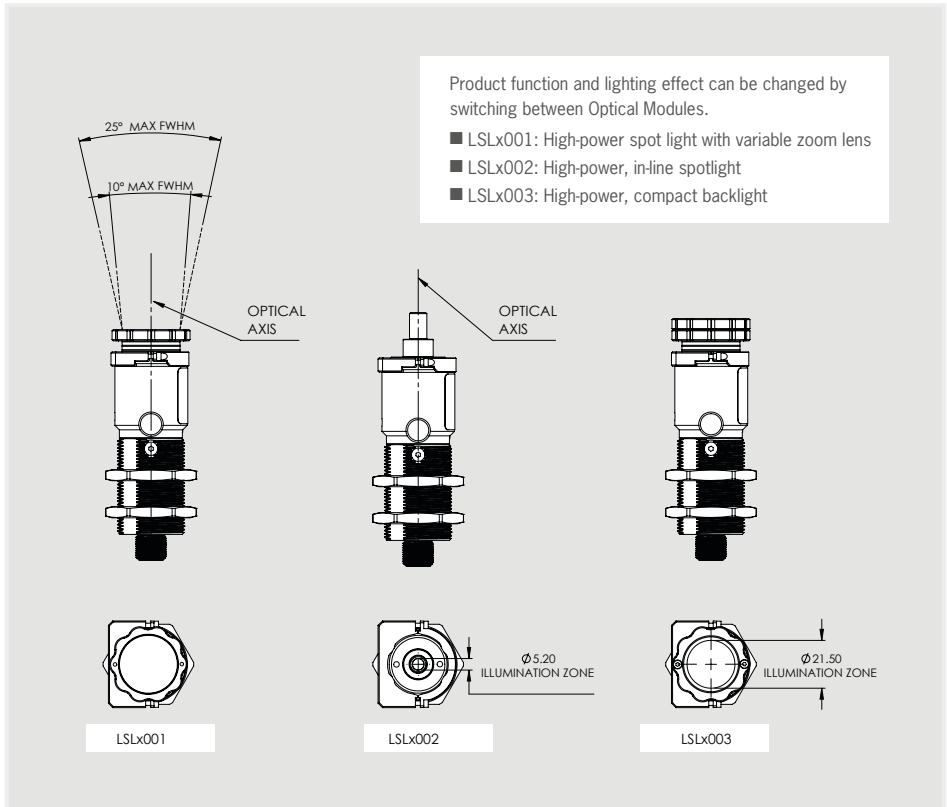

LED INDICATORS

The power supply is equipped with 2 LED indicators :

- **N°1:** indicates that the light is powered but the LEDs are not turned ON with this indicator alone.
- **N°2:** indicates that the LEDs are switched on.

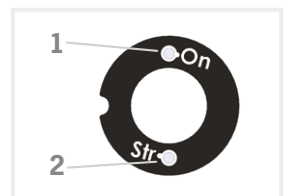



DIMENSIONS: ZOOM SPOTLIGHT

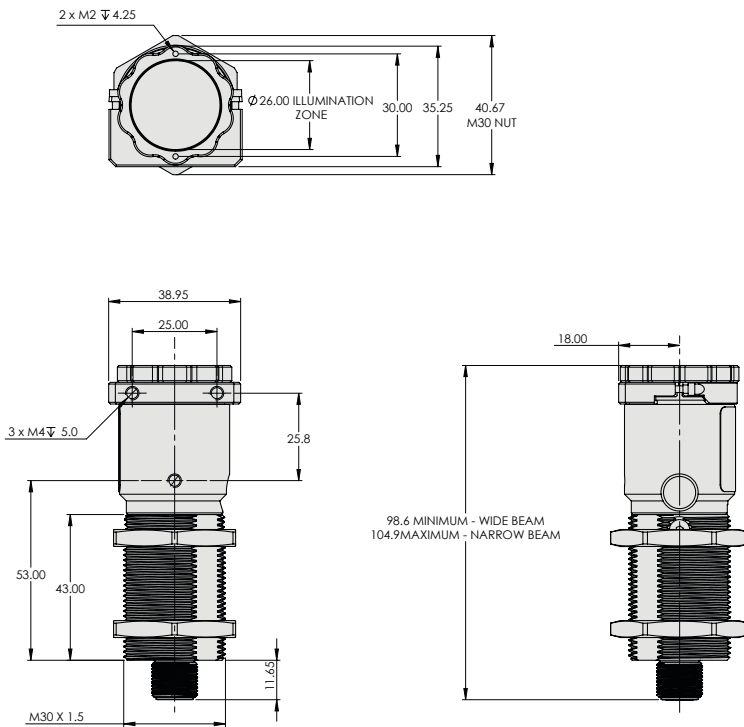

	Max length	Min length	Width
LSLx001	104.9 mm	98.6 mm	40.67 mm



DIMENSIONS: BACKLIGHT SPOTLIGHT

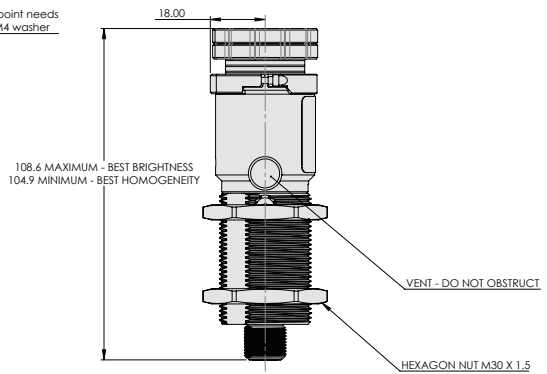
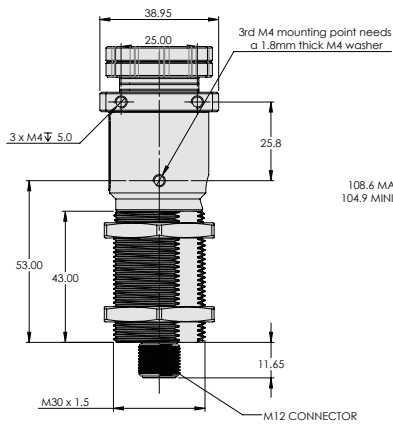
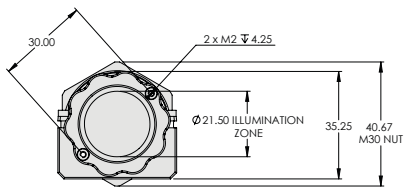

	Max length	Min length	Width
LSLx003	108.6 mm	104.9 mm	40.67 mm



LSLx00x

OPERATING INSTRUCTIONS

P6/12

LOCKING RING FOR THE ADJUSTABLE OPTICAL MODULE

NOTE: Rotating the Optical Module requires significant force but should be possible by hand. This is due to the product's robust construction designed to meet the IP67 rating.

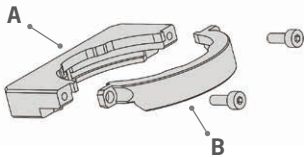

The **LSLx00x** comes with a locking ring which enables the user to lock the position of the Optical Module. The **LSLx00x** and the locking ring are delivered within the same package, they need to be assembled.

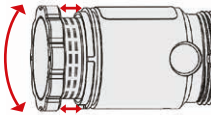

1) Begin by setting the desired working distance of the light by rotating the Optical Module.

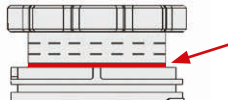

2) Be careful to not rotate the zoom lens past the final distance indication line, unless swapping modules.

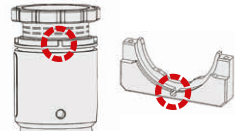

3) To correctly position the locking ring on the LSLx00x locate the central key indicated in red and align with notch in locking ring A.

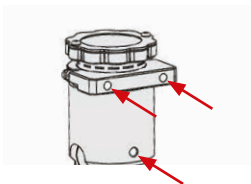

4) Validate the correct orientation of the locking ring by visually checking that all three M4 fastening points are aligned on the same side.

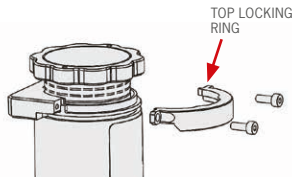

5) Complete the assembly of the locking ring by connecting the remaining fasteners and top locking ring. Tighten the locking ring screw with a 1.5mm Allen key.

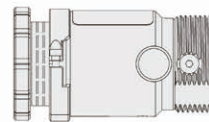

6) This adjustment will only need to be made once. Once the lens has been adjusted and locked using the locking ring, it will be fixed in place. The working distance of the product cannot be altered until manually adjusted.



DO NOT HOLD THE M12 CONNECTOR WHEN ROTATING THE LENS.



FIXING: M30 X 1.5mm NUTS

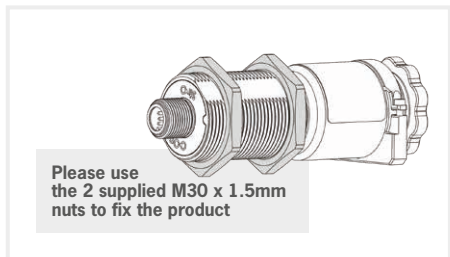

As part of the setup process, it is imperative to ensure the light is switched off and unplugged for safety and proper installation.

MOUNTING POINTS

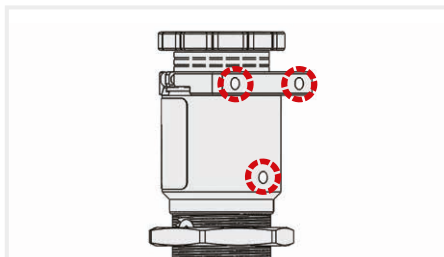

The LSLx00x features three M4 mounting points spaced along its body, providing versatile options for securely attaching and mounting the product. For the lower M4 mounting point, a 1.8mm thick M4 washer is required to ensure proper installation and stability.

CONNECTION

M12 Connector 5 male points

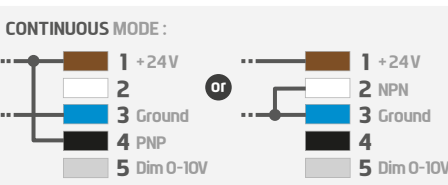
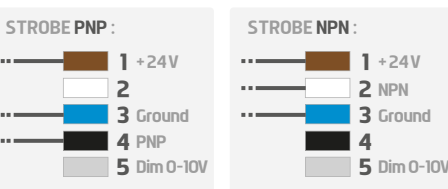
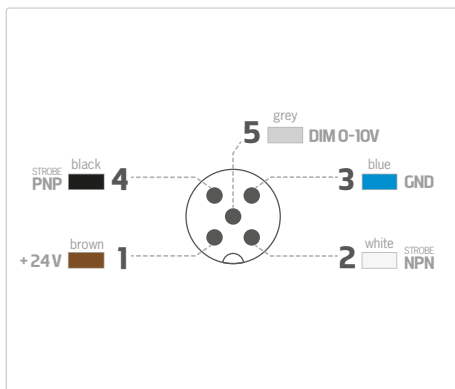

EMC IMMUNITY CONNECTIONS: for greater EMC immunity when using the light under Strobe operation, configure the signal connections as illustrated here. For Dimming, the Pin (5) should be connected to a voltage between 0V and 10V to ensure light output is correctly configured.

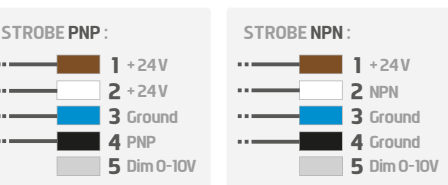



LSLx00x

OPERATING INSTRUCTIONS

CONTROL

The product is optimised for a lifespan >50kh in a 40°C (104°F) atmosphere.
 In strobe mode, the strobing time is directly equivalent to the time during which the strobe entry is activated.

STROBE PNP & NPN:

- **PNP** : from 5 to 24V for 100% ON. From 0 to 2V for 100% OFF.
- **NPN** : less than 1V for 100% ON. Above 1.5V for 100% OFF. Max 20V.

Brightness	D max	t max	f max
30% to 100%	N/A	CW	N/A
100% to 300%	20%	10 ms	700Hz

CW : Continuous Working
 D : Duty Cycle
 t : pulse duration
 f : frequency

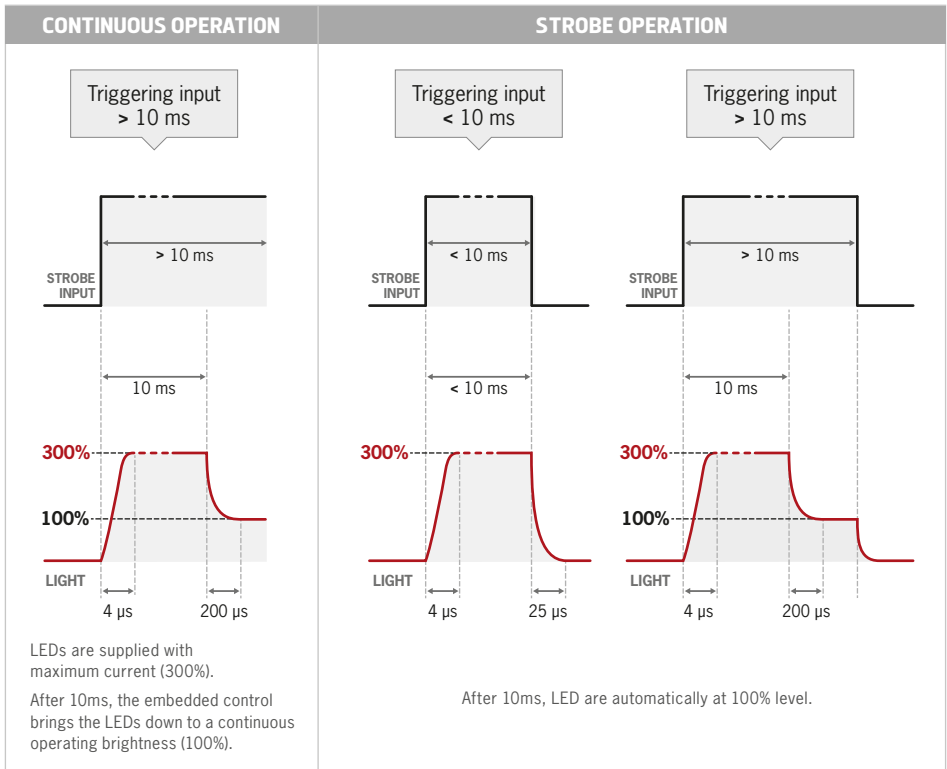



POWER SUPPLY

	LSLx00x
Consumption CW mode	6W
Consumption Strobe mode*	13.2W
Min. functioning Voltage	20V in the light input
Normal functioning Voltage	24V in the light input (±10%)
Max. functioning Voltage	27V in the light input
Max. consumption Strobe and Dimming signal	10mA

*Strobed with 20% duty cycle – this is the peak consumption. You must use a power supply with this rating.

DIMMING 0-10V ON PIN 5

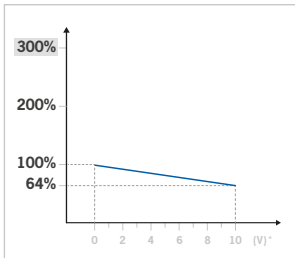

CONTINUOUS WORKING

Dimming during continuous working (CW) operation

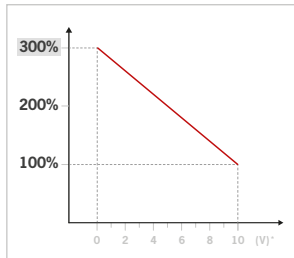

STROBE OVERDRIVE ≤10ms ON TIME

Dimming during strobe mode
≤10ms maximum on time

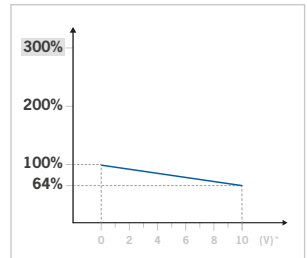

STROBE >10ms ON TIME

Dimming during strobe mode after LEDs are ON for more than 10ms

* Voltage applied to PIN 5.

OPERATING CONDITIONS

-10° to +40°C (14° to +104°F) / 80% of humidity without condensation.

No thermal shock (max temperature variation: 10°C (18°F) in 24h). Not for outdoor use.



LSLx00x

OPERATING INSTRUCTIONS

P10/12

■ ADDITIONAL ACCESSORIES

Polariser



Secure the polarizer attachment in place using the two supplied M2 screws

Ref: ZSLG001

Mounting Accessory



Ref: ZVZZ001 *

* Requires ZSLZ001 or W30 for compatibility.

Mounting Plate



M4 screws supplied, to securely attach the mounting plate to the body of the LSLx00x.

Ref: ZSLZ001

Mounting Accessory



Ref: W30

Extra M30 Nuts



Ref: MUTTER-M30

Mounting Accessory



Ref: W30S12AL



■ USER SAFETY

Do not modify or dismantle all or part of the product.

Respect the power supply voltages and the connection terminals.

Ensure power supply is switched off whilst connecting product and turn on only once product is fully connected. Failure to do this may damage the product and invalidate the Warranty

Do not stare at the lighting source directly.

Follow advice below for installation to minimise operator exposure to the light source.



INSTALLATION GUIDANCE:

- Forbid or limit the direct access to the lighting source (exposure into the radiation axis).
- Establish a security perimeter to prevent the operators from approaching the lighting source beyond the recommendations of the manufacturer.
- If the workstation permits it, introduce a filter that will stop the lighting radiation under a fixed or adjustable frame between the source and the operator. When these measures cannot be implemented, supply the operators with glasses (class 4) available from wenglorTPL.

It is the responsibility of the persons installing this product to ensure that all means possible (such as those stated above) have been implemented to reduce exposure of the machine operators to the light emitted from this product.



High ambient temperatures and insufficient heat dissipation can lead to hot housing surfaces. Do not touch the light during operation. Keep a minimum distance of 20 mm between the light and thermally insulating surfaces or mount the light on a thermally conductive surface.

■ EQUIPMENT MAINTENANCE

CLEANING (when the product is switched off)

Please use a soft and dry cloth. Do not use any abrasive material. Do not use any cleaning solvent or aggressive chemical product. wenglorTPL recommends to use isopropyl alcohol.

wenglorTPL

wenglor Straße 3
88069 Tettnang
Germany

+49 (0)7542 5399 800

support@wenglor.com



www.wenglor.com