

# Retro-Reflex Sensor

## P1NL401S01

## LASER

Part Number



- Condition monitoring
- Detect extremely small parts starting at 0.75 mm
- High switching frequency
- IO-Link 1.1

The retro-reflex sensor works with a fine laser beam and a reflector. The laser class 1 collimated laser beam detects objects, for instance, when checking installation, feed or presence, starting at a size of 0.75 mm over the entire range. The IO-Link interface can be used to configure retro-reflex sensors (PNP/NPN, NC/NO, switching distance) and to output switching statuses and signal values.

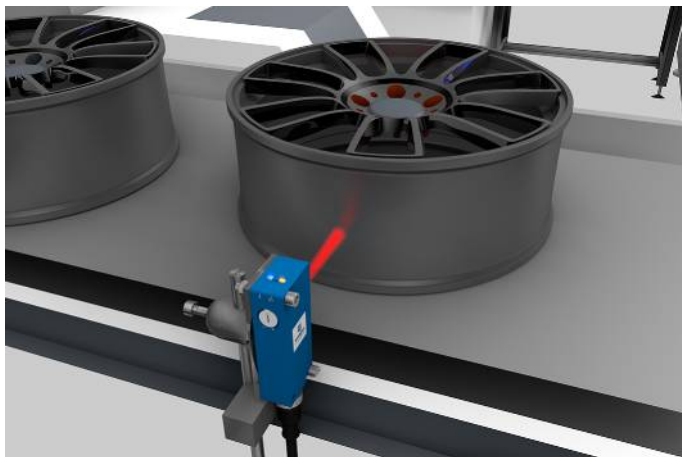

### Technical Data

Optical Data	
Range	9500 mm
Reference Reflector/Reflector Foil	RE6151BM
Min. Distance to Reflector	0 mm
Smallest Recognizable Part	see Table 2
Switching Hysteresis	< 15 %
Light Source	Laser (red), collimated
Polarization Filter	yes
Service Life (T = +25 °C)	100000 h
Laser Class (EN 60825-1)	1
Max. Ambient Light	10000 Lux
Light Spot Diameter	see Table
Single-Lens Optic	yes
Electrical Data	
Supply Voltage	10...30 V DC
Supply Voltage with IO-Link	18...30 V DC
Current Consumption (U <sub>b</sub> = 24 V)	< 20 mA
Switching Frequency	2000 Hz
Switching frequency (speed mode)	3500 Hz
Response Time	0,25 ms
Response time (speed mode)	0,14 ms
Temperature Drift	< 10 %
Temperature Range	-25...60 °C
Switching Output Voltage Drop	< 2 V
Switching Output/Switching Current	100 mA
Residual Current Switching Output	< 50 µA
Short Circuit Protection	yes
Reverse Polarity Protection	yes
Overload Protection	yes
Interface	IO-Link V1.1
Protection Class	III
FDA Accession Number	1911373-000
Mechanical Data	
Setting Method	Potentiometer
Housing Material	Plastic, ABS
Degree of Protection	IP67/IP68
Connection	M12 × 1; 4-pin
Optic Cover	PMMA
Safety-relevant Data	
MTTFd (EN ISO 13849-1)	2733,11 a
IO-Link	●
PNP NO/NC antivalent	●
Connection Diagram No.	<b>215</b>
Control Panel No.	<b>A28</b>
Suitable Connection Equipment No.	<b>2</b>
Suitable Mounting Technology No.	<b>350</b>

### Complementary Products

Dust Extraction Tube STAUBTUBUS-03
IO-Link Master
Reflector, Reflector Foil
Set Protective Housing Z1NS001
Software

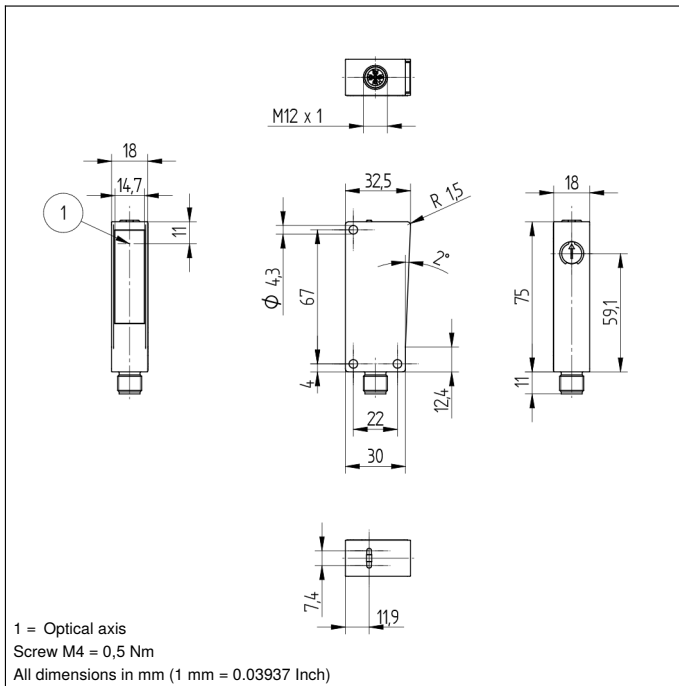

### Ctrl. Panel

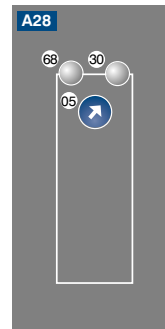

05 = Switching Distance Adjuster  
 30 = Switching Status/Contamination Warning  
 68 = supply voltage indicator

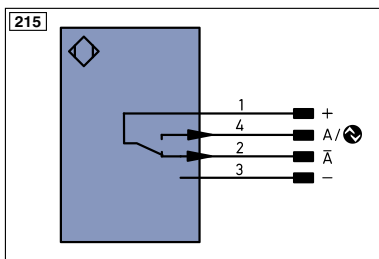

Legend			
+	Supply Voltage +	PT	Platinum measuring resistor
-	Supply Voltage 0 V	nc	not connected
~	Supply Voltage (AC Voltage)	U	Test Input
A	Switching Output (NO)	U	Test Input inverted
Ā	Switching Output (NC)	W	Trigger Input
V	Contamination/Error Output (NO)	W-	Ground for the Trigger Input
V̄	Contamination/Error Output (NC)	O	Analog Output
E	Input (analog or digital)	O-	Ground for the Analog Output
T	Teach Input	BZ	Block Discharge
Z	Time Delay (activation)	AWV	Valve Output
S	Shielding	a	Valve Control Output +
RxD	Interface Receive Path	b	Valve Control Output 0 V
TxD	Interface Send Path	SY	Synchronization
RDY	Ready	SY-	Ground for the Synchronization
GND	Ground	E+	Receiver-Line
CL	Clock	S+	Emitter-Line
E/A	Output/Input programmable	⊕	Grounding
	IO-Link	SrR	Switching Distance Reduction
PoE	Power over Ethernet	Rx+/-	Ethernet Receive Path
IN	Safety Input	Tx+/-	Ethernet Send Path
OSSD	Safety Output	Bus	Interfaces-Bus A(+)/B(-)
Signal	Signal Output	La	Emitted Light disengageable
Bl_D+/-	Ethernet Gigabit bidirect. data line (A-D)	Mag	Magnet activation
EN0.6542	Encoder 0-pulse 0-0 (TTL)	RES	Input confirmation
		EDM	Contacting Monitoring
		EN0.6542	Encoder A/Ā (TTL)
		EN0.6542	Encoder B/B̄ (TTL)
		ENa	Encoder A
		ENb	Encoder B
		AMIN	Digital output MIN
		AMAX	Digital output MAX
		AOK	Digital output OK
		SY_in	Synchronization In
		SY_OUT	Synchronization OUT
		OLT	Brightness output
		M	Maintenance reserved
		rsv	reserved
			Wire Colors according to IEC 60757
		BK	Black
		BN	Brown
		RD	Red
		OG	Orange
		YE	Yellow
		GN	Green
		BU	Blue
		VT	Violet
		GY	Grey
		WH	White
		PK	Pink
		GNVE	Green/Yellow

**Table 1**

Working Distance	2 m	5 m	9,5 m
Light Spot Diameter	20 mm	50 mm	70 mm

**Table 2**

Distance, Sensor to Reflector	2 m	5 m	9,5 m
Smallest Recognizable Part	0,75 mm	5 mm	8 mm

### Feasible reflector distance

Reflector type, mounting distance

RQ100BA	0,07...9,5 m	RR21_M	0...1,8 m
RE18040BA	0,07...6 m	Z90R004	0...3,9 m
RQ84BA	0,07...8 m	Z90R005	0...5,3 m
RR84BA	0,07...9,5 m	ZRAE02B01	0,07...4,5 m
RE9538BA	0...3 m	ZRME01B01	0...1 m
RE6151BM	0...9,5 m	ZRME03B01	0...3,8 m
RR50_A	0,06...8,5 m	ZRMR02K01	0...1,5 m
RE6040BA	0,07...9 m	RF505	0...1,5 m
RE8222BA	0,06...5 m	RF508	0...1,6 m
RR34_M	0...4,5 m	RF258	0...1,5 m
RE3220BM	0...5 m	ZRAF08K01	0...1,5 m
RE6210BM	0...2 m	ZRDF03K01	0...6 m
RR25_M	0...3,3 m	ZRDF10K01	0...6 m
RR25KP	0...1,3 m		

