

Reflex Sensor with Background Suppression

OPT1510

Part Number



- Energy savings thanks to EcoMode
- Optimized performance
- Quick wiring
- Scaled switching distance adjuster
- Time-saving installation with fast-clip mounting system

These sensors have been specially designed for use in accumulation roller conveyors. Their compact design allows for installation between rollers below the transport level. High-precision background suppression makes it possible to reliably detect even black objects at up to 900 mm. The scaled switching-distance adjuster assures quick and simple adjustment to the desired distance. Thanks to the innovative fast-clip mounting system and quick wiring, the sensor are installed and ready for use in no time flat.

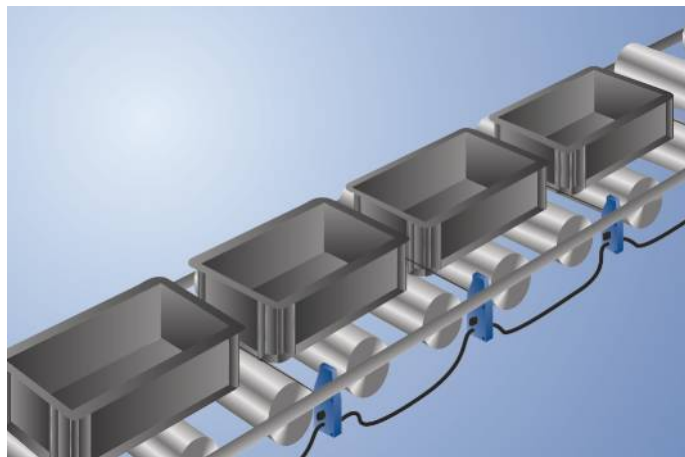

Technical Data

Optical Data	
Range	900 mm
Switching Hysteresis	< 5 %
Light Source	Infrared Light
Wavelength	860 nm
Service Life (T = +25 °C)	100000 h
Risk Group (EN 62471)	1
Max. Ambient Light	90000 Lux
Opening Angle	3 °

Electrical Data	
Supply Voltage	20,6...30 V DC
Current Consumption Sensor (U _b = 24 V)	< 16 mA
EcoMode	yes
Switching Frequency	100 Hz
Response Time	5 ms
Temperature Drift	< 5 %
Temperature Range	-40...60 °C
Number of Switching Outputs	1
Switching Output Voltage Drop	< 0,9 V
PNP Switching Output/Switching Current	200 mA
Short Circuit Protection	yes
Reverse Polarity Protection	yes
Overload Protection	yes
Logic	yes
Single Discharge	yes
Block Forwarding	yes
Solenoid Valve	yes
Protection Class	III

Mechanical Data	
Setting Method	Potentiometer
Housing Material	Plastic, ABS/GF
Degree of Protection	IP65
Connection	M12 × 1; 4-pin
Cable Length	1,5 m

Pneumatic Solenoid Valve Unit	
Valve no.	K25
Supply Voltage Valve	19,2...28,8 V
Current Consumption Valve	86 mA
Valve temperature range	-15...50 °C
Operating Pressure	0...4 bar
Nominal Width	1,2 mm
Nominal flow rate 1 -> 2	50 NL/min
Supply-Line Connector Pipe	2 × 8 × 1
Working-Line Connector Pipe	4 × 1
Valve function	3/2-Way
Switching function	NC

PNP NC	●
Connection Diagram No.	809
Control Panel No.	OP1
Suitable Connection Equipment No.	2 2s
Suitable Mounting Technology No.	421

Complementary Products

Adapter OPT70N, OPT70S, OPT70P
ZPTX001 Quick Mount

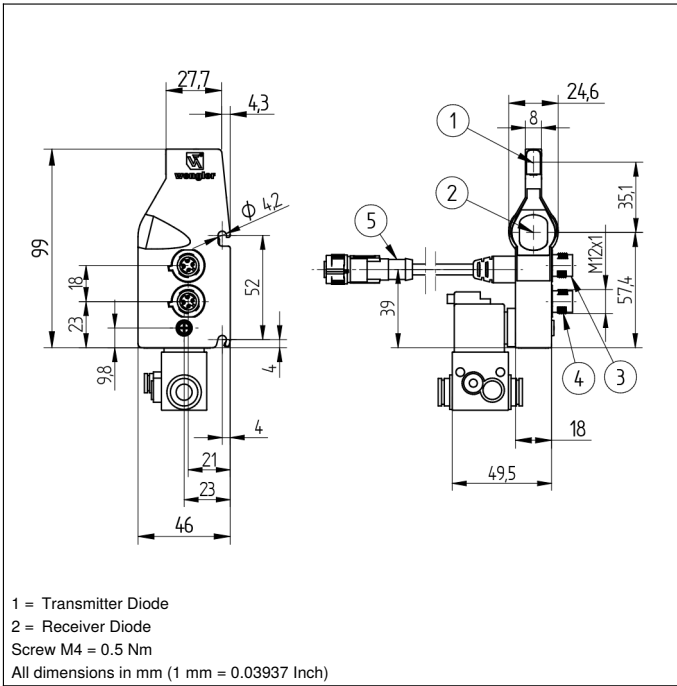

Ctrl. Panel

OP1



05 = Switching Distance Adjuster
 30 = Switching Status/Contamination Warning

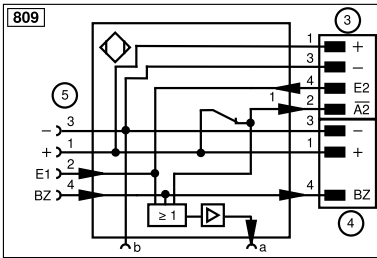

Legend

+	Supply Voltage +	nc	Not connected	ENBRS422	Encoder B/B̄ (TTL)
-	Supply Voltage 0 V	U	Test Input	ENA	Encoder A
~	Supply Voltage (AC Voltage)	Ü	Test Input inverted	ENb	Encoder B
A	Switching Output (NO)	W	Trigger Input	AMIN	Digital output MIN
Ā	Switching Output (NC)	W-	Ground for the Trigger Input	AMAX	Digital output MAX
V	Contamination/Error Output (NO)	O	Analog Output	AOK	Digital output OK
V̄	Contamination/Error Output (NC)	O-	Ground for the Analog Output	SY In	Synchronization In
E	Input (analog or digital)	BZ	Block Discharge	SY OUT	Synchronization OUT
T	Teach Input	Amv	Valve Output	OLT	Brightness output
Z	Time Delay (activation)	a	Valve Control Output +	M	Maintenance
S	Shielding	b	Valve Control Output 0 V	rsv	Reserved
RxD	Interface Receive Path	SY	Synchronization	Wire Colors according to DIN IEC 60757	
TxD	Interface Send Path	SY-	Ground for the Synchronization	BK	Black
RDY	Ready	E+	Receiver-Line	BN	Brown
GND	Ground	S+	Emitter-Line	RD	Red
CL	Clock	±	Grounding	OG	Orange
E/A	Output/Input programmable	SnR	Switching Distance Reduction	YE	Yellow
IO-Link	IO-Link	Rx+/-	Ethernet Receive Path	GN	Green
PoE	Power over Ethernet	Tx+/-	Ethernet Send Path	BU	Blue
IN	Safety Input	Bus	Interfaces-Bus A(+)/B(-)	VT	Violet
OSSD	Safety Output	La	Emitted Light disengageable	GY	Grey
Signal	Signal Output	Mag	Magnet activation	WH	White
BI_D+/-	Ethernet Gigabit bidirect. data line (A-D)	RES	Input confirmation	PK	Pink
ENo RS422	Encoder 0-pulse 0/0̄ (TTL)	EDM	Contact Monitoring	GNYE	Green/Yellow
PT	Platinum measuring resistor	ENARS422	Encoder A/Ā (TTL)		

Switching Distance Deviation

Typical characteristic curve based on white, 90 % remission

OPT15xx

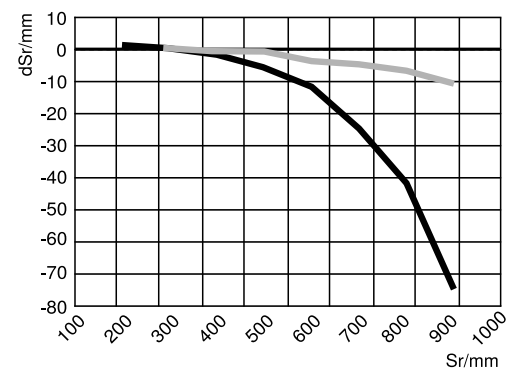

Sr = Switching Distance

dSr = Switching Distance Change

— black 6 % remission

— grey 18 % remission

