

Retro-Reflex Sensor

Universal

OLDK503O0002

Part Number



- Clever inclusive mounting technology
- Glossy objects can be detected
- IO-Link 1.1
- Minimal installation space
- Simple installation

The retro-reflex sensor works with red light and a reflector. It also reliably detects objects with reflective or glossy surfaces at high speeds. Thanks to its great range, the sensor can, for example, be used to manage feed and presence controls as well as to detect objects on wide feed belts. The IO-Link interface can be used to configure retro-reflective barriers (PNP/NPN, NC/NO, switching distance), as well as for reading out switching statuses and signal values.

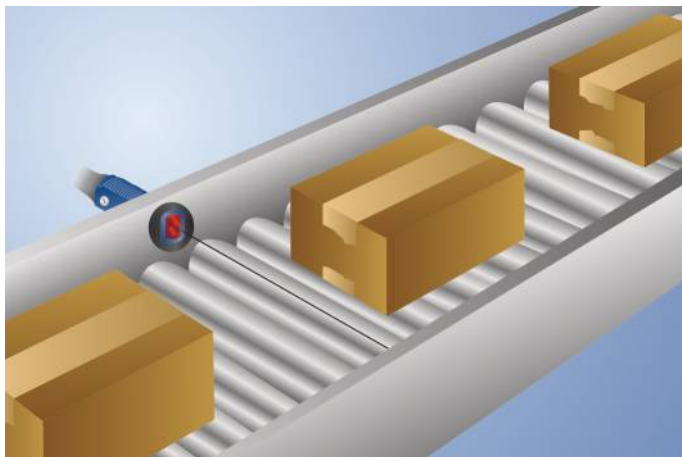

Technical Data

Optical Data	
Range	5000 mm
Reference Reflector/Reflector Foil	RQ100BA
Switching Hysteresis	< 15 %
Light Source	Red Light
Polarization Filter	yes
Service Life (T = +25 °C)	100000 h
Max. Ambient Light	10000 Lux
Opening Angle	5 °
Light Spot Diameter	see Table 1
Two-Lens Optic	yes

Electrical Data	
Supply Voltage	10...30 V DC
Supply Voltage with IO-Link	18...30 V DC
Current Consumption (U _b = 24 V)	< 30 mA
Switching Frequency	700 Hz
Switching frequency (speed mode)	900 Hz
Response Time	0,7 ms
Response time (speed mode)	0,6 ms
Temperature Drift	< 10 %
Temperature Range	-25...60 °C
Switching Output Voltage Drop	< 2,5 V
NPN Switching Output/Switching Current	200 mA
Residual Current Switching Output	< 50 μA
Short Circuit Protection	yes
Reverse Polarity Protection	yes
Overload Protection	yes
Lockable	yes
Interface	IO-Link V1.1
Protection Class	III

Mechanical Data	
Setting Method	Potentiometer
Housing Material	Plastic, ABS/GF
Degree of Protection	IP67
Connection	M12 × 1; 4-pin

Safety-relevant Data	
MTTFd (EN ISO 13849-1)	2953,75 a
Scope of delivery	1 × initial start-up instructions 1 × MUTTER-M8-E002 hex nut 1 × sensor 1 × Z0008 mounting console
Packaging unit	1 Piece

IO-Link	●
NPN NC, NPN NO	●
Connection Diagram No.	213
Control Panel No.	DK1
Suitable Connection Equipment No.	2
Suitable Mounting Technology No.	150

Complementary Products

Dust Extraction Tube STAUBTUBUS-01
IO-Link Master
Reflector, Reflector Foil
Software

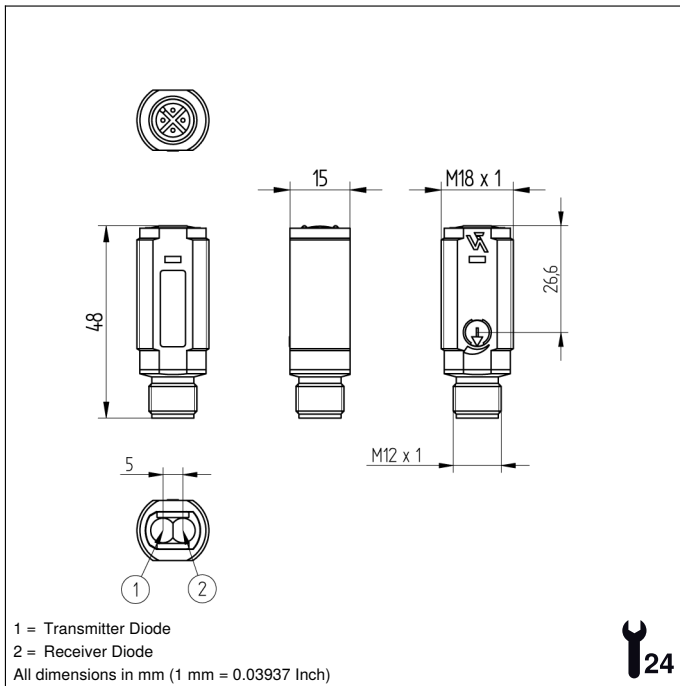

Ctrl. Panel

DK1

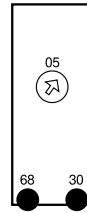

05 = Switching Distance Adjuster
 30 = Switching Status/Contamination Warning
 68 = Power LED



Legend			
+	Supply Voltage +	PT	Platinum measuring resistor
-	Supply Voltage 0 V	nc	Not connected
~	Supply Voltage (AC Voltage)	U	Test Input
A	Switching Output (NO)	Ū	Test Input inverted
Ā	Switching Output (NC)	W	Trigger Input
V	Contamination/Error Output (NO)	W-	Ground for the Trigger Input
Ṽ	Contamination/Error Output (NC)	O	Analog Output
E	Input (analog or digital)	O-	Ground for the Analog Output
T	Teach Input	BZ	Block Discharge
R	Reset input	Amv	Valve Output
Z	Time Delay (activation)	a	Valve Control Output +
S	Shielding	b	Valve Control Output 0 V
RxD	Interface Receive Path	SY	Synchronization
TxD	Interface Send Path	SY-	Ground for the Synchronization
RDY	Ready	E+	Receiver-Line
GND	Ground	S+	Emitter-Line
CL	Clock	⊕	Grounding
E/A	Output/Input programmable	SnR	Switching Distance Reduction
	IO-Link	Rx+/-	Ethernet Receive Path
PoE	Power over Ethernet	Tx+/-	Ethernet Send Path
IN	Safety Input	Bus	Interfaces-Bus A(+)/B(-)
QSSD	Safety Output	La	Emitted Light disengageable
Signal	Signal Output	Mag	Magnet activation
Bl_D+/-	Ethernet Gigabit bidirect. data line (A-D)	RES	Input confirmation
ENo RS422	Encoder 0-pulse 0/0 (TTL)	EDM	Contactor Monitoring
		ENARs422	Encoder A/Ā (TTL)
		ENBRs422	Encoder B/B̄ (TTL)
		ENa	Encoder A
		ENb	Encoder B
		AMIN	Digital output MIN
		AMAX	Digital output MAX
		Aok	Digital output OK
		SY In	Synchronization In
		SY OUT	Synchronization OUT
		Out	Brightness output
		M	Maintenance
		rsv	Reserved
		Wire Colors according to DIN IEC 60757	
		BK	Black
		BN	Brown
		RD	Red
		OG	Orange
		YE	Yellow
		GN	Green
		BU	Blue
		VT	Violet
		GY	Grey
		WH	White
		PK	Pink
		GNYE	Green/Yellow

Table 1

Working Distance	0,2 m	0,5 m	5 m
Light Spot Diameter	17 mm	35 mm	330 mm

Feasible reflector distance

Reflector type, mounting distance

RQ100BA	0,01...5 m	ZRAE02B01	0,01...2,2 m
RE18040BA	0,01...4,5 m	ZRDS01R01	0,05...0,8 m
RQ84BA	0,01...4,5 m	ZRME01B01	0,01...0,5 m
RR84BA	0,01...4,5 m	ZRME03B01	0,01...2,5 m
RE9538BA	0,01...2,2 m	ZRMR02K01	0,01...0,7 m
RE6151BM	0,01...4,3 m	ZRMS02_01	0,01...1,1 m
RR50_A	0,01...3,5 m	RF505	0,05...1,5 m
RE6040BA	0,01...4 m	RF255	0,05...1,1 m
RE8222BA	0,01...2,6 m	RF508	0,05...1,5 m
RR34_M	0,01...2,5 m	RF258	0,05...1,1 m
RE3220BM	0,01...1,5 m	RF4050	0,05...1 m
RE6210BM	0,01...1 m	ZRAF07K01	0,05...1,1 m
RR25_M	0,01...1,3 m	ZRAF08K01	0,05...1,5 m
RR25KP	0,04...0,8 m	ZRDF03K01	0,04...3,4 m
RR21_M	0,01...1,1 m	ZRDF10K01	0,04...4,5 m

