

Operating Instructions

S1NS002; S1NE002

Safety Through-Beam Sensor



EN



Table of Contents

| | | |
|----------|---|-----------|
| 1 | General | 3 |
| 1.1 | Information Concerning these Instructions..... | 3 |
| 1.2 | Explanation of Symbols..... | 3 |
| 1.3 | Limitation of Liability..... | 4 |
| 1.4 | Copyrights..... | 4 |
| 2 | For Your Safety | 5 |
| 2.1 | Use for Intended Purpose..... | 5 |
| 2.2 | Use for Other than the Intended Purpose..... | 5 |
| 2.3 | Personnel Qualifications..... | 5 |
| 2.4 | Modification of Products..... | 6 |
| 2.5 | General Safety Precautions | 6 |
| 2.6 | Approvals and Protection Class | 6 |
| 3 | Technical Data | 7 |
| 3.1 | General Data | 7 |
| 3.2 | Housing Dimensions..... | 8 |
| 3.3 | Control Panel..... | 9 |
| 3.4 | Complementary Products | 9 |
| 3.5 | Deflection mirror | 9 |
| 3.6 | Scope of delivery..... | 9 |
| 4 | Installation and Electrical Connection | 10 |
| 4.1 | Installation | 10 |
| 4.2 | Electrical Connection | 12 |
| 4.3 | Diagnosis | 12 |
| 5 | Settings | 14 |
| 5.1 | Inspection Instructions | 14 |
| 6 | Maintenance Instructions | 15 |
| 7 | Proper Disposal | 16 |
| 8 | Declarations of Conformity | 17 |

1 General

1.1 Information Concerning these Instructions

- These instructions make it possible to use the product safely and efficiently.
- These instructions are an integral part of the product and must be kept on hand for the entire duration of its service life.
- Local accident prevention regulations and national work safety regulations must be complied with as well.
- The product is subject to further technical development, and thus the information contained in these operating instructions may also be subject to change. The current version can be found at www.wenglor.com in the product's separate download area.



INFORMATION

The operating instructions must be read carefully before using the product and must be kept on hand for later reference.

1.2 Explanation of Symbols

- Safety precautions and warnings are emphasized by means of symbols and signal words.
- Safe use of the product is only possible if these safety precautions and warnings are adhered to.

The safety precautions and warnings are laid out in accordance with the following principle:

SIGNAL WORD

Type and source of danger!

Possible consequences in the event that the hazard is disregarded.

→ Measures for averting the hazard.

The meanings of the signal words, as well as the scope of the associated hazards, are listed below:



! DANGER

This signal word indicates a hazard with a high degree of risk which, if not avoided, results in death or severe injury.



! WARNING

This signal word indicates a hazard with a medium degree of risk which, if not avoided, may result in death or severe injury.



! CAUTION

This signal word indicates a hazard with a low degree of risk which, if not avoided, may result in minor or moderate injury.



NOTICE

This signal word draws attention to a potentially hazardous situation which, if not avoided, may result in property damage.



INFORMATION

Information draws attention to useful tips and suggestions, as well as information on efficient, error-free use.

1.3 Limitation of Liability

- The product has been developed in consideration of the current state-of-the-art technology, as well as applicable standards and guidelines. Subject to change without notice.
- A valid declaration of conformity can be accessed at www.wenglor.com in the product's separate download area.
- wenglor sensoric elektronische Geräte GmbH (hereinafter referred to as "wenglor") excludes all liability in the event of:
 - Non-compliance with the instructions
 - Use of the product for purposes other than those intended.
 - Use by untrained personnel.
 - Use of unapproved spare parts.
 - Unapproved modification of products.
- These operating instructions do not include any guarantees from wenglor with regard to the described procedures or specific product characteristics.
- wenglor assumes no liability for printing errors or other inaccuracies contained in these operating instructions unless wenglor was verifiably aware of such errors at the point in time at which the operating instructions were prepared.

1.4 Copyrights

- The contents of these instructions are protected by copyright law.
- All rights are reserved by wenglor.
- Commercial reproduction or any other commercial use of the provided content and information, in particular graphics and images, is not permitted without previous written consent from wenglor.

2 For Your Safety

2.1 Use for Intended Purpose

Safety through-beam sensors

The safety through-beam sensors protect areas in hazardous industrial environments. They have visible red light, a large aperture angle and a test input. TÜV-certified through-beam sensors can be used with a suitable analysis module up to performance level c in accordance with DIN EN ISO 13849-1.

This Product Can Be Used in the Following Industry Sectors:

- Special-purpose mechanical engineering
- Heavy mechanical engineering
- Logistics
- Automotive industry
- Food industry
- Packaging industry
- Pharmaceuticals industry
- Plastics industry
- Woodworking industry
- Consumer goods industry
- Paper industry
- Electronics industry
- Glass industry
- Steel industry
- Aviation industry
- Chemicals industry
- Alternative energies
- Raw materials extraction

2.2 Use for Other than the Intended Purpose

- The product is not suitable for use in potentially explosive atmospheres.
- The product may be used only with accessories supplied or approved by wenglor, or in combination with approved products. A list of approved accessories and combination products can be found at www.wenglor.com on the product detail page.
- The product is not suitable for use in outdoor weather.



DANGER

Risk of personal injury or property damage in case of use for other than the intended purpose!

Use for other than the intended purpose may lead to hazardous situations.

→ Observe instructions regarding use for intended purpose.

2.3 Personnel Qualifications

- Suitable technical training is a prerequisite.
- In-house electronics training is required.
- Trained personnel who use the product must have (permanent) access to the operating instructions.



DANGER

Risk of personal injury or property damage in case of incorrect initial start-up and maintenance!

Personal injury and damage to equipment may occur.

→ Adequate training and qualification of personnel

2.4 Modification of Products



DANGER

Risk of personal injury or property damage if the product is modified!

Personal injury and damage to equipment may occur. Noncompliance may result in loss of the CE and/or UKCA mark and voiding of the warranty.

→ Modification of the product is not permitted

2.5 General Safety Precautions



INFORMATION

These instructions are an integral part of the product and must be kept on hand for the entire duration of its service life.

In the event of possible changes, the current version of the operating instructions can be found at www.wenglor.com in the product's separate download area.

Read the operating instructions carefully before using the product.

Protect the sensor against contamination and mechanical influences.

2.6 Approvals and Protection Class

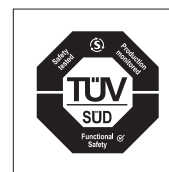
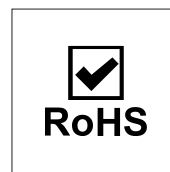

3 Technical Data

3.1 General Data



NOTICE

These sensors are suitable for safety applications when used with the SS2-00VA000R2 or SS2-00VA000R4 individual light barrier control unit. The performance level must be determined in accordance with EN ISO 13849-1 only in conjunction with the SS2-00VA000R2 or SS2-00VA000R4 individual light barrier control unit.

| Technical Data | emitter S1NS002 | receiver S1NE002 |
|---|---|---|
| Optical Data | | |
| range | 0,25 ... 25 m | 0.25 ... 25 m |
| light source | red light | red light |
| wavelength | 660 nm | 660 nm |
| Permissible ambient light: | | |
| Halogen lamp | | 10,000 lux |
| Sunlight | | 10,000 lux |
| Energy-saving light | | 1,500 lux |
| aperture angle | ± 5 ° | ± 5 ° |
| Electrical Specifications | | |
| sensor type | emitter | receiver |
| supply voltage | 19,2 ... 28,8 V DC (SELV, PELV power supply), must be able to bridge a 20 ms power failure (EN 60204-1) | 19.2 ... 28.8 V DC (SELV, PELV power supply), must be able to bridge a 20 ms power failure (EN 60204-1) |
| Fuse protection for supply voltage, inputs | max. 2 A | max. 2 A |
| Current consumption (U _b = 24 V) | < 20 mA | < 20 mA |
| temperature range | -30 ... 60 °C | -30 ... 60 °C |
| storage temperature | -30 ... 70 °C | -30 ... 70 °C |
| Humidity | max. 95%, non-condensing | Max. 95%, non-condensing |
| Voltage drop at switching output | | < 2 V |
| Switching current, PNP switching output | | 100 mA |
| Residual current at switching output | | < 50 µA |
| Short-circuit proof | | Yes |
| overload-proof | | yes |
| reverse polarity protected | Yes | Yes |
| protection class | III | III |
| Mechanical Specifications | | |
| housing material | Plastic, ABS | Plastic, ABS |
| degree of protection | IP65/IP67 | IP65/IP67 |
| connection type | M12 × 1; 4-pin | M12 × 1; 4-pin |
| Max. cable length | 50 m | 50 m |
| Safety technology data | | |
| ESPE Type (EN 61496) | 2* | 2* |
| Safety category (EN ISO 13849-1) | 2* | 2* |

| Technical Data | emitter S1NS002 | receiver S1NE002 |
|------------------------------------|---|---------------------|
| Performance Level (EN ISO 13849-1) | PL c* | PL c* |
| PFHD | 3,16 × E-7 1/h* | |
| MTTFd (EN ISO 13849-1) | 381 a | |
| Mission Time TM (EN ISO 13849-1) | 20 a | 20 a |
| Test interval | See operating instructions SS2-00VA000R2 or SS2-00VA000R4 | |
| Test rate | See operating instructions SS2-00VA000R2 or SS2-00VA000R4 | |

* in combination with SS2-00VA000R2 or SS2-00VA000R4. Additional operating instructions:

- The light barriers may only be used as access protection in accordance with EN ISO 13855. Use as finger and hand protection is not permitted. If it is possible for persons to remain in the danger zone, a restart inhibit must be used. The acknowledgment must come from outside the danger zone.
- If other light beams occur in an application (e.g. infrared controllers, emission due to welding sparks, powerful fluorescent lamps or the effects of strobe light), additional measures may be necessary in order to ensure that the ESPE does not fail in a dangerous fashion.
- Powerful fluorescent lamps must not be pointed directly towards the receiver's lens. The receiver might otherwise fail in a hazardous manner.

3.2 Housing Dimensions

Emitters

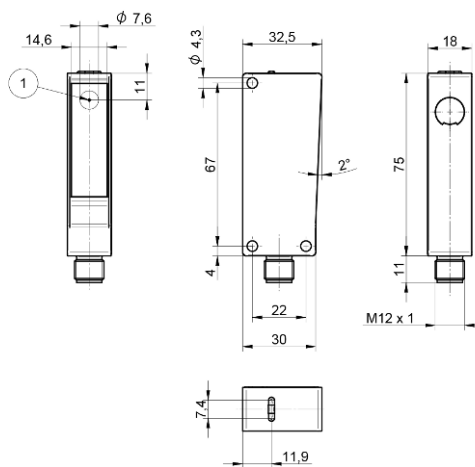

① = emitter diode

M4 screw = 0.5 Nm

Dimensions in mm (1 mm = 0.03937 inch)

Receivers

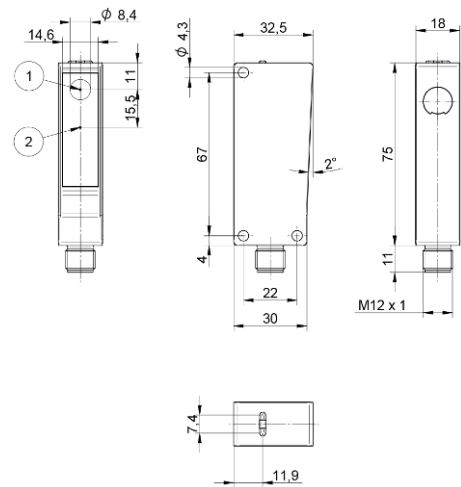

① = receiver diode

② = Alignment tool/switching status indicator

3.3 Control Panel

Emitters

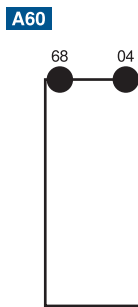

Receivers



04 = function indicator

30 = switching status indicator / contamination warning

68 = power LED

3.4 Complementary Products

wenglor offers you the right connection and mounting technology as well as other accessories for your product. You can find this at www.wenglor.com on the product details page at the bottom.

3.5 Deflection mirror

Using the Z2UG001 deflection mirror significantly expands the system's range of applications. With the Z2UG001 deflection mirror, a hazard zone can be protected from multiple sides using just one pair of safety through-beam sensors.



NOTICE

The range of the ESPE is reduced by approximately 10% per mirror.

3.6 Scope of delivery

- Sensor

4 Installation and Electrical Connection

4.1 Installation

- Protect the product from contamination during installation.
- The relevant electrical and mechanical regulations, standards and safety rules must be observed.
- Protect the product from mechanical impact.
- Ensure that the product is mounted mechanically secure.
- Torques must be observed (see chapter Technical data [► 7]).



NOTICE

The operating instructions for the SS2-00VA000R2 or SS2-00VA000R4 individual light barrier control unit must also be followed.

The barriers must be installed so that access to the hazardous area is only possible through the beam of light from the barriers. It must not be possible to reach around from the side, over or under. If necessary, this must be ensured by additional mechanical protection. The mounting height and the distance to the hazardous movement are regulated in EN ISO 13855 and are explained below.

Safety clearance

Calculation of the safety clearance is based on the EN ISO 13855 standard. However, if any special directives and standards apply to the respective machine, these must be taken into consideration as well.

$$S = K \times T + C$$

S = safety clearance [mm]

K = approach speed = 1600 [mm/s]

T = total response time (t1 + t2) [s]

t1 = response time safety through-beam sensor [s] + response time safety analysis module [s]

t2 = machine over-travel time [s]

C = margin [mm], depending on the number of safety through-beam sensors (see table below)

| Number of safety through-beam sensors | 1 | 2 | 3 | 4 |
|---------------------------------------|------|-----|------|------|
| Height above reference level [mm] | 750 | 400 | 300 | 300 |
| | | 900 | 700 | 600 |
| | | | 1100 | 900 |
| | | | | 1200 |
| Margin C [mm] | 1200 | 850 | 850 | 850 |



NOTICE

The response time t1 (response time light barrier + response time safety control) can be found in the operating instructions of the SS2-00VA000R2 individual light barrier control unit.

Access protection with S1N

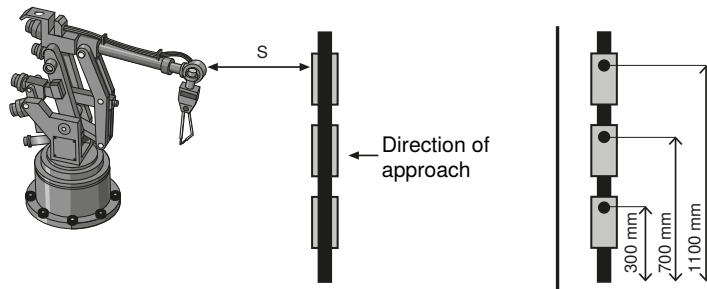

Minimum Clearance to Reflective Surfaces

In order to prevent bleed-over reflection, a minimum clearance between reflective objects and the optical axis must be maintained.

Minimum clearance = $\tan 5^\circ \times$ (clearance between emitter and receiver)

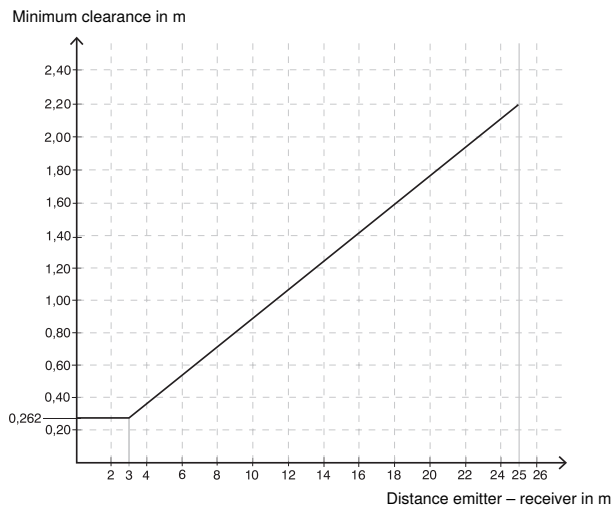

Avoidance of mutual interference

To prevent mutual influence of the safety through-beam sensors:

- Only one emitter (receiver) may be within the aperture angle of the receiver (emitter).
- The sensor pairs must be aligned anti-parallel for multi-beam safeguarding.



NOTICE

Risk of property damage in case of improper installation!

The product may be damaged!

→ Comply with installation instructions.



CAUTION

Risk of personal injury or property damage during installation!

Personal injury and damage to the product may occur.

→ Ensure a safe installation environment.

4.2 Electrical Connection

- Wire the sensor in accordance with the connection diagram.
- Switch on the supply voltage (see section Technical Data [► 7])



DANGER

Risk of personal injury or property damage due to electric current.

Voltage-conducting parts may cause personal injury or damage to equipment.

→ The electric device may be connected by appropriately qualified personnel only.

Emitters

769

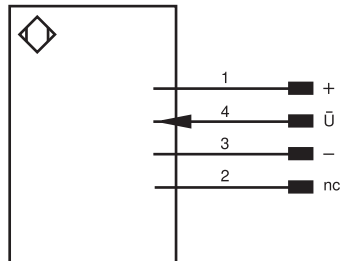

Receivers

1021

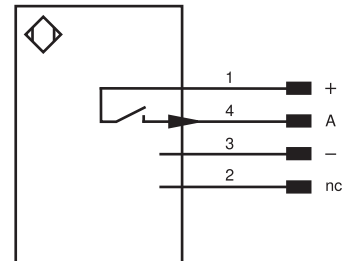





- + Supply voltage +
- 0 V supply power
- A Switching output 2 normally open (NO)
- nc not connected
- U Test input inverted







4.3 Diagnosis





See section Control Panel [► 9].

Emitters

| Indicator | Status LED | Meaning |
|--------------------|---|----------------------------|
| Power LED |  | Sensor ready for operation |
| |  | No voltage supply |
| Function indicator |  | High level at test input |
| |  | Low level at test input |

Receivers

| Indicator | Status LED | Meaning |
|----------------------------|---|--|
| Power LED |  | Sensor ready for operation |
| |  | No voltage supply |
| |  | Short circuit/overload on output |
| Switching status indicator |  | Output on |
| |  | Output off |
| |  | Contamination – carefully clean the optic cover with a cloth Aging of the emitter diode – replace sensor Unsafe working range – reduce distance between emitter and receiver |

-  = not lit
-  /  = permanently lit
-  = flashes continuously (4 Hz)

5 Settings

- Mount and align the emitter and receiver opposite each other until the output of the receiver switches.
- Move the object into the light barrier and check for correct functioning.

5.1 Inspection Instructions

The inspections described below serve to confirm compliance with specified safety requirements set forth in national/international regulations, in particular the safety requirements included in the machinery directive and the directive concerning safety and health requirements for the use of work equipment. The inspections also serve to detect influences which effect the device's protective action, as well as any other unusual ambient influences.

Inspection Prior to Initial Start-Up

Inspection of ESPE in accordance with local ordinances.

- Inspection for correct attachment of the safety device, correct electrical connection to the controller and effectiveness in all of the machine's operating modes.
- The same inspection requirements apply if the machine in question has been shut down for a lengthy period of time and after significant modifications or repairs, if these might influence safety in any way.
- Observe regulations regarding the training of operating personnel by qualified persons before operators begin work. The company which operates the machine is responsible for training.
- Check the protection function (see section of the same name).

Regular Inspection (at least Annually)

Regular testing must be completed in accordance with local ordinances. They serve the purpose of detecting changes to (e.g. over-travel time) or manipulation of the machine and the safety devices.

- Regular inspections must be conducted by a person who has been authorized and engaged to do so by the company which operates the machine. The frequency (e.g. daily, at shift changes, etc.) must be determined based on the risk assessment for the application.
- The effectiveness of the ESPE must be tested with supply power to the ESPE switched on, and supply power to the hazardous motion of the machine switched off.
- Check the protection function (see section of the same name).

Checking the Protection Function

The protection function of the ESPE must be tested by reaching into the light beam with a test rod (diameter 30 mm).

The test rod must be moved through the light beam. Each beam must be tested individually. As long as the light beam is interrupted, it must not be possible to initiate any dangerous movement.

If any impairment of the device's safety function is detected during regular testing or during operation, all work at the respective machine must be immediately stopped!

6 Maintenance Instructions



NOTICE

This wenglor product is maintenance-free.

Cleaning and inspection of the plug connections at regular intervals are advisable.

Do not clean the product with solvents or cleaning agents that could damage the product.

The product must be protected against contamination during initial start-up.

7 Proper Disposal

wenglor sensoric GmbH does not accept the return of unusable or irreparable products. Respectively valid national waste disposal regulations apply to product disposal.

8 Declarations of Conformity

The products have been developed, designed and manufactured in accordance with directives 2006/42/EC and 2014/30/EC. The following international standards and specifications apply:

EN IEC 61496-1:2020 (Type 2)

EN IEC 61496-2:2020 (Type 2)

EN ISO 13849-1:2023 (Cat. 2, PL c)

EN IEC 61000-6-4:2019

Declarations of conformity can be found on our website at www.wenglor.com in the product's separate download area.

wenglor sensoric ltd.
Unit 2, Beechwood
Cherry Hall Road
Kettering Business Park
Kettering, Northants NN14 1UE
Tel: +44 1536 313 580
info.uk@wenglor.com