

Operating Instructions

EP8C001

IO-Link Master EtherCAT



EN



Table of Contents

1	General	4
1.1	Information Concerning these Instructions	4
1.2	Explanation of Symbols	4
1.3	Limitation of Liability	5
1.4	Copyrights	5
2	For Your Safety	6
2.1	General Safety Instructions	6
2.2	Use for Intended Purpose	7
3	Description	8
3.1	Device	8
3.1.1	Device Configuration	9
3.1.2	Pin Assignments	10
3.1.3	Display Units	11
4	Technical Data	12
4.1	Electrical data	12
4.2	Ambient Conditions	15
4.3	Protection	16
4.4	Mechanical Data	16
4.5	Conformity, Approvals	16
4.6	Used IP Ports	17
5	Installation	18
5.1	Prerequisites	18
5.2	Dimensions	18
5.3	Mounting Clearance	19
5.4	Installation of the Unit	19
5.5	Functional Earth	21
5.6	Addressing Cover	21
6	Installation	22
6.1	Installing the Unit Electrically	22
6.1.1	Adjusting the Rotary Switch	23
6.1.2	Sensors and Actuators	25
6.1.3	Power Supply	26
6.1.4	EtherCAT Communication	27
6.2	Ensure Tightness (IP67)	27
7	Initial Start-Up	28
7.1	EtherCAT	28
7.1.1	Integrate Device into Beckhoff TwinCAT V3	28
7.1.2	Add a Device	29
7.1.3	Explicit Device ID	30
7.1.4	AoE	33
7.1.5	EoE	34
7.1.6	Firmware Update via FoE	35
8	Configuration/Setting	38
8.1	Configure IO-Link Master	38
8.2	Configure IO-Link Master Parameters	39
8.3	General EtherCAT objects	42

8.4	Bitmapping and Process Data of the Device	47
8.5	Distributed Clocks (DC).....	50
8.6	Industrial Internet of Things (IIoT).....	50
8.6.1	JSON	50
8.6.2	MQTT	53
8.6.3	OPC UA	54
8.7	Object Directory	68
8.7.1	Setting the IO-Link Master	68
8.7.2	Setting IO-Link Ports	69
8.7.3	Device Reset.....	70
9	Operation.....	71
9.1	LED Display	71
9.1.1	* Flashing Behavior:	71
9.1.2	LED Display for Inputs and Outputs	71
9.1.3	LED Display RUN_ERR.....	73
9.1.4	LED Display L/A1/LA2.....	74
9.1.5	LED Display Status	74
9.1.6	LED Display POWER US and UA.....	75
9.2	EtherCAT Diagnostic Messages	75
10	Web Server	78
10.1	Start Web Server	78
10.2	Access and Login	78
10.3	Start Screen	80
10.4	Menu Bar.....	80
10.4.1	STATUS Menu.....	81
10.4.2	PARAMETERS Menu	83
10.4.3	DIAGNOSTICS	84
10.4.4	IODD CATALOG Menu.....	85
10.4.5	MAINTENANCE Menu	85
10.5	IO-Link Master Port.....	86
10.5.1	STATUS Menu.....	86
10.5.2	INFORMATION Menu	87
10.5.3	CONFIGURATION Menu.....	88
10.5.4	IO-LINK PARAMETERS Menu	89
10.5.5	PROCESS DATA Menu	90
10.6	Digital IO Channels / IO Overview	90
10.6.1	Input Data	90
10.6.2	Output Data	91
10.7	Settings / Maintenance.....	92
10.7.1	MAINTENANCE INFORMATION Menu.....	92
10.7.2	FIRMWARE Menu	92
10.7.3	FACTORY RESET Menu	93
10.8	User Management.....	93
11	Maintenance Instructions	95
12	Proper Disposal	96
13	Declarations of Conformity.....	97

1 General

1.1 Information Concerning these Instructions

- These instructions make it possible to use the product safely and efficiently.
- These instructions are an integral part of the product and must be kept on hand for the entire duration of its service life.
- Local accident prevention regulations and national work safety regulations must be complied with as well.
- The product is subject to further technical development, and thus the information contained in these operating instructions may also be subject to change. The current version can be found at www.wenglor.com in the product's separate download area.



INFORMATION

The operating instructions must be read carefully before using the product and must be kept on hand for later reference.

1.2 Explanation of Symbols

- Safety precautions and warnings are emphasized by means of symbols and signal words.
- Safe use of the product is only possible if these safety precautions and warnings are adhered to.

The safety precautions and warnings are laid out in accordance with the following principle:

SIGNAL WORD

Type and source of danger!

Possible consequences in the event that the hazard is disregarded.

→ Measures for averting the hazard.

The meanings of the signal words, as well as the scope of the associated hazards, are listed below:



DANGER

This signal word indicates a hazard with a high degree of risk which, if not avoided, results in death or severe injury.



WARNING

This signal word indicates a hazard with a medium degree of risk which, if not avoided, may result in death or severe injury.



CAUTION

This signal word indicates a hazard with a low degree of risk which, if not avoided, may result in minor or moderate injury.



NOTICE

This signal word draws attention to a potentially hazardous situation which, if not avoided, may result in property damage.



INFORMATION

Information draws attention to useful tips and suggestions, as well as information on efficient, error-free use.

1.3 Limitation of Liability

- The product has been developed in consideration of the current state-of-the-art technology, as well as applicable standards and guidelines. Subject to change without notice.
- A valid declaration of conformity can be accessed at www.wenglor.com in the product's separate download area.
- wenglor sensoric elektronische Geräte GmbH (hereinafter referred to as "wenglor") excludes all liability in the event of:
 - Non-compliance with the instructions
 - Use of the product for purposes other than those intended.
 - Use by untrained personnel.
 - Use of unapproved spare parts.
 - Unapproved modification of products.
- These operating instructions do not include any guarantees from wenglor with regard to the described procedures or specific product characteristics.
- wenglor assumes no liability for printing errors or other inaccuracies contained in these operating instructions unless wenglor was verifiably aware of such errors at the point in time at which the operating instructions were prepared.

1.4 Copyrights

- The contents of these instructions are protected by copyright law.
- All rights are reserved by wenglor.
- Commercial reproduction or any other commercial use of the provided content and information, in particular graphics and images, is not permitted without previous written consent from wenglor.

2 For Your Safety

2.1 General Safety Instructions



DANGER

High electrical voltage in the machine/system.

Death or serious injury from electric shock.

→ Comply with the five safety rules of electrical engineering when working on the machine/equipment.

Protection of Persons and Property

According to DIN VDE 0105-100 – Operation of electrical systems – Part 100: General specifications

The Five Safety Rules

Protect against high voltage

1. Enable.
2. Secure against being switched on again.
3. Check that there is no voltage at all poles.
4. Ground and short-circuit.
5. Cover or cordon off adjacent live parts.

Specialist Personnel

Only qualified and safety-technically instructed personnel may install, commission and operate the device.

You are qualified if you meet the following conditions:

- You have suitable electrical training.
- You have been instructed by the machine operator in the operation of the system and the applicable safety regulations.
- You have access to the operating instructions and the manual.
- You are familiar with the safety standards of automation technology.
- You are familiar with the basic and technical standards applicable to the specific application.

Use of the Device

Observe all safety and accident prevention regulations during project planning, installation, initial startup, operation and testing of the device.

When using aggressive media, check the material resistance.



INFORMATION

Only qualified personnel from wenglor Sensoric GmbH may perform interventions in the hardware and software, with the exception of firmware updates.



INFORMATION

Only use a power supply unit that allows max. 60 V DC or 25 V AC in the event of a fault. It must comply with SELV or PELV.

Safety Measures of the Machine Operator

- Follow the instructions in this manual.
- Observe the test specifications in the operating instructions of all connected components.

2.2 Use for Intended Purpose

The EP8 family of devices are decentralized devices. They can be used in harsh industrial environments up to IP67 degree of protection.

The intended operation of the devices and the degree of protection IP67 is only guaranteed if open plugs and sockets are closed with locking screws.

Intended use also includes EMC-compliant electrical installation. The device is intended for use in industrial environments. When used in residential or mixed-use areas, radio interference may occur.

When using the device in residential or mixed-use areas, observe the applicable standards.

Foreseeable Misuse

- Do not modify the device structurally, technically or electrically.
- Do not use the device outside the areas described in this manual, the technical data and the operating instructions.
- Do not use the device as a safety-related device. It does not comply with the relevant standards. Safety functions of the system are not guaranteed!
- Switching the device outputs to the off state may not be used for safety requirements for the respective machine or system!
- Do not use the device outdoors or for permanent operation in liquids.
- Do not clean the device with a high-pressure cleaner.
- Do not use the device as a climbing aid.

Warranty and liability claims are forfeited if:

- the device is not used as intended,
- damage is due to failure to observe the manual and operating instructions,
- the personnel was/is not competent.

3 Description

3.1 Device

EP8C001

The IO-Link Master EP8C001 is a compact EtherCAT device in a plastic housing with an IP67 degree of protection.

Connection

2xM12 slots (D-coded) are available for connection to the EtherCAT.

Supply Power

The supply power is fed and looped via M12 Power (L-coded 5-pin).

IO-Link

Furthermore, the device has 8xM12 IO-Link master slots (A-coded). The IO-Link masters (pin 4 C/Q) can be parameterized independently of each other and can be used either in IO-Link or in SIO mode (DI, DO). Additional digital inputs and outputs as well as a permanent 24 V supply are available for each slot (pin 2 I/Q).

Characteristics

- EtherCAT: AoE, EoE, FoE
- IP67 degree of protection
- Vibration shock tested

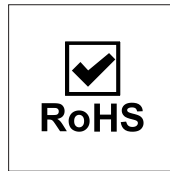
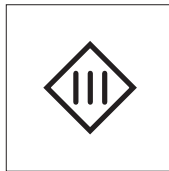

3.1.1 Device Configuration

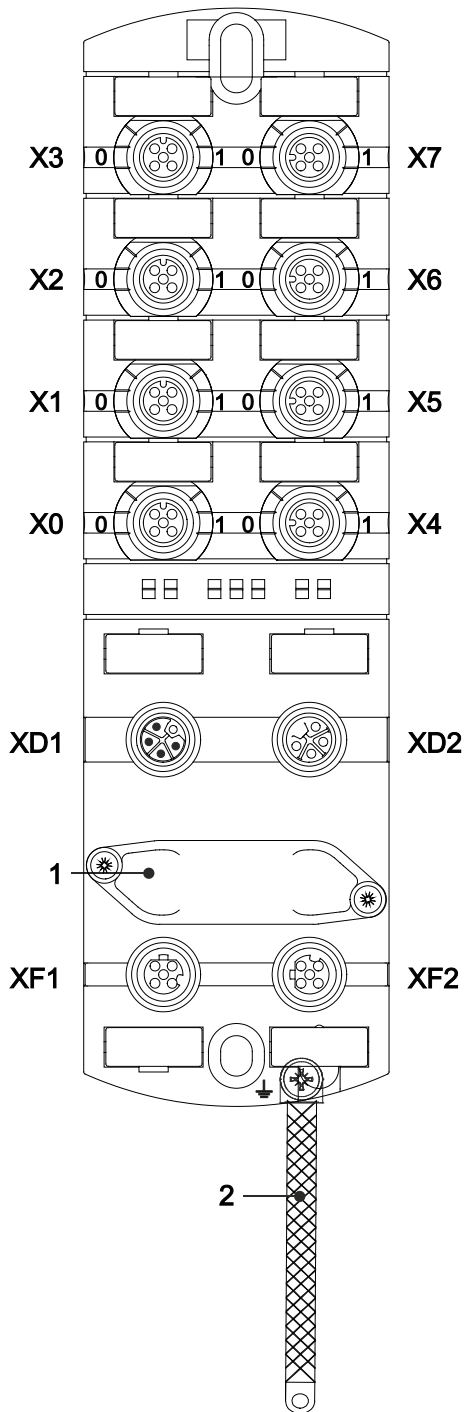

X0 ... X7 Digital inputs and outputs or IO-Link
M12 A-coded

0 Channel corresponds to Pin 4

1 Channel corresponds to Pin 2

Examples:

Channel 02 = Pin 4 Socket X2

Channel 16 = Pin 2 Socket X6

XD1 Voltage supply POWER IN,
M12 L-coded, 5-pin

XD2 Voltage supply POWER OUT,
M12 L-coded 5-pin

1 Rotary switch

XF1 EtherCAT port 1, M12 D-coded

XF2 EtherCAT port 2, M12 D-coded

2 Ground strap for functional earth

3.1.2 Pin Assignments

M12 Socket, A-Coded

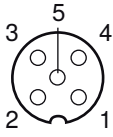
X0...X7		
	Pin 1	24 V DC
	Pin 2	DI/DO
	Pin 3	0 V
	Pin 4	DI/DO/IO-Link
	Pin 5	0 V

M12 Plug/Socket, L-Coded

POWER IN/OUT

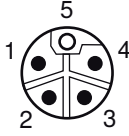
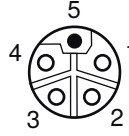
XD1		XD2	
	Pin 1	24 V DC	
	Pin 2	0 V	
	Pin 3	0 V	
	Pin 4	24 V DC	
	Pin 5	±	

M12 Socket, D-Coded

Port 1 / Port 2

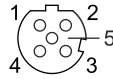
XF1 / XF2		
	Pin 1	TD +
	Pin 2	RD +
	Pin 3	TD -
	Pin 4	RD -
	Pin 5	Unused

3.1.3 Display Units

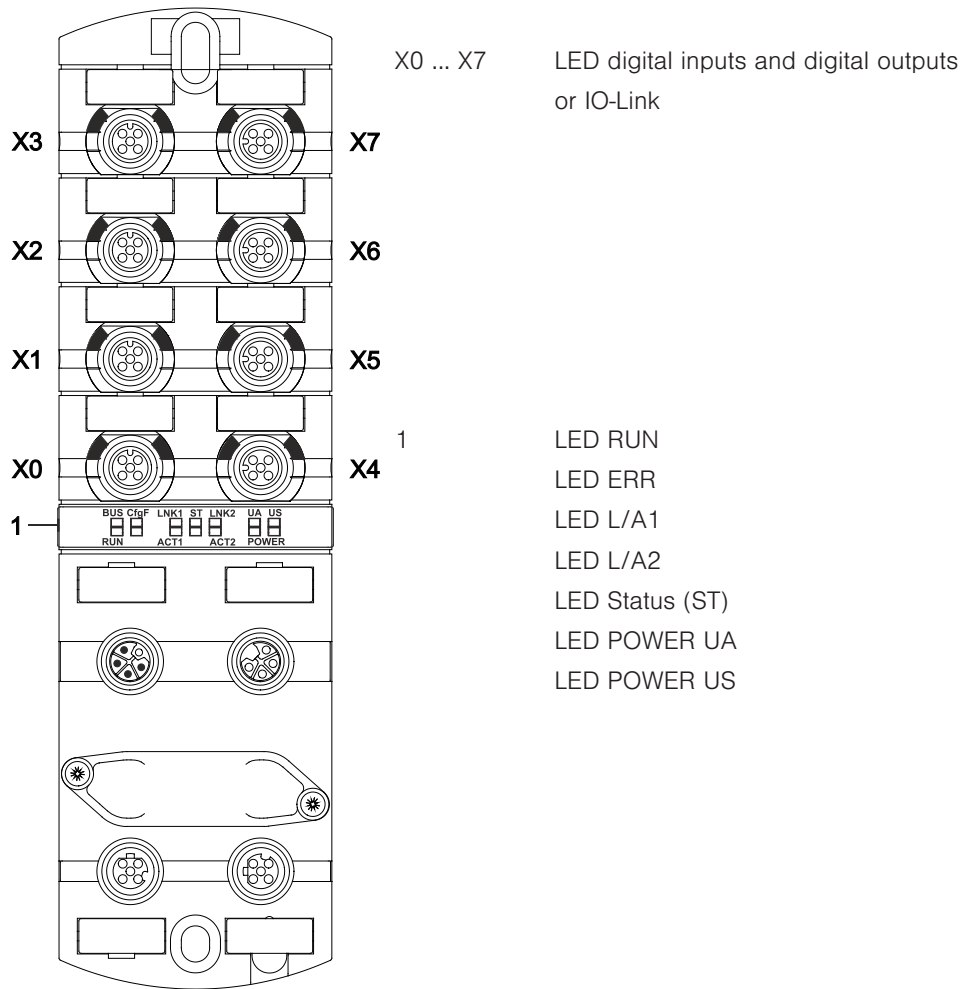

INFORMATION

For more information on the behavior of the LEDs, see section “LED Display [► 71]”.

4 Technical Data

4.1 Electrical data

Bus Data		
Bus protocol		EtherCAT
Connection		M12, 4-pin, D-coded
Transmission speed		100 Mbit/s
Specification		ETG.5001.6220 S
Supported protocol	ADS over EtherCAT	AoE
	CANopen over EtherCAT	CoE
	Ethernet over EtherCAT	EoE
	File access over EtherCAT	FoE
Diagnostics function	EtherCAT state machine	ESM
	Emergency messaging	EMCY
SYNC manager		4
FMMU		8

OPC UA Server		
OPC UA Server	According to "IO-Link Companion Specification"	Yes
Transport		UA TCP, UA Secure Conversation, UA Binary Encoding
Server profile		Micro embedded device
Protocol		OPC UA TCP
User access	Read access only	Anonymous
	Read and write access	Username/password
Number of sessions		2
Number of subscriptions per session		2
Number of "Monitored Items" per session		20
Minimum publication interval		100 ms
Maximum number of sessions/clients		5
Data coding		UA binary
Energy monitoring	Current and voltage	Yes
Temperature monitoring		Yes

MQTT client		
MQTT		Client
Client services		Publish
Protocols	Via TCP	MQTT
Topic size	Individually per MQTT publication	≤ 256 bytes
	and Common topic prefix of the associated MQTT connection	≤ 256 bytes

MQTT client		
Topics		- Printable UTF-8 string - ZERO-terminated - Multi-byte encoding (MBCS) - Payload: JSON
Will Topic		≤ 256 bytes
Quality of service		QoS 0, QoS 1 and QoS 2
IP standard		IPv4
Port	1883 (standard)	MQTT unencrypted
MQTT standard		V3.1.1
JSON, MQTT	JSON integration for IO-Link V1.0.0	Yes, via REST API and MQTT
Energy monitoring	Current and voltage	Yes
Temperature monitoring		Yes
Restriction		The service "Subscribe" not supported

Web server		
HTTP		HTTP/1.1
Port		80
Connections	Via TCP	≤8 simultaneous connections. A connection is being edited.
JavaScript		Required
HTTPS		Not supported

REST API		
Standard	According to "JSON Integration for IO-Link, Version 1.0.0, Mar 2020" https://io-link.com/share/Downloads/IO-Link_Integration/JSON_Integration_10222_V100_-Mar20.zip	Yes
Protocol		HTTP
User access	Read access only Read and write access	Anonymous Username/password
Authentication	According to RFC 7617	HTTP Basic Authentication
Supported endpoints		Refer to product manual

IO-Link		
Operating voltage IO-Link devices		24 V DC
Voltage range IO-Link devices		20...30V DC
Transmission speed		COM1 / COM2 / COM3
Standardized Master Interface (SMI)		See IO-Link specification
Transmission speed detection		Automatic

Supply Power		
Operating voltage US		24 V DC
Voltage range US		18...30 V DC
	When using IO-Link	20.3...30 V DC
Operating voltage UA		24 V DC
Voltage range UA		18...30 V DC
Sensor current US	≤ 40 °C (see derating)	≤ 16 A
Actuator current UA	≤ 40 °C (see derating)	≤ 16 A
Current consumption	In idle	≤ 0.18 A
Reverse polarity protection for US and UA		Yes
Reverse polarity protected		Yes
Connection		M12, 5-pin, L-coded
Cable cross section	Current per supply ≤12 A	≥ 1.5 mm ²
	Current per supply >12 A	≥ 2.5 mm ²

Input (DI)		
Sensor power supply	Per port, ≤40 °C (see derating)	≤2 A load Automatic start
Total current sensor supplies	≤ 40 °C (see derating)	≤10 A
Filter time		0 ... 15 ms + t _{cycle} , configurable
Delay time at signal change		2 ... 5 ms
Input characteristics	EN 61131-2	Type 1 + Type 3
Short-circuit protection sensor supply		MOSFET with current measurement
Connection		M12, 5-pin, A coded
Cable cross-section M12		≤ 0.75 mm ²
Cable Length		≤ 30 m
Total current	Per port	≤ 4 A

Output (DO)		
Output current DO (UA)	Per pin, ≤40°C (see derating)	≤ 2 A
Total current outputs	≤ 40 °C (see derating)	≤ 10 A
Switching frequency		≤50 Hz
Actuator short-circuit protection		MOSFET with current measurement
Connection		M12, 5-pin, A coded
Cable cross-section M12		≤ 0.75 mm ²
Cable Length		≤ 30 m
Total current	Per port	≤ 4 A

Derating

Sensor Current US/Actuator Current UA

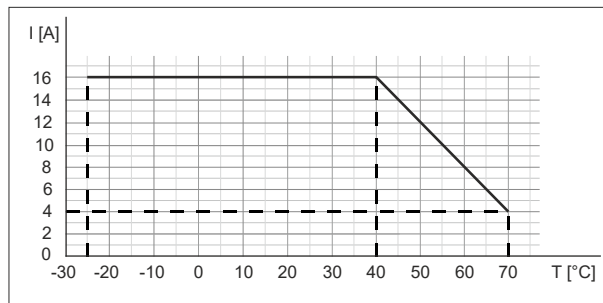

Derating Total Current Sensor Supplies/Total Current Outputs

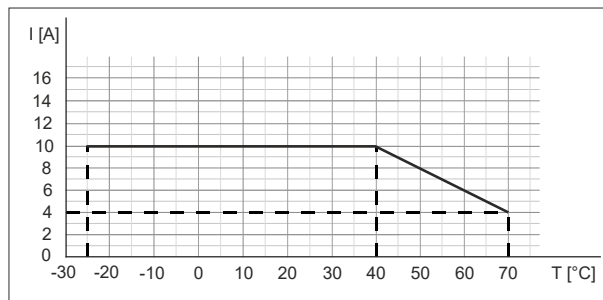

Derating Current per Sensor Supply/Output

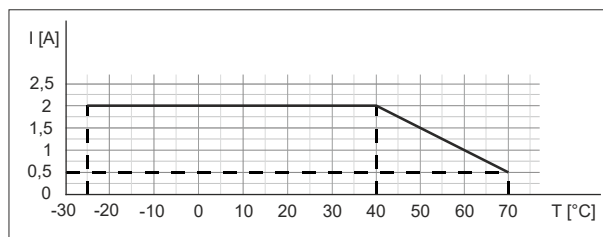

4.2 Ambient Conditions

Climatic Conditions		
Ambient temperature		-40 °C ... +70 °C
Storage temperature	Provide for acclimatization for initial start-up	-40 °C ... +85 °C
Transport temperature	Provide for acclimatization for initial start-up	-40 °C ... +85 °C
Relative humidity		≤ 95%
Installation altitude	Above normal height	≤ 3,000 m

Mechanical Characteristics		
Vibration testing	EN 60068 Part 2-6	10 ... 58 Hz, oscillation range 0.35 mm, 58 ... 150 Hz; 20 g
Shock test	EN 60068 Part 2-27	50 g, duration 11 ms

Electric Safety		
Degree of protection	EN 60529	IP67
Protection class	Using a SELV or PELV power supply	III
Pollution degree		2

EMC Interference Emission		
Radio interference field strength housing	EN 55016-2-3	Compliant

EMC Interference Immunity		
Electrostatic discharge (ESD)	EN 61000-4-2	Compliant
High frequency electrical fields	EN 61000-4-3	Compliant
Fast transients burst	EN 61000-4-4	Compliant
Surge voltages	EN 61000-4-5	Compliant
Conducted HF	EN 61000-4-6	Compliant
Voltage dips	EN 61000-4-11	Compliant

4.3 Protection

Equipment Protection		
Overvoltage protection		Yes
Overload protection device supply	To be ensured by load circuit monitoring	Yes
Reverse polarity protection device supply		Yes
Short-circuit protection sensor supply		Electronic
Short-circuit protection output		Electronic
Protective circuit input	Internal	Suppressor diode

4.4 Mechanical Data

Material Data		
Housing material		Plastic

Mounting Data		
Weight	Net	470 g
Dimensions	L × W × H	225.4 × 63 × 36 mm

4.5 Conformity, Approvals

Conformity, Approvals		
Product standard	EN 61131-2 Programmable logic controllers part 2	Compliant
CE	2014/30/EU 2011/65/EU	Compliant
UKCA		Compliant

Conformity, Approvals		
EMC	2014/30/EU	Compliant
REACH	No. 1907/2006	E201820
WEEE	2012/19/EU	Compliant
UL		E201820
RoHS	2011/65/EU & 2015/863	Exception 6c&7a
China RoHS	SJ/T 11364-2014	25 EPUP

Hazardous substance (有害物質)							
	Part Name 零件名稱	Lead (Pb) 鉛	Mercury (Hg) 汞	Cadmium (Cd) 鎘	Hexavalent Chromium (Cr (VI)) 六价铬	Polybrominated biphenyls (PBB) 多溴联苯	Polybrominated diphenyl ethers (PBDE) 多溴联苯醚
		Component part PCB ^{1 2} 组件部分 印刷电路板	X	0	0	0	0
	Connection Terminal / Screws / Housing ³ 接线端子 / 拧 / 外壳	X	0	0	0	0	0

O : Indicates that the content of the harmful substance in all homogeneous materials of the component part is below the limit defined in GB/T 26572.
O : 表明該有害物質在組成部分的所有均質材料的含量低於按GB/ T26572定義的限制。
X: Indicates that the content of the harmful substance in at least one homogeneous material of the component part exceeds the limit defined in GB/T 26572.
X: 表示該有害物質在組成部分中的至少一個均質材料的含量超過按GB / T26572定義的限制。

4.6 Used IP Ports



INFORMATION

There is no fixed or configurable port for the MQTT client. If MQTT client is activated, it is assigned to the next free port of the IP stack.

Port	
TCP port 80	Integrated web server
TCP port 4840	Integrated OPC UA server. Port can be re-configured at runtime: netPROXY Object "OPC UA Server - Component Configuration"

5 Installation

5.1 Prerequisites

Prerequisites for installation:

- Flat mounting surface for mechanically stress-free mounting.
- Provide suitable grounding.
- Suitable installation location with regard to vibration and shock load, temperature and humidity (see section 4 "Technical Data").
- Protected to prevent the connection cables from being torn off by personnel or equipment.

5.2 Dimensions

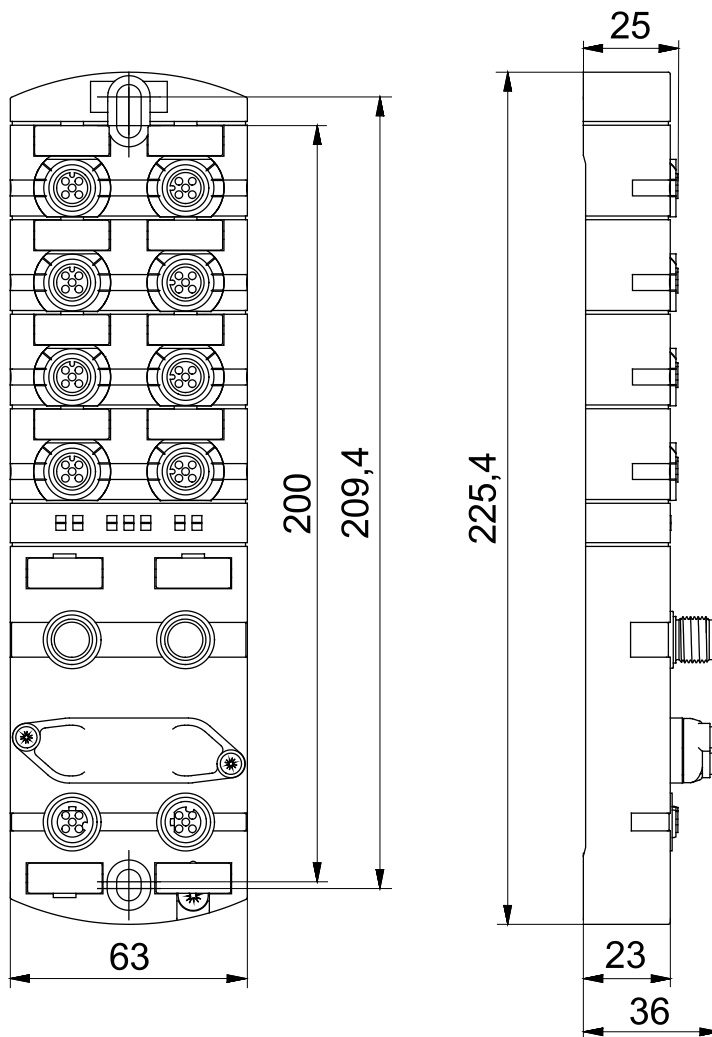

Dimensions in mm (1 mm = 0,03937 Inch)

5.3 Mounting Clearance

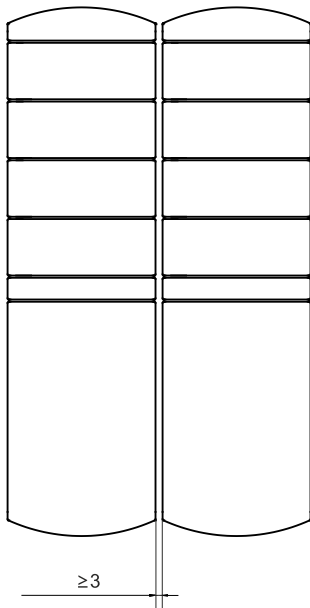

Distance in mm



INFORMATION

For proper installation and improved heat dissipation, we recommend maintaining a minimum distance of 3 mm when mounting the IO-Link Master.



INFORMATION

A minimum distance of 50 mm must be maintained when using angled plugs.

5.4 Installation of the Unit



NOTICE

Material damage due to incorrect installation.

The mounting screws and tightening torques depend on the subsurface of the installation site.

1. Use mounting screws according to the condition of the mounting surface.
2. Tighten the screws carefully. The specified tightening torques must be observed.



NOTICE

Material damage due to misuse.

Do not use the equipment as a climbing aid. Misuse may cause the devices to tear off or otherwise be damaged.

- Mount the devices in such a way that they cannot be used as climbing aids.

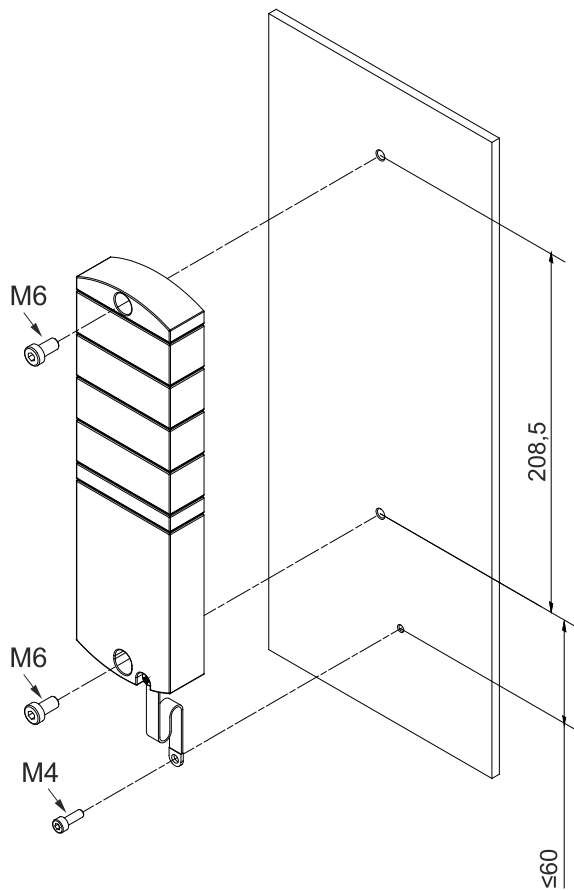

Secure the device. Dimensions in mm (similar to figure)

M6: 3 Nm torque

M4: 1.2 Nm torque

Mount the device in the specified order:

1. Slightly tighten the second M4 screw.
2. Align the housing.
3. Slightly tighten the bottom M4 screw.
4. Tighten the M4 screws according to the torque.
5. Ground the device: Fasten ground strap (Functional Earth ► 21]).



INFORMATION

The mounting screws and nuts are not included in the scope of delivery.

5.5 Functional Earth



INFORMATION

Note

Fasten the ground strap with a conductive screw.

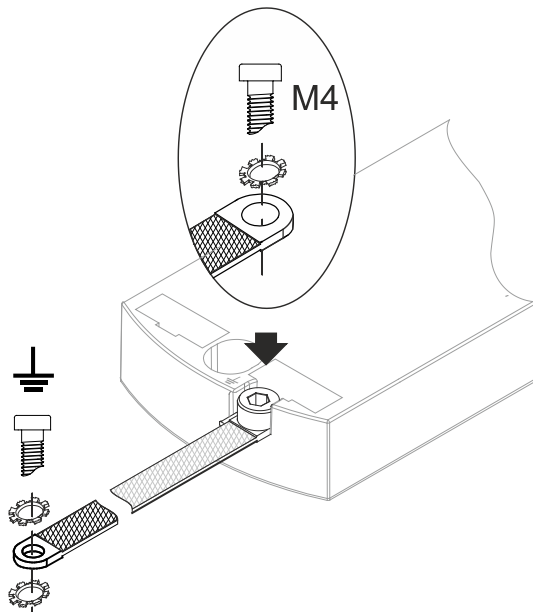

M4 tightening torque 1.2 Nm

5.6 Addressing Cover

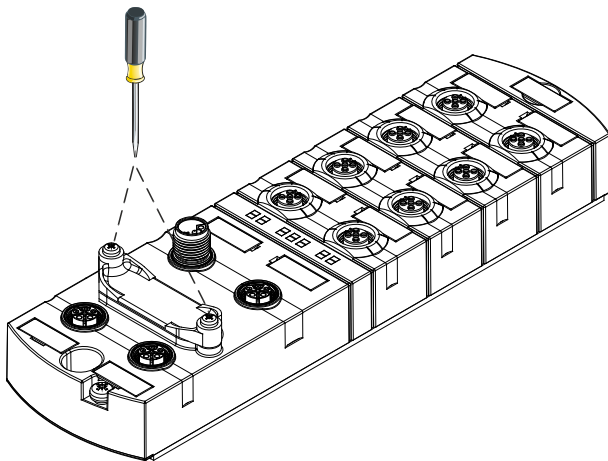

Attaching the addressing cover

M3 tightening torque 0.8 Nm



INFORMATION

Information on setting the rotary switches can be found in section [Adjusting the Rotary Switch](#) [► 23]

6 Installation

6.1 Installing the Unit Electrically



DANGER

High electrical voltage in the machine/system.

Death or serious injury from electric shock.

→ Comply with the five safety rules of electrical engineering when working on the machine/equipment.

Protection of Persons and Property



WARNING

Risk of fire due to short circuit.

Supply lines and/or devices damaged by a short circuit can overheat and cause fires!

→ Provide intelligent current monitoring or fuse. The fuse must be rated for max. 9 A.



CAUTION

Loss of function due to improper installation.

Failure to observe this may result in damage to property and personal injury.

→ Only install cables and accessories that comply with applicable safety and electromagnetic compatibility requirements and regulations, and if applicable correspond with any telecommunication terminal devices and their specifications.



CAUTION

Hot interface.

Slight bodily injury due to contact with the surface and damage to the equipment.

1. Wear suitable heat-resistant gloves.
2. Only use thermally suitable connection cables.



NOTICE

Damage to the machine/system due to improper switching on of the voltage sources.

When switching on the device with separate actuator and sensor, the function of the digital inputs and outputs is not guaranteed.

→ Always switch on the voltage sources in this order:

1. Switch on sensor voltage.
2. Switch on the actuator voltage.



INFORMATION

Only use a power supply unit that allows max. 60 V DC or 25 V AC in the event of a fault. It must comply with SELV or PELV.

6.1.1 Adjusting the Rotary Switch



INFORMATION

Each participant must have a clear and unique IP address in the network.

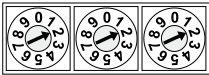
x 100 x 10 x 1 	Address range 1 ... 999 x1 rotary switch (one) x10 rotary switch (tens) x100 rotary switch (hundreds)
---	---

Position/Range	Web server	JSON	OPC UA	MQTT	Description	
0	_**	_**	_**	_**	Normal operation	EtherCAT ID can be assigned via Mailbox (Explicit Device ID).
1 ... 99	_**	_**	_**	_**	EtherCAT ID	EtherCAT ID is set to the rotary switch value.
100 ... 910	_**	_**	_**	_**	Reserved**	
911	Deactivated	Deactivated	Deactivated	Deactivated	Secure mode	Fieldbus communication in normal operation.
912	_**	Deactivated	Deactivated	Deactivated	IloT-mode deactivated	
913	Deactivated	Deactivated	_**	_**	Web server and JSON disabled	
914	Activated	Activated	Activated	Activated	Activates all IloT protocols and the web server.	
915 - 978	_**				Reserved**	
979	Activated	Activated	Deactivated	Deactivated	Reset to default settings	Procedure only for this rotary switch position: <ol style="list-style-type: none"> 1. Disconnect the unit from the voltage supply. 2. Set switch position 979. 3. Connect the power supply. 4. Wait until reset is complete. <ul style="list-style-type: none"> • ST LED flashes green: Device is re-setting.

Position/ Range	Web server	JSON	OPC UA	MQTT	Description
					<ul style="list-style-type: none"> ST LED lights up green: Reset is complete. ST LED display, see 9.1.5 “LED Display Status” <ol style="list-style-type: none"> 1. Disconnect the power supply. 2. Switch position to 000 or another desired position. 3. Connect the power supply.
980-999	_**	_**	_**	_**	Reserved*



INFORMATION

* Note

Reserved switch positions have no fieldbus communication, see LED Display [► 71]



INFORMATION

** Note

The last protocol setting is retained.

Service Setting

The switch positions 911, 912 and 913 switch off the services of the device marked in the “Set Address” matrix. In these switch positions, the device starts normally with the previously set address configuration and has no function restrictions, except for the services deactivated by the switch position. The services deactivated as a result could not be activated again by other means, e.g. the configuration data of the control system.

Switch position 914 reactivates all services. Here too, the function of the device is not restricted.

1. Connect the power supply.
2. Disconnect the power supply.
3. Set original address.

Setting the Address



INFORMATION

Rotary switches are only re-adopted in the event of a power reset!

1. Disconnect the device power supply.
2. Remove the addressing cover.
3. Set a unique address.
4. Mount the addressing cover.
5. Connect the power supply.

The tightening torques can be found in section Addressing Cover [► 21]

6.1.2 Sensors and Actuators

Connect the M12 Socket

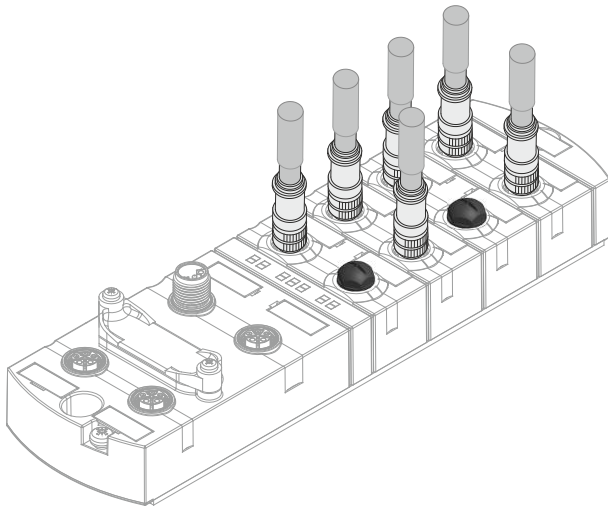
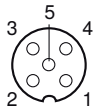

Example connection M12 inputs and outputs

Tightening torque 0.6 Nm

The pin assignment of the slots can be found in section “Pin Assignments [► 10]”



INFORMATION

Feeding in an external ground via the M12 sockets can lead to errors.

→ Do not feed any external ground into the device via the M12 sockets.



INFORMATION

The cable length of the sensor and actuator cables is limited to 30 m.

Sensor Power Supply

- Sensors can be supplied with power via **pin 1** (24 V) and **pin 3** (0 V) at the M12 sockets.
- The maximum permissible current for supplying the sensors is **2 A** per M12 socket.
- In the event of an overcurrent or short circuit, the connected wire or sensor must **be removed** from the M12 socket.

Status of IO-Link Communication

The device supports IO-Link communication at the following speeds:

- 4,800 baud (COM 1)
- 38,400 baud (COM 2)
- 230,400 baud (COM 3)



INFORMATION

The device automatically selects the correct transmission speed for the IO-Link device.



INFORMATION

The cable length for IO-Link connection is limited to max. 20 m.

6.1.3 Power Supply

Connect the M12 Plug POWER IN

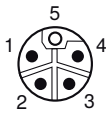

Connect M12 Socket POWER OUT

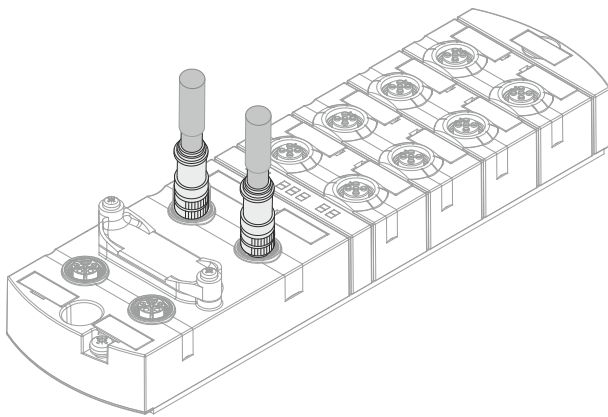
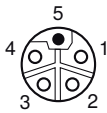

Example connection M12 POWER

Tightening torque 0.6 Nm

The pin assignment of the slots can be found in section “Pin Assignments [► 10]”

6.1.4 EtherCAT Communication

Connect the M12 Socket

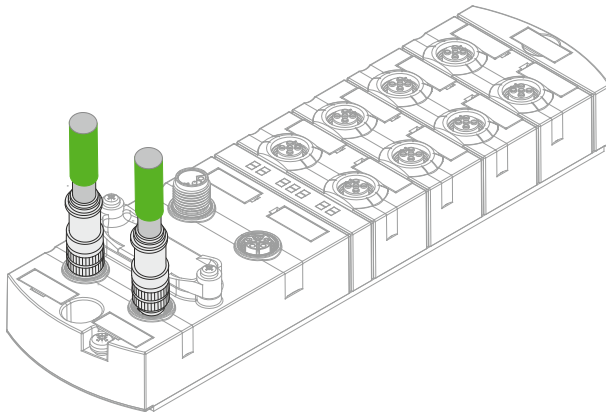
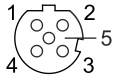

Example connection M12 BUS

Tightening torque 0.6 Nm

The pin assignment of the slots can be found in section “Pin Assignments [▶ 10]”

6.2 Ensure Tightness (IP67)



CAUTION

Leaky housing

Personal injury and material damage due to the ingress of conductive liquids in the event of device failure.

→ Seal unused plugs and sockets.

Connection Lines

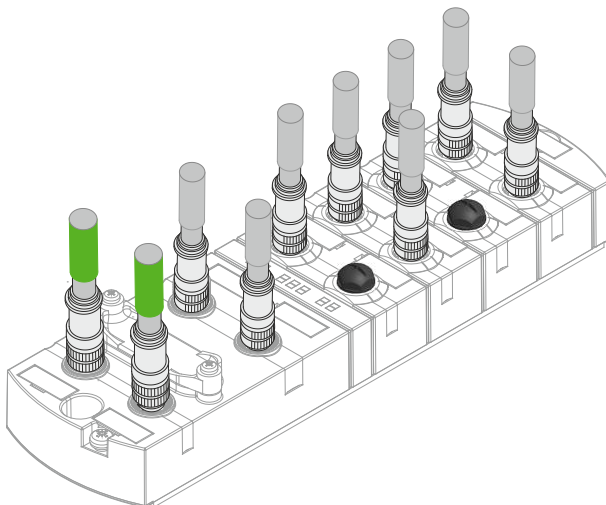

Connection lines

Tightening torque 0.6 Nm

7 Initial Start-Up



WARNING

Danger of burns!

It is forbidden to loosen or make electrical connections during operation. Failure to observe this rule results in a risk of arcing, which can cause burns.

→ Switch off the power supply to the unit



CAUTION

Uncontrolled processes

Property damage and personal injury due to incorrectly performed initial start-up phases (e.g. initial commissioning, re-commissioning and in the event of changes to the configuration).

→ Always perform initial start-up in this order:

1. Switch on the device.
2. Inspection and approval of the system by an expert.
3. Start up.



CAUTION

Malfunctions in the residential area

Equipment of EMC class A may cause interference in residential areas.

→ The operator must take appropriate measures

7.1 EtherCAT

Components

An EtherCAT network consists of at least the following components:

- 1 EtherCAT master
- 1 or more slave participants
- Ethernet lines and plugs for connecting the participants

7.1.1 Integrate Device into Beckhoff TwinCAT V3

The configuration and system integration are shown as an example for connecting the device to a Beckhoff TwinCAT controller with the “Twin-CAT® System Manager”. The exact procedure depends on the project planning software used.

If other controls and project management software are used, refer to the corresponding documentation.

Install ESI Files

Use the import function.

1. Download the ESI files from the website www.wenglor.com.
2. Copy the ESI file to the “TwinCAT” directory.

Default path: C:\TwinCAT\3.1\Config\Io\EtherCAT

The installed devices will be available the next time the TwinCAT System Manager is started.

7.1.2 Add a Device

The device can be added either by automatic scanning or manually.



INFORMATION

Before connecting devices to the EtherCAT network, the EtherCAT system must be in a safe, de-energized state.

Scan Device Automatically

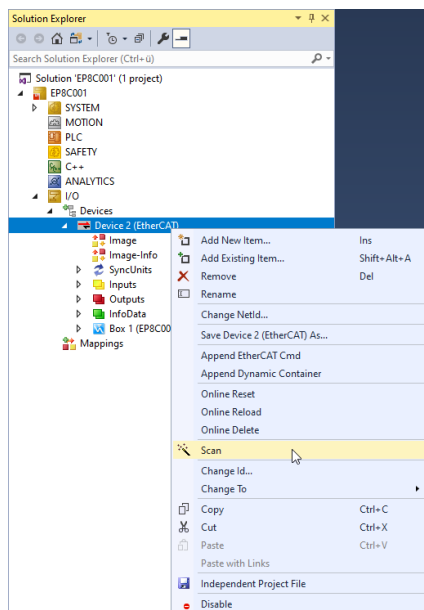

1. Switch on the operating voltage and start the TwinCAT System Manager in “Config mode”.
2. Switch on the supply voltage.
3. Scan the device.

Add Device Manually

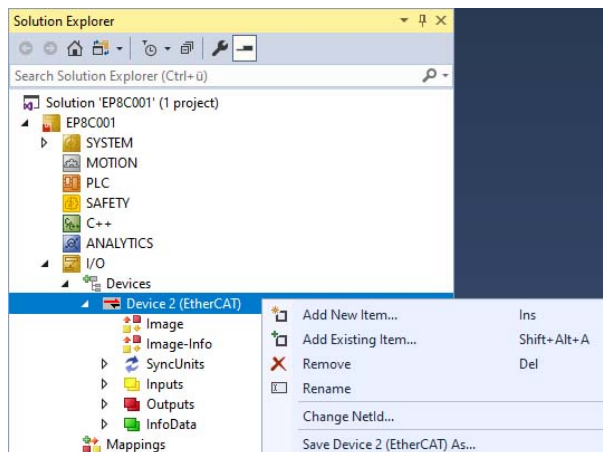

1. Switch on the operating voltage and start the TwinCAT System Manager in “Config mode”.
2. Switch on the supply voltage

Attach Device to Tree Structure

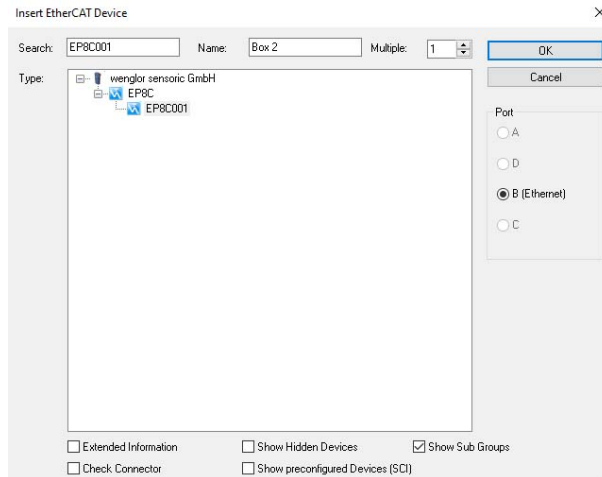

1. Select device.
2. Click OK

Necessary Adjustment on the Device

After automatic scanning or manual adding, the device appears in the TwinCAT tree structure

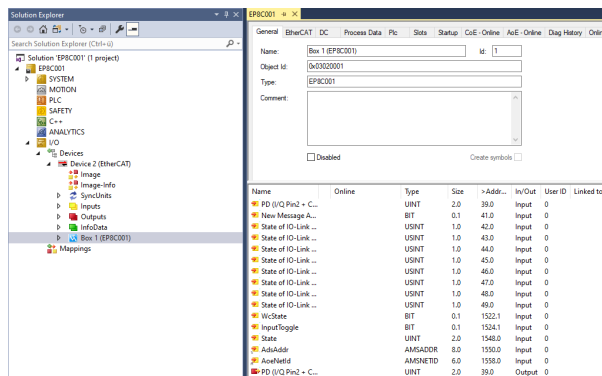

7.1.3 Explicit Device ID

Explicit Device ID is used for the EtherCAT function HotConnect. Device offers two ways to set the “identification value”:

1. via rotary switch
2. by writing the E²PROM

Set the Identification Value Using the Rotary Switch

Set the identification value on the EtherCAT tab.

This value is used for comparison with the value set with the rotary switches.

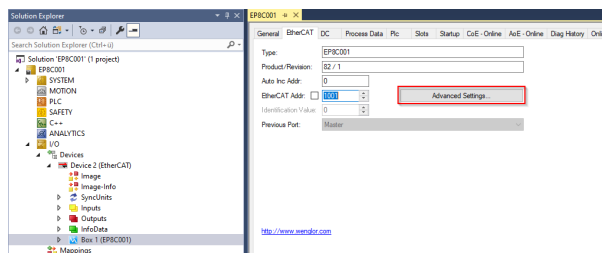

1. Select EtherCAT device EP8C001.
2. On the EtherCAT tab, select the “Advanced Settings” option.

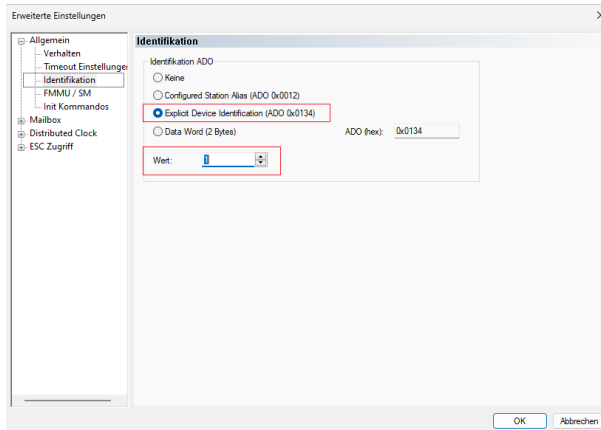

1. Under Identification, select > Explicit Device Identification.
2. Set the address under “Value”.

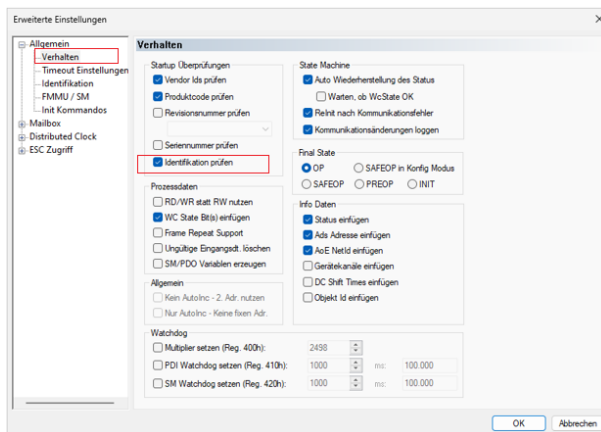

1. Under General > Behavior, check the “Check identification” checkbox.
2. Then click OK.
3. Switch off the device and set the same identification value with the rotary switches.
4. Switch the unit on again.
5. Compile project and download to PLC.

Set Identification via E² PROM

Set the identification value on the EtherCAT tab.

This value is used for comparison with the value set in the E²PROM.

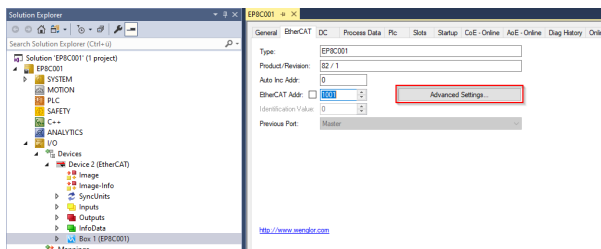

1. Select EtherCAT device EP8C001.
2. On the EtherCAT tab, select the “Advanced Settings” option.

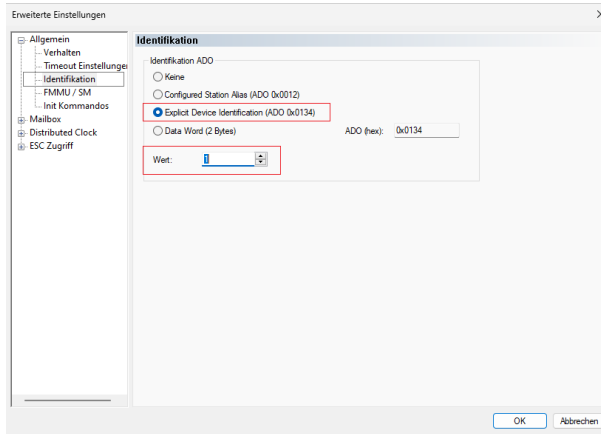

1. Under Identification, select > Explicit Device Identification.
2. Set the address under “Value”.

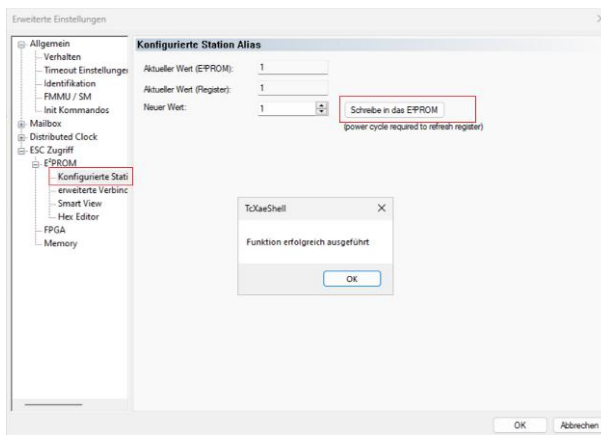

1. Select configured Station Alias.
2. Set the same identification value as previously set under New value.
3. Click Write to E²PROM.

The value address is saved in the E²PROM.

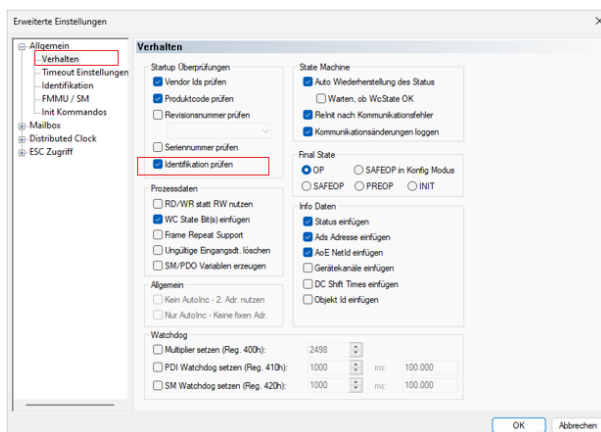

Under General > Behavior, check the “Check identification” checkbox.

Then click OK.

Switch the unit on again.

Compile project and download to PLC.

7.1.4 AoE

The master device supports reading and writing of IO-Link parameters via AoE (ADS over EtherCAT).

The acyclic communication to the IO-Link device is executed via an ADS command. The required ADS address consists of the NetID and the IO-Link master port number.

AoE NetID

The master device receives its own AoE NetID for communication with the IO-Link master part.

NetID is assigned by the configuration tool under:

- Box n 54632 or Box n 54612 > EtherCAT tab > Advanced Settings > Mailbox > AoE > Netid.

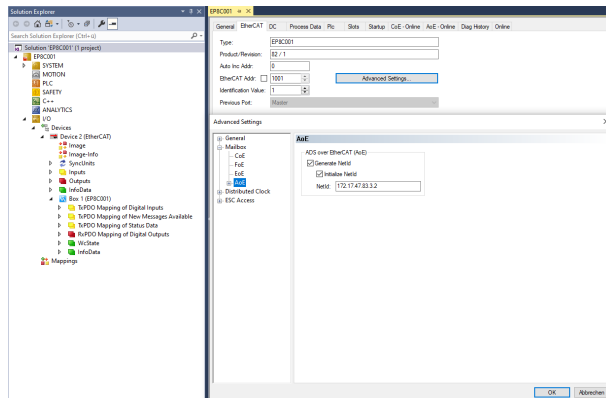

IO-Link Master Port Number

The individual IO-Link ports of the master device are assigned via the port number. The port numbers are assigned ascending from 0x1000 (4096dec).

The following applies to the IO-Link master:

Socket	Port number	Hex	Dec
X0	1	0x1000	4096
X1	2	0x1001	4097
X2	3	0x1002	4098
X3	4	0x1003	4099
X4	5	0x1004	5000
X5	6	0x1005	5001
X6	7	0x1006	5002
X7	8	0x1007	5003

ADS Index Group

In the IO-Link EtherCat integration xyz, the index group for the ADS command was set to **0xF302**, as with the CoE.

ADS Index Offset

The index and sub-index addressing of the IO-Link request is stored in the index offset. The index offset has a length of 4 bytes. The display is laid out as follows:

- 2 byte index
- 1 byte reserved
- 1 byte subindex

When reading out subindex 0x20 (32dec) of index 0x40 (64dec), index offset **0x00 40 00 20** is required:

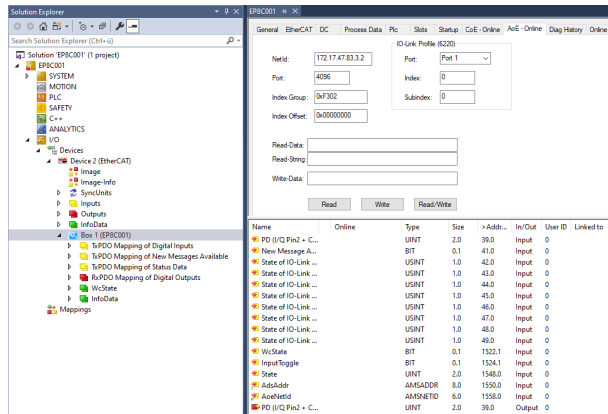

7.1.5 EoE

The device supports EoE (Ethernet over Ethercat).

To configure TwinCAT accordingly, select “Advanced Settings” in the EtherCAT tab.

- “EtherCAT®” tab > Advanced settings > Mailbox > EoE

A valid DNS name must be entered first and then a valid IP address.

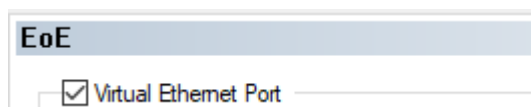
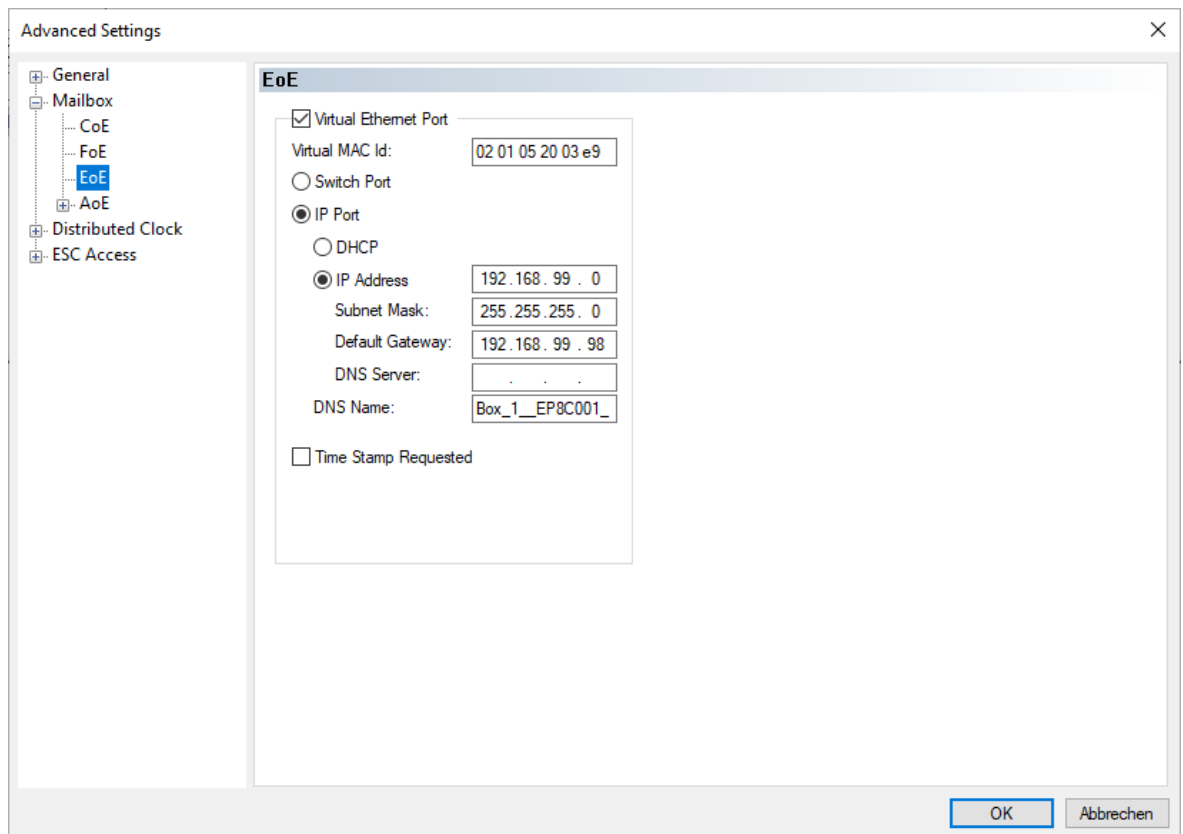



INFORMATION

The “FoE” function is activated at the factory. The function can be deactivated by selecting “Virtual Ethernet Port”.

7.1.6 Firmware Update via FoE

Prerequisites:

- TwinCAT V2 or V3
- Existing TwinCAT configuration including the EtherCAT slave to be updated.

Firmware Update (with TwinCAT V3)

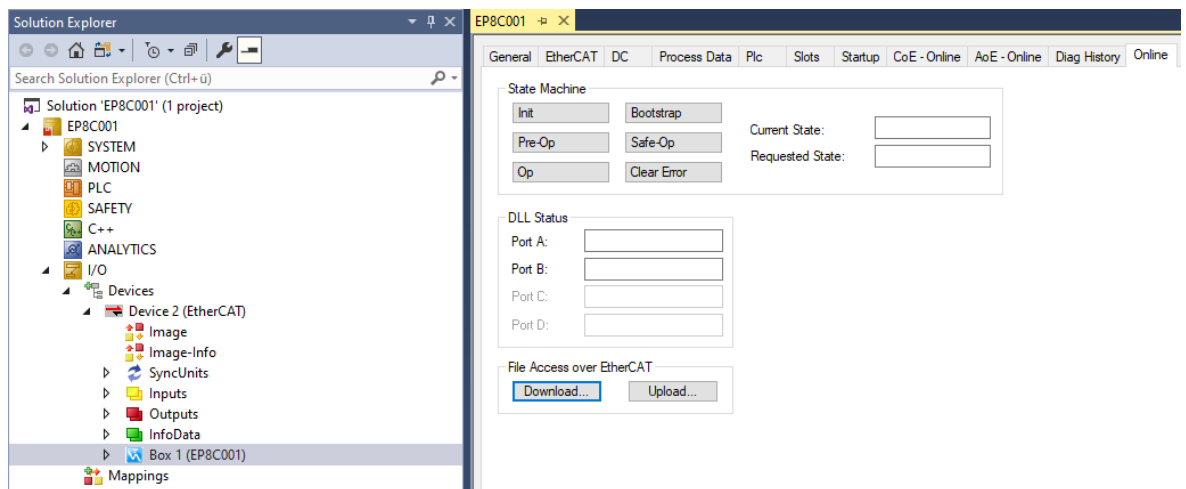

Download Firmware Update

1. Select file type All Files (*.*)
2. Download “fwupdate.zip” file
3. Click Open.

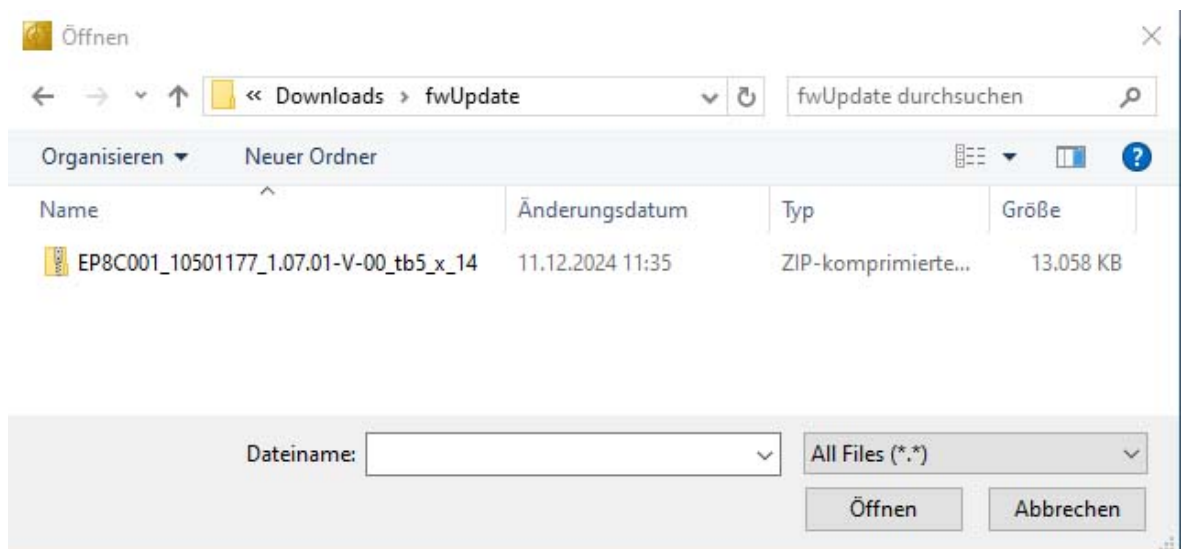

Enter FoE Name

1. Enter the FoE name “fwupdate.zip” in the String button.

2. Then click OK.

FoE Name Bearbeiten ✕

String:

Hex:

Länge:

Passwort (hex):



INFORMATION

Please wait until the download is complete (approx. 1 minute). TwinCAT does not update the screen while the download is active.

Open Firmware Update

1. Click on the CoE – Online tab.
2. Scroll down to the object “5FFE:0 Update Firmware” and open the sub-object “5FFE:01 Reset and Update FW immediately”.
3. Double-click on sub-object “5FFE:01 Reset and Update FW immediately”, reset and update firmware immediately.

54632 ✕

Allgemein **EtherCAT** DC Prozessdaten SPS Slots Startup **CoE - Online** AoE - Online Diag Historie Online

Auto Update Single Update Zeige Offline Daten

Modul OD (AoE Port):

Index	Name	Flags	Wert	Einheit
2270:0	IO-Link Port X7 Mailbox	RO	> 4 <	
3000:0	Digital Input and Status Data	RO	> 2 <	
3001:0	Digital Output and Status Data	RO	> 2 <	
5FFE:0	Update Firmware	WO	> 1 <	
5FFE:01	Reset and Update FW immed...	WO		
5FFF	Reset to Factory	WO		
6000:0	IO-Link In Port X0	RO	> 1 <	

Input Value

1. Enter any value from 1..255.
2. Then click OK.

Set Value Dialog ×

Dez:	<input type="text" value="1"/>	<input type="button" value="OK"/>
Hex:	<input type="text" value="0x01"/>	<input type="button" value="Abbruch"/>
Float:	<input type="text"/>	
Bool:	<input type="button" value="0"/> <input type="button" value="1"/>	<input type="button" value="Hex Edit..."/>
Binär:	<input type="text" value="01"/> <input type="button" value="1"/>	
Bitgröße	<input type="radio"/> 1 <input checked="" type="radio"/> 8 <input type="radio"/> 16 <input type="radio"/> 32 <input type="radio"/> 64 <input type="radio"/> ?	

Start Firmware Update

Device starts firmware update.

All status LEDs on the front are off.

After less than one minute, the device starts with the new firmware, see CoE object "100A Manufacturer's software version".

8 Configuration/Setting

8.1 Configure IO-Link Master

Structure of the IO-Link Master

The IO-Link master is a modular device with 8 slots.



INFORMATION

Each individual slot corresponds to an M12 socket pin 4.

A number of process data (buffer size) can be assigned to the slot. The connected device specifies the length of the process data at a port.

- Select the correct module depending on the connected device.

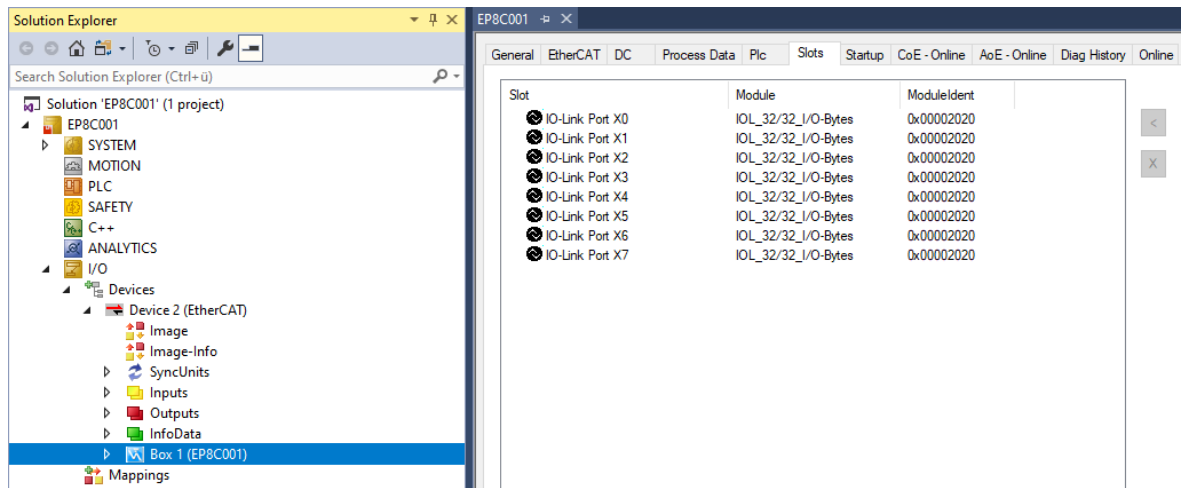

Slot Devices

Slot devices are structured according to the following scheme:

	Description
IOL_x/y_I/O-Bytes	Number of process data used for IO-Link device. The number should be equal to or greater than the process data length of the IO-Link device. <ul style="list-style-type: none"> • x: Input Data • y: Output data
Digital IN	Input pin 4
Digital OUT	Output pin 4
Slot deactivated	If pin 4 on slot is not used.

Module Overview

Slot empty
Digital_IN
Digital_OUT
IOL_1/0_I/O Byte
IOL_2/0_I/O Byte
IOL_4/0_I/O Byte

IOL_8/0_I/O Byte
IOL_16/0_I/O Byte
IOL_32/0_I/O Byte
IOL_0/1_I/O Byte
IOL_0/2_I/O Byte
IOL_0/4_I/O Byte
IOL_0/8_I/O Byte
IOL_0/16_I/O Byte
IOL_0/32_I/O Byte
IOL_1/1_I/O Byte
IOL_2/2_I/O Byte
IOL_4/4_I/O Byte
IOL_8/8_I/O Byte
IOL_16/16_I/OByte
IOL_32/32_I/OByte

8.2 Configure IO-Link Master Parameters

The “Startup” tab can be used to set the parameters of the module and the individual ports.

Transition	Protocol	Index	Data	Comment
<PS>	CoE	0x1A00 C 0	20 00 08 01 00 60 08 02 0...	download pdo 0x1A00 entr...
<PS>	CoE	0x1600 C 0	20 00 08 01 00 70 08 02 0...	download pdo 0x1600 entr...
<PS>	CoE	0x1A01 C 0	20 00 08 01 10 60 08 02 1...	download pdo 0x1A01 entr...
<PS>	CoE	0x1601 C 0	20 00 08 01 10 70 08 02 1...	download pdo 0x1601 entr...
<PS>	CoE	0x1A02 C 0	20 00 08 01 20 60 08 02 2...	download pdo 0x1A02 entr...
<PS>	CoE	0x1602 C 0	20 00 08 01 20 70 08 02 2...	download pdo 0x1602 entr...
<PS>	CoE	0x1A03 C 0	20 00 08 01 30 60 08 02 3...	download pdo 0x1A03 entr...
<PS>	CoE	0x1603 C 0	20 00 08 01 30 70 08 02 3...	download pdo 0x1603 entr...
<PS>	CoE	0x1A04 C 0	20 00 08 01 40 60 08 02 4...	download pdo 0x1A04 entr...
<PS>	CoE	0x1604 C 0	20 00 08 01 40 70 08 02 4...	download pdo 0x1604 entr...
<PS>	CoE	0x1A05 C 0	20 00 08 01 50 60 08 02 5...	download pdo 0x1A05 entr...
<PS>	CoE	0x1605 C 0	20 00 08 01 50 70 08 02 5...	download pdo 0x1605 entr...
<PS>	CoE	0x1A06 C 0	20 00 08 01 60 60 08 02 6...	download pdo 0x1A06 entr...
<PS>	CoE	0x1606 C 0	20 00 08 01 60 70 08 02 6...	download pdo 0x1606 entr...
<PS>	CoE	0x1A07 C 0	20 00 08 01 70 60 08 02 7...	download pdo 0x1A07 entr...
<PS>	CoE	0x1607 C 0	20 00 08 01 70 70 08 02 7...	download pdo 0x1607 entr...
<PS>	CoE	0x1C12 C 0	09 00 10 16 00 16 01 16 0...	download pdo 0x1C12 index
<PS>	CoE	0x1C13 C 0	08 00 10 1A 11 1A 80 1A ...	download pdo 0x1C13 index
<IP_PS>	AoE	1/3	AC.11.2F.53.03.02	AoE Init Cmd (download N...

Transition: I->P, P->S, S->P, S->O, O->S

Index (hex): 2140, Sub-Index (dez): 4

Daten (hexbin): [Hex Edit...]

Validate Mask: [Edit Entry...]

Comment: [Edit Entry...]

Set Value Dialog:

Dez: 4, Hex: 0x04, Enum: [Not supported, Digital Input NO normally open, Digital Input NC normally closed, Digital Output, Static On, Not supported], Bool: [Static On], Binär: [Not supported], Bitgröße: 1, 8, 16, 32, 64, ?

1. Select object.
 2. If ENUM is supported, the context menu can be called up and the values set.
- The settings are transferred when the configuration is uploaded.

Module Parameters

Pin/port-based IO layout defines the arrangement of the individual channels in the process data. This applies to both inputs and outputs.

Selection	Index	Subindex	Meaning
0*	0x2001	00	Port-based: The order is sorted in ascending order by port.
1			Pin-based: The arrangement is sorted in ascending order by pin.

* Bold entries are the default value of the specified parameter

DO Substitute Mode

If communication on the fieldbus is interrupted, the predefined state of the outputs occurs.

Selection	Index	Subindex	Meaning
0	0x2002	01	Off
1			On
2			Latest state

Port Parameter Pin4 (C/Q) SIO Mode and Pin2 (I/Q)

Parameterization of digital inputs and outputs for ports X0... X7:

Port X_ Pin4 (C/Q) SIO DI Invert:

Selection	Index	Subindex	Meaning
0*	0x2201	01	Port-based: The order is sorted in ascending order by port.
1			Pin-based: The arrangement is sorted in ascending order by pin.

Port X_ Pin4 (C/Q) SIO DI Filter Time:

Selection	Index	Subindex	Meaning
0	0x21n0	02	Without filter
10			1 ms
30			3 ms
50			5 ms
150			15 ms

Port X_ Pin2 (I/Q) Function:

Selection	Index	Subindex	Meaning
0	0x21n0	04	Digital input NO (normally open)
1			Digital input NC (normally closed)
2			digital output
3			Static digital output
4			Not supported

Port X_ Pin2 (I/Q) DI Filter Time:

Selection	Index	Subindex	Meaning
0	0x21n0	05	Without filter
10			1 ms
30			3 ms
50			5 ms
150			15 ms

IO-Link Master Parameters

Configuration Data Port X_:

Selection	Description
Device ID	Device ID of IO-Link device
Vendor ID	Manufacturer ID of the IO-Link device
IO-Link revision	Version of the implemented IO-Link specification (of the connected IO-Link device). 0: Plausibility check deactivated 11: Plausibility check activated
Cycle time	Cycle time that the master uses for the port. A value other than zero sets the IO-Link to manual mode: <ul style="list-style-type: none"> • 0: As fast as possible • 32: 3.2 ms • 40: 4.0 ms • 48: 4.8 ms • 68: 6.8 ms • 73: 10 ms • 88: 16 ms • 100: 20.8 ms • 128: 32 ms • 133: 40 ms • 148: 64 ms • 158: 80 ms • 183: 120 ms • 188: 128 ms
Process data IN length	Number and structure of input data
Process data OUT length	Number and structure of output data
Master control	IO-Link DataStorage functionality * <ul style="list-style-type: none"> • 0x003= No data memory • 0x023= Backup + restore • 0x043= Restore



INFORMATION

* When switching to the "Restore" state, any device configurations previously saved in the device are discarded, especially when switching from "Backup&Restore" to "Restore".

If a compatible device is connected for the first time in the "Restore" state:

- the master retrieves the data storage data (one-time backup) from the device once,
- saves them and
- sends this data consecutively to each newly connected compatible device with a different configuration (Restore).

8.3 General EtherCAT objects

Explanation of Elements

Access

Read and/or write access:

- RO: read-only
- RW: Read and write access

Default

Preset value

UINT

Unsigned INT data type

Device Type

Index	Name	Type	Access	Default value	Meaning
0x1000	Device Type	UINT32	RO	0x00000000	Device type of the EtherCAT slave: <ul style="list-style-type: none"> • The Lo-Word contains the CoE profile used (5001) • The Hi-Word contains the module profile according to the modular device profile.

Error Register

Index	Name	Type	Access	Default value	Meaning
0x1001	Error Register	UINT32	RO	0x00000000	Error Register Object Bit 0 = 1: Generic error Bit 1 = 1: Current error (SSC or ASC) Bit 2 = 1: Voltage error (LVS or LVA) Bit 3 ... 6: Reserved Bit 7 = 1: Internal device error (IME)

Manufacturer Device Name

Index	Name	Type	Access	Default value	Meaning
0x1008	Name	VISIBLE STRING	RO	EP8C001	Device name of the EtherCAT slave

Manufacturer Hardware Version

Index	Name	Type	Access	Default value	Meaning
0x1009	Hardware version	VISIBLE STRING	RO	Old hardware version	Hardware version of the EtherCAT slave

Manufacturer Software Version

Index	Name	Type	Access	Default value	Meaning
0x100A	Software version	VISIBLE STRING	RO	Actual firmware version	Firmware version of the EtherCAT slave

Identity Object

Index	Name	Type	Access	Default value	Meaning
0x1018:00	Identify object	UINT8	RO	0x04 (4dec)	Information of the slave
0x1018:01	Vendor ID	UINT32	RO	0x4F (79dec)	Vendor ID of EtherCAT slave device manufacturer
0x1018:02	Product code			0xDC70 (56432dec)	Product code of the EtherCAT slave
0x1018:03	Revision			0x00000000 (0dec)	Revision number of the EtherCAT slave; the Low Word (bit 0-15) indicates the special terminal number, the High Word (bit 16-31) refers to the device description
0x1018:04	Serial number			0x00000000 (0dec)	Serial number of EtherCAT slave <ul style="list-style-type: none"> the high word (bits 31-16) contains a consecutive number the upper byte of the low word (bits 15-8) contains the manufacturing week the lower byte of the low word (bits 7-0) contains the manufacturing year

Timestamp Object

Index	Name	Type	Access	Default value	Meaning
0x1018:F8	Timestamp Object	UINT64	RO	-	Local timestamp of the device in ns

Diagnostics History

Index	Name	Type	Access	Default value	Meaning
0x10F3	Diagnostics History	RECORD			
0x10F3:0	Diagnostics History	UINT8	RO	255	Highest supported subindex
0x10F3:1	Maximum Messages	UINT8	RO	0xFA (250dec)	Number of diagnostics messages which can be stored in the diagnostics history (subindex 6 onwards)
0x10F3:2	Newest Message	UINT8	RO	0	Subindex of the newest diagnostics message (6-255)
0x10F3:3	Newest Acknowledged Message	UINT8	RW	0	<p>Overwrite Mode (SI5, bit 4 = 0):</p> <p>Read = 0: When the message queue will be overwritten, the slave sets SI3 to 0.</p> <p>Writing = 0: The slave clears all messages, i.e. resets SI2, SI3, SI4 and SI5 bit 5*</p> <p>Writing = 1...5: The slave returns SDO abort with code 0x06090030 (Value range of parameter exceeded)</p> <p>Writing = 6..255: SI3 = written value (without checking)**</p> <p>Acknowledge Mode (SI5, bit 4 = 1):</p> <p>Read = 0:</p>

Index	Name	Type	Access	Default value	Meaning
					<p>No messages have been acknowledged so far</p> <p>Read != 0:</p> <p>Subindex of latest acknowledged diagnostics message (6-69)</p> <p>Writing = 0:</p> <p>All acknowledged messages will be deleted</p> <p>Writing = 1...5:</p> <p>The slave returns SDO abort with code 0x06090032 (value of parameter written too low)</p> <p>Writing = 6...255:</p> <p>Messages are acknowledged***</p>
0x10F3:4	New Messages Available	BIOOL	RO	0	<p>Overwrite Mode:</p> <ul style="list-style-type: none"> 0: newest message was read 1: newest message was not read <p>Acknowledge mode:</p> <ul style="list-style-type: none"> 0: no unacknowledged message 1: diagnostics messages are available which can be acknowledged (SI2 !=SI3)
0x10F3:5	Flags	UINT2	RW	0x0000 (0dec)	<p>Flags to control sending and storing of diagnostics messages</p> <p>Bit 0: Enable Emergency sending</p> <p>0: default if device does not support emergency sending</p> <p>1: new diagnostics messages shall be sent as emergency message</p> <p>Bit 1: Disable info messages</p> <p>0: Info messages are stored in the diagnostics message queue (default)</p> <p>1: Info messages will not be stored in the diagnostics message queue</p> <p>Bit 2: Disable warning messages</p> <p>0 : Warning messages are stored in the diagnostics message queue (default)</p> <p>1: Warning messages will not be stored in the diagnostics message queue</p> <p>Bit 3: Disable error messages</p> <p>0: Error messages are stored in the diagnostics message queue (default)</p> <p>1: Error messages will not be stored in the diagnostics message queue</p> <p>Bit 4: Mode selection for diagnostics history handling</p> <p>0: Overwrite Mode: old messages are overwritten by new ones when buffer is full</p> <p>1: Acknowledge mode: New messages do only overwrite messages which were acknowledged before</p> <p>Bit 5: Overwrite/Discard Information (read only)</p> <p>In Overwrite mode:</p>

Index	Name	Type	Access	Default value	Meaning
					0: unacknowledged messages have been overwritten (= buffer overrun) (SI3 is set to 0, too) In Acknowledge mode: 1: message buffer is full with acknowledged messages and a new message is discarded Bit 6.-15: reserved
0x10F3:6-255	Diagnostics Message	OCTET – STRING	RO		Diagnostics message buffer. Depending on SI1 the EtherCAT slave can store up to 250 messages; the first message is stored in subindex 6, the second in subindex 7 and so on. When the queue is full, the EtherCAT slave shall overwrite subindex 6 and so on, that always the latest maximum messages (SI1) shall be accessible by the EtherCAT master.

*) Messages are deleted even if they were not acknowledged or read before.

***) All messages up to the age of the message which is in the written subindex are acknowledged. The slave does not check if those messages have been read before. The slave returns SDO abort with code 0x06090030 (value range of parameter exceeded) in the following case: If SI3 is written with a value of a Subindex which does not hold a message.

****) All messages up to the age of the message which is in the written subindex are acknowledged. The slave does not check if those messages have been read before. The slave returns SDO abort with code 0x06090030 (value range of parameter exceeded) in the following case: If SI3 is written with a value of a Subindex which does not hold a message.

Subindex 0: Highest Supported Subindex

The diagnostic history can contain a maximum of as many diagnostic messages as in subindex 1: Maximum Messages is specified. These can be called up starting with subindex 6. Subindex 0 indicates the highest subindex under which a diagnostic message is stored.

Subindex 1: Maximum Messages

The diagnostic history can contain as many diagnostic messages as specified here. This value is maximum 250.

Subindex 2: Newest Message

You can use subindex 2 to query under which subindex the latest diagnostic message is currently stored in the diagnostic history. The value should be between 6 and 255. If no diagnostic messages are currently stored, the value 0 is returned.

Subindex 3: Newest Acknowledged Message

This sub-index contains the sub-index of the latest confirmed diagnostics message. It can be both read and written. In both cases, the meaning of the values depends on the current mode.

The following applies:

- Overwrite mode (subindex 5, bit 4 = 0) and
- Acknowledge mode (Subindex 5, bit 4 = 1).

Overwrite mode:

Read = 0:

When the queue for diagnostic messages is overwritten, the EtherCAT slave subindex 3 sets to 0.

Writing = 0:

If the value 0 is written to subindex 3, the EtherCAT slave deletes or sets subindex 2, subindex 3, subindex 4 and subindex 5 bit 5.



INFORMATION

Diagnostic messages are deleted even if they have not been confirmed or read beforehand.

Writing = 1...5:

The slave returns SDO abort with error code 0x06090032 (written parameter value too low).

Writing = 6...255:

Subindex 3 = value is overwritten (without check).

Acknowledge Mode

Read = 0:

No diagnostics messages have been acknowledged so far (Acknowledge).

Read != 0:

Subindex of the last confirmed diagnostic message (6-255)

Writing = 0:

All confirmed diagnostic messages are deleted.

Writing = 1...5:

The slave returns SDO abort with error code 0x06090032 (written parameter value too low).

Writing = 6...255:

The diagnostic messages are acknowledged (Acknowledge).



INFORMATION

All diagnostic messages up to the age of the message that is in the subindex currently being written are acknowledged (Acknowledge). The EtherCAT slave does not check whether these diagnostic messages have been read beforehand.

If subindex 3 is described with the number of a subindex that does not contain a diagnostics message. The slave returns SDO abort with error code 0x06090030 (exceeding the value range of the parameter).

Subindex 4: New Messages Available

Overwrite mode:

0: The latest diagnostic message was read.

1: The latest diagnostic message was not read.

Acknowledge mode

0: No unacknowledged diagnostic message present.

1: There are diagnostic messages that can be confirmed.

Subindex 5: Flags

Bit 0: Enable emergency messages

0	Default if the device cannot send emergency messages.
1	New diagnostic messages are sent as emergency messages.

Bit 1: Disable info messages

0	Info messages are stored in the queue for diagnostic messages.
1	Info messages are not stored in the queue for diagnostic messages.

Bit 2: Disable warning messages

0	Warning messages are stored in the queue for diagnostic messages.
1	Warning messages are not stored in the queue for diagnostic messages.

Bit 3: Disable error messages

0	Error messages are stored in the queue for diagnostic messages.
1	Error messages are not stored in the queue for diagnostic messages.

Bit 4: Mode selection for response to diagnostic history buffer overflow

0	Overwrite mode: when the buffer is full, old diagnostic messages are overwritten by new ones.
1	Acknowledge mode New diagnostic messages only overwrite older messages if they have been confirmed beforehand.

Bit 5: Overwrite and discard information (read only)

In overwrite mode:

1	Unconfirmed diagnostic messages were overwritten (= buffer overflow). Subindex 3 was also set to 0.
---	---

In confirmation mode:

1	The diagnostic message buffer is full of confirmed messages and a new diagnostic message is discarded.
---	--

Bit 6-15: Reserved

--	--

Subindex 6-255: Diagnostics Message

Subindex 6-255: Diagnostics message buffer

Depending on subindex 1, the EtherCAT slave can store up to 250 diagnostic messages. The first message is stored in subindex 6, the second in subindex 7, etc. When the buffer is full, the EtherCAT slave overwrites subindex 6 etc. so that the last diagnostic messages are accessible for the EtherCAT master. Their exact number is specified by subindex 1.

8.4 Bitmapping and Process Data of the Device

When used in an EtherCAT master system, these objects are assigned by the wenglor EtherCAT IO-Link master in the address range of the EtherCAT master. The process data is structured as follows:

TxPDO/RxPDOAssignment IO-Link Slots

Process data assignment for digital channels or IO-Link device to pin 4.

- When a slot is set to Digital IN or Digital OUT, a byte of process data is always assigned to that slot. The status channel of the respective slot itself is available in the entire process data, i.e. in "TxPDO Mapping of digital Inputs" or "RxPDO Mapping of digital Outputs".
- If the slot is set to **IOL_x/y_I/O byte**, a certain number of bytes are always assigned as process data that correspond to the type (input/output) and size (x/y).

Input/output area							
Byte 0	Byte 1	Byte 2					Byte 31
Process data	Process data	Process data					Process data
Byte 0	Byte 1	Byte 2					Byte 31

TxPDO Assignment of Digital Inputs

Process data assignment for digital inputs on pin 4 and pin 2

Pin4 (C/Q) + Pin2 (I/Q) - Port-based data layout

Input byte n							
Bit 0	Bit 1	Bit 2	Bit 3	Bit 4	Bit 5	Bit 6	Bit 7
Port X0	Port X0	Port X1	Port X2	Port X2	Port X2	Port X3	Port X3
Pin 4	Pin 2	Pin 4	Pin 2	Pin 4	Pin 2	Pin 4	Pin 2
Input byte n+1							
Bit 0	Bit 1	Bit 2	Bit 3	Bit 4	Bit 5	Bit 6	Bit 7
Port X4	Port X4	Port X5	Port X5	Port X6	Port X6	Port X7	Port X7
Pin 4	Pin 2	Pin 4	Pin 2	Pin 4	Pin 2	Pin 4	Pin 2

Pin4 (C/Q) + Pin2 (I/Q) - Pin-based data layout

Input byte n							
Bit 0	Bit 1	Bit 2	Bit 3	Bit 4	Bit 5	Bit 6	Bit 7
Port X0	Port X1	Port X2	Port X3	Port X4	Port X5	Port X6	Port X7
Pin 4	Pin 4	Pin 4	Pin 4	Pin 4	Pin 4	Pin 4	Pin 4
Input byte n+1							
Bit 0	Bit 1	Bit 2	Bit 3	Bit 4	Bit 5	Bit 6	Bit 7
Port X0	Port X1	Port X2	Port X3	Port X4	Port X5	Port X6	Port X7
Pin 2	Pin 2	Pin 2	Pin 2	Pin 2	Pin 2	Pin 2	Pin 2

TxPDO Assignment of Digital Outputs

Process data assignment for digital outputs on pin 4 and pin 2.

Input byte n							
Bit 0	Bit 1	Bit 2	Bit 3	Bit 4	Bit 5	Bit 6	Bit 7
Port X0	Port X0	Port X1	Port X2	Port X2	Port X2	Port X3	Port X3
Pin 4	Pin 2	Pin 4	Pin 2	Pin 4	Pin 2	Pin 4	Pin 2
Input byte n+1							
Bit 0	Bit 1	Bit 2	Bit 3	Bit 4	Bit 5	Bit 6	Bit 7
Port X4	Port X4	Port X5	Port X5	Port X6	Port X6	Port X7	Port X7
Pin 4	Pin 2	Pin 4	Pin 2	Pin 4	Pin 2	Pin 4	Pin 2

Input byte n							
Bit 0	Bit 1	Bit 2	Bit 3	Bit 4	Bit 5	Bit 6	Bit 7
Port X0	Port X1	Port X2	Port X3	Port X4	Port X5	Port X6	Port X7
Pin 4	Pin 4	Pin 4	Pin 4	Pin 4	Pin 4	Pin 4	Pin 4
Input byte n+1							
Bit 0	Bit 1	Bit 2	Bit 3	Bit 4	Bit 5	Bit 6	Bit 7
Port X0	Port X1	Port X2	Port X3	Port X4	Port X5	Port X6	Port X7
Pin 2	Pin 2	Pin 2	Pin 2	Pin 2	Pin 2	Pin 2	Pin 2

Pin4 (C/Q) + Pin2 (I/Q) - Pin-based data layout

TxPDO Assignment of New Available Messages

Overwrite Mode	0: newest message was read
----------------	----------------------------

	1: newest message was not read
Acknowledge Mode	0: no unacknowledged message
	1: diagnostics messages are available which can be acknowledged

TxPDO Assignment of Status Data

A status byte is available for each port.

State of IO-Link port X_

Input byte n	0: Port not enabled
	1: SIO mode digital input
	2: SIO mode digital output
	3: IO-Link communication enabled
	4: IO-Link communication deactivated

State of IO-Link Port n_(n represents the Subindex/Module position)

Bit 0...3 IO-Link State	0x00 (0dec)	Port Inactive
	0x01 (1dec)	Siomode Digital In
	0x02 (2dec)	Siomode Digital Out
	0x03 (3dec)	Communication OP
	0x04 (4dec)	Communication STOP
Bit 4...7 ErrorCode	0x00 (0dec)	No error
	0x10 (16dec)	Watchdog Error
	0x20 (32dec)	Buffer Overflow
	0x30 (48dec)	Invalid Device ID
	0x40 (64dec)	Invalid Vendor ID
	0x50 (80dec)	Invalid IO-Link Revision
	0x60 (96dec)	Invalid Frame Capability
	0x70 (112dec)	Invalid Cycle Time
	0x80 (128dec)	Invalid Length processdata
	0x90 (144dec)	Invalid Length processdata
	0xA0 (160dec)	No Device detected
	0xB0 (172dec)	Error PreOP

8.5 Distributed Clocks (DC)

The device supports the forwarding of DC messages and can itself serve as a reference clock. The internal timestamps are limited to 32 bits.

Erweiterte Einstellungen X

- Allgemein
- Mailbox
- Distributed Clock
- Assign to local
- Latch
- ESC Zugriff

Distributed Clock

Zyklischer Modus

Betriebsart: Free Run

Aktivieren Sync Unit Zyklus (µs) 4000

SYNC 0

Zykluszeit (µs):

Sync Unit Zyklus x 1 4000

Anwenderdefiniert

Shift Zeit (µs):

User Defined 0

+ SYNC0 Cycle x 0 0

Basierend auf Eingangs Referenz

+

= 0

SYNC 0 aktivieren

SYNC 1

Sync Unit Zyklus Zykluszeit (µs): 4000

SYNC 0 Zyklus x 1 Shift Zeit (µs): 0

SYNC 1 aktivieren

Use as potential Reference Clock

OK
Abbrechen



INFORMATION

Synchronization of the device's local ports with the DC is not planned.

8.6 Industrial Internet of Things (IIoT)

8.6.1 JSON

General JSON Settings

No.	REST API URL	Description	Sup-ports
1	GET /iolink/v1/gateway/identification	Identification of the gateway	OK
2	GET /iolink/v1/gateway/capabilities	Capabilities of the gateway	OK
3	GET /iolink/v1/gateway/configuration	Read network configuration of the gateway	OK
4	POST /iolink/v1/gateway/configuration	Write network configuration of the gateway	OK
5	POST /iolink/v1/gateway/reset	Reset the gateway including all masters	-
6	POST /iolink/v1/gateway/reboot	Reboot the gateway including all masters	-
7	GET /iolink/v1/gateway/events	Event log containing all events from gateway, masters, ports and devices	OK
8	GET /iolink/v1/masters	Get all available master number keys and identification information	OK

No.	REST API URL	Description	Sup-ports
9	GET /iolink/v1/masters/\$MASTER_NUMBER/capabilities	Capabilities of the master	OK
10	GET /iolink/v1/masters/\$MASTER_NUMBER/identification	Read identification of the master	OK
11	POST /iolink/v1/masters/\$MASTER_NUMBER/identification	Write identification of the master	OK
12	GET /iolink/v1/masters/\$MASTER_NUMBER/ports	Get all available port number keys	OK
13	GET /iolink/v1/masters/\$MASTER_NUMBER/ports/\$PORT_NUMBER/capabilities	Read capability information of the specified port	OK
14	GET /iolink/v1/masters/\$MASTER_NUMBER/ports/\$PORT_NUMBER/status	Read status of the master	OK
15	GET /iolink/v1/masters/\$MASTER_NUMBER/ports/\$PORT_NUMBER/configuration	Read configuration of the specified port	OK
16	POST /iolink/v1/masters/\$MASTER_NUMBER/ports/\$PORT_NUMBER/configuration	Write configuration of the specified port	OK
17	GET /iolink/v1/masters/\$MASTER_NUMBER/ports/\$PORT_NUMBER/datastorage	Read data storage content of the specified port	OK
18	POST /iolink/v1/masters/\$MASTER_NUMBER/ports/\$PORT_NUMBER/datastorage	Write data storage content of the specified port	OK
19	GET /iolink/v1/devices	Address all devices of all masters	OK
20	GET /iolink/v1/devices/{deviceAlias}/capabilities	Read capability information of the specified device	OK
21	GET /iolink/v1/devices/{deviceAlias}/identification	Read identification information of the specified device	OK
22	POST /iolink/v1/devices/{deviceAlias}/identification	Write identification information of the specified device	-
23	GET /iolink/v1/devices/{deviceAlias}/processdata/value?format=byteArray	Read process data value from the specified device	OK
24	GET /iolink/v1/devices/{deviceAlias}/processdata/getdata/value?format=byteArray	Read process data input value from the specified device	OK
25	GET /iolink/v1/devices/{deviceAlias}/processdata/setdata/value?format=byteArray	Read process data output value from the specified device	OK
26	POST /iolink/v1/devices/{deviceAlias}/processdata/value	Write the process data output value to the specified device	OK
27	GET /iolink/v1/devices/{deviceAlias}/parameters/{index}/value/?format=byteArray	Read a specific parameter value and its sub-parameter values (if the parameter has complex type) with the given index of the device	OK
28	GET /iolink/v1/devices/{deviceAlias}/parameters/{index}/subindices/{subindex}/value/?format=byteArray	Read the value of a specific sub-parameter with the given index and subindex	OK
29	GET /iolink/v1/devices/{deviceAlias}/parameters/{parameterName}/value/?format=byteArray	Read a specific parameter value with the given name	-
30	POST /iolink/v1/devices/{deviceAlias}/parameters/{index}/value	Write the parameter with the given index to the device	OK
31	POST /iolink/v1/devices/{deviceAlias}/parameters/{parameterName}/value	Write the parameter with the given name to the device	-

No.	REST API URL	Description	Supports
32	POST /iolink/v1/devices/{deviceAlias}/parameters/{index}/subindices/{subindex}/value	Write the sub-parameter with the given index and subindex to the device	OK
33	POST /iolink/v1/devices/{deviceAlias}/parameters/{parameterName}/subindices/{subParameterName}/value	Write the sub-parameter with the given parameter name and sub-parameter name to the device	OK
34	POST /iolink/v1/devices/{deviceAlias}/blockparametrization/?format=byteArray	Read or write one or more parameters as a block	OK
35	GET /iolink/v1/devices/{deviceAlias}/events	Read event log from the specified device	OK
36	GET /iolink/v1/mqtt/configuration	Read configuration of MQTT clients	OK
37	POST /iolink/v1/mqtt/configuration	Write configuration of MQTT clients	-
38	GET /iolink/v1/mqtt/topics	Read list of MQTT topics	-
39	POST /iolink/v1/mqtt/topics	Write list of MQTT topics	-
40	DELETE /iolink/v1/mqtt/topics/{topicID}	Delete a specific MQTT topic	-
41	GET /iolink/v1/mqtt/topics/{topicID}	Read a specific MQTT topic	-
42	GET /iolink/v1/mqtt/connectionstatus	Read connection status	OK

Vendor-Specific JSON Settings

No.	REST API URL	Description	Supports
43	GET /iolink/v1/vendor/masters/\$MASTER_NUMBER/diagnostics/configuration	Diagnostic configuration of the master	OK
44	GET /iolink/v1/vendor/masters/\$MASTER_NUMBER/diagnostics/value	Diagnostic values of the master	OK
45	GET /iolink/v1/vendor/masters/\$MASTER_NUMBER/ports/\$PORT_NUMBER/statistics/current	Current statistic values of the specified port of the master	OK
46	GET /iolink/v1/vendor/masters/\$MASTER_NUMBER/ports/\$PORT_NUMBER/statistics/voltage	Voltage statistic values of the specified port of the master	OK
47	GET /iolink/v1/vendor/masters/\$MASTER_NUMBER/ports/\$PORT_NUMBER/statistics/temperature	Temperature statistic values of the specified port of the master	OK
48	GET /iolink/v1/vendor/masters/1/ports/1/statistics/stack	IO-Link stack statistic values of the specified port of the master	-
49	GET /iolink/v1/vendor/masters/\$MASTER_NUMBER/ports/\$PORT_NUMBER/diagnostics/configuration	Diagnostic configuration of the specified port of the master	OK
50	GET /iolink/v1/vendor/masters/\$MASTER_NUMBER/ports/\$PORT_NUMBER/diagnostics/current	Diagnostic current value of the specified port of the master	OK
51	GET /iolink/v1/vendor/masters/\$MASTER_NUMBER/ports/\$PORT_NUMBER/diagnostics/voltage	Diagnostic voltage value of the specified port of the master	OK
52	GET /iolink/v1/vendor/masters/\$MASTER_NUMBER/ports/\$PORT_NUMBER/diagnostics/temperature	Diagnostic temperature value of the specified port of the master	OK

No.	REST API URL	Description	Sup-ports
	\$MASTER_NUMBER/ports/ \$PORT_NUMBER/diagnostics/tempera- ture		

8.6.2 MQTT



INFORMATION

When activating MQTT, JSON must be activated.

MQTT Settings

No.	REST API URL	Description
1	\$MQTT_CLIENT_HEAD_TOPIC/iolink/v1/gateway/identifi- cation	Identification of the gateway
2	\$MQTT_CLIENT_HEAD_TOPIC/iolink/v1/gateway/capa- bilities	Capabilities of the gateway
3	\$MQTT_CLIENT_HEAD_TOPIC/iolink/v1/gateway/con- figuration	Network configuration of the gateway
4	\$MQTT_CLIENT_HEAD_TOPIC/iolink/v1/masters	Get all available master number keys and identification information
5	\$MQTT_CLIENT_HEAD_TOPIC/iolink/v1/vendor/mas- ters/ \$MASTER_NUMBER/diagnostics/value	Diagnostic values of the master
6	\$MQTT_CLIENT_HEAD_TOPIC/iolink/v1/vendor/mas- ters/ \$MASTER_NUMBER/diagnostics/configuration	Diagnostic configuration of the master
7	\$MQTT_CLIENT_HEAD_TOPIC/iolink/v1/masters/ \$MASTER_NUMBER/capabilities	Capabilities of the master
8	\$MQTT_CLIENT_HEAD_TOPIC/iolink/v1/masters/ \$MASTER_NUMBER/identification	Identification of the master
9	\$MQTT_CLIENT_HEAD_TOPIC/iolink/v1/masters/ \$MASTER_NUMBER/ports	Get all available port number keys
10	\$MQTT_CLIENT_HEAD_TOPIC/iolink/v1/masters/ \$MASTER_NUMBER/ports/\$PORT_NUMBER/capabili- ties	Read capability information of the specified port
11	\$MQTT_CLIENT_HEAD_TOPIC/iolink/v1/masters/ \$MASTER_NUMBER/ports/\$PORT_NUMBER/status	Read actual status of the specified port
12	\$MQTT_CLIENT_HEAD_TOPIC/iolink/v1/masters/ \$MASTER_NUMBER/ports/\$PORT_NUMBER/configura- tion	Read/Write configuration of the speci- fied port
13	\$MQTT_CLIENT_HEAD_TOPIC/iolink/v1/vendor/mas- ters/ \$MASTER_NUMBER/ports/\$PORT_NUMBER/diagnos- tics/Configuration	Diagnostic configuration of the speci- fied port of the master
14	\$MQTT_CLIENT_HEAD_TOPIC/iolink/v1/vendor/mas- ters/ \$MASTER_NUMBER/ports/\$PORT_NUMBER/diagnos- tics/current	Diagnostic current value of the speci- fied port of the master
15	\$MQTT_CLIENT_HEAD_TOPIC/iolink/v1/vendor/mas- ters/	Diagnostic voltage value of the speci- fied port of the master

No.	REST API URL	Description
	\$MASTER_NUMBER/ports/\$PORT_NUMBER/diagnostics/voltage	
16	\$MQTT_CLIENT_HEAD_TOPIC/iolink/v1/vendor/masters/ \$MASTER_NUMBER/ports/\$PORT_NUMBER/diagnostics/temperature	Diagnostic temperature value of the specified port of the master
17	\$MQTT_CLIENT_HEAD_TOPIC/iolink/v1/vendor/masters/ \$MASTER_NUMBER/ports/\$PORT_NUMBER/statistics/current	Current statistic values of the specified port of the master
18	\$MQTT_CLIENT_HEAD_TOPIC/iolink/v1/vendor/masters/ \$MASTER_NUMBER/ports/\$PORT_NUMBER/statistics/voltage	Voltage statistic values of the specified port of the master
19	\$MQTT_CLIENT_HEAD_TOPIC/iolink/v1/vendor/masters/ \$MASTER_NUMBER/ports/\$PORT_NUMBER/statistics/temperature	Temperature statistic values of the specified port of the master
20	\$MQTT_CLIENT_HEAD_TOPIC/iolink/v1/devices/ \$DEVICE_ALIAS/processdata/value	Read/Write process data value from/to the specified device
21	\$MQTT_CLIENT_HEAD_TOPIC/iolink/v1/devices/ \$DEVICE_ALIAS/processdata/getdata/value	Read process data input value from the specified device
22	\$MQTT_CLIENT_HEAD_TOPIC/iolink/v1/devices/ \$DEVICE_ALIAS/processdata/setdata/value	Temperature statistic values of the specified port of the master
23	\$MQTT_CLIENT_HEAD_TOPIC/iolink/v1/devices/ \$DEVICE_ALIAS/events	Read/Write process data value from/to the specified device
24	\$MQTT_CLIENT_HEAD_TOPIC/Asset	Read process data output value from the specified device
25	\$MQTT_CLIENT_HEAD_TOPIC/iolink/v1/devices/ \$DEVICE_ALIAS/events	Read event log from the specified device

8.6.3 OPC UA

The devices mentioned in the screenshots serve as examples.

The device has an OPC-UA server. An OPC UA client can connect to the device and access the following parameters:

- Device identification,
- Configuration parameters,
- Process data,
- Measured values,
- Diagnostics Information,
- Statistical information, etc.

The OPC UA client connects using the following URL:

opc.tcp://IP address:4840



INFORMATION

For **IP address**, the IP address of the device is used.

The client can access device parameters anonymously (read only) or with username/password (read and write). The user name and password are set with the web server.

The following figure shows a section of the device's information model.

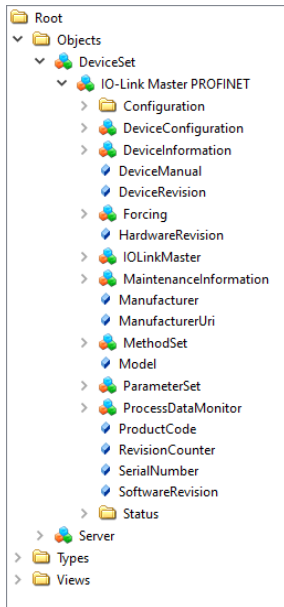

The following figure shows a section of the information model of an IO-Link port.

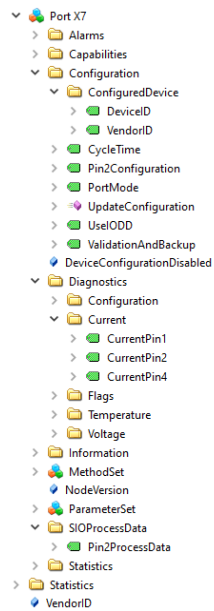

8.6.3.1 Authenticate

User Login

For OPC UA, the same users and passwords apply as documented in the web server description 10 “Web server”

A connection to the OPC UA server is started with the user “guest”, with which read access to the OPC UA objects is possible.

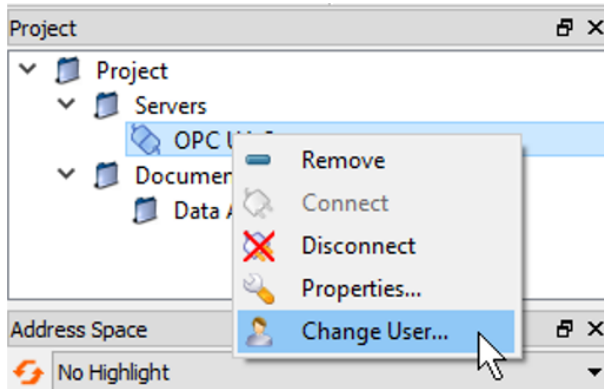

The user must be switched over for further actions.

- Username <admin>
- Password <private>

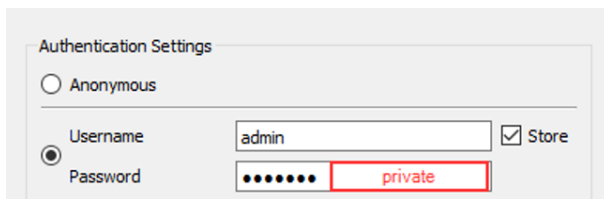

Forcing

Digital outputs can be switched manually (forcing) via OPC UA.

Step 1

Use the GetForcingID method to generate an ID from the device.

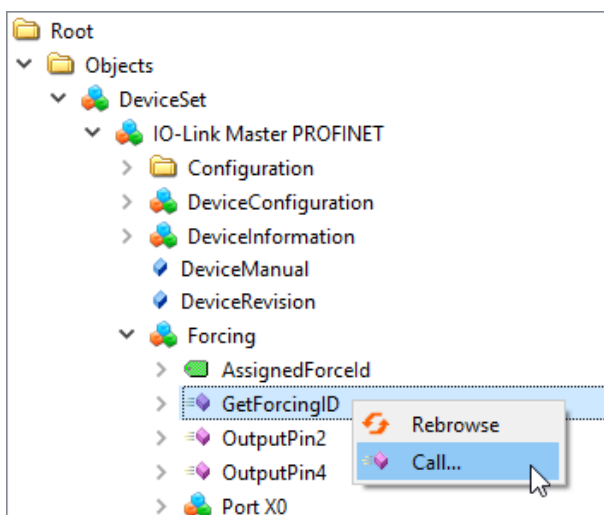

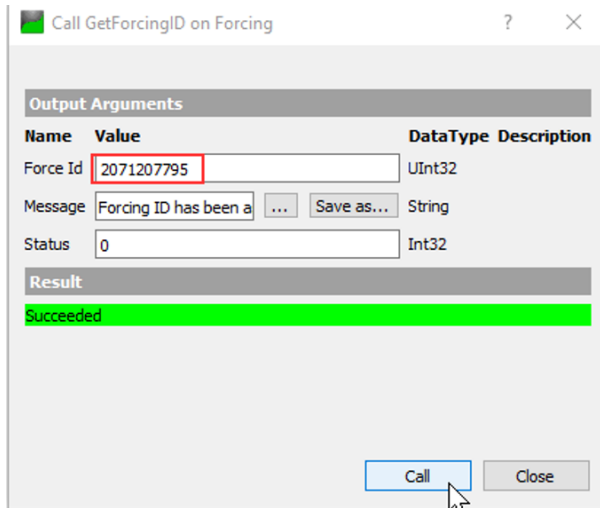

INFORMATION

The ForcingID is only valid for 10 seconds. The validity is extended to 10 seconds each time a forcing function is called up.

Step 2

Set digital outputs using the OutputPin2 or OutputPin4 methods.

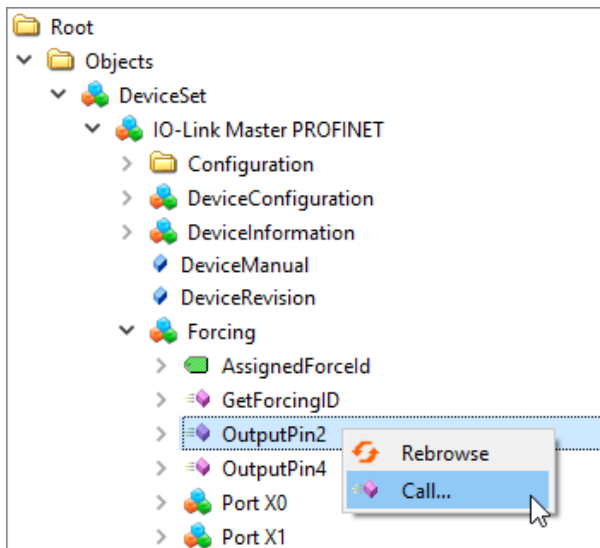

The method expects the received forcing ID, a bit mask and data to be written to be entered as parameters.

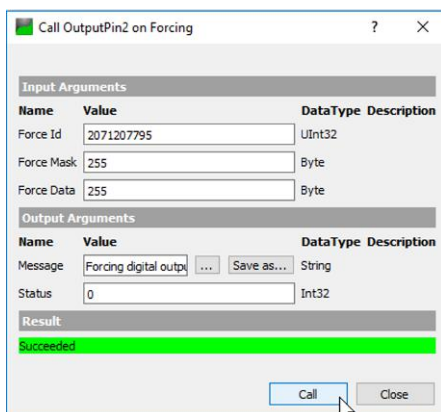

8.6.3.2 Device Identification

The device provides nodes for device identification. For example, the OPC UA client can read the version of the device firmware used in the **SoftwareRevision** node.

Node name	Node class	Access	Description
Manufacturer	Variable	Read	Device manufacturer
ManufacturerUri	Variable	Read	Device manufacturer URL
Model	Variable	Read	Model designation of the device
ProductCode	Variable	Read	Product code of the device
RevisionCounter	Variable	Read	Device hardware revision
SerialNumber	Variable	Read	Serial number of device
SoftwareRevision	Variable	Read	Device firmware revision/version

#	Server	Node Id	Display Name	Value	Datatype	Source Timestamp	Server Timestamp	Statuscode
1	OPC UA ...	NS6 Numeric 161	Manufacturer	"en", "wenglor ...	LocalizedText	06:27:09.000	06:27:09.000	Good
2	OPC UA ...	NS6 Numeric 166	ManufacturerUri	www.wenglor.c...	String	06:27:16.000	06:27:16.000	Good
3	OPC UA ...	NS6 Numeric 162	Model	"en", "IO-Link ...	LocalizedText	06:27:38.000	06:27:38.000	Good
4	OPC UA ...	NS6 Numeric 167	ProductCode	EP8P001	String	06:27:49.000	06:27:49.000	Good
5	OPC UA ...	NS6 Numeric 163	RevisionCounter	1	Int32	06:27:51.000	06:27:51.000	Good

8.6.3.3 Configuration Parameters

The OPC UA server provides nodes with configuration parameters of the device. For example, the OPC UA client can read the upper limit for the temperature in the **OverTemperature** node.

Device-Related Configuration Parameters

Node name	Node class	Access	Default	Description
CurrentHysteresis	Variable	Read	10 mA	Current hysteresis, unit: mA If the current exceeds the limit value, the current must first fall below the limit value again by the hysteresis value in order to cancel the diagnostics.
OverTemperature	Variable	Read	70 °C	Upper limit for the temperature of a port, unit: 0.1 °C
OverVoltageL	Variable	Read	30 V	Upper limit value for the voltage in supply line 1, pins can be monitored with the function L+, DI, DO, DIO, IO-Link, unit: mV
OverVoltageL2	Variable	Read	30 V	Upper limit for the voltage in supply line 2, unit: mV
TemperatureHysteresis	Variable	Read	2 °C	Temperature hysteresis, unit: 0.1 °C If the temperature exceeds the limit value, the temperature must first fall below the limit value by the hysteresis value in order to cancel the diagnostics.
UnderTemperature	Variable	Read	-25 °C	Lower limit for the temperature of a port, unit: 0.1 °C
UnderVoltage L	Variable	Read	18 V	Lower limit value for the voltage in supply line 1, pins can be monitored with the function L+, DI, DO, DIO, IO-Link, unit: mV
UnderVoltage L2	Variable	Read	18 V	Lower limit for the voltage in supply line 2, unit: mV
Voltage Hysteresis	Variable	Read	300 mV	Voltage hysteresis, unit: mV

Node name	Node class	Access	Default	Description
				If the voltage exceeds the limit value, the voltage must first drop back below the limit value by the hysteresis value in order to cancel the diagnostics.

#	Server	Node Id	Display Name	Value	Datatype	Source Timestamp	Server Timestamp	Statuscode
1	OPC UA ...	NS6(Numeric...	CurrentHysteresis	10	UInt16	06:29:43.000	06:29:43.000	Good
2	OPC UA ...	NS6(Numeric...	OverTemperature	70	Float	06:29:48.000	06:29:48.000	Good
3	OPC UA ...	NS6(Numeric...	OverVoltageL	30000	Int32	06:29:51.000	06:29:51.000	Good
4	OPC UA ...	NS6(Numeric...	OverVoltageL2	30000	Int32	06:29:54.000	06:29:54.000	Good
5	OPC UA ...	NS6(Numeric...	TemperatureHy...	2	Float	06:29:56.000	06:29:56.000	Good
6	OPC UA ...	NS6(Numeric...	UnderTemperat...	-40	Float	06:29:57.000	06:29:57.000	Good
7	OPC UA ...	NS6(Numeric...	UnderVoltageL	17000	Int32	06:29:59.000	06:29:59.000	Good
8	OPC UA ...	NS6(Numeric...	UnderVoltageL2	17000	Int32	06:30:00.000	06:30:00.000	Good
9	OPC UA ...	NS6(Numeric...	VoltageHysteresis	300	UInt16	06:30:01.000	06:30:01.000	Good

Port-Related Configuration Parameters

Node name	Node class	Access	Default	Description
OverCurrentPin1, OverCurrentPin2, OverCurrentPin4	Variable	Read	0	Warning level for upper current limit at pin 1, pin 2 or pin 4, unit: 1 mA 0: Monitoring not activated
UnderCurrentPin1, UnderCurrentPin2, UnderCurrentPin4	Variable	Read	0	Warning level for lower current limit at pin 1, pin 2 or pin 4, unit: 1 mA 0: Monitoring not activated

The screenshot shows the 'Address Space' tree on the left and the 'Data Access View' table on the right. The tree is expanded to 'IO-Link Master > Diagnostics > Configuration > UnderCurrentPin4'. The table lists 6 rows of data for various current pins.

#	Server	Node Id	Display Name	Value	Datatype	Source Timestamp	Server Timestamp	Statuscode
1	OPC UA ...	NS6[Numeric...	OverCurrentPin1	0	Int32	06:31:26.000	06:31:26.000	Good
2	OPC UA ...	NS6[Numeric...	OverCurrentPin2	0	Int32	06:31:26.000	06:31:26.000	Good
3	OPC UA ...	NS6[Numeric...	OverCurrentPin4	0	Int32	06:31:27.000	06:31:27.000	Good
4	OPC UA ...	NS6[Numeric...	UnderCurrentPi...	0	Int32	06:31:28.000	06:31:28.000	Good
5	OPC UA ...	NS6[Numeric...	UnderCurrentPi...	0	Int32	06:31:28.000	06:31:28.000	Good
6	OPC UA ...	NS6[Numeric...	UnderCurrentPi...	0	Int32	06:31:29.000	06:31:29.000	Good

8.6.3.4 Process Data

The OPC UA server provides nodes with process data. For example, the OPC UA client can read the value at pin 2 of a port in the node **Pin2ProcessData**.

Node name	Node class	Access	Description
Pin2ProcessData	Variable	Read	Process data to pin 2
Pin4ProcessData	Variable	Read	Process data to pin 4

The screenshot shows the 'Address Space' tree on the left and the 'Data Access View' table on the right. The tree is expanded to 'IO-Link Master > Diagnostics > SIOProcessData > Pin2ProcessData'. The table lists 2 rows of data for process data nodes.

#	Server	Node Id	Display Name	Value	Datatype	Server Timestamp	Source Timestamp	Statuscode
1	OPC UA ...	NS6[Numeric...	Pin2ProcessData	false	Boolean	06:32:34.000	06:32:34.000	Good
2	OPC UA ...	NS6[Numeric...	Pin4ProcessData	false	Boolean	06:32:35.000	06:32:35.000	Good

8.6.3.5 Measured Values

The OPC UA server provides nodes with calculated measured values. For example, the OPC UA client can read the calculated sum current of supply line 1 in node **SumCurrentL**.

Device-Related Measured Values

Node name	Node class	Access	Description
SumCurrentL	Variable	Read	Total current calculated from individual measurements in supply line 1, unit: mA
SumCurrentL2	Variable	Read	Total current calculated from individual measurements in supply line 2, unit: mA
MeanTemperature	Variable	Read	Mean value for the temperature of the assembly, calculated from the temperature values measured individually at the three chips, unit: °C
MeanVoltageL	Variable	Read	Mean voltage in supply line 1, unit: mV
MeanVoltageL2	Variable	Read	Mean voltage in supply line 2, unit: mV

#	Server	Node Id	Display Name	Value	Datatype	Server Timestamp	Source Timestamp	Statuscode
1	OPC UA ...	NS6(Numeric...	SumCurrentL	89	Int32	06:34:44.000	06:34:44.000	Good
2	OPC UA ...	NS6(Numeric...	SumCurrentL2	0	Int32	06:34:25.000	06:34:25.000	Good
3	OPC UA ...	NS6(Numeric...	MeanTemperat...	34.5	Float	06:34:29.000	06:34:29.000	Good
4	OPC UA ...	NS6(Numeric...	MeanVoltageL	23837	Int32	06:34:44.000	06:34:44.000	Good
5	OPC UA ...	NS6(Numeric...	MeanVoltageL2	24245	Int32	06:34:44.000	06:34:44.000	Good

Port-Related Measured Values

Node name	Node class	Access	Description
CurrentPin1, CurrentPin2, CurrentPin4	Variable	Read	Current measured at pin 1, pin 2 or pin 4, unit: mA
TemperaturePin1, TemperaturePin2, TemperaturePin4	Variable	Read	Temperature measured at pin 1, pin 2 or pin 4, unit: °C
VoltagePin1, VoltagePin2, VoltagePin4	Variable	Read	Voltage measured at pin 1, pin 2 or pin 4, unit: mA

#	Server	Node Id	Display Name	Value	Datatype	Server Timestamp	Source Timestamp	StatusCode
1	OPC UA ...	NS0(Numeric...	CurrentPin1	12	Int32	06:35:57.000	06:35:57.000	Good
2	OPC UA ...	NS0(Numeric...	CurrentPin2	0	Int32	06:35:40.000	06:35:40.000	Good
3	OPC UA ...	NS0(Numeric...	CurrentPin4	0	Int32	06:35:41.000	06:35:41.000	Good
4	OPC UA ...	NS0(Numeric...	MaxTemperatur...	35,7	Float	06:35:45.000	05:54:48.000	Good
5	OPC UA ...	NS0(Numeric...	MaxTemperatur...	35,7	Float	06:35:45.000	03:17:01.000	Good
6	OPC UA ...	NS0(Numeric...	MaxTemperatur...	35,7	Float	06:35:46.000	03:17:17.000	Good
7	OPC UA ...	NS0(Numeric...	VoltagePin1	23890	Int32	06:35:57.000	06:35:57.000	Good
8	OPC UA ...	NS0(Numeric...	VoltagePin2	-113	Int32	06:35:57.000	06:35:57.000	Good
9	OPC UA ...	NS0(Numeric...	VoltagePin4	-102	Int32	06:35:57.000	06:35:57.000	Good

8.6.3.6 Diagnostics

The OPC UA server provides nodes with diagnostic information. For example, the OPC UA client can read in the DiagnosticsPin1 node whether the device has detected an overcurrent on pin 1 of a port.

Node name	Node class	Access	Description
DiagnosticsPin1, DiagnosticsPin2, DiagnosticsPin4	Variable	Read	<p>Diagnostics at pin 1, pin 2 or pin 4. The numeric value contains bit-coded information:</p> <ul style="list-style-type: none"> • Bit 0: Short circuit, • Bit 1: Overload protection, • Bit 2: Over-temperature protection, • Bit 3: Overvoltage protection, • Bit 4: Overcurrent, • Bit 5: Undercurrent <p>Bit 0: Over-temperature Bit 1: Under-temperature Bit 2: Overvoltage Bit 3: Undervoltage Bit 4: Watchdog</p> <p>0: Diagnostics not active 1: Diagnostics active</p>

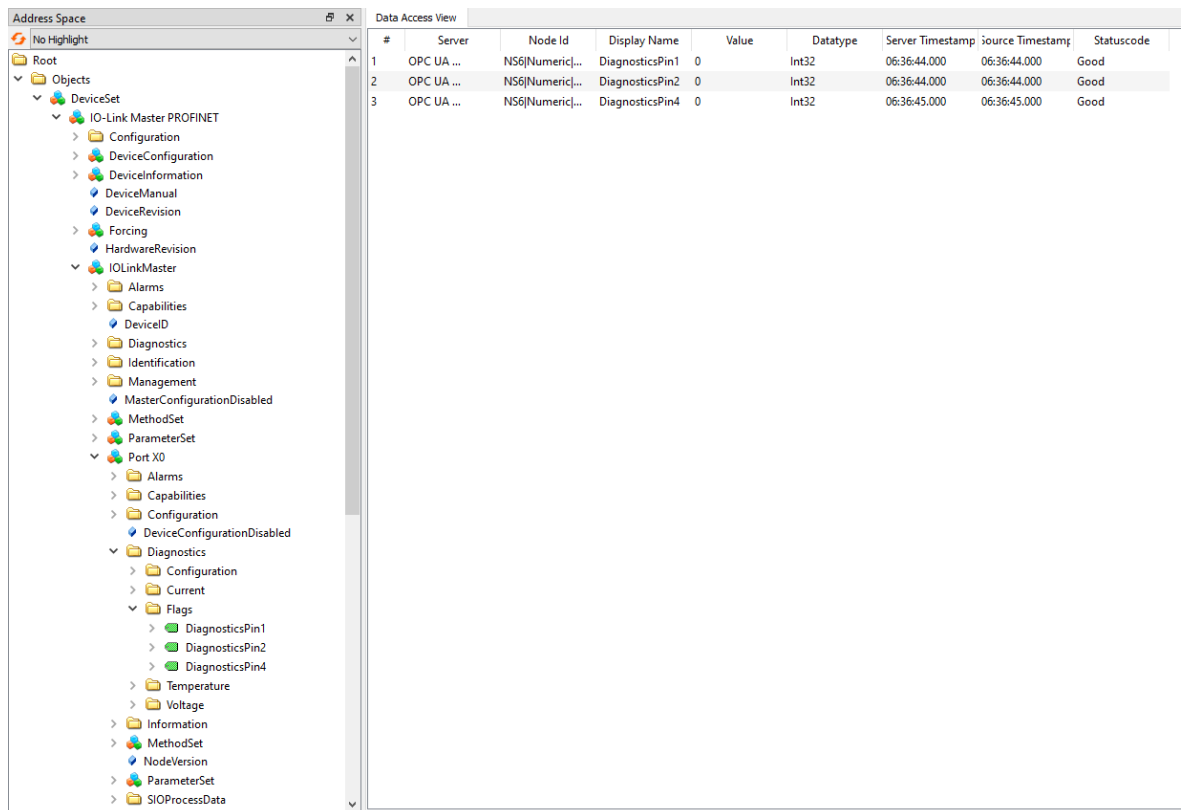

8.6.3.7 Statistics

The OPC UA server provides nodes with statistical information. For example, the OPC UA client can read the maximum measured current at pin 1 of a port in node **MaxCurrentPin1**.

Node name	Node class	Access	Description
Current			
MaxCurrentPin1, MaxCurrentPin2, MaxCurrentPin4	Variable	Read	Maximum current at pin 1, pin 2 or pin 4 since reset of value, unit: mA
MinCurrentPin1, MinCurrentPin2, MinCurrentPin4	Variable	Read	Minimum current at pin 1, pin 2 or pin 4 since reset of value, unit: mA
Temperature			
MaxTemperaturePin1, MaxTemperaturePin2, MaxTemperaturePin4	Variable	Read	Maximum temperature at pin 1, pin 2 or pin 4 since reset of value, unit: °C
MinTemperaturePin1, MinTemperaturePin2, MinTemperaturePin4	Variable	Read	Minimum temperature at pin 1, pin 2 or pin 4 since reset of value, unit: °C
Template			
MaxVoltagePin1, MaxVoltagePin2, MaxVoltagePin4	Variable	Read	Maximum voltage at pin 1, pin 2 or pin 4 since resetting the value, unit: mV
MinVoltagePin1, MinVoltagePin2, MinVoltagePin4	Variable	Read	Minimum voltage at pin 1, pin 2 or pin 4 since reset of value, unit: mV

#	Server	Node Id	Display Name	Value	Datatype
1	OPC UA Server	NS6 Numeric 34...	MaxCurrentPin1	109	Int32
2	OPC UA Server	NS6 Numeric 34...	MaxCurrentPin2	0	Int32
3	OPC UA Server	NS6 Numeric 34...	MaxCurrentPin4	0	Int32
4	OPC UA Server	NS6 Numeric 34...	MinCurrentPin1	104	Int32
5	OPC UA Server	NS6 Numeric 34...	MinCurrentPin2	0	Int32
6	OPC UA Server	NS6 Numeric 34...	MinCurrentPin4	0	Int32
7	OPC UA Server	NS6 Numeric 34...	MaxTemperaturePin1	43.7	Float
8	OPC UA Server	NS6 Numeric 34...	MaxTemperaturePin2	43.7	Float
9	OPC UA Server	NS6 Numeric 34...	MaxTemperaturePin4	43.7	Float
10	OPC UA Server	NS6 Numeric 34...	MinTemperaturePin1	42.2	Float
11	OPC UA Server	NS6 Numeric 34...	MinTemperaturePin2	42.2	Float
12	OPC UA Server	NS6 Numeric 34...	MinTemperaturePin4	42.2	Float
13	OPC UA Server	NS6 Numeric 34...	MaxVoltagePin1	23550	Int32
14	OPC UA Server	NS6 Numeric 34...	MaxVoltagePin2	-220	Int32
15	OPC UA Server	NS6 Numeric 34...	MaxVoltagePin4	-213	Int32
16	OPC UA Server	NS6 Numeric 34...	MinVoltagePin1	23525	Int32
17	OPC UA Server	NS6 Numeric 34...	MinVoltagePin2	-244	Int32
18	OPC UA Server	NS6 Numeric 34...	MinVoltagePin4	-233	Int32

8.6.3.8 NTP Client Configuration

The OPC UA server provides nodes for configuring the NTP client.

Node name	Node class	Access	Description
NtpClientServerIpAddress	Variable	Read/ write	<ul style="list-style-type: none"> IP address of the NTP server The NTP client uses the set IP address to get the time from an NTP server. The IP address must be converted to a decimal number. The calculation is described according to the table. The value 0 disables the function.
NtpClientServerIpAddressFallback	Variable	Read/ write	<ul style="list-style-type: none"> IP address of the NTP server (fallback) The optional additional IP address if the NTP server cannot be reached via the IP address in node NtpClientServerIpAddress. The IP address must be converted to a decimal number. The calculation is described according to the table. The value 0 disables the function.
NtpClientUpdateConfiguration	Variable	Write	Method for writing the nodes NtpClientServerIpAddress and NtpClientServerIpAddressFallback.

The following formula is used to convert the IP address to a decimal number. Starting from an IP address in A.B.C.D format:

$$((A * 256 + B) * 256 + C) * 256 + D = \text{IP address as a decimal number}$$

Example for IP address 192.53.103.108

8.6.3.9 OPC UA PC Client

The IO-Link master is equipped with an integrated web server. With an OPC UA client, you can communicate with the IO-Link master.

For test purposes, the UaExpert from Unified Automation GmbH can be used, for example: www.unifiedautomation.com

An OPC UA client can access the IO-Link master in read mode with “anonymous” authentication.

An OPC UA client can access the IO-Link master in read and write mode with the authentication “User name and password” if the user used has write permissions.

Connect to IO-Link Master

Prerequisites

- You have an OPC UA client.
- If you want to write to the IO-Link master: You know the username and password and have write access.
- You know the IP address of the IO-Link master.

Without a user name and password, you can access the IO-Link Master “anonymously” and read data.

Step-by-Step Instructions

Establish a connection to the IO-Link master:

- Start UaExpert
- Use File > New to create a new project.
- Use Server > Add to add a new server.

The Add Server dialog appears with the Discovery tab.

Discovery tab (default)

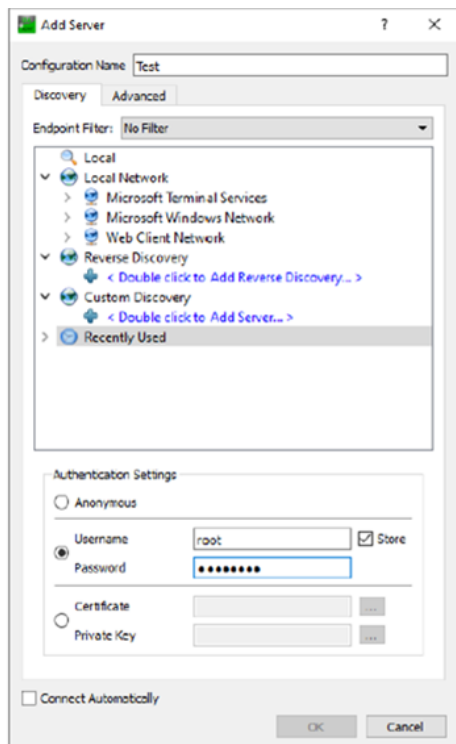

Advanced tab

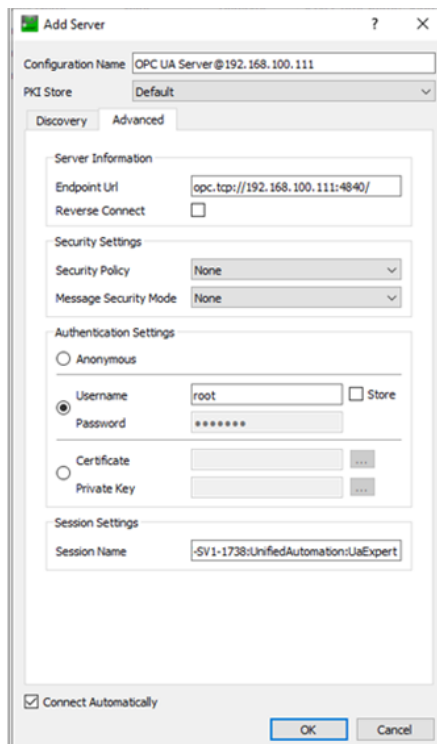

- In the Configuration name field, enter a name for your configuration, e.g. Test.
- Select the Advanced tab.
- In the Server Information section of the Advanced tab, enter the following in the Endpoint Url data field: `opc.tcp://<IP Address>;4840` For `<IP Address>`, enter the device's IP address.
- In the Authentication Settings area, select Username/Password if you want write access to the device or Anonymous if read access is sufficient.
- If you have selected the Username/Password option, enter your username and, if applicable, your password there.
- Then click OK.

In the project window, the UaExpert enters the server under Project >Servers, e.g. Test.

- Open the context menu of the server (Test) and select Connect.

The connection is established.

Prerequisites

- You have an OPC UA client.
- You know the username and password and have write access.
- You know the IP address of an NTP server.
- You have converted the IP address of this NTP server to a decimal number as described below.
- You have already established a connection to the MVK device.

Example of an NTP Server

NTP server `ptbtime1.ptb.de` of the Physikalisch-Technische Bundesanstalt in Braunschweig with the IP address `192.53.103.108`

Replacement NTP server (optional) of the NTP server `ptbtime2.ptb.de` of the Physikalisch-Technische Bundesanstalt in Braunschweig with the IP address `192.53.103.104`

Converting an IP address to a decimal number

The following formula is used to convert the IP address to a decimal number. Starting from an IP address in A.B.C.D format:

$$((A * 256 + B) * 256 + C) * 256 + D = \text{IP address as a decimal number}$$

Example for IP address `192.53.103.108`

$$((192 * 256 + 53) * 256 + 103) * 256 + 108 = 3224725356$$

Step-by-Step Instructions

- In the Address Space window, open the context menu:

Root> Objects> DeviceSet> [Device name] > Configuration> NtpClient>NtpClientUpdateConfiguration.

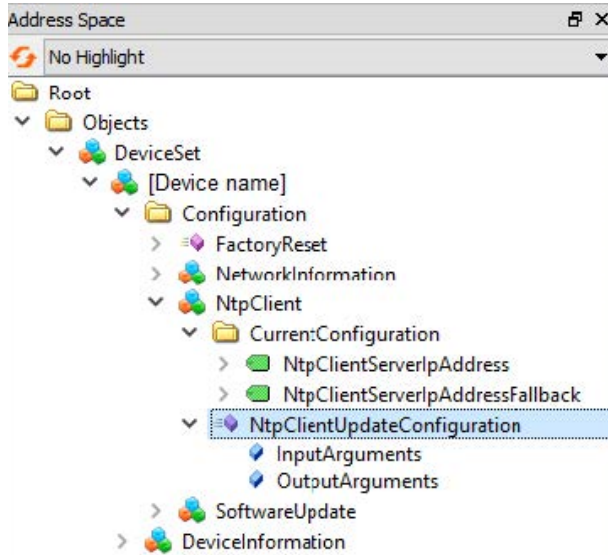

- Select Call from the context menu.

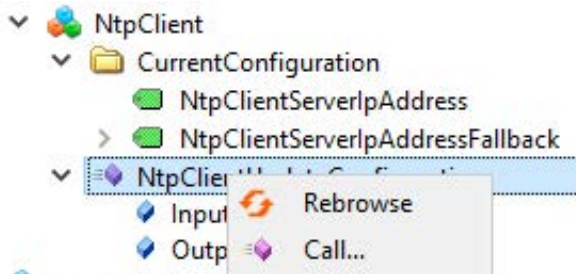

The Call **NtpClientUpdateConfiguration on NtpClient** dialog box is displayed:

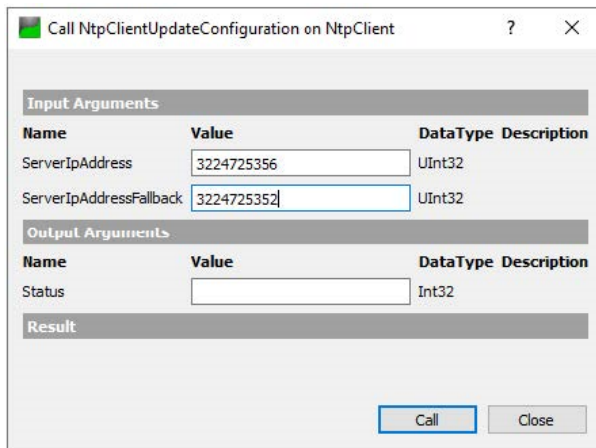

- In the **Input Arguments** area, enter the value 3224725356 in the **ServerIpAddress** input field for the IP address of the NTP server.
- In the **Input Arguments** area, enter the number 3224725352 in the **ServerIpAddressFallback** input field for the IP address of the replacement NTP server.
- Click **Call**.

If the function call was successful, the output field to the right of Status in the **Output Arguments** area displays the value 0. A green bar with the text “Succeeded” is displayed in the **Result** area.

The two variables ServerIpAddress and ServerIpAddressFallback are now set. The device obtains the current time from the time server via NTP and synchronizes its internal time.

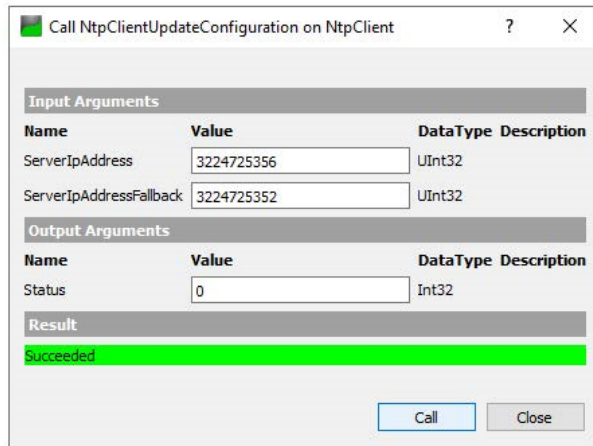

8.7 Object Directory

8.7.1 Setting the IO-Link Master

Digital IO Layout Configuration

Index	Name	Type	Access	Default-value	Meaning
0x2001	PD Layout Configuration	UNIT8	RW	0	0: Port-based 1: Pin-based



INFORMATION

After restarting the device, the changes to the web server settings take effect.

DO Substitute Configuration

Index	Name	Type	Access	Default-value	Meaning
0x2002:0	DO Substitute Configuration				
0x2002:0	Highest supported subindex	UNIT8	RO	1	
0x2002:1	DO Substitute Mode	UNIRT8	RW	0	0: Off 2: Hold last

8.7.2 Setting IO-Link Ports

Digital Ports IO-Link-Port Class A/B

Index	Name	Type
0x2100	Configuration Port X0 Parameters	RECORD
0x2110	Configuration Port X1 Parameters	
0x2120	Configuration Port X2 Parameters	
0x2130	Configuration Port X3 Parameters	
0x2140	Configuration Port X4 Parameters	
0x2150	Configuration Port X5 Parameters	
0x2160	Configuration Port X6 Parameters	
0x2170	Configuration Port X7 Parameters	



INFORMATION

Parameter 0x21n0 (n = Ports X0 ... X7).

Index	Name	Type	Access	Default value	Meaning
0x21n:00	Port Xn Parameters	UNIT8	RO	5	
0x21n:01	Pin 4 (C/Q)	BOOL	RW	FALSE	0x00 (0dec) Digital Input (NO) 0x01 (1dec) Digital Input inverted (NC)
0x21n:0.2	Digital input filter Pin 4 (C/Q)	UINT8	RW	0x00	0x00 (0dec) No filter 0x0A (10dec) 1ms filter 0x1E (30dec) 3ms filter 0x32 (50dec) 5ms filter 0x64 (100dec) 10ms filter 0x96 (150dec) 15ms filter
0x21n:0.3	Reserved	-	-	-	-
0x21n:0.4	Digital Mode Pin2 (I/Q)	UINT8	RW	0x04 (4dec)	0x00 (0dec) Digital Input (NO) 0x01 (1dec) Digital Input inverted (NC) 0x02 (2dec) Digital Output 0x03 (3dec) Static ON (24V) 0x04 (4dec) Deactivated
0x21n:0.5	Digital Input Filter Pin2 (I/Q)	UINT8	RW	0x0A (10dec)	0x00 (0dec) = No filter 0x0A (10dec) = 1 ms filter 0x1E (30dec) = 3 ms filter 0x32 (50dec) = 5 ms filter 0x64 (100dec) = 10 ms filter 0x96 (150dec) = 15 ms
0x21n:0.6	IO-Link Process Data Swap	UINT8	RW	0	0 = No Swap 1 = 16 Bit Swap In case of odd data length the last byte will not be touched 2 = 32 Bit Swap

Index	Name	Type	Access	Default value	Meaning
					In case the data length is not on 4 byte boundary <ul style="list-style-type: none"> • 3 byte, swap of byte x with x+2. x+1 will not be touched • 3 byte, swap of byte x with x+2. x+1 will not be touched • 1 byte, byte will not be touched 3 = Full Swap

8.7.3 Device Reset

Firmware Update

Index	Name	Type	Access	Default value	Meaning
0x5FFF	Reset to Factory	UNIT8	WO	-	1: Device Config 2: Network Config 3: Application Config 4: Factory reset

9 Operation

9.1 LED Display

The device has separate and clearly arranged displays:

- LED display for inputs and outputs
- LED display BUS
- LED display POWER
- Advanced LED displays

In order to assure unequivocal allocation of displayed information, the LEDs are correspondingly identified at the device's front panel. Displays include static illumination and blinking LEDs.

9.1.1 * Flashing Behavior:

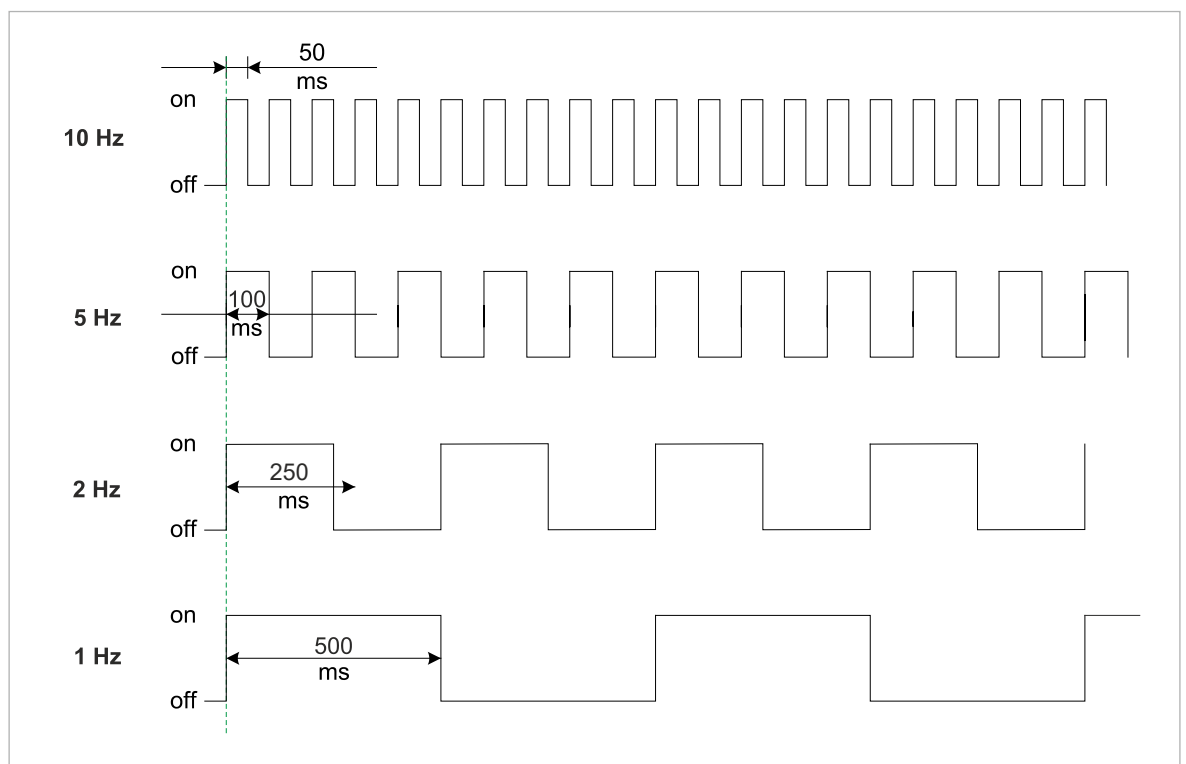

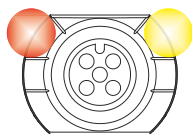

9.1.2 LED Display for Inputs and Outputs







A separate status display is assigned to each input and output.

Pin 2 Digital Input DI

Indicator	Status	Description
 Yellow	Continuous light	Fixed configuration: DI (NO) visible in process data. 24 V
	Flashing 1 Hz	Overload/short-circuit of the sensor supply

Indicator	Status	Description
Red		24 V + Pin 1
	Off	Pin 2 is not used or is switched off



Pin 2 Digital Output DO

Indicator	Status	Description
 Yellow	Continuous light	Fixed configuration: DO can be switched via process data 24 V
 Red	Continuous light	Overload/short circuit at pin 2
 Red	Flashing 1 Hz	Overload/short-circuit of the sensor supply 24 V + Pin 1
	Off	Pin 2 is not used or is switched off





Input or Output Error

If an error occurs on an input or output, the corresponding LED on the M12 slot lights up red.



Pin 4 Digital Input DI





Indicator	Status	Description
 Yellow	Continuous light	Fixed configuration: DI (NO) visible in process data 24 V
 Red	Flashing 1 Hz	Overload/short-circuit of the sensor supply 24 V + Pin 1
	Off	Pin 4 is not used or is switched off

Pin 4 Digital Output DO

Indicator	Status	Description
 Yellow	Continuous light	Fixed configuration: DO can be switched via process data 24 V
 Red	Continuous light	Overload/short circuit at pin 4
 Red	Flashing 1 Hz	Overload/short-circuit of the sensor supply 24 V + Pin 1
	Off	Pin 4 is not used or is switched off

Pin 4 IO-Link Mode

Indicator	Status	Description
 Green	Continuous light	IO-Link in status Operate.
 Green	Flashing 1 Hz	<ul style="list-style-type: none"> • Device is not connected • No communication with connected device.



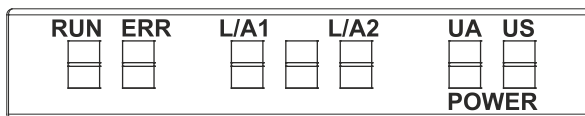

Indicator	Status	Description
 Green	Flashing 10 Hz	<ul style="list-style-type: none"> IO-Link in Pre-Operate status during data retention Validation failed. Incompatible IO-Link device connected.
 Red	Continuous light	Overload/short circuit at pin 4
 Red	Flashing 1 Hz	<ul style="list-style-type: none"> Validation failed. Incompatible IO-Link device connected for data storage. Data storage failed.
 Off	Off	IO-Link connection deactivated.

9.1.3 LED Display RUN_ERR



- RUN-LED shows the status of the bus system.

LED Display BUS_RUN





Indicator	Status	Description
 Green	Continuous light	Device in OPERATIONAL mode
 Green	Short flash long pause(single flash)	Device in SAFE-OPERATIONAL mode
 Green	Flashing 2.5 Hz	Device in PRE-OPERATIONAL mode
 Off	Off	Device in INIT mode

LED Flashing Green

You can do this:

Check the operating condition of the PLC.

LED Display ERR

Indicator	Status	Description
 Red	Flashing 2.5 Hz	Configuration error
 Red	Short flash long pause(single flash)	The slave device application has changed the EtherCAT status autonomously
 Red	Flash-flash pause (double flash)	Application watchdog timed out
 Off	Off	The device's EtherCAT communication is working

LED Display Red

You can do this:

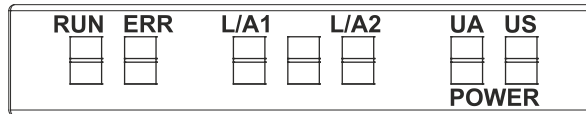

Check PLC configuration.

9.1.4 LED Display L/A1/LA2



- L/A1 and L/A2 (Link/Activity) show the status of the EtherCAT communication on the respective port.

LED Display L/A1 and L/A2

Indicator	Status	Description
 Green	Continuous light	The device <ul style="list-style-type: none"> • is connected to the EtherCAT network • does not send/receive EtherCAT frames
 Green	Flashing	The device <ul style="list-style-type: none"> • is connected to the EtherCAT network • sends/receives EtherCAT frames
 Off	Off	The device is not connected to the EtherCAT network.

LED Display Off





You can do this:

Check the cable connections.

9.1.5 LED Display Status

ST – indicates the status of the entire device.

LED Display ST

Indicator	Status	Description
 Green	Continuous light	The regular FW is running. Error-free operation.
 Green	Flashing 4 Hz	The process requested by the position of the rotary switch is carried out. Do not switch off the device.
 Red	Flashing 2 Hz	Invalid rotary switch position. The system will not start.
 Red	Continuous light	Initialization error. Error during device initialization. <ul style="list-style-type: none"> • HW problems, • No valid configuration, • No COM FW found • Rotary switch operation failed etc.

Red LED Flashes

You can do this:

- Select a valid position.
- Restart the device.



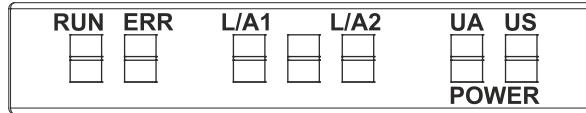

9.1.6 LED Display POWER US and UA







The Power LEDs Indicate the Status of the Supply Voltages

- UA actuator voltage
- US operating voltage LED display ST

LED Display POWER US

Indicator	Status	Description
 Green	Continuous light	$18\text{ V} \leq \text{US} \leq 30\text{ V}$ Error-free operation
 Red	Continuous light	$11\text{ V} \leq \text{US} \leq 18\text{ V}$ undervoltage
 Red	Flashing 4 Hz	$\text{US} > 30\text{ V}$ overvoltage
 Off	Off	$\text{US} < 11\text{ V}$ No voltage

LED Display POWER UA

Indicator	Status	Description
 Green	Continuous light	$18\text{ V} \leq \text{US} \leq 30\text{ V}$ Error-free operation
 Red	Continuous light	$11\text{ V} \leq \text{US} \leq 18\text{ V}$ undervoltage
 Red	Flashing 4 Hz	$\text{US} > 30\text{ V}$ overvoltage
 Off	Off	$\text{US} < 11\text{ V}$ No voltage



INFORMATION

At $\text{US} < 18\text{ V}$, fault-free operation is no longer guaranteed.

9.2 EtherCAT Diagnostic Messages

The object 0x10F3 is available for the diagnostics function. Up to 250 diagnostic messages can be stored there in a ring buffer.

All events that triggered a telegram in the device are recorded.

Possible Messages

EtherCAT system diagnostics generated by the IO-Link master:

- Information
- Warning
- Error

IO-Link events sent from the connected IO-Link device to the master.

In addition, a time stamp [ns] is left in object 0x10F8 "Timestamp Object" for each diagnostic message.

Emergency Telegrams

Emergency telegrams are messages that are actively sent from the device to the EtherCAT master in the event of certain events/problems. This is an unconfirmed, CoE-based service.

Device-Related Diagnostic Messages

Error identifier	EtherCAT Diag Code	EtherCAT Emergency (5 Bytes)	Meaning
0x0100	0xFF00E800	0x0X, 0x00, 0x00, 0x01,0x00	Undervoltage Us
0x0101	0xFF01E800	0x0X, 0x00, 0x00, 0x01,0x01	Overvoltage Us
0x0102	0xFF02E800	0x0X, 0x00, 0x00, 0x01,0x02	Overtemperature
0x0103	0xFF03E800	0x0X, 0x00, 0x00, 0x01,0x03	Overload at Us
0x0104	0xFF04E800	0x0X, 0x00, 0x00, 0x01,0x04	Overload at Ua
0x0105	0xFF05E800	0x0X, 0x00, 0x00, 0x01,0x05	Undertemperature
0x0106	0xFF06E800	0x0X, 0x00, 0x00, 0x01,0x06	Undervoltage Ua
0x0107	0xFF07E800	0x0X, 0x00, 0x00, 0x01,0x07	Overvoltage Ua
0x0108	0xFF08E800	0x0X, 0x00, 0x00, 0x01,0x08	Force mode active



INFORMATION

EtherCAT telegram: First byte is:

- 0x00 for the occurring diagnoses and
- 0x01 for disappearing diagnoses.

Port-Related Diagnostic Messages

Error identifier	EtherCAT Diag Code	EtherCAT Emergency (5 Bytes)	Text ID	Meaning
0x1800	0x0001E002	0xE0, 0x02, 0xFF, 0x18, 0x00	0x002C	No device (communication)
0x1801		0xE0, 0x02, 0xFF, 0x18, 0x01	0x0001	Startup parameterization error
0x1802		0xE0, 0x02, 0xFF, 0x18, 0x02	0x0002	Incorrect Vendor ID
0x1803		0xE0, 0x02, 0xFF, 0x18, 0x03	0x0003	Incorrect DeviceID
0x1804		0xE0, 0x02, 0xFF, 0x18, 0x04	0x0004	Short circuit at pin 4 (IOL)
0x1805		0xE0, 0x02, 0xFF, 0x18, 0x05	0x0005	Overtemperature
0x1806		0xE0, 0x02, 0xFF, 0x18, 0x06	0x0006	Short circuit at pin 1
0x1807		0xE0, 0x02, 0xFF, 0x18, 0x07	0x0007	Overcurrent at pin 1
0x1808		0xE0, 0x02, 0xFF, 0x18, 0x08	0x0008	Device Event overflow
0x1809		0xE0, 0x02, 0xFF, 0x18, 0x09	0x0009	Backup inconsistency – memory out of range

Error identifier	EtherCAT Diag Code	EtherCAT Emergency (5 Bytes)	Text ID	Meaning
0x180A		0xE0, 0x02, 0xFF, 0x18, 0x0A	0x000A	Backup inconsistency – identity fault
0x180B		0xE0, 0x02, 0xFF, 0x18, 0x0B	0x000B	Backup inconsistency – Data storage error
0x180C		0xE0, 0x02, 0xFF, 0x18, 0x0C	0x000C	Backup inconsistency – upload fault
0x180D		0xE0, 0x02, 0xFF, 0x18, 0x0D	0x000D	Backup inconsistency – download fault
0x180E		0xE0, 0x02, 0xFF, 0x18, 0x0E	0x000E	Class B power (pin 2) missing or undervoltage
0x180F		0xE0, 0x02, 0xFF, 0x18, 0x0F	0x000F	Class B power (pin 2) short circuit
0x1810		0xE0, 0x02, 0xFF, 0x18, 0x10	0x0010	Short circuit at pin 2
0x1811		0xE0, 0x02, 0xFF, 0x18, 0x11	0x0011	Short circuit at pin 4 (digital out)
0x1812		0xE0, 0x02, 0xFF, 0x18, 0x12	0x0012	Overcurrent at pin 2
0x1813		0xE0, 0x02, 0xFF, 0x18, 0x13	0x0013	Overcurrent at pin 4 (digital out)
0x6000		0xE0, 0x02, 0xFF, 0x60, 0x00	0x0014	Invalid cycle time
0x6001		0xE0, 0x02, 0xFF, 0x60, 0x01	0x0015	Revision error – incompatible protocol version
0x6002		0xE0, 0x02, 0xFF, 0x60, 0x02	0x0016	ISDU batch failed
0xFF26		0xE0, 0x02, 0xFF, 0x60, 0x26	0x0017	Port status changed – Use "SMI_PortStatus" service for port status in detail
0xFF27		0xE0, 0x02, 0xFF, 0x60, 0x27	0x0018	Data Storage upload completed and new data object available
0xFF31		0xE0, 0x02, 0xFF, 0x60, 0x31	0x0019	DL: Incorrect Event signaling



INFORMATION

EtherCAT telegram structure:

- 0xE002 + port number + error code for occurring diagnoses,
- 0x0000 + port number + error code for disappearing diagnoses.

10 Web Server

The wenglor web server is a graphical tool with which you can quickly and intuitively obtain information about the device.

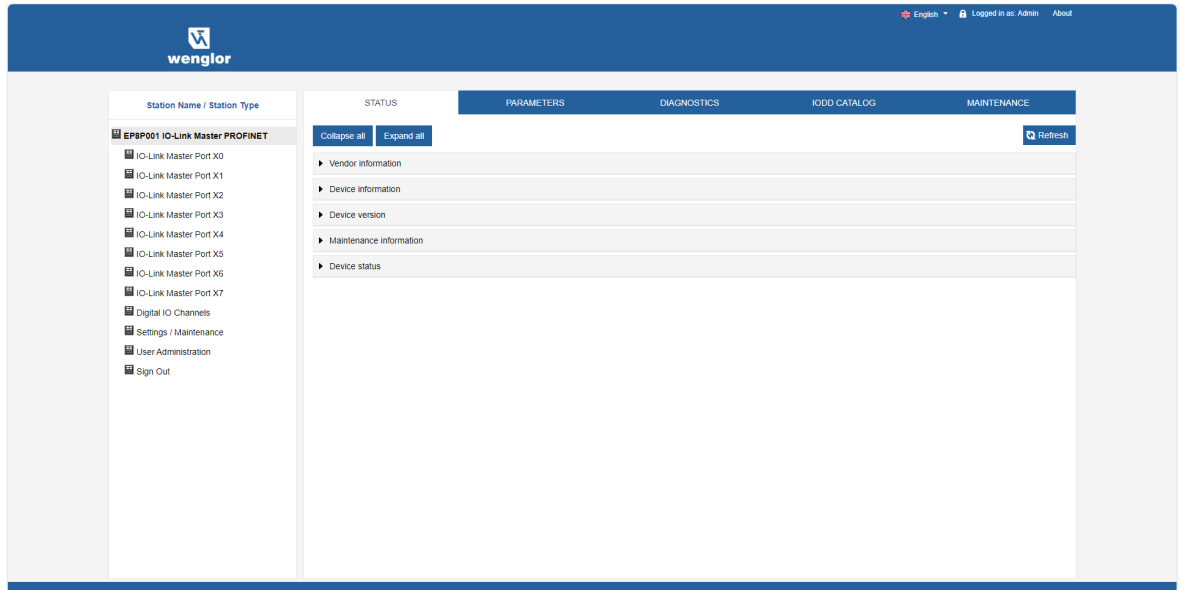

The devices mentioned in the screenshots serve as examples.

10.1 Start Web Server

Prerequisites

Prerequisite for a correct graphical representation of the web server:

The following browsers with HTML5 and ES5 are supported by:

- Mozilla Firefox
- Microsoft Edge
- Google Chrome

To start the web server, proceed as follows:

- Start the web browser.
- Enter the IP address of the device in the web browser. The start screen of the web server is displayed.

10.2 Access and Login

Username and Password

Username and password at first startup

1. At first start-up, enter the login details for user name and password:

- a) User name <admin>
- b) Password <private>

Second Click on Login.

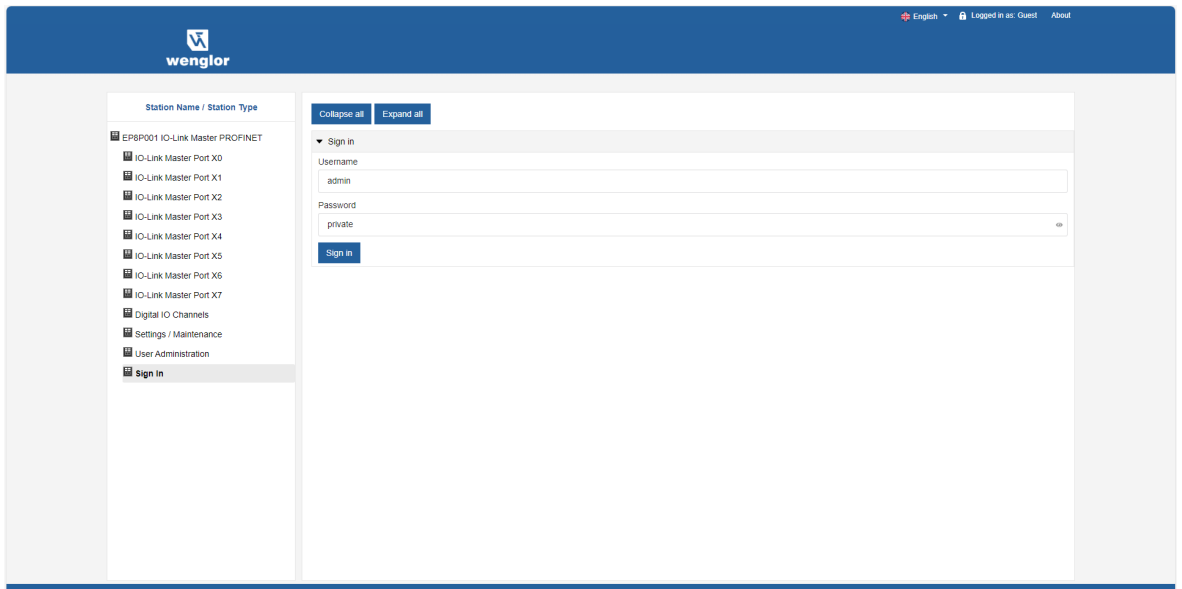

Change Password



INFORMATION

Ensure data security.

→ Change user name and password after the first login and after each factory reset.

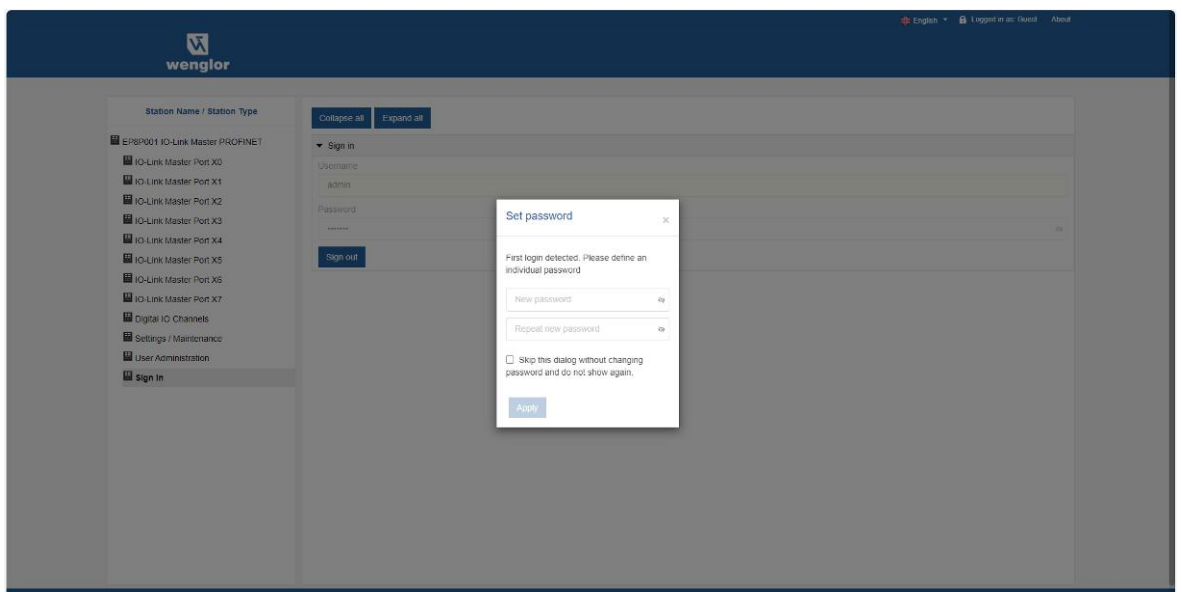

10.3 Start Screen

Operating Ranges

The web server is divided into 4 operating areas.

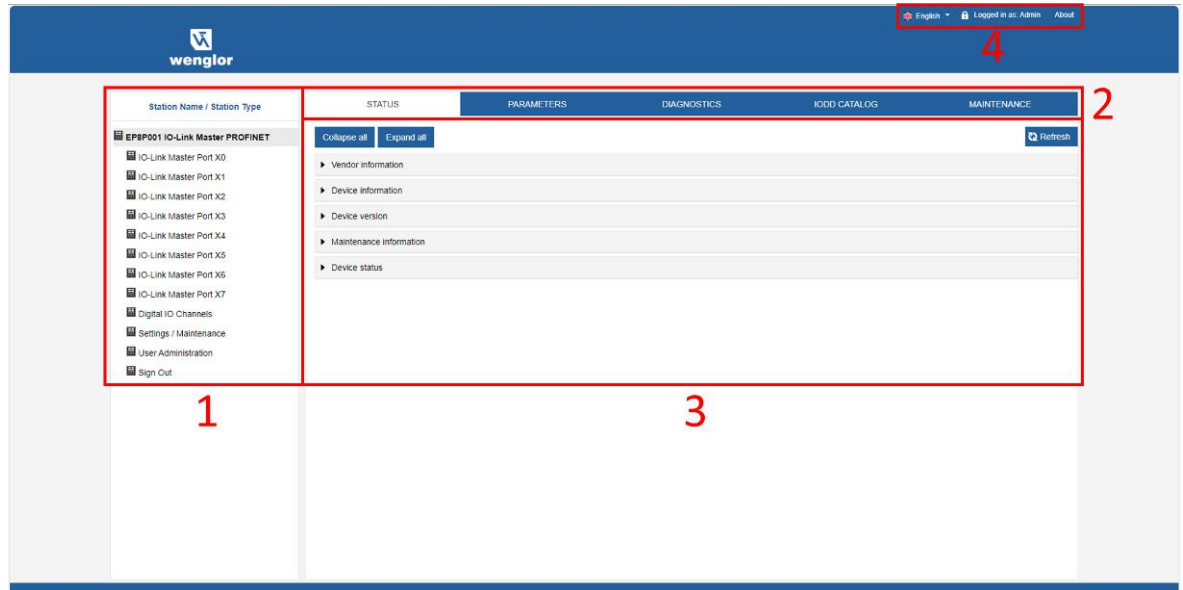

1. **System tree**

This shows the device and available sub-functions.

2. **Menu bar**

The menu bar can be used to switch between the different pages of the device or the subfunction. In addition, the white highlighting shows which page you are currently on.

3. **Page content**

This area displays the content of the selected page.

4. **Header bar**

Language and interface settings, system information.

10.4 Menu Bar

The first line of the system tree displays the device with article number and product name.

The menu bar contains the following clickable menu items:

- STATUS
- PARAMETER
- DIAGNOSTICS
- IODD CATALOG
- MAINTENANCE

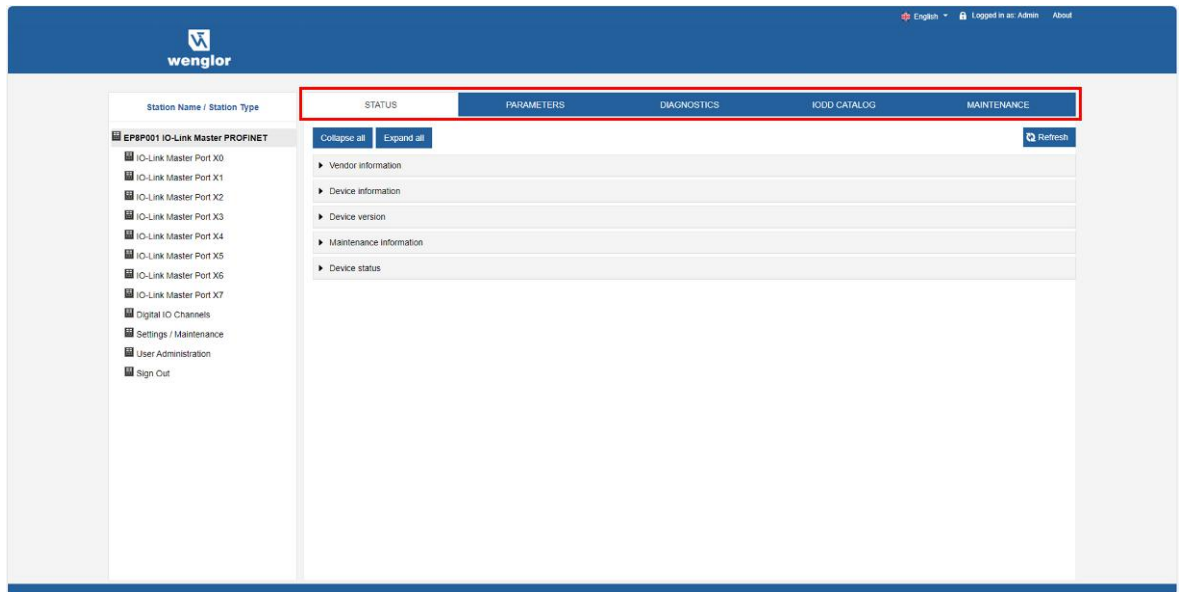

10.4.1 STATUS Menu

The “Status” menu item contains the following sub-items:

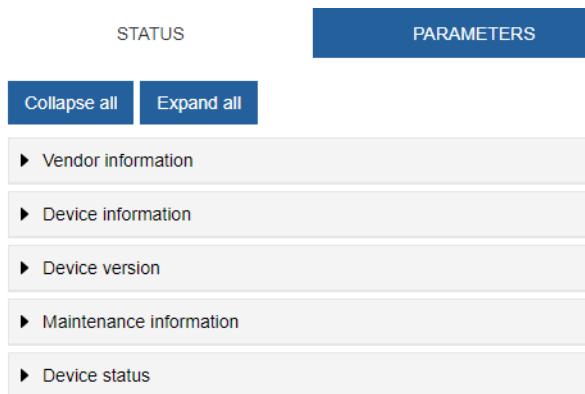

Manufacturer Information

“Manufacturer information” shows the following information:

Parameter name	Meaning
Manufacturer name	Fixed manufacturer data
Manufacturer address	Fixed manufacturer data
Manufacturer phone	Fixed manufacturer data
Manufacturer URL	Manufacturer website

Device Information

“Device information” displays the following information:

Parameter name	Meaning
Order Number	Article number of the device
Hardware name	Fixed article designation of the device
Software name	Device fieldbus designation
Software number	Serial number of the device

Device Version

“Device version” shows the following information:

Parameter name	Meaning
Hardware version	Version of hardware
Software version	Current software version in the device
Website version	Current version of the web server in the device

Maintenance Information



INFORMATION

The maintenance information can only be read here. The fields are entered or changed via “Settings/Maintenance → Maintenance information”.

“Maintenance information” displays the following information:

Parameter name	Meaning
Name	Device name, free text
Installation location	Place name, free text
Contact information	Contact, free text
Description	Description, free text
Last maintenance date (yyyy-mm-dd)	Free date entry
Next maintenance date (yyyy-mm-dd)	Free date entry

IO-Link Device Information

Parameter name	Meaning
1L voltage [V]	Display of sensor voltage in volts
1L current [A]	Display of sensor voltage in amperes
2L voltage [V]	Display of sensor voltage in volts
2L current [A]	Display of sensor voltage in amperes
Temperature [°C]	Display of the device temperature in Celsius
Total operating time [hh:mm:ss] Number of starts	Operating time since the device was switched on
Number of starts	Number of device restarts

10.4.2 PARAMETERS Menu

The “Parameters” menu item contains the following sub-items:

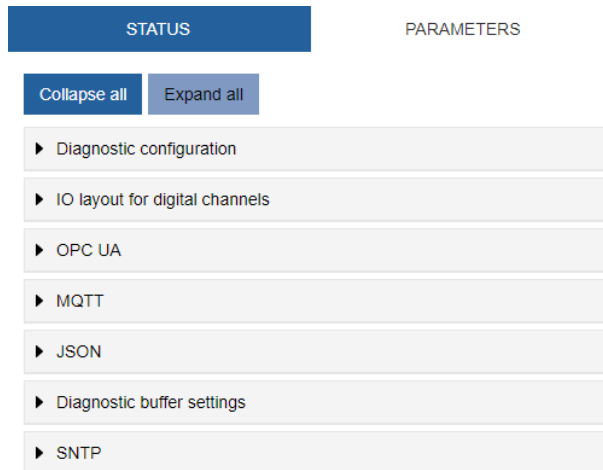

OPC UA

Users with Admin and Operator rights can change settings and enter the OPC UA port number. Guest users have read access.

OPC UA displays the following information:

Parameter name	Meaning
Enable OPC UA Server	OPC-UA server on the module active/passive
Allow OPC UA clients to write ISDU data	OPC-UA client may write ISDU data (Indexed Service Data Unit) to the module on the IO-Link master
Allow OPC UA clients to write PDO data	OPC-UA client is allowed to write PDO (process data objects) to the assembly on the IO-Link master
OPC UA port number	Display/definition of OPC-UA port

MQTT

Users with admin and operator rights can change settings and enter the IP address of the MQTT server. Guest users have read access.

“MQTT” shows the following information:

Parameter name	Meaning
Activate MQTT	MQTT client on the assembly active/passive
MQTT server IP address	IP address of the MQTT server
MQTT Client ID	Read/Write MQTT Client ID
Client head topic	Reading/writing an MQTT topic
Topic for system	Reading/writing an MQTT topic

JSON

Users with admin and operator rights can enable and disable JSON. Guest users have read access.

“JSON” shows the following information:

Parameter name	Meaning
Activate JSON	JSON interface on the module active/passive

10.4.3 DIAGNOSTICS

The “Diagnostics” menu item displays the incoming and outgoing alarms of the master.

The menu shows an overview of the diagnostic messages.

Depending on the setting in the “Please select an entry” drop-down menu, the following diagnostics of the device are displayed:

- Enabled
- All diagnoses pending at the time of the web server call.
- All diagnoses that no longer exist are not displayed.
- History
- All diagnoses no longer available from the residual diagnostic memory are displayed.
- More than 40 diagnoses in memory. The latest diagnostics overwrites the oldest in the memory.

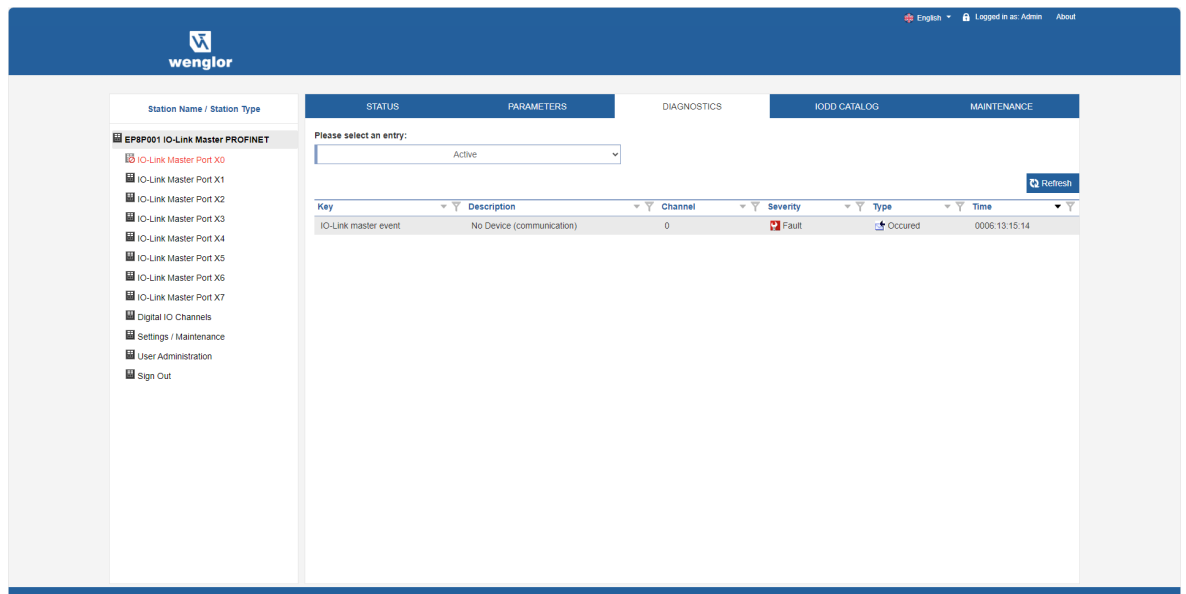

The screenshot displays the Wenglor web interface. The top navigation bar includes the Wenglor logo and user information (English, Logged in as: Admin, About). The main content area is divided into several tabs: STATUS, PARAMETERS, DIAGNOSTICS (selected), IODD CATALOG, and MAINTENANCE. On the left, a sidebar lists various station components under the heading "EP8P001 IO-Link Master PROFINET", including IO-Link Master Port X0 through X7, Digital IO Channels, Settings / Maintenance, User Administration, and Sign Out. The main content area features a dropdown menu labeled "Please select an entry:" with "Active" selected. Below this is a table with columns: Key, Description, Channel, Severity, Type, and Time. A single entry is visible: "IO-Link master event" with description "No Device (communication)", channel "0", severity "Fault", type "Occurred", and time "0006 13:15:14". A "Refresh" button is located in the top right corner of the table area.

10.4.4 IODD CATALOG Menu

In the “IODD CATALOG” menu item, users can manage the IODD files on the device.

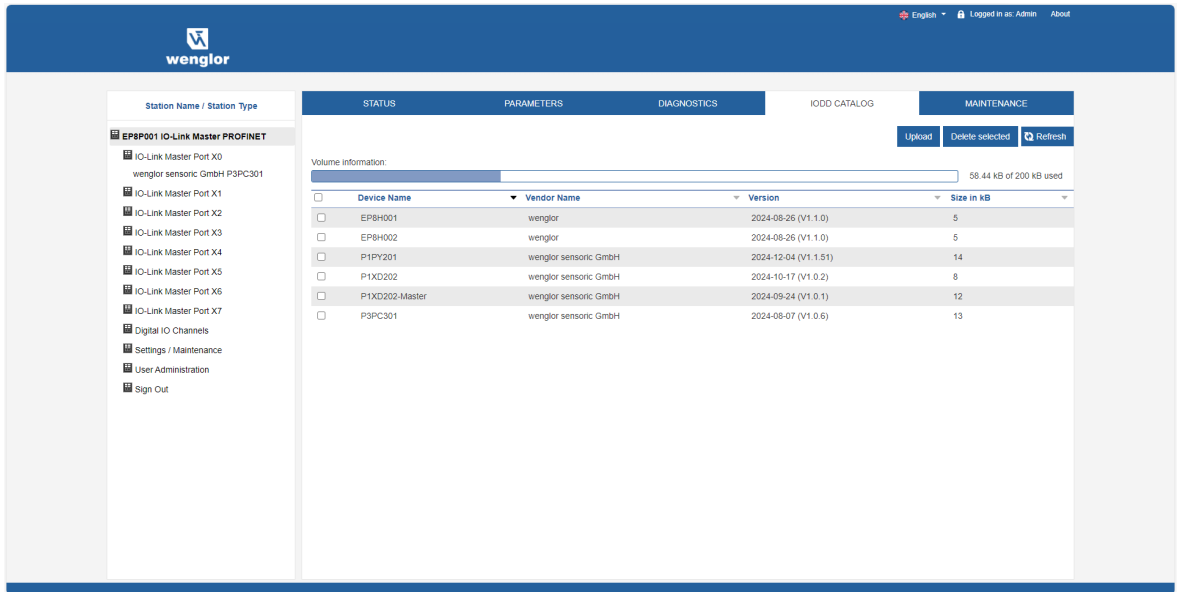

10.4.5 MAINTENANCE Menu

Users with administrator and operator rights can delete the diagnostic memory in the “Maintenance” menu item.

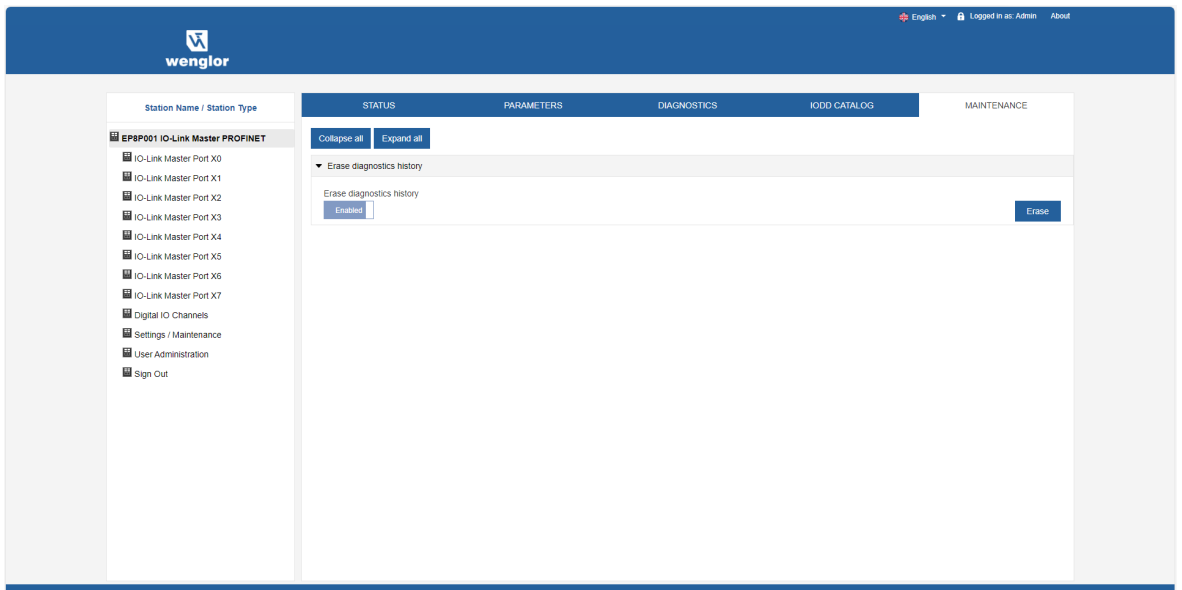

10.5 IO-Link Master Port

The system tree displays 8 IO-Link master ports (X0 ... X7), which can be selected individually. Depending on the user role, information can be read or functions configured here. When IO-Link communication is active, the IO-Link device name automatically appears under the relevant port.

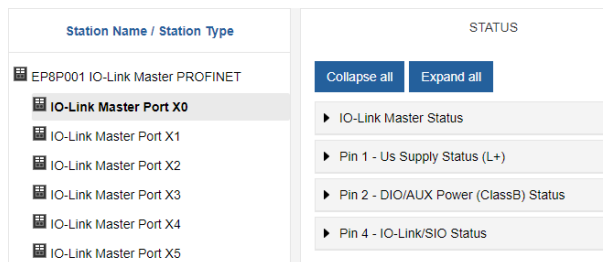

10.5.1 STATUS Menu

The IO-Link master status is displayed here in the Status menu.

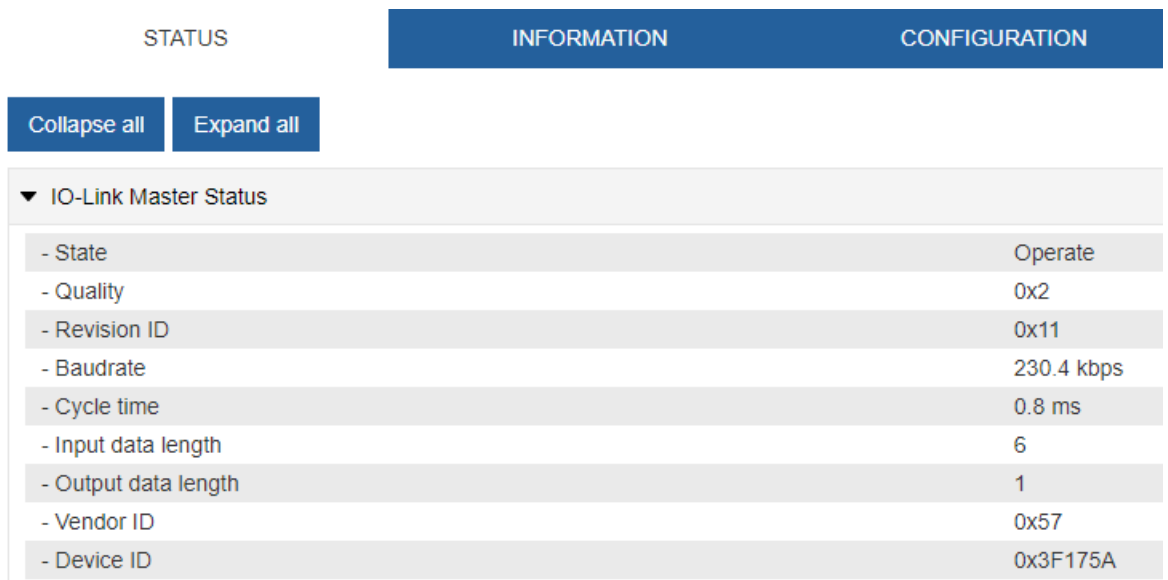

If pin 4 is in IO-Link mode, all relevant IO-Link data including the I/O bytes of the device are displayed (see Fig. 10-10: "IO-Link Master Port – IO-Link Master Status").

If pin 4 is in operation without an IO-Link device connected, it is displayed that no device is connected.

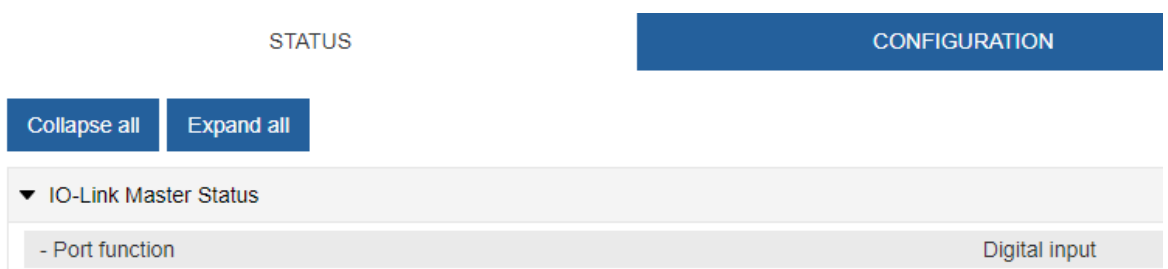

For example, if pin 4 is configured as a digital input, this is also displayed here (see Fig. 10-11: "IO-Link master port – IO-Link master status in digital mode").

Possible status displays:

- Status: Deactivated
- Status: Digital input
- Status: Digital output

Port Status – Pin 1

“Port Status – Pin 1” displays the following information

Parameter name	Meaning
Temperature [°C]	Temperature in degrees Celsius
Voltage [V]	Voltage in volts
Current [A]	Current in amps
Status	Status of pin

Port Status – Pin 2

“Port Status – Pin 2” displays the following information

Parameter name	Meaning
Temperature [°C]	Temperature in degrees Celsius
Voltage [V]	Voltage in volts
Current [A]	Current in amps
Status	Status of pin

Port Status – Pin 4

“Port Status – Pin 4” displays the following information

Parameter name	Meaning
Temperature [°C]	Temperature in degrees Celsius
Voltage [V]	Voltage in volts
Current [A]	Current in amps
Status	Status of pin

10.5.2 INFORMATION Menu

The “Information” menu item contains the following sub-items:

STATUS
INFORMATION
CONFIGURATION
IO-LINK PARAMETERS

Collapse all
Expand all

▼ IO-Link Device Information

- Min cycle time	0.8 ms
- Function ID	0
- Number of profile IDs	4
- Vendor name	wenglor sensoric GmbH
- Vendor text	the innovative family
- Product name	P3PC301
- Product ID	P3PC301
- Product text	Laser Distance Sensor Triangulation
- Serial number	750073271
- Hardware revision	V01.00.00
- Firmware revision	V01.00.00

IO-Link Device Information

The technical data and manufacturer information of a connected and active IO-Link device on the corresponding master port are displayed here.

“IO-Link Device Information” displays the following information:

Parameter name	Meaning
Min. cycle time	Minimum process cycle time of the IO-Link device
Function-ID	Function ID of the IO-Link device
Number of profile IDs	Number of profiles supported by the IO-Link device
Manufacturer name	Manufacturer name of the IO-Link device
Manufacturer text	Manufacturer text of the IO-Link device
Product name	Product name of the IO-Link device
Product ID	Article number of the IO-Link device
Product text	Additional description of the IO-Link device
Serial number	Serial number
Hardware status	Hardware status
Firmware status	Firmware status

10.5.3 CONFIGURATION Menu

In the “Configuration” menu item of the selected IO-Link port, the setting of pin 1, pin 2 and pin 4 on the selected port is displayed and can be configured there.

Users with Operator and Admin rights can set the functions and behavior of Pin 1, Pin 2 and Pin 4.

Users with service and maintenance rights have read access.

Pin 4 can be deactivated or configured as IO-Link master, input or output.

The screenshot shows the configuration interface for an IO-Link port. At the top, there are four tabs: STATUS, INFORMATION, CONFIGURATION (selected), and IO-LINK PARAMETERS. Below the tabs are two buttons: 'Collapse all' and 'Expand all'. The main content area is a list of port functions. The 'Port Functions - Pin 4' section is expanded, showing a dropdown menu for 'Port function' with the following options: IO-Link autostart, Deactivated, IO-Link manual configuration, IO-Link autostart (highlighted), Digital Input, normally open, Digital Input, normally closed, and Digital output. Below this, there are sections for 'Port Functions - Pin 2', 'Port Functions - Pin 1', 'Port Diagnostics', and 'IO-Link Assignment'.

Pin 2 can be deactivated or configured as input, output or DIO in “Automatic Mode”.

STATUS	CONFIGURATION	PROCESS DATA
Collapse all	Expand all	Save Refresh
▶ Port Functions - Pin 4		
▼ Port Functions - Pin 2		
Port function	Automatic mode (DIO) ▼	
Digital input signal filter	No digital input filter ▼	
Output current limitation for DIO	2.0 A ▼	
▶ Port Functions - Pin 1		
▶ Port Diagnostics		
▶ IODD Assignment		

If pin 2 or pin 4 is configured as an input, the digital input filters can be set individually.

STATUS	CONFIGURATION	PROCESS DATA
Collapse all	Expand all	Save Refresh
▶ Port Functions - Pin 4		
▼ Port Functions - Pin 2		
Port function	Automatic mode (DIO) ▼	
Digital input signal filter	No digital input filter ▼	
Output current limitation for DIO	No digital input filter 1ms 3ms 5ms 10ms 15ms	
▶ Port Functions - Pin 1		
▶ Port Diagnostics		
▶ IODD Assignment		

10.5.4 IO-LINK PARAMETERS Menu

This menu item can be used to read and write the ISDU (Index Service Data Unit) of the device during IO-Link operation. This primarily allows an IO-Link device to be evaluated or parameterized without a control system. The input can be made in both Hex and ASCII format.



INFORMATION

Follow the instructions in the IO-Link device manufacturer's manual.

Users with maintenance and admin rights can write ISDU values. Users with service rights have read access.

STATUS	INFORMATION	CONFIGURATION	IO-LINK PARAMETERS	PROCESS DATA
Collapse all	Expand all		Save Refresh	
▼ ISDU Communication				
Index			00	
Subindex			00	
Input data			00	
Format			Hex ▼	
Read Write				
<small>* All values are in hexadecimal without spaces.</small>				
Clear history				

10.5.5 PROCESS DATA Menu

In the “Process data” menu item, the current process data of the connected IO-Link device is displayed continuously if pin 4 of the corresponding port has been configured as an IOL port. Example: Port X2: Pin 4 (IOLink Autostart) and Pin 2 (Digital output static on).

STATUS	INFORMATION	CONFIGURATION	IO-LINK PARAMETERS	PROCESS DATA
Collapse all Expand all				
▼ Process Data				
Pin 4 IOL Input				00,07,0b,d0,fa,03
Pin 4 IOL Output				00
Force Pin 4 IOL Output Data			Write Disable Forcing	0
Pin 2 DO				1
Pin 2 DI				1
Format				Hexadecimal

This menu item displays the current statuses of the digital inputs. Example: Port X1: Pin 4 (DI) and Pin 2 (DI)

STATUS	CONFIGURATION	PROCESS DATA
Collapse all Expand all		
▼ Process Data		
Pin 4 DI		1
Pin 2 DO		1
Pin 2 DI		1
Format		Hexadecimal

10.6 Digital IO Channels / IO Overview

In the “Configuration” menu of the selected IO-Link port, the setting of pin 2 and pin 4 on the selected port is displayed. Outputs can be set under certain conditions.

10.6.1 Input Data

Each user can observe the digital states of the inputs configured on the device.

IO OVERVIEW	
Collapse all Expand all	
▼ Input data	
Port X1 Pin 4 (Channel 01)	Enabled
Port X2 Pin 4 (Channel 02)	Enabled
Port X3 Pin 4 (Channel 03)	Enabled
Port X4 Pin 4 (Channel 04)	Enabled
▶ Allow forcing outputs	
▶ Output data	

10.6.2 Output Data

Allow Outputs Setting

Users with Admin, Service and Maintenance rights can allow setting of outputs in this menu.

The right is only granted if the device is not in an active fieldbus connection with the control. The control has priority.

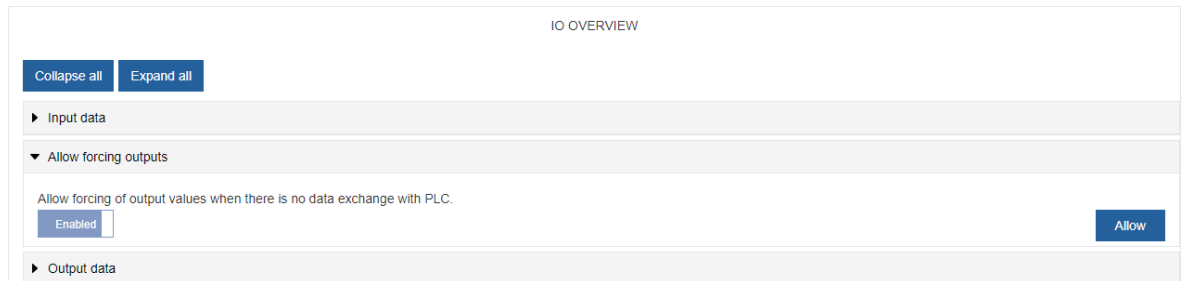

The screenshot shows the 'IO OVERVIEW' page with a 'Collapse all' and 'Expand all' button at the top. Under the 'Allow forcing outputs' section, there is a text label 'Allow forcing of output values when there is no data exchange with PLC.' and a toggle switch currently set to 'Enabled'. An 'Allow' button is located to the right of the toggle.

Setting of Output Data

Guest users are not allowed to set the outputs.

All other users (admin, operator, maintenance) are allowed to set the outputs.

As soon as the user (admin, operator, maintenance) logs out, the outputs go to "0".

As soon as a fieldbus is actively working with the device, the outputs go to "0" and then assume the status that they receive from the controller.

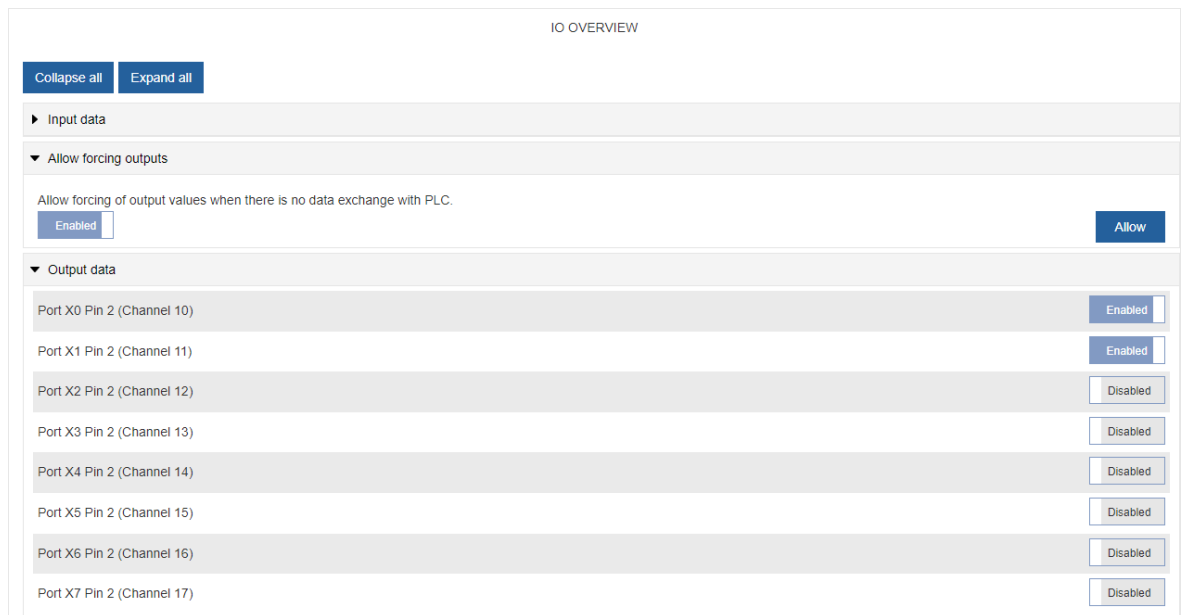

The screenshot shows the 'IO OVERVIEW' page with a 'Collapse all' and 'Expand all' button at the top. Under the 'Output data' section, there is a list of channels with their status:

Channel	Status
Port X0 Pin 2 (Channel 10)	Enabled
Port X1 Pin 2 (Channel 11)	Enabled
Port X2 Pin 2 (Channel 12)	Disabled
Port X3 Pin 2 (Channel 13)	Disabled
Port X4 Pin 2 (Channel 14)	Disabled
Port X5 Pin 2 (Channel 15)	Disabled
Port X6 Pin 2 (Channel 16)	Disabled
Port X7 Pin 2 (Channel 17)	Disabled

10.7 Settings / Maintenance

10.7.1 MAINTENANCE INFORMATION Menu

The maintenance information appears in the device in the menu item “Status” and submenu “Maintenance information”.

The screenshot shows the 'MAINTENANCE' tab selected in a navigation bar. Below the navigation bar are buttons for 'Collapse all', 'Expand all', and 'Refresh'. The main content area is a list of expandable sections: 'Vendor information', 'Device information', 'Device version', 'Maintenance information' (expanded), and 'Device status'. The 'Maintenance information' section contains a table with the following data:

- Name	EP18P001-23
- Installation location	G4P1
- Contact information	
- Description	IO-Link Master
- Last service date (yyyy-mm-dd)	2024-12-03
- Next service date (yyyy-mm-dd)	2025-12-03

Users with service, maintenance and admin rights can enter information about the device here.

The screenshot shows the 'MAINTENANCE INFORMATION' tab selected in a navigation bar. Below the navigation bar are buttons for 'Collapse all', 'Expand all', and 'Refresh'. The main content area is a form for editing maintenance information. The form has the following fields:

- Name: EP18P001-23
- Installation location: G4P1
- Installation date (yyyy-mm-dd): 2024-12-03
- Contact information: (empty)
- Description: IO-Link Master
- Last service date (yyyy-mm-dd): 2024-12-03
- Next service date (yyyy-mm-dd): 2025-12-03

An 'Apply' button is located at the bottom left of the form.

10.7.2 FIRMWARE Menu

This menu item displays the data of the firmware running on the device.

Users with service, maintenance and admin rights can install new firmware on the device here, provided in ZIP folders. After successful loading, the device checks the firmware container and starts automatically with the new firmware version.

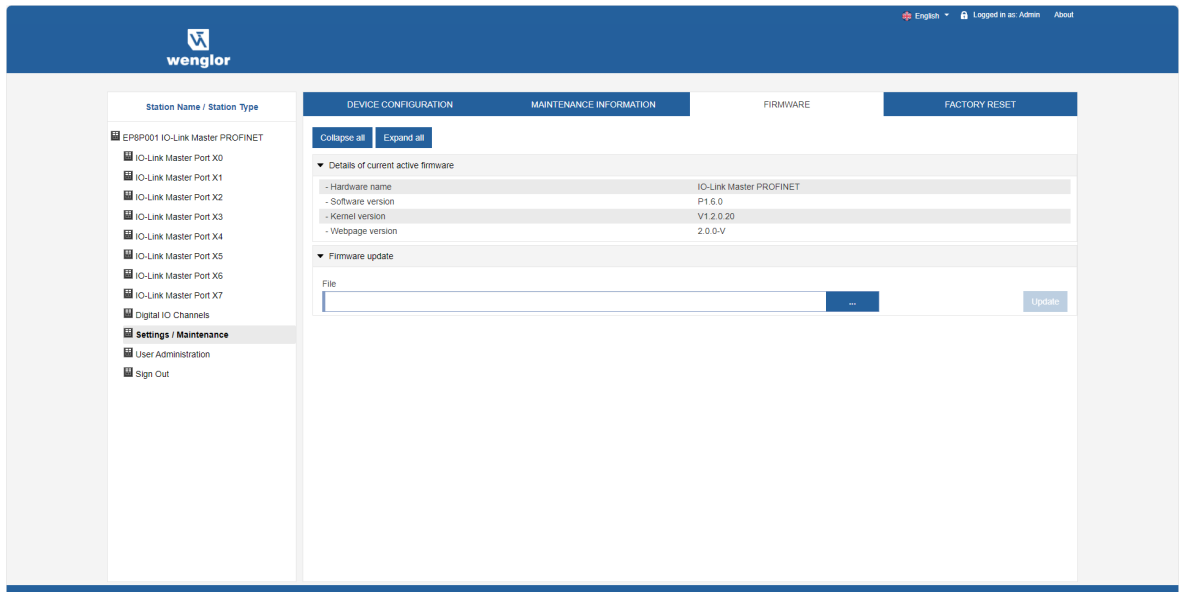

10.7.3 FACTORY RESET Menu

In this menu item, users with service, maintenance and admin rights can reset the entire device or individual sub-areas (device information, network, application).

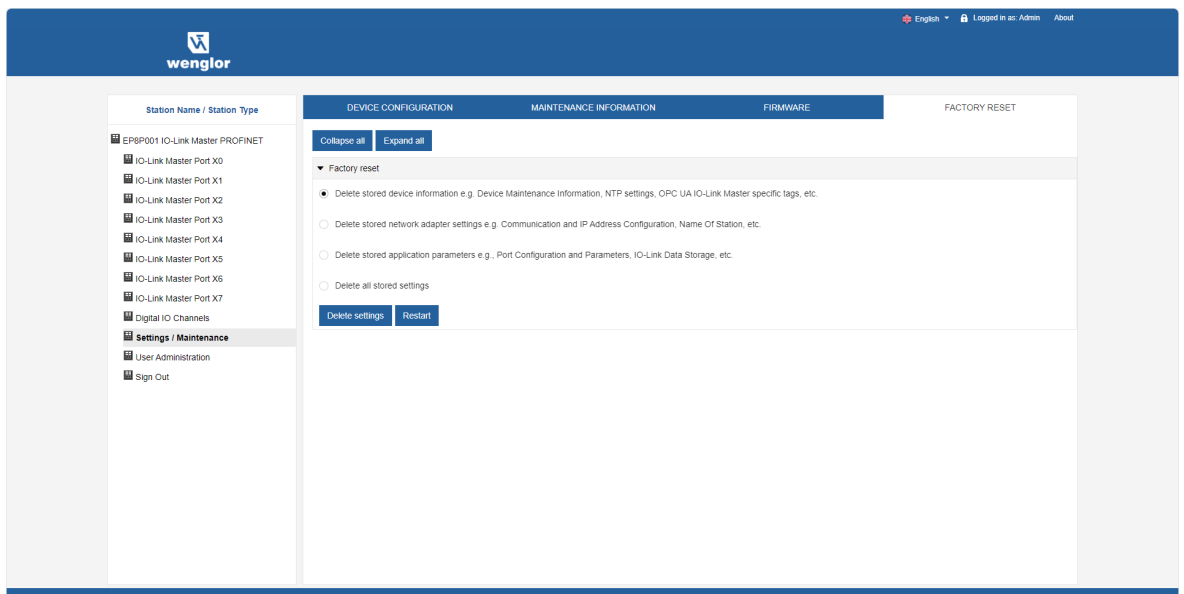

10.8 User Management

User administration can only be carried out with admin rights. Additional users with different user roles can be created here.

The administrator default password can be changed in the system with the fieldbus running from the controller.

Users log on and off in the system tree:

- Click on Logout.

English | Logged in as: Admin | About



Station Name / Station Type

- EP8P001 IO-Link Master PROFINET
- IO-Link Master Port X0
- IO-Link Master Port X1
- IO-Link Master Port X2
- IO-Link Master Port X3
- IO-Link Master Port X4
- IO-Link Master Port X5
- IO-Link Master Port X6
- IO-Link Master Port X7
- Digital IO Channels
- Settings / Maintenance
- User Administration**
- Sign Out

USER ADMINISTRATION

Collapse all
Expand all

▼ User list

Username	Userrole	Actions
admin	Admin	✖ ✔
maintenance	Maintenance	✖ ✔
operations	Operator	✖ ✔

▼ Add new user

Username Username	Password Password	Userrole Maintenance	Actions ✔
----------------------	----------------------	-------------------------	---

11 Maintenance Instructions



NOTICE

This wenglor product is maintenance-free.

Cleaning and inspection of the plug connections at regular intervals are advisable.

Do not clean the product with solvents or cleaning agents that could damage the product.

The product must be protected against contamination during initial start-up.

12 Proper Disposal

wenglor sensoric GmbH does not accept the return of unusable or irreparable products. Respectively valid national waste disposal regulations apply to product disposal.

13 **Declarations of Conformity**

Declarations of conformity can be found on our website at www.wenglor.com in the product's separate download area.