

# Operating Instructions

## **EP8P001**

### **IO-Link Master PROFINET**



EN



# Table of Contents

<b>1</b>	<b>General</b> .....	<b>5</b>
1.1	Information Concerning these Instructions .....	5
1.2	Explanation of Symbols .....	5
1.3	Limitation of Liability .....	6
1.4	Copyrights .....	6
<b>2</b>	<b>For Your Safety</b> .....	<b>7</b>
2.1	General Safety Instructions .....	7
2.2	Use for Intended Purpose .....	8
<b>3</b>	<b>Description</b> .....	<b>9</b>
3.1	Device .....	9
3.1.1	Device Configuration .....	10
3.1.2	Pin Assignments .....	11
3.1.3	Display Units .....	12
<b>4</b>	<b>Technical Data</b> .....	<b>13</b>
4.1	Electrical data .....	13
4.2	Ambient Conditions .....	16
4.3	Protection .....	17
4.4	Mechanical Data .....	17
4.5	Conformity, Approvals .....	17
4.6	Used IP Ports .....	18
<b>5</b>	<b>Installation</b> .....	<b>19</b>
5.1	Prerequisites .....	19
5.2	Dimensions .....	19
5.3	Mounting Clearance .....	20
5.4	Installation of the Unit .....	20
5.5	Functional Earth .....	22
5.6	Addressing Cover .....	22
<b>6</b>	<b>Installation</b> .....	<b>23</b>
6.1	Installing the Unit Electrically .....	23
6.1.1	Adjusting the Rotary Switch .....	24
6.1.2	Sensors and Actuators .....	26
6.1.3	PROFINET IO Communication .....	27
6.1.4	Power Supply .....	27
6.2	Ensure Tightness (IP67) .....	28
<b>7</b>	<b>Initial Start-Up</b> .....	<b>29</b>
7.1	Reading In the GSDML Files .....	29
<b>8</b>	<b>Configuration/Setting</b> .....	<b>31</b>
8.1	Changing the Configuration .....	31
8.2	Configuration Module .....	31
8.2.1	Slots .....	31
8.2.2	Module EP8P001 Device .....	32
8.2.3	Module EP8P001 options .....	36
8.2.4	Addresses .....	38
8.3	Module Parameterization .....	39
8.3.1	Module EP8P001 Device .....	39
8.3.2	Module EP8P001 options .....	52

8.4	IO-Link Configuration.....	57
8.5	Cyclic and Acyclic Communication.....	57
8.5.1	IO-Link Acyclic Accesses .....	58
8.5.2	I&M Data .....	58
8.5.3	IO-Link Function Block.....	60
8.6	Default Setting .....	64
8.6.1	Topology.....	64
8.6.2	PROFINET Device Name.....	67
8.6.3	Factory settings.....	69
8.7	Media Redundancy Protocol (MRP) Configuration .....	71
8.8	Isochronous Real Time (IRT) Configuration .....	73
8.9	Simple Network Management Protocol (SNMP).....	75
8.10	Industrial Internet of Things (IIoT).....	76
8.10.1	JSON .....	76
8.10.2	MQTT .....	78
8.10.3	OPC UA .....	80
<b>9</b>	<b>Operation.....</b>	<b>95</b>
9.1	LED Display .....	95
9.1.1	LED Assignment to Channel and Pin.....	95
9.1.2	* Flashing Behavior: .....	96
9.1.3	LED Display for Inputs and Outputs.....	96
9.1.4	BUS RUN and CfgF LED .....	98
9.1.5	LED Display LNK/ACT .....	98
9.1.6	LED Display Status .....	99
9.1.7	LED Display POWER US and UA.....	99
9.1.8	Advanced LED Display .....	100
9.2	PROFINET Diagnostics.....	101
9.2.1	Device-Related Diagnostic Messages .....	101
9.2.2	Diagnostic Messages to IO-Link Ports via IODD .....	101
9.2.3	Diagnostic Messages to IO-Link Ports.....	102
<b>10</b>	<b>Web Server.....</b>	<b>103</b>
10.1	Start Web Server.....	103
10.2	Access and Login.....	103
10.3	Start Screen .....	105
10.4	Menu Bar.....	105
10.4.1	STATUS Menu.....	106
10.4.2	PARAMETERS Menu .....	108
10.4.3	DIAGNOSTICS .....	109
10.4.4	IODD CATALOG Menu.....	110
10.4.5	MAINTENANCE Menu .....	110
10.5	IO-Link Master Port.....	111
10.5.1	STATUS Menu.....	111
10.5.2	INFORMATION Menu .....	112
10.5.3	CONFIGURATION Menu.....	113
10.5.4	IO-LINK PARAMETERS Menu .....	114
10.5.5	PROCESS DATA Menu.....	115
10.6	Digital IO Channels / IO Overview .....	115
10.6.1	Input Data .....	115
10.6.2	Output Data.....	116
10.7	Settings / Maintenance.....	116
10.7.1	DEVICE CONFIGURATION Menu .....	116
10.7.2	MAINTENANCE INFORMATION Menu.....	117
10.7.3	FIRMWARE Menu .....	118
10.7.4	FACTORY RESET Menu .....	118
10.8	User Management.....	118
<b>11</b>	<b>Maintenance Instructions .....</b>	<b>120</b>

<b>12 Proper Disposal .....</b>	<b>121</b>
<b>13 Declarations of Conformity.....</b>	<b>122</b>

# 1 General

## 1.1 Information Concerning these Instructions

- These instructions make it possible to use the product safely and efficiently.
- These instructions are an integral part of the product and must be kept on hand for the entire duration of its service life.
- Local accident prevention regulations and national work safety regulations must be complied with as well.
- The product is subject to further technical development, and thus the information contained in these operating instructions may also be subject to change. The current version can be found at [www.wenglor.com](http://www.wenglor.com) in the product's separate download area.



### INFORMATION

The operating instructions must be read carefully before using the product and must be kept on hand for later reference.

## 1.2 Explanation of Symbols

- Safety precautions and warnings are emphasized by means of symbols and signal words.
- Safe use of the product is only possible if these safety precautions and warnings are adhered to.

The safety precautions and warnings are laid out in accordance with the following principle:

### SIGNAL WORD

#### Type and source of danger!

Possible consequences in the event that the hazard is disregarded.

→ Measures for averting the hazard.

The meanings of the signal words, as well as the scope of the associated hazards, are listed below:



### DANGER

This signal word indicates a hazard with a high degree of risk which, if not avoided, results in death or severe injury.



### WARNING

This signal word indicates a hazard with a medium degree of risk which, if not avoided, may result in death or severe injury.



### CAUTION

This signal word indicates a hazard with a low degree of risk which, if not avoided, may result in minor or moderate injury.



### NOTICE

This signal word draws attention to a potentially hazardous situation which, if not avoided, may result in property damage.



## INFORMATION

Information draws attention to useful tips and suggestions, as well as information on efficient, error-free use.

---

### 1.3 Limitation of Liability

- The product has been developed in consideration of the current state-of-the-art technology, as well as applicable standards and guidelines. Subject to change without notice.
- A valid declaration of conformity can be accessed at [www.wenglor.com](http://www.wenglor.com) in the product's separate download area.
- wenglor sensoric elektronische Geräte GmbH (hereinafter referred to as "wenglor") excludes all liability in the event of:
  - Non-compliance with the instructions
  - Use of the product for purposes other than those intended.
  - Use by untrained personnel.
  - Use of unapproved spare parts.
  - Unapproved modification of products.
- These operating instructions do not include any guarantees from wenglor with regard to the described procedures or specific product characteristics.
- wenglor assumes no liability for printing errors or other inaccuracies contained in these operating instructions unless wenglor was verifiably aware of such errors at the point in time at which the operating instructions were prepared.

### 1.4 Copyrights

- The contents of these instructions are protected by copyright law.
- All rights are reserved by wenglor.
- Commercial reproduction or any other commercial use of the provided content and information, in particular graphics and images, is not permitted without previous written consent from wenglor.

## 2 For Your Safety

### 2.1 General Safety Instructions



#### **DANGER**

##### **High electrical voltage in the machine/system.**

Death or serious injury from electric shock.

→ Comply with the five safety rules of electrical engineering when working on the machine/equipment.

##### **Protection of Persons and Property**

According to DIN VDE 0105-100 – Operation of electrical systems – Part 100: General specifications

##### **The Five Safety Rules**

Protect against high voltage

1. Enable.
2. Secure against being switched on again.
3. Check that there is no voltage at all poles.
4. Ground and short-circuit.
5. Cover or cordon off adjacent live parts.

##### **Specialist Personnel**

Only qualified and safety-technically instructed personnel may install, commission and operate the device.

You are qualified if you meet the following conditions:

- You have suitable electrical training.
- You have been instructed by the machine operator in the operation of the system and the applicable safety regulations.
- You have access to the operating instructions and the manual.
- You are familiar with the safety standards of automation technology.
- You are familiar with the basic and technical standards applicable to the specific application.

##### **Use of the Device**

Observe all safety and accident prevention regulations during project planning, installation, initial startup, operation and testing of the device.

When using aggressive media, check the material resistance.



#### **INFORMATION**

Only qualified personnel from wenglor Sensoric GmbH may perform interventions in the hardware and software, with the exception of firmware updates.



#### **INFORMATION**

Only use a power supply unit that allows max. 60 V DC or 25 V AC in the event of a fault. It must comply with SELV or PELV.

## Safety Measures of the Machine Operator

- Follow the instructions in this manual.
- Observe the test specifications in the operating instructions of all connected components.

## 2.2 Use for Intended Purpose

The EP8 family of devices are decentralized devices. They can be used in harsh industrial environments up to IP67 degree of protection.

The intended operation of the devices and the degree of protection IP67 is only guaranteed if open plugs and sockets are closed with locking screws.

Intended use also includes EMC-compliant electrical installation. The device is intended for use in industrial environments. When used in residential or mixed-use areas, radio interference may occur.

When using the device in residential or mixed-use areas, observe the applicable standards.

### Foreseeable Misuse

- Do not modify the device structurally, technically or electrically.
- Do not use the device outside the areas described in this manual, the technical data and the operating instructions.
- Do not use the device as a safety-related device. It does not comply with the relevant standards. Safety functions of the system are not guaranteed!
- Switching the device outputs to the off state may not be used for safety requirements for the respective machine or system!
- Do not use the device outdoors or for permanent operation in liquids.
- Do not clean the device with a high-pressure cleaner.
- Do not use the device as a climbing aid.

Warranty and liability claims are forfeited if:

- the device is not used as intended,
- damage is due to failure to observe the manual and operating instructions,
- the personnel was/is not competent.

## 3 Description

### 3.1 Device

#### EP08P001

- PROFINET, compact module, plastic
- PROFINET via M12 D-coded
- Power via M12 Power L-coded, 5-pin
- 8 x M12 slots, digital inputs/outputs/8 IOL

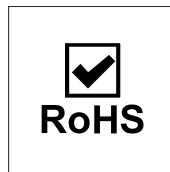
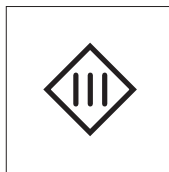

### 3.1.1 Device Configuration

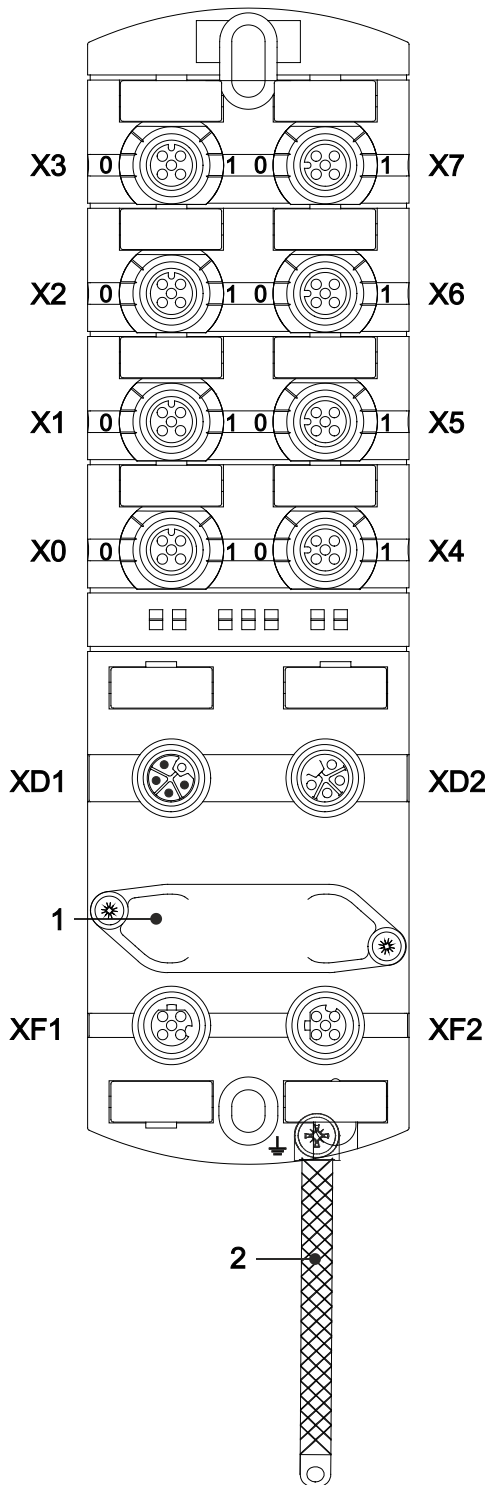

X0 ... X7 Digital inputs and outputs or IO-Link M12 A-coded

0 Channel corresponds to Pin 4

1 Channel corresponds to Pin 2

Examples:

Channel 02 = Pin 4 Socket X2

Channel 16 = Pin 2 Socket X6

XD1 Voltage supply POWER IN, M12 L-coded, 5-pin

XD2 Voltage supply POWER OUT, M12 L-coded 5-pin

1 Rotary switch

XF1 Ethernet port 1, M12 D-coded

XF2 Ethernet port 2, M12 D-coded

2 Ground strap for functional earth

## 3.1.2 Pin Assignments

### M12 Socket, A-Coded

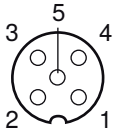
X0...X7		
	Pin 1	24 V DC
	Pin 2	DI/DO
	Pin 3	0 V
	Pin 4	DI/DO/IO-Link
	Pin 5	0 V

### M12 Plug/Socket, L-Coded

#### POWER IN/OUT

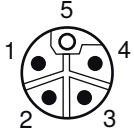
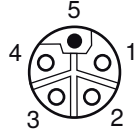
XD1		XD2	
	Pin 1	24 V DC	
	Pin 2	0 V	
	Pin 3	0 V	
	Pin 4	24 V DC	
	Pin 5	±	

### M12 Socket, D-Coded

#### Port 1 / Port 2

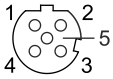
XF1 / XF2		
	Pin 1	TD +
	Pin 2	RD +
	Pin 3	TD -
	Pin 4	RD -
	Pin 5	Unused

### 3.1.3 Display Units

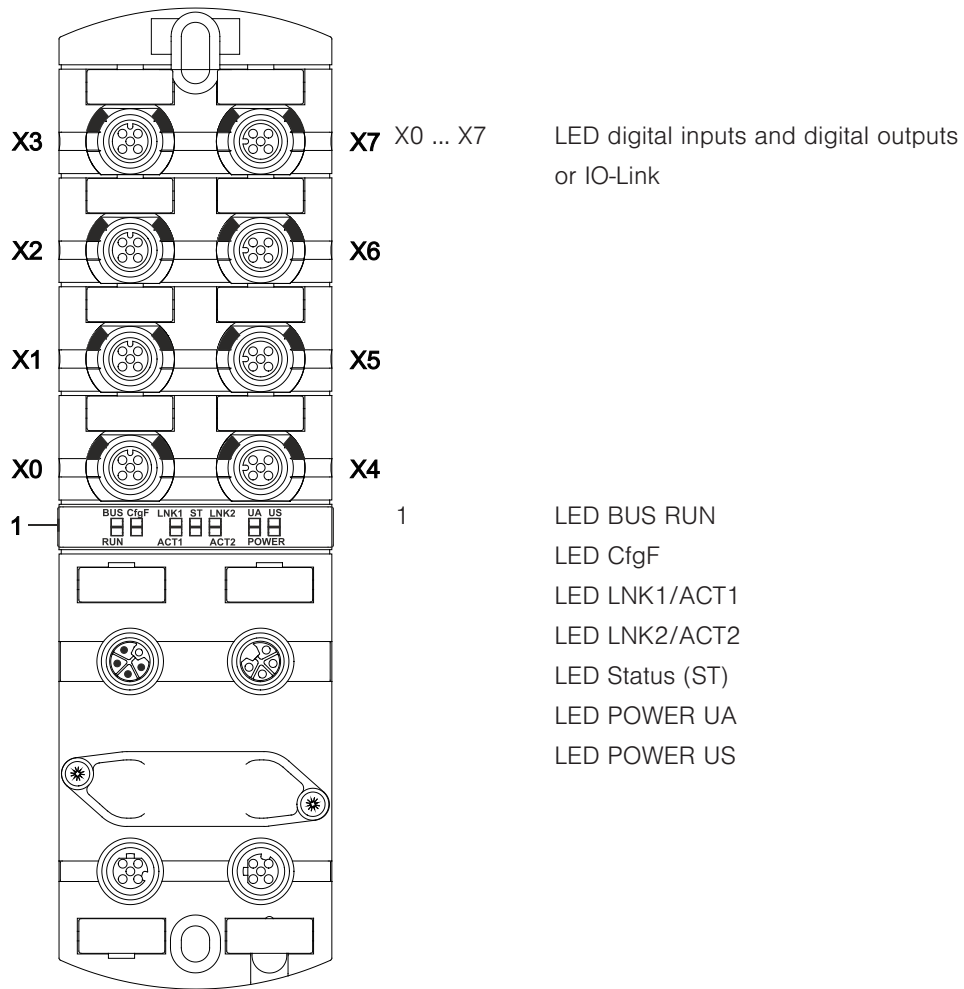

#### INFORMATION

For more information on the behavior of the LEDs, see Section LED Display [► 95] 9.1

## 4 Technical Data

### 4.1 Electrical data

Bus Data		
Bus protocol		PROFINET
Connection		M12, 4-pin, D-coded
PROFINET Conformance Class		C
Transmission speed 100 Mbit/s		100 Mbit/s
PROFINET addressing		Via DCP
Cycle time		≥1 ms
IRT	Network communication	Yes
	Application	No
MRP	Client	Yes
SNMP		Yes
PROFINET Netload Class		III

OPC UA Server		
OPC UA Server	According to "IO-Link Companion Specification"	Yes
Transport		UA TCP, UA Secure Conversation, UA Binary Encoding
Server profile		Micro embedded device
Protocol		OPC UA TCP
User access	Read access only	Anonymous
	Read and write access	Username/password
Number of sessions		2
Number of subscriptions per session		2
Number of "Monitored Items" per session		20
Minimum publication interval		100 ms
Maximum number of sessions/clients		5
Data coding		UA binary
Energy monitoring	Current and voltage	Yes
Temperature monitoring		Yes

MQTT client		
MQTT		Client
Client services		Publish
Protocols	Via TCP	MQTT
Topic size	Individually per MQTT publication and	≤ 256 bytes
		≤ 256 bytes

MQTT client		
	Common topic prefix of the associated MQTT connection	
Topics		- Printable UTF-8 string - ZERO-terminated - Multi-byte encoding (MBCS) - Payload: JSON
Will Topic		≤ 256 bytes
Quality of service		QoS 0, QoS 1 and QoS 2
IP standard		IPv4
Port	1883 (standard)	MQTT unencrypted
MQTT standard		V3.1.1
JSON, MQTT	JSON integration for IO-Link V1.0.0	Yes, via REST API and MQTT
Energy monitoring	Current and voltage	Yes
Temperature monitoring		Yes
Restriction		The service "Subscribe" not supported

Web server		
HTTP		HTTP/1.1
Port		80
Connections	Via TCP	≤8 simultaneous connections. A connection is being edited.
JavaScript		Required
HTTPS		Not supported

REST API		
Standard	According to "JSON Integration for IO-Link, Version 1.0.0, Mar 2020" <a href="https://io-link.com/share/Downloads/IO-Link_Integration/JSON_Integration_10222_V100_-Mar20.zip">https://io-link.com/share/Downloads/IO-Link_Integration/JSON_Integration_10222_V100_-Mar20.zip</a>	Yes
Protocol		HTTP
User access	Read access only Read and write access	Anonymous Username/password
Authentication	According to RFC 7617	HTTP Basic Authentication
Supported endpoints		Refer to product manual

IO-Link		
Operating voltage IO-Link devices		24 V DC
Voltage range IO-Link devices		20...30V DC
Transmission speed		COM1 / COM2 / COM3
Standardized Master Interface (SMI)		See IO-Link specification

IO-Link		
Transmission speed detection		Automatic

Supply Power		
Operating voltage US		24 V DC
Voltage range US		18...30 V DC
	When using IO-Link	20.3...30 V DC
Operating voltage UA		24 V DC
Voltage range UA		18...30 V DC
Sensor current US	$\leq 40\text{ }^{\circ}\text{C}$ (see derating)	$\leq 16\text{ A}$
Actuator current UA	$\leq 40\text{ }^{\circ}\text{C}$ (see derating)	$\leq 16\text{ A}$
Current consumption	In idle	$\leq 0.18\text{ A}$
Reverse polarity protection for US and UA		Yes
Reverse polarity protected		Yes
Connection		M12, 5-pin, L-coded
Cable cross section	Current per supply $\leq 12\text{ A}$	$\geq 1.5\text{ mm}^2$
	Current per supply $> 12\text{ A}$	$\geq 2.5\text{ mm}^2$

Input (DI)		
Sensor power supply	Per port, $\leq 40\text{ }^{\circ}\text{C}$ (see derating)	$\leq 2\text{ A}$ load Automatic start
Total current sensor supplies	$\leq 40\text{ }^{\circ}\text{C}$ (see derating)	$\leq 10\text{ A}$
Filter time		0 ... 15 ms + $t_{\text{cycle}}$ , configurable
Delay time at signal change		2 ... 5 ms
Input characteristics	EN 61131-2	Type 1 + Type 3
Short-circuit protection sensor supply		MOSFET with current measurement
Connection		M12, 5-pin, A coded
Cable cross-section M12		$\leq 0.75\text{ mm}^2$
Cable Length		$\leq 30\text{ m}$
Total current	Per port	$\leq 4\text{ A}$

Output (DO)		
Output current DO (UA)	Per pin, $\leq 40\text{ }^{\circ}\text{C}$ (see derating)	$\leq 2\text{ A}$
Total current outputs	$\leq 40\text{ }^{\circ}\text{C}$ (see derating)	$\leq 10\text{ A}$
Switching frequency		$\leq 50\text{ Hz}$
Actuator short-circuit protection		MOSFET with current measurement
Connection		M12, 5-pin, A coded
Cable cross-section M12		$\leq 0.75\text{ mm}^2$
Cable Length		$\leq 30\text{ m}$
Total current	Per port	$\leq 4\text{ A}$

## Derating

### Sensor Current US/Actuator Current UA

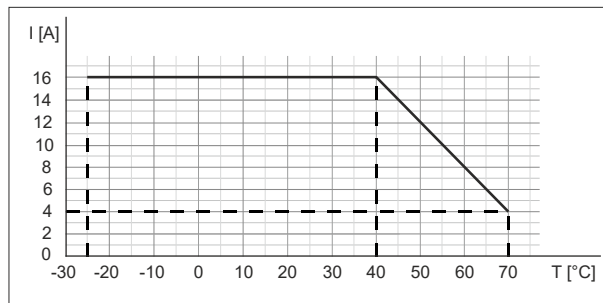

### Derating Total Current Sensor Supplies/Total Current Outputs

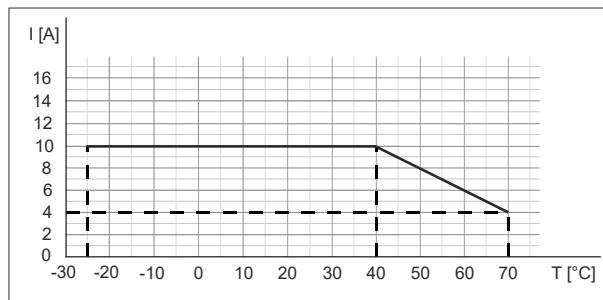

### Derating Current per Sensor Supply/Output

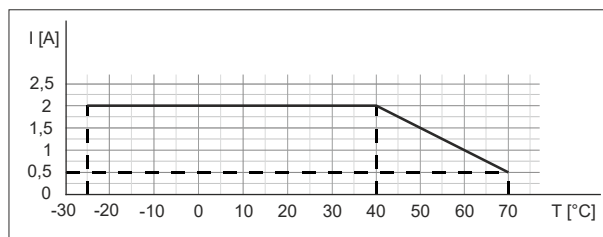

## 4.2 Ambient Conditions

Climatic Conditions		
Ambient temperature		-40 °C ... +70 °C
Storage temperature	Provide for acclimatization for initial start-up	-40 °C ... +85 °C
Transport temperature	Provide for acclimatization for initial start-up	-40 °C ... +85 °C
Relative humidity		≤ 95%
Installation altitude	Above normal height	≤ 3,000 m

Mechanical Characteristics		
Vibration testing	EN 60068 Part 2–6	10 ... 58 Hz, oscillation range 0.35 mm, 58 ... 150 Hz; 20 g
Shock test	EN 60068 Part 2–27	50 g, duration 11 ms

Electric Safety		
Degree of protection	EN 60529	IP67
Protection class	Using a SELV or PELV power supply	III
Pollution degree		2

EMC Interference Emission		
Radio interference field strength housing	EN 55016-2-3	Compliant

EMC Interference Immunity		
Electrostatic discharge (ESD)	EN 61000-4-2	Compliant
High frequency electrical fields	EN 61000-4-3	Compliant
Fast transients burst	EN 61000-4-4	Compliant
Surge voltages	EN 61000-4-5	Compliant
Conducted HF	EN 61000-4-6	Compliant
Voltage dips	EN 61000-4-11	Compliant

## 4.3 Protection

Equipment Protection		
Overvoltage protection		Yes
Overload protection device supply	To be ensured by load circuit monitoring	Yes
Reverse polarity protection device supply		Yes
Short-circuit protection sensor supply		Electronic
Short-circuit protection output		Electronic
Protective circuit input	Internal	Suppressor diode

## 4.4 Mechanical Data

Material Data		
Housing material		Plastic

Mounting Data		
Weight	Net	470 g
Dimensions	L × W × H	225.4 × 63 × 36 mm

## 4.5 Conformity, Approvals

Conformity, Approvals		
Product standard	EN 61131-2 Programmable logic controllers part 2	Compliant
CE	2014/30/EU 2011/65/EU	Compliant
UKCA		Compliant

Conformity, Approvals		
EMC	2014/30/EU	Compliant
REACH	No. 1907/2006	E201820
WEEE	2012/19/EU	Compliant
UL		E201820
RoHS	2011/65/EU & 2015/863	Exception 6c&7a
China RoHS	SJ/T 11364-2014	25 EPUP

Hazardous substance (有害物質)							
	Part Name	Lead	Mercury	Cadmium	Hexavalent	Polybrominated	Polybrominated
	零件名稱	(Pb) 鉛	(Hg) 汞	(Cd) 鎘	Chromium (Cr (VI)) 六价铬	biphenyls (PBB) 多溴联苯	diphenyl ethers (PBDE) 多溴联苯醚
	Component part PCB <sup>1 2</sup> 組件部分 印刷电路板	X	0	0	0	0	0
	Connection Terminal / Screws / Housing <sup>3</sup> 接线端子 / 拧 / 外壳	X	0	0	0	0	0
<p>O : Indicates that the content of the harmful substance in all homogeneous materials of the component part is below the limit defined in GB/T 26572. O : 表明該有害物質在組成部分的所有均質材料的含量低於按GB/ T26572定義的限制。</p> <p>X: Indicates that the content of the harmful substance in at least one homogeneous material of the component part exceeds the limit defined in GB/T 26572. X: 表示該有害物質在組成部分中的至少一個均質材料的含量超過按GB / T26572定義的限制。</p>							

## 4.6 Used IP Ports

Port	
UDP port 161	SNMP server
UDP port 34964	PROFINet RPC endpoint mapper
UDP port 49152	PROFINet RPC device server
TCP port 80	Integrated web server
TCP port 4840	Integrated OPC UA server. Default value. Port number can be modified by configuration.
UDP 55510	AutoUpdateX V3 Protocol



### INFORMATION

There is no fixed or configurable port for the MQTT client. If MQTT client is activated, it is assigned to the next free port of the IP stack.

## 5 Installation

### 5.1 Prerequisites

Prerequisites for installation:

- Flat mounting surface for mechanically stress-free mounting.
- Provide suitable grounding.
- Suitable installation location with regard to vibration and shock load, temperature and humidity (see section 4 "Technical Data").
- Protected to prevent the connection cables from being torn off by personnel or equipment.

### 5.2 Dimensions

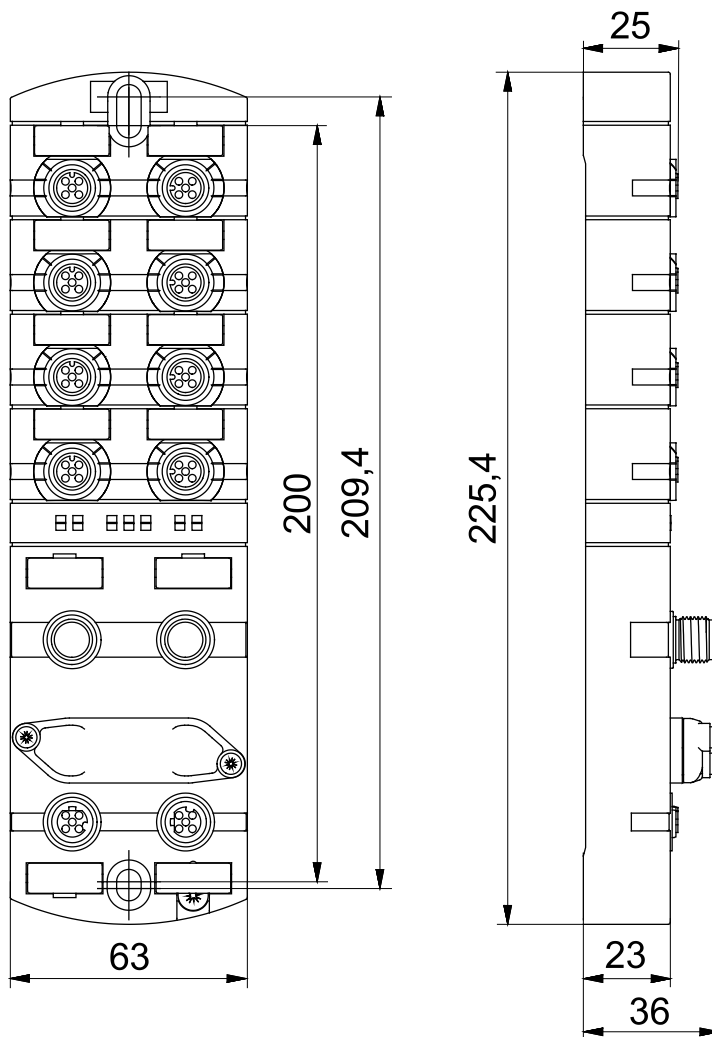

Dimensions in mm (1 mm = 0,03937 Inch)

## 5.3 Mounting Clearance

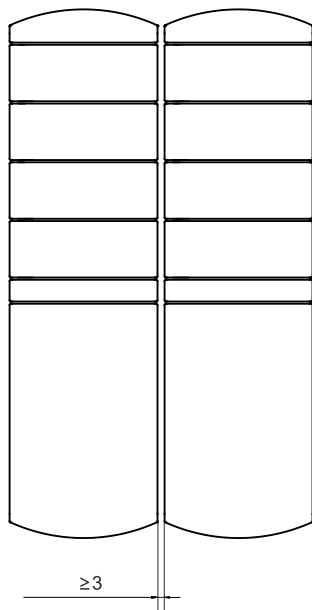

Distance in mm



### INFORMATION

For proper installation and improved heat dissipation, we recommend maintaining a minimum distance of 3 mm when mounting the IO-Link Master.



### INFORMATION

A minimum distance of 50 mm must be maintained when using angled plugs.

## 5.4 Installation of the Unit



### NOTICE

#### Material damage due to incorrect installation.

The mounting screws and tightening torques depend on the subsurface of the installation site.

1. Use mounting screws according to the condition of the mounting surface.
2. Tighten the screws carefully. The specified tightening torques must be observed.



### NOTICE

#### Material damage due to misuse.

Do not use the equipment as a climbing aid. Misuse may cause the devices to tear off or otherwise be damaged.

- Mount the devices in such a way that they cannot be used as climbing aids.

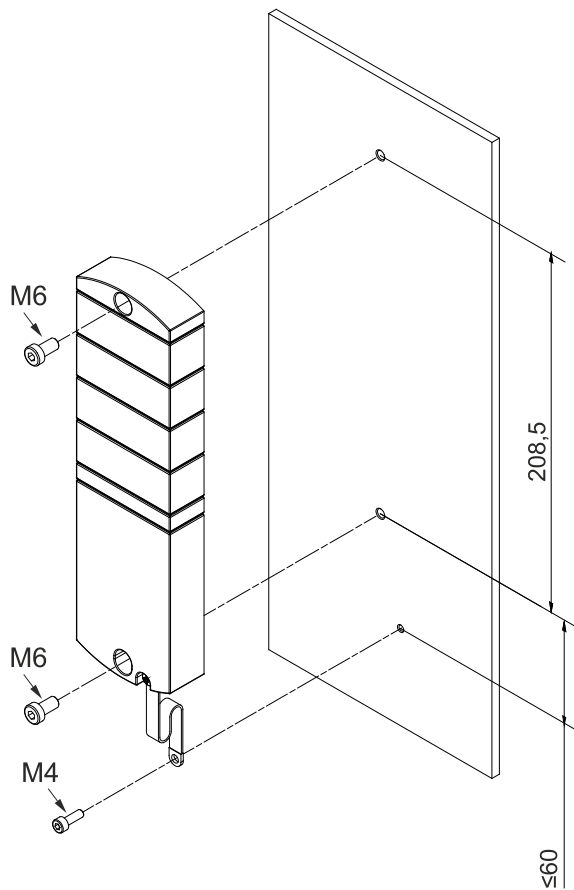

Secure the device. Dimensions in mm (similar to figure)

M6: 3 Nm torque

M4: 1.2 Nm torque

Mount the device in the specified order:

1. Slightly tighten the second M4 screw.
2. Align the housing.
3. Slightly tighten the bottom M4 screw.
4. Tighten the M4 screws according to the torque.
5. Ground the device: Fasten ground strap (Functional Earth ► 22)].



## INFORMATION

The mounting screws and nuts are not included in the scope of delivery.

## 5.5 Functional Earth



### INFORMATION

#### Note

Fasten the ground strap with a conductive screw.

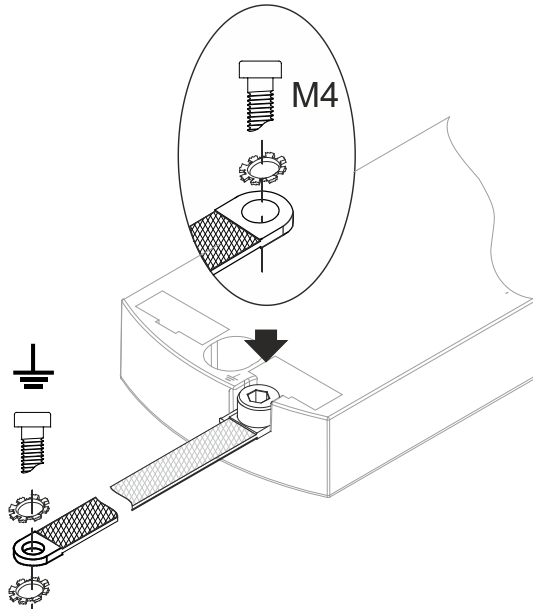

M4 tightening torque 1.2 Nm

## 5.6 Addressing Cover

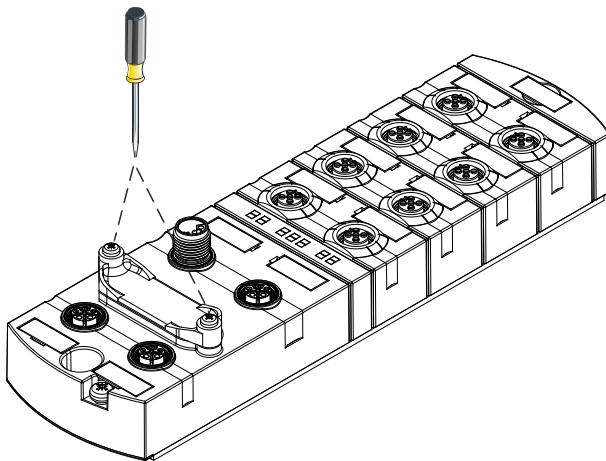

Attaching the addressing cover

M3 tightening torque 0.8 Nm



### INFORMATION

Information on setting the rotary switches can be found in section [Adjusting the Rotary Switch](#) [► 24]

## 6 Installation

### 6.1 Installing the Unit Electrically



#### **DANGER**

##### **High electrical voltage in the machine/system.**

Death or serious injury from electric shock.

→ Comply with the five safety rules of electrical engineering when working on the machine/equipment.

#### **Protection of Persons and Property**



#### **WARNING**

##### **Risk of fire due to short circuit.**

Supply lines and/or devices damaged by a short circuit can overheat and cause fires!

→ Provide intelligent current monitoring or fuse. The fuse must be rated for max. 9 A.



#### **CAUTION**

##### **Loss of function due to improper installation.**

Failure to observe this may result in damage to property and personal injury.

→ Only install cables and accessories that comply with applicable safety and electromagnetic compatibility requirements and regulations, and if applicable correspond with any telecommunication terminal devices and their specifications.



#### **CAUTION**

##### **Hot interface.**

Slight bodily injury due to contact with the surface and damage to the equipment.

1. Wear suitable heat-resistant gloves.
2. Only use thermally suitable connection cables.



#### **NOTICE**

##### **Damage to the machine/system due to improper switching on of the voltage sources.**

When switching on the device with separate actuator and sensor, the function of the digital inputs and outputs is not guaranteed.

→ Always switch on the voltage sources in this order:

1. Switch on sensor voltage.
2. Switch on the actuator voltage.



## INFORMATION

Only use a power supply unit that allows max. 60 V DC or 25 V AC in the event of a fault. It must comply with SELV or PELV.

### 6.1.1 Adjusting the Rotary Switch



## INFORMATION

**Default settings:** The rotary switches are set to **000**.



## INFORMATION

Each participant must have a clear and unique IP address in the network.

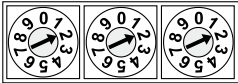
x 100   x 10   x 1 	<b>Address range 1 ... 999</b> x1 rotary switch (one) x10 rotary switch (tens) x100 rotary switch (hundreds)
---	---

Position/ Range	Web server	JSON	OPC UA	MQTT	Description	
0	_**	_**	_**	_**	Normal operation	
001 ... 910	_**	_**	_**	_**	Reserved**	
911	Deacti- vated	Deactivated	Deactivated	Deacti- vated	Secure mode	Fieldbus communica- tion in normal opera- tion
912	_**	Deactivated	Deactivated	Deacti- vated	IloT mode deactivated	
913	Deacti- vated	Deactivated			Web server and JSON deactivated	
914	Activated	Activated	Activated	Activated	Activates all IloT protocols and the web server.	
915-978	_**	_**	_**	_**	Reserved*	
979	Activated	Activated	Deactivated	Deacti- vated	Default settings reset	Procedure only for this rotary switch position: 1   Disconnect the unit from the voltage supply. 2   Set switch position 979. 3   Connect the power supply. 4   Wait until reset is complete.

Position/ Range	Web server	JSON	OPC UA	MQTT	Description
					<ul style="list-style-type: none"> <li>• ST LED flashes green: Device carries out reset.</li> <li>• ST LED lights up green: Reset is complete.</li> </ul> ST LED display, see 9.1 “LED display” 5   Disconnect the power supply. 6   Switch position to 000 or another desired position. 7   Connect the power supply.
980-999	_*	_*	_*	_*	Reserved*



## INFORMATION

### \* Note

Reserved switch positions have no fieldbus communication, see LED Display [► 95]



## INFORMATION

### \*\* Note

The last protocol setting is retained.

## Service Setting

The switch positions 911, 912 and 913 switch off the services of the device marked in the “Set Address” matrix. In these switch positions, the device starts normally with the previously set address configuration and has no function restrictions, except for the services deactivated by the switch position. The services deactivated as a result could not be activated again by other means, e.g. the configuration data of the control system.

Switch position 914 reactivates all services. Here too, the function of the device is not restricted.

1. Connect the power supply.
2. Disconnect the power supply.
3. Set original address.

## Setting the Address

1. Disconnect the device power supply.
2. Remove the addressing cover.
3. Set a unique address.
4. Mount the addressing cover.
5. Connect the power supply.

The tightening torques can be found in section Addressing Cover [► 22]

## 6.1.2 Sensors and Actuators

### Connect the M12 Socket

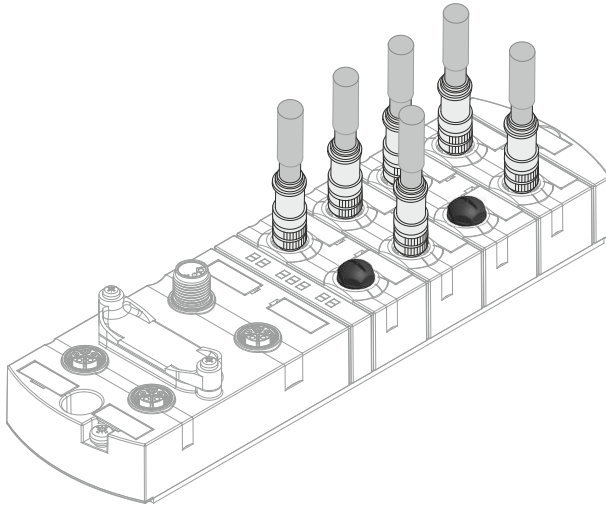
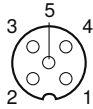

Example connection M12 inputs and outputs

Tightening torque 0.6 Nm

The pin assignment of the slots can be found in section “Pin Assignments [► 11]”



### INFORMATION

Feeding in an external ground via the M12 sockets can lead to errors.

→ Do not feed any external ground into the device via the M12 sockets.



### INFORMATION

The cable length of the sensor and actuator cables is limited to 30 m.

### Sensor Power Supply

- Sensors can be supplied with power via **pin 1** (24 V) and **pin 3** (0 V) at the M12 sockets.
- The maximum permissible current for supplying the sensors is **2 A** per M12 socket.
- In the event of an overcurrent or short circuit, the connected wire or sensor must **be removed** from the M12 socket.

### Status of IO-Link Communication

The device supports IO-Link communication at the following speeds:

- 4,800 baud (COM 1)
- 38,400 baud (COM 2)
- 230,400 baud (COM 3)



## INFORMATION

The device automatically selects the correct transmission speed for the IO-Link device.



## INFORMATION

The cable length for IO-Link connection is limited to max. 20 m.

### 6.1.3 PROFINET IO Communication

#### Connect the M12 Socket

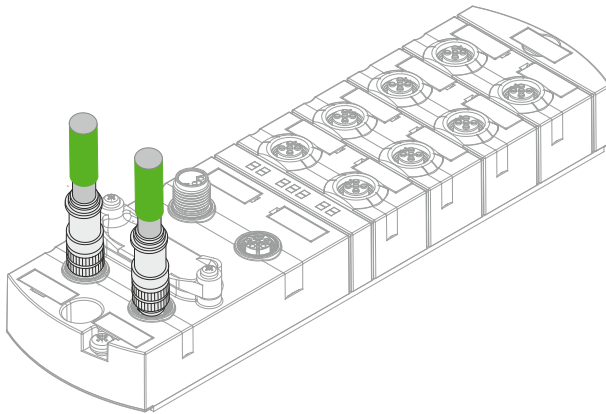
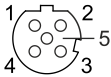

Example connection M12 BUS

Tightening torque 0.6 Nm

The pin assignment of the slots can be found in section “Pin Assignments [▶ 11]”

### 6.1.4 Power Supply

#### Connect the M12 Plug POWER IN

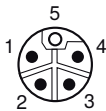

#### Connect M12 Socket POWER OUT

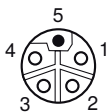

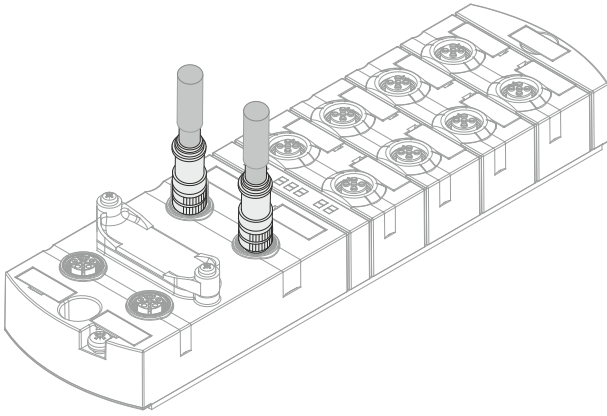

Example connection M12 POWER

Tightening torque 0.6 Nm

The pin assignment of the slots can be found in section “Pin Assignments [► 11]”

## 6.2 Ensure Tightness (IP67)



### ⚠ CAUTION

#### Leaky housing

Personal injury and material damage due to the ingress of conductive liquids in the event of device failure.

→ Seal unused plugs and sockets.

#### Connection Lines

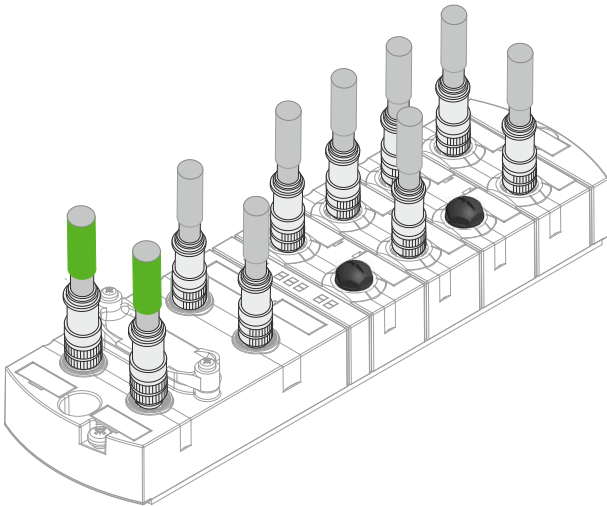

Connection lines

Tightening torque 0.6 Nm

## 7 Initial Start-Up



### **WARNING**

#### **Danger of burns!**

It is forbidden to loosen or make electrical connections during operation. Failure to observe this rule results in a risk of arcing, which can cause burns.

→ Switch off the power supply to the unit



### **CAUTION**

#### **Uncontrolled processes**

Property damage and personal injury due to incorrectly performed initial start-up phases (e.g. initial commissioning, re-commissioning and in the event of changes to the configuration).

→ Always perform initial start-up in this order:

1. Switch on the device.
2. Inspection and approval of the system by an expert.
3. Start up.



### **CAUTION**

#### **Malfunctions in the residential area**

Equipment of EMC class A may cause interference in residential areas.

→ The operator must take appropriate measures

## 7.1 Reading In the GSDML Files

### **GSDML Files**

Install the GSDML file or device description file

Refer to your engineering software manual for the procedure to import GSDML files. This operation is referred to in the engineering software as “Install GSDML files” or “Install device description file”.



### **INFORMATION**

The GSDML file is stored on the website of wenglor sensoric GmbH under the article number of the device in the download area under Product description file

### **Hardware Catalog**

Read the GSDML file of the EP8P001 into the hardware catalog of the hardware configuration program.

When using TIA, the module can then be found in the hardware catalog in the directory structure:

**Additional field devices | PROFINET IO | I/O | wenglor sensoric | EP8P001 | V1.0**

If the engineering software supports structuring in folders, then the module is displayed similar to the figure “Hardware catalog”.

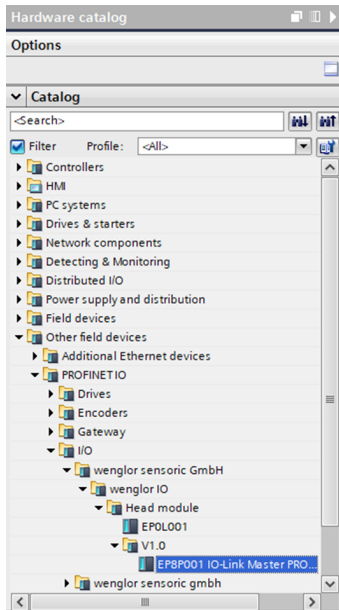

1. Mark the EP8P001 module in the hardware catalog.
2. Drag and drop the entry to a free position in “Devices & networks”.

## Assign Module to a New IO Controller

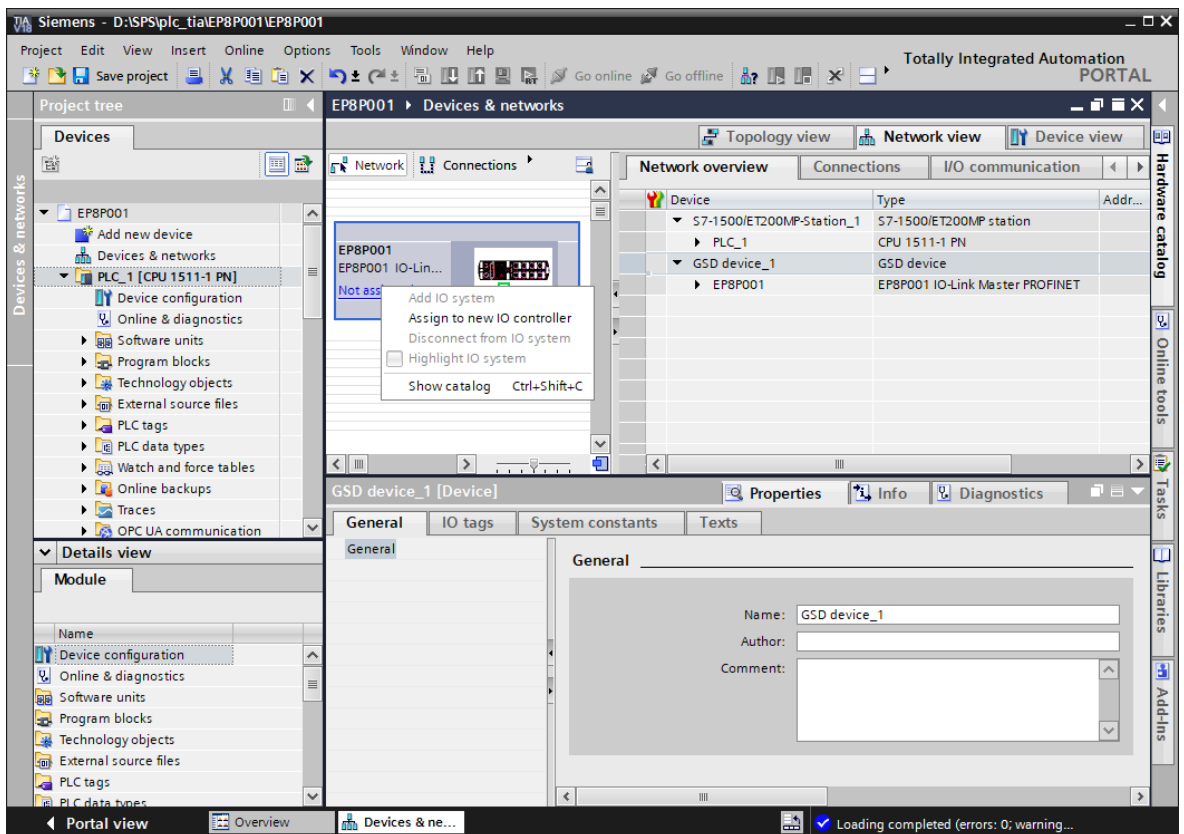

- Click Not assigned on the module icon.
- Select PLC\_1.PROFINET-interface\_1. The module is assigned to an IO controller.
- For further configuration, select the module by double-clicking.

# 8 Configuration/Setting

## Overview

There are two options for configuring the devices.

- On the one hand, a GSDML file is available for download on the wenglor sensoric homepage. These can be imported into the programming software, as described in section “Reading In the GSDML Files [► 29]”, in order to use the advantages of the preconfigured connections.
- On the other hand, it is possible to configure the devices via the integrated web server.



## INFORMATION

To transfer index changes via the web server and acyclic ISDU writes to the data storage, a ParamDownloadStore command must be sent after the index changes.

→ The ParamDownloadStore command can be triggered by writing value 0x05 to index 0x02.

## 8.1 Changing the Configuration



### WARNING

#### Impairment of the protection function by changing the configuration of the devices

Only an authorized person may make changes to the configuration.

For configuration changes, use the password hierarchy provided by your engineering software.

The effectiveness of the safety device must be retested each time its configuration is changed.

## 8.2 Configuration Module

The individual IO-Link ports and the virtual modules can be inserted and configured via the hardware catalog.

Standard Module	
EP0P001 Device	<ul style="list-style-type: none"><li>• Parameterization of the module</li><li>• Read and write access to the digital IOs</li><li>• Read and write access to the IO-Link devices/ports</li></ul>
EP0P001 Options	<ul style="list-style-type: none"><li>• Access to system status and qualifier</li><li>• Parameterization of communication protocols</li><li>• Access for output forcing, web server and diagnostic buffer</li></ul>

### 8.2.1 Slots

The 8 hardware ports are configured and parameterized via slots 1.X0 to 1.X7. Further port-specific parameter settings can be found in the “SIO data/Module parameters” module on slot 1.1.

In the TIA Portal device view, the module has the following display:

- **Slot 1:** PROFINET device
  - with a preconfigured “SIO data/Module parameter” slot for universal IO channels and parameter settings
  - with 8 IO-Link ports
- **Slot 2:** Options module\*
  - with 8 possible submodules for project planning and parameterization
    - a) optional communication protocols

- b) the qualifier
- c) the system status
- d) the output forcings
- e) of the web server
- f) of the diagnostic buffer

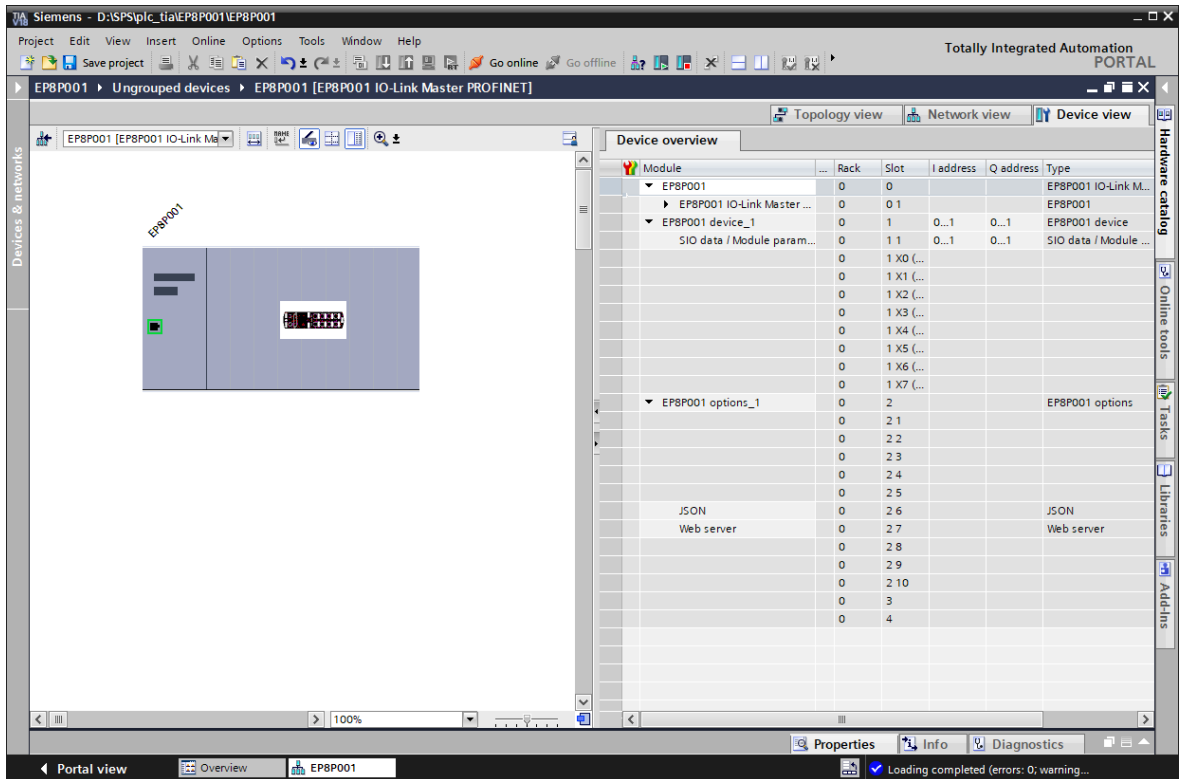

The stored slots can optionally be occupied by certain virtual submodules.

Virtual modules are used to map the various diagnostic and status information into the process map of the IO-Link master.

The assignment of the submodules to the slots is predefined via a GSDML file.

In the case of a new project, the submodules “JSON” and “Web server” are already inserted. However, they can be removed again if necessary.



## INFORMATION

\* At least one option module must be configured.

### 8.2.2 Module EP8P001 Device

#### Submodule

The module is firmly anchored in slot 1.

Name	Slot	Meaning
SIO data/ Module parameters	1.1	<ul style="list-style-type: none"> <li>• Parametrization of the module</li> <li>• Parametrization of the port</li> <li>• 2 Byte In Digital input data of the ports</li> <li>• 2 Byte Out Digital output data of the ports</li> </ul>
IO-Link port X0	1.X0 (IO-Link master port 1)	IO-Link slot.
IO-Link port X1	1.X0 (IO-Link master port 2)	Select the submodule from the hardware catalog.
IO-Link port X2	1.X0 (IO-Link master port 3)	

Name	Slot	Meaning
IO-Link port X3	1.X0 (IO-Link master port 4)	
IO-Link port X4	1.X0 (IO-Link master port 5)	
IO-Link port X5	1.X0 (IO-Link master port 6)	
IO-Link port X6	1.X0 (IO-Link master port 7)	
IO-Link port X7	1.X0 (IO-Link master port 8)	

### 8.2.2.1 IO-Link port

The module has 8 IO-Link ports on slots 1 (X0 to X7), which can be assigned specific IO-Link devices or set to SIO mode.

Read and write access to the IO-Link devices/ports.



## INFORMATION

If no suitable submodule type is available, the next largest data length must be selected.

### Submodules

Deactivated	<p><b>1 byte In</b></p> <ul style="list-style-type: none"> <li>The corresponding IO-Link port is deactivated, i.e. the channel will neither be used as a digital input or output nor as an IO-Link port.</li> <li>The input byte is reserved.</li> </ul>
Standard digital input	<p><b>0 byte in, 0 byte out</b></p> <ul style="list-style-type: none"> <li>IO-Link Standard IO mode</li> <li>The data is available at slot 1.1 "SIO data".</li> <li>The output is addressed via slot 1.1 "SIO Data/Module parameters".</li> </ul>
Standard digital output	<p><b>0 byte in, 0 byte out</b></p> <ul style="list-style-type: none"> <li>IO-Link Standard IO mode</li> <li>The output is addressed via slot 1.1 "SIO data".</li> <li>The input is addressed via slot 1.1 "SIO Data/Module parameters".</li> </ul>
IO-Link In x bytes + PQI	<p><b>x byte In</b></p> <ul style="list-style-type: none"> <li>IO-Link device with PQI and x bytes of input data.</li> <li>Arrangement of the input data in this order: <ul style="list-style-type: none"> <li>PQI data (1 byte)**</li> <li>Possibly one padding byte*</li> </ul> </li> <li>Parameterization of diagnostics and IO-Link properties possible.</li> </ul>
IO-Link Out y bytes + PQI	<p><b>y Byte Out</b></p> <ul style="list-style-type: none"> <li>IO-Link device with PQI and y byte output data.</li> <li>Input data: <ul style="list-style-type: none"> <li>PQI data (1 byte)</li> <li>one padding byte*</li> </ul> </li> <li>Parameterization of diagnostics and IO-Link properties possible.</li> </ul>
IO-Link In/Out x/y byte + PQI	<p><b>x byte In, y byte Out</b></p> <ul style="list-style-type: none"> <li>IO-Link device with PQI and x byte input data and y byte output data.</li> <li>Arrangement of the input data in this order: <ul style="list-style-type: none"> <li>Current input data of the IO-Link device</li> <li>PQI data (1 byte)</li> </ul> </li> </ul>

	<ul style="list-style-type: none"> <li>- possibly one padding byte*</li> <li>• Parameterization of diagnostics and IO-Link properties possible.</li> </ul>
Profile devices (various)	<p>The number of input and output data bytes is module-specific.</p> <ul style="list-style-type: none"> <li>• Arrangement of the input data in this order: <ul style="list-style-type: none"> <li>- Current input data of the IO-Link device (if available)</li> <li>- PQI data (1 byte)</li> <li>- possibly one padding byte*</li> </ul> </li> <li>• Arrangement of the output data in this order: <ul style="list-style-type: none"> <li>- Current output data of the IO-Link device (if available)</li> <li>- possibly one padding byte</li> <li>- Parameterization of diagnostics and IO-Link properties possible.</li> </ul> </li> </ul>
ME devices (various)	<p>The number of input and output data bytes is module-specific.</p> <ul style="list-style-type: none"> <li>• Arrangement of the input data in this order: <ul style="list-style-type: none"> <li>- Current input data of the IO-Link device (if available)</li> <li>- PQI data (1 byte)</li> <li>- possibly one padding byte*</li> </ul> </li> <li>• Arrangement of the output data in this order: <ul style="list-style-type: none"> <li>- Current output data of the IO-Link device (if available)</li> <li>- possibly one padding byte*</li> <li>- Parameterization of diagnostics and IO-Link properties possible.</li> <li>- Parameterization of the device by module-specific parameters possible (if available).</li> </ul> </li> </ul>

\* **Padding byte:** Reserved byte to achieve an even data length.

\*\* **PQI:** The port qualifier information (PQI) provides status information about the IO-Link port or the device status.

The flags "PQ"..and DevErr and DevCom" are copied directly from the ArgBlock of the SMI service "SMI\_PDIn".

The flags in bits 2 to 4 are generated within the master application layer.

## Layout of the PQI flag bits

Bit7	Bit6	Bit5	Bit4	Bit3	Bit2	Bit1	Bit0
Validity of the device process data	Port/device error display	Device communication	Port operation	Replacement device detection	New parameter	Reserved ("0")	Reserved ("0")
PQ	DevErr	DevCom	PortActive	SubstDev	New-Par	-	-

Flag	M/O	Value	Value Description
NewPar	M	0	No update of the device parameters detected.
		1	Update of the device parameters detected: Master has performed a data memory upload and a new IOLD backup object (0xB901) is available.
SubstDev	M	0	No replacement device detected (identical serial number)
		1	Replacement device recognized (different serial number)
PortActive	M	0	Port deactivated via port function
		1	Port activated (default value)
DevCom	M	0	No device available.
		1	Device detected and is in Pre-Operate or Operate status.
DevErr	M	0	No error/warning occurred.

Flag	M/O	Value	Value Description
		1	Error/warning assigned to the device or port has occurred.
PQ	M	0	Invalid IO process data from the device.
		1	Valid IO process data from the device.

### Byte assignment of the generic IO-Link In/Out xx/yy

Byte	Submodule type															
			Input data submodule								Output data submodule					
	DEAC	SIO	00/yy	01/yy	02/yy	04/yy	08/yy	16/yy	32/yy	xx/00	xx/01	xx/02	xx/04	xx/08	xx/16	xx/32
0	R		PQI	I	I	I	I	I	I		O	O	O	O	O	O
1			R	PQI	I	I	I	I	I		R	O	O	O	O	O
2					PQI	I	I	I	I				O	O	O	O
3					R	I	I	I	I				O	O	O	O
4						PQI	I	I	I					O	O	O
5						R	I	I	I					O	O	O
6							I	I	I					O	O	O
7							I	I	I					O	O	O
8							PQI	I	I						O	O
9							R	I	I						O	O
10								I	I						O	O
11								I	I						O	O
12								I	I						O	O
13								I	I						O	O
14								I	I						O	O
15								I	I						O	O
16								PQI	I							O
17								R	I							O
18									I							O
19									I							O
20									I							O
21									I							O
22									I							O
23									I							O
24									I							O
25									I							O
26									I							O
27									I							O
28									I							O
29									I							O
30									I							O
31									I							O
32									PQI							
33									R							

Legend:

I = Input

O = Output

P = PQI (Port Qualifier Information = PQI)

R = Reserved (padding byte)

DEAC = Deactivated

SIO Mode

## 8.2.3 Module EP8P001 options

- Is firmly anchored in slot 2
- All submodules are optional
- However, at least one module must be inserted.

### Submodules

Name	Slot	Meaning
Qualifier DI	2.1	<b>2 Byte In</b> <ul style="list-style-type: none"><li>• Status of the individual bits of the inputs in "Digital IO"<ul style="list-style-type: none"><li>– 0: invalid</li><li>– 1: valid</li></ul></li><li>• Layout according to parameterization</li></ul>
Qualifier DO	2.2	<b>2 Byte In</b> <ul style="list-style-type: none"><li>• Status of the individual bits of the outputs in "Digital IO"<ul style="list-style-type: none"><li>– 0: invalid</li><li>– 1: valid</li></ul></li><li>• Layout according to parameterization</li></ul>
System status*	2.3	<b>4 Byte In</b> <ul style="list-style-type: none"><li>• Summary of the current system status.</li></ul>
MQTT	2.4	Possibility to activate MQTT
OPC UA	2.5	Possibility to activate OPC UA
JSON	2.6	Possibility to activate JSON
Web server	2.7	Possibility to activate web servers
Output forcing	2.8	Possibility to activate output forcings
Diagnostic buffer	2.9	Possibility of using the diagnostics image in the input data
SNTP	2.10	Possibility to use SNTP

\* For more information on the system status, see the Section "Digital I/O and system status [► 36]"

### 8.2.3.1 Digital I/O and system status

#### System status IO layout in decimal and hexadecimal format

Bits	Value in decimal (dec)	Value in hexadecimal (hex)	Meaning
0	1	0x00 00 00 01	Sensor undervoltage
1	2	0x00 00 00 02	Actuator undervoltage
2	4	0x00 00 00 04	No actuator supply power
3	8	0x00 00 00 08	Reserved
4	16	0x00 00 00 10	Sensor short-circuit on at least one channel.
5	32	0x00 00 00 20	Actuator short-circuit at at least one channel.

Bits	Value in decimal (dec)	Value in hexadecimal (hex)	Meaning
6	64	0x00 00 00 40	Reserved
7	128	0x00 00 00 80	Reserved
8	256	0x00 00 01 00	Reserved
9	512	0x00 00 02 00	At least one IO-Link port has an error (except wire break)
10	1024	0x00 00 04 00	Sensor overvoltage
11	2048	0x00 00 08 00	Actuator overvoltage
12	4096	0x00 00 10 00	At least one IO-Link port has a wire break
13 - 31			Reserved

## Bit assignment of the system status IO layout binary

### Byte 3

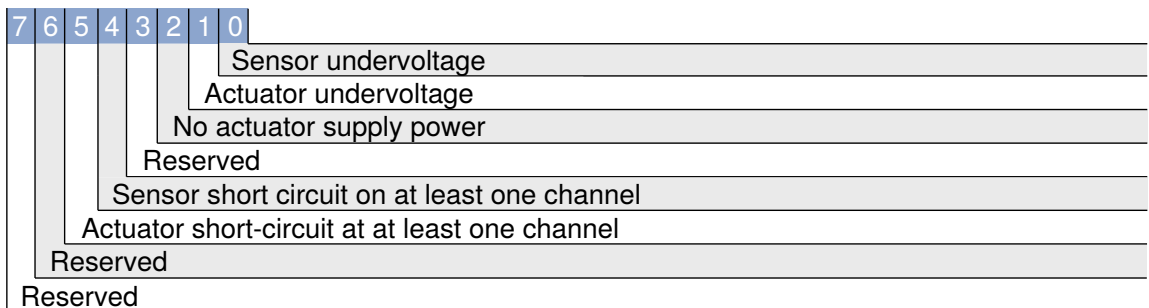

### Byte 2

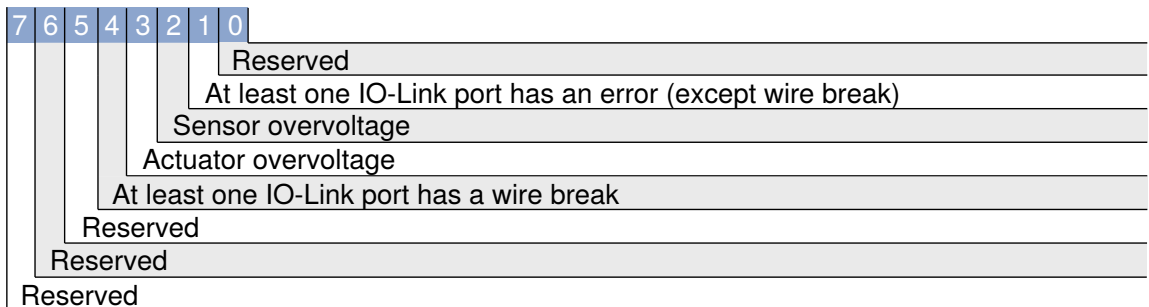

Byte 0 and byte 1 system status reserved

### 8.2.3.2 Diagnostic buffer

In the input data of the diagnostic buffer subslot, 8 diagnoses are mapped in the diagnostic fields 0...7 with 8 bytes each, a total of 64 bytes. If there are more diagnoses, the others are not shown. If there are less than 8 diagnoses, the 8 bytes of a diagnostic field in which no diagnostics is mapped are assigned 0.

### Diagnostics structure

The structure of a diagnostics in a diagnostics field is shown in the following table.

Byte	Meaning
0	Slot number

Byte	Meaning
1	Sub slot number
2	Channel number (0xFF: diagnostics affects complete slot)
3, Bit 0...1	ChannelProperties.Specifier
3, Bit 2...3	ChannelProperties.Severity
3, Bit 4...5	UserStructureIdentifier
3, Bit 6...7	Reserved
4...5	ChannelErrorType
6...7	ExtChannelErrorType

## Structure of the output data

The structure of the output data is shown in the following table.

Byte	Meaning
0	Confirmation of a diagnostics (1 bit per diagnostics, bit n: Diagnostics field n in the diagnostic buffer input data). <ul style="list-style-type: none"> <li>1. If the associated parameter “Enable diagnostic message acknowledgement” is activated, “outgoing” diagnoses remain in the diagnostic buffer until the corresponding bit field has been set in the output data.</li> <li>2. If the associated parameter “Enable diagnostic message acknowledgement” is not activated, diagnoses are removed from the diagnostic buffer as soon as the diagnostics is completed, without the corresponding bit field being set in the output data.</li> </ul>
1	Reserved

## 8.2.4 Addresses

Once the module has been assigned to an IO controller, the I/O addresses can be assigned according to the address assignment in the project.

It is also possible to change the I/O addresses manually.

The screenshot shows the Siemens TIA Portal interface. The main window displays a rack and slot configuration for an EP8P001 IO-Link Master module. The 'Device overview' table shows the module's rack and slot information. The 'Properties' window is open, showing the 'I/O addresses' section with input and output address ranges set to 0-1.

Module	Rack	Slot	I address	Q address	Type
EP8P001	0	0			EP8P001 IO-Link...
EP8P001 IO-Link Master ...	0	0 1			EP8P001
EP8P001 device_1	0	1	0...1	0...1	EP8P001 device
SIO data / Module param...	0	1 1	0...1	0...1	SIO data / Mod...
	0	1 X0 (...)			
	0	1 X1 (...)			
	0	1 X2 (...)			
	0	1 X3 (...)			
	0	1 X4 (...)			
	0	1 X5 (...)			
	0	1 X6 (...)			
	0	1 X7 (...)			

The 'Properties' window shows the following configuration for the 'I/O addresses' section:

**Input addresses**

Start address: 0  
End address: 1  
Organization block: --- (Automatic update)  
Process image: Automatische Aktualisierung

**Output addresses**

Start address: 0  
End address: 1  
Organization block: --- (Automatic update)  
Process image: Automatische Aktualisierung

## 8.3 Module Parameterization



### INFORMATION

The parameterization options are explained in this section.

The following modules are described

- EP8P001 Device
- EP8P001 Options

### 8.3.1 Module EP8P001 Device

#### Overview of Submodules

1. SIO data/Module parameters
2. Deactivated
3. Standard digital input
4. Standard digital output
5. Generic IO-Link modules
6. Profile Devices
7. ME devices

#### Submodule Assembly Parameters

No.	Submodule	Parameter no.	Parameters
1	SIO data/Module parameters	1	Pin/Port based
		2	Message Global diagnostics deactivated
		3	Bus/sensor supply undervoltage deactivated message
		4	Threshold value for bus/sensor supply undervoltage
		5	Undervoltage actuator supply deactivated message
		6	Actuator supply undervoltage threshold value activated message
		7	Actuator supply voltage failure deactivated message
		8	Suppressed diagnostics LED indicator enabled
		9	IO-Link diagnostics message
		10	Deactivation of US at pin 1
		11	SIO channel function pin 2
		12	Input delay pin 2
		13	Rated current for pin 1
		14	Rated current for pin 2
		15	Rated current for pin 4
		16	IO-Link diagnostics event integration
		17	Manual restart pin 2 after overcurrent
		18	Input value in the event of assembly failure
2	Deactivated	19	Port mode
		20	Input value in the event of assembly failure
3	Standard digital input	21	Pin 4 function
		22	Input delay pin 4

No.	Submodule	Parameter no.	Parameters
		23	Port diagnostics message
4	Standard digital output	24	Static output signal at pin 4
		25	Manual restart pin 4 during overcurrent
		26	Port diagnostics message
5,	Generic	27	Port diagnostics message
		28	Process alarm message
6,	IO-Link module,	29	Configuration via PDCT
		30	Input data split
7	Profile devices, ME devices	31	Pull/Plug diagnostics message
		32	Port mode
		33	Validity check/backup
		34	Cycle time
		35	Manufacturer ID
		36	Device ID

### 8.3.1.1 Submodule 1\_SIO data/Module parameters

#### Parameter 1

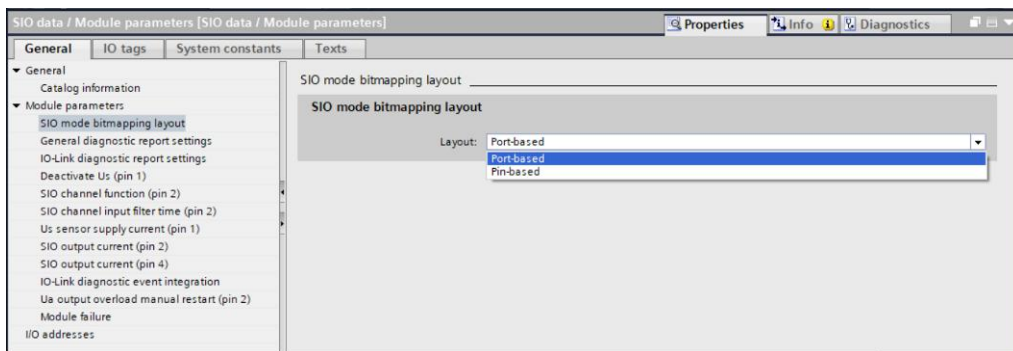

No.	Parameters	Selection (D-Default)	Meaning
1	Layout	Port-based (D)	Transfer of IO data in port-based format.
		Pin-based	Transfer of IO data in pin-based format.

#### Port-based I/O data/qualifier, DI/DO

I/O Byte 0							
Bit 0	Bit 1	Bit 2	Bit 3	Bit 4	Bit 5	Bit 6	Bit 7
Port X0	Port X0	Port X1	Port X1	Port X2	Port X2	Port X3	Port X3
Pin 4	Pin 2	Pin 4	Pin 2	Pin 4	Pin 2	Pin 4	Pin 4
I/O Byte 1							
Port X4	Port X4	Port X5	Port X5	Port X6	Port X6	Port X7	Port X7
Pin 4	Pin 2	Pin 4	Pin 2	Pin 4	Pin 2	Pin 4	Pin 4

#### Pin-based I/O data/qualifier, DI/DO

I/O Byte 0							
Bit 0	Bit 1	Bit 2	Bit 3	Bit 4	Bit 5	Bit 6	Bit 7
Port X0	Port X1	Port X2	Port X3	Port X4	Port X5	Port X6	Port X7
Pin 4	Pin 4	Pin 4	Pin 4	Pin 4	Pin 4	Pin 4	Pin 4
I/O Byte 1							

Port X4	Port X1	Port X2	Port X3	Port X4	Port X5	Port X6	Port X7
Pin 4	Pin 2	Pin 2	Pin 2	Pin 2	Pin 2	Pin 2	Pin 2

## Parameter 2-8

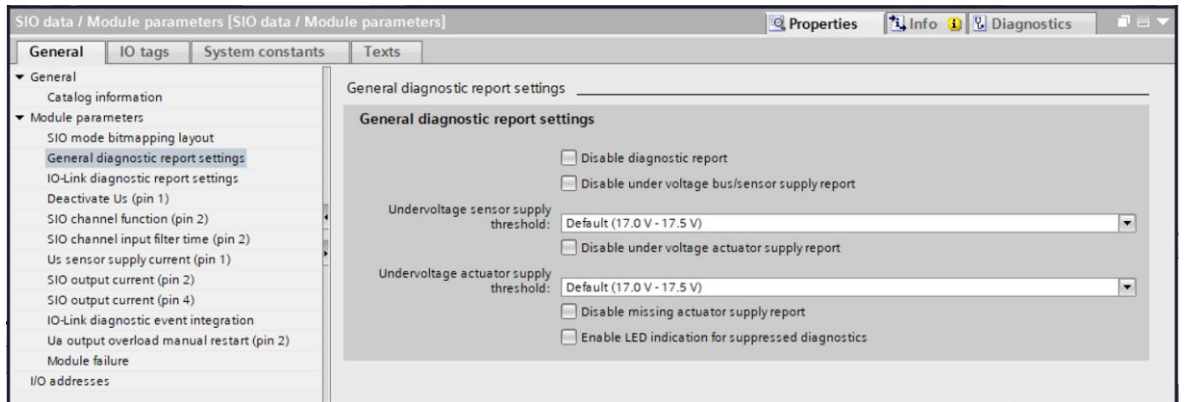

No.	Parameters	Selection (D-Default)	Meaning
2	Message Global diagnostics deactivated (Disable diagnostic report)	Off (D)	Diagnostic report is reported.
		On	Diagnostic report is not reported.
3	Undervoltage at bus and sensor supply power message Deactivated (Disable undervoltage bus/sensor supply report)	Off (D)	Bus/sensor supply undervoltage is reported.
		On	Bus/sensor supply undervoltage is not reported.
4	Threshold value, sensor supply undervoltage (Undervoltage sensor supply threshold)	17.0 ... 17.5 V (D)	The message appears in the selected area
		17.5 ... 18.0 V	
		18.5 ... 18.5 V	
		18.5 ... 19.0 V	
		19.0 ... 19.5 V	
		19.5 ... 20.0 V	
5	Undervoltage message Actuator supply deactivated (Disable missing actuator supply report)	Off (D)	Undervoltage at actuator supply power is reported.
		On	Undervoltage at actuator supply power is not reported.
6	Undervoltage threshold Actuator supply power (Undervoltage actuator supply threshold)	17.0 ... 17.5 V (D)	The message appears in the selected area.
		17.5 ... 18.0 V	
		18.5 ... 18.5 V	
		18.5 ... 19.0 V	
		19.0 ... 19.5 V	
		19.5 ... 20.0 V	
7	Power failure message Actuator supply deactivated (Disable missing actuator supply report)	Off (D)	Undervoltage at actuator supply power is reported.
		On	Undervoltage at actuator supply power is not reported.
8	Suppressed diagnostics LED indicator Activated (Enable LED indication for suppressed)	Off (D)	Suppressed diagnostics LED indicator disabled.
		On	Suppressed diagnostics LED indicator activated.

No.	Parameters	Selection (D-Default)	Meaning
	diagnostics)		

## Parameter 9

The screenshot shows the 'IO-Link diagnostic report settings' configuration window. The left sidebar lists various parameters, with 'IO-Link diagnostic report settings' selected. The main area displays a list of IO-Link master ports (X0 to X7) with dropdown menus for selecting the diagnostic report level for each port. The dropdown for X2 is expanded, showing three options: 'Report all diagnostics', 'Report all diagnostics except wire break', and 'Report only wire break diagnostics'.

No.	Parameters	Selection (D-Default)	Meaning
9	IO-Link diagnostics message (IO-Link master port)	Report all diagnostics	All diagnoses are displayed
		Report all diagnostics except wire break	No line break diagnoses are displayed.
		Report only wire break diagnostics	Only line break diagnoses are displayed.

## Parameter 10

The screenshot shows the 'Deactivate Us (pin 1)' configuration window. The left sidebar lists various parameters, with 'Deactivate Us (pin 1)' selected. The main area displays a list of IO-Link master ports (X0 to X7) with checkboxes for selecting the deactivation setting for each port. All checkboxes are currently unchecked.

No.	Parameters	Selection (D-Default)	Meaning
10	Deactivation of US at pin 1 (Deactivate Us (pin1))	Off (D)	Pin1 carries +24 V DC for e.g. power supply of sensors.
		On	Pin 1 has no voltage!



## INFORMATION

The setting for individual ports is freely selectable.

## Parameter 11

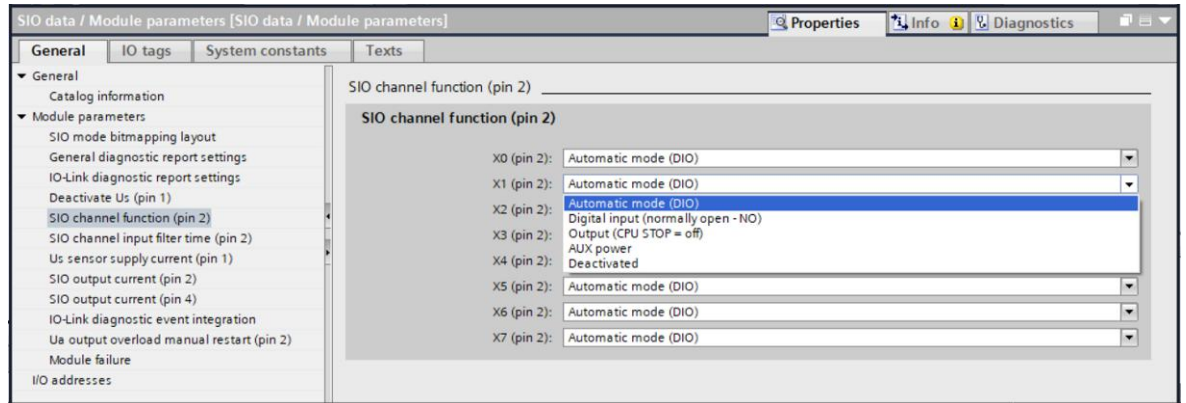

No.	Parameters	Selection (D-Default)	Meaning
11	SIO channel function pin 2 (SIO channel function (pin 2))	Automatic mode (D)	Automatic configuration (automatic detection input or output).
		Digital input (normally open NO)	Input NO
		Output (CPU STOP =off)	Output
		AUX power	Static +24 V DC for power supply of Class B devices.
		Deactivated	Deactivated

## Parameter 12

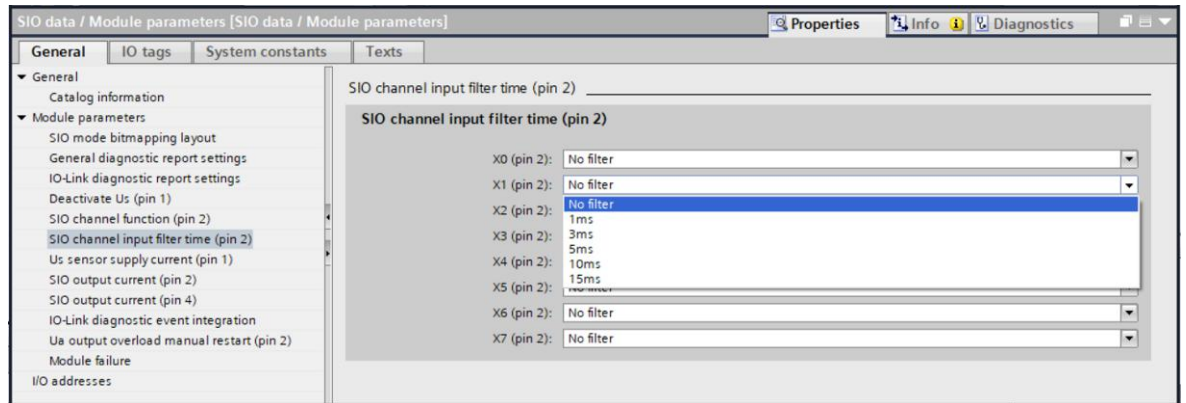

### INFORMATION

The input delay represents a filter that only detects input signals as high at the time X.

No.	Parameter	Selection (D-Default)	Meaning
12	Input delay pin 2 (SIO channel input filter time (pin 2))	No filter (D)	No input delay
		1 ms	Input delay 1 ms
		3 ms	Input delay 3 ms
		5 ms	Input delay 5 ms
		10 ms	Input delay 10 ms
		15 ms	Input delay 15 ms

## Parameter 13

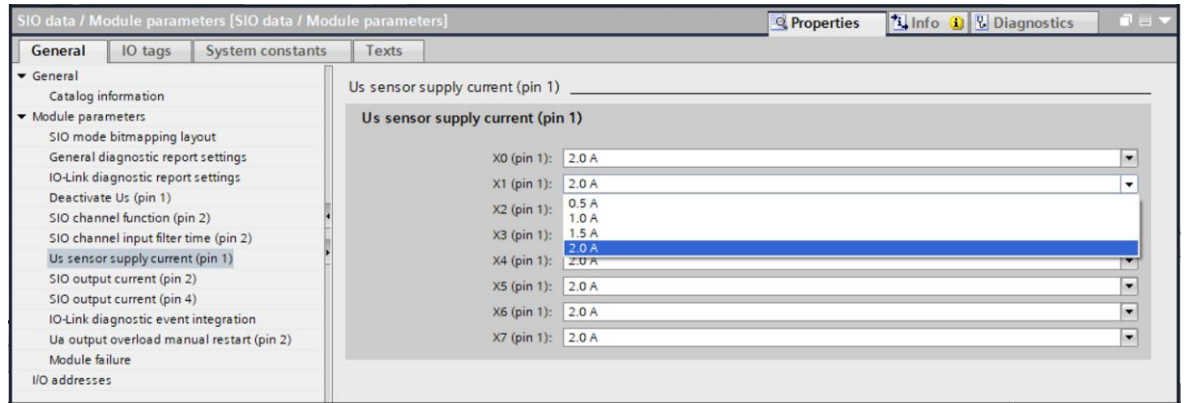

No.	Parameter	Selection (D-Default)	Meaning
13	Input delay pin 2 (SIO channel input filter time (pin 2))	2.0 A (D) 1.5 A 1 A 0.5 A	Pin is switched off at an overload of 125%.

## Parameter 14

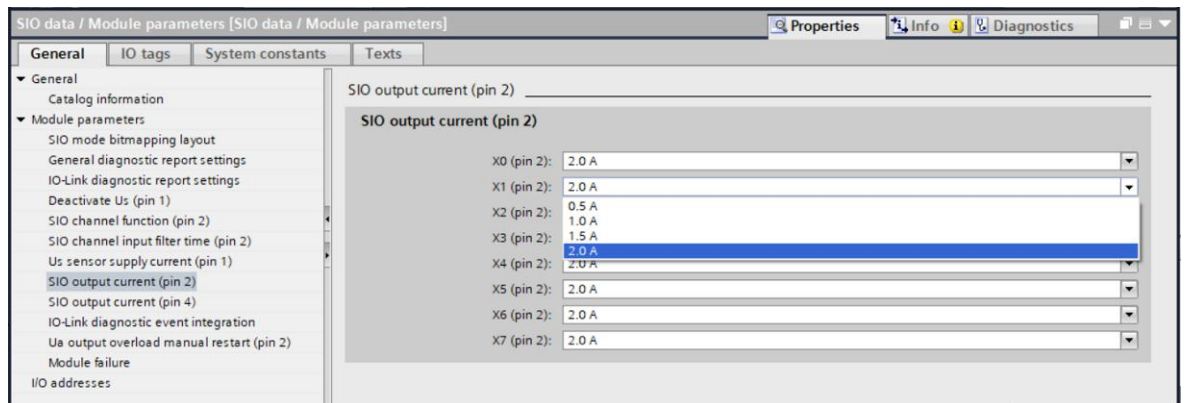

No.	Parameter	Selection (D-Default)	Meaning
14	Rated current for pin 2 at output (SIO output current (pin 4))	2.0 A (D) 1.5 A 1 A 0.5 A	Pin is switched off at an overload of 125%.

## Parameter 15

The screenshot shows the 'SIO data / Module parameters' window with the 'SIO output current (pin 4)' parameter selected. The parameter is configured for all pins (X0 to X7) to be 2.0 A. The interface includes tabs for 'General', 'IO tags', 'System constants', and 'Texts'. The left sidebar lists various module parameters, and the main area shows the selected parameter with a list of pins and their corresponding current values.

No.	Parameter	Selection (D-Default)	Meaning
15	Rated current for pin 4 at output (SIO output current (pin 4))	2.0 A (D) 1.5 A 1 A 0.5 A	Pin is switched off at an overload of 125%.



## INFORMATION

The parameters for ports X0 to X7 can be freely selected.

## Parameter 17

The screenshot shows the 'SIO data / Module parameters' window with the 'Ua output overload manual restart (pin 2)' parameter selected. The parameter is configured for all pins (X0 to X7) to be 'Off'. The interface includes tabs for 'General', 'IO tags', 'System constants', and 'Texts'. The left sidebar lists various module parameters, and the main area shows the selected parameter with a list of pins and their corresponding restart settings.

No.	Parameters	Selection (D-Default)	Meaning
17	Manual restart pin 2 after overcurrent (Ua output overload manual restart (pin 2))	Off (D) On	The error is automatically logged off after approximately 10 seconds, after which it no longer occurs.  The fault is not cleared until the relevant output signal is manually set to 0.  <b>This functionality is currently not available. Therefore, this value cannot be selected.</b>

## Parameter 18

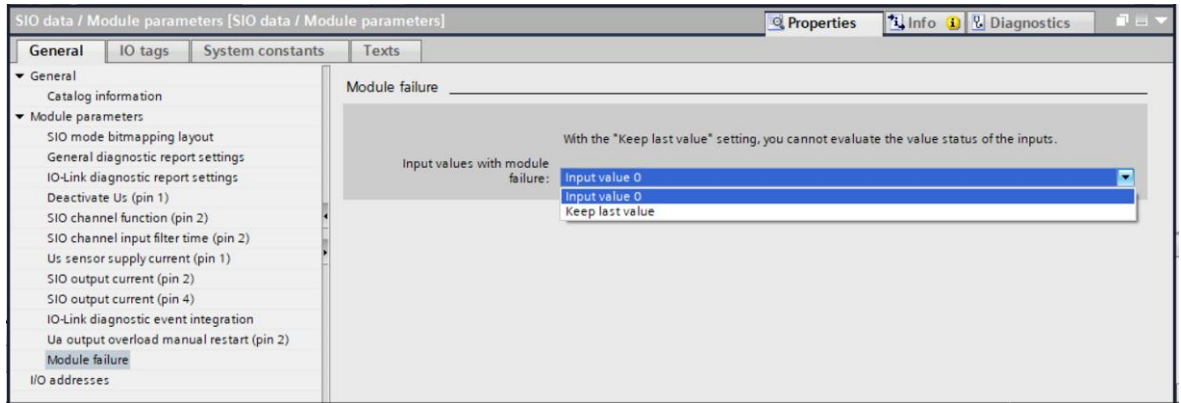

No.	Parameters	Selection (D-Default)	Meaning
18	Input values with module failure (Input values with module failure)	Input value 0 (D) (Input value 0)	The input value is always set to 0.
		Last value (Keep last value)	The last input value is retained.

### 8.3.1.2 Submodule 2\_Deactivated

## Parameter 19 – 20

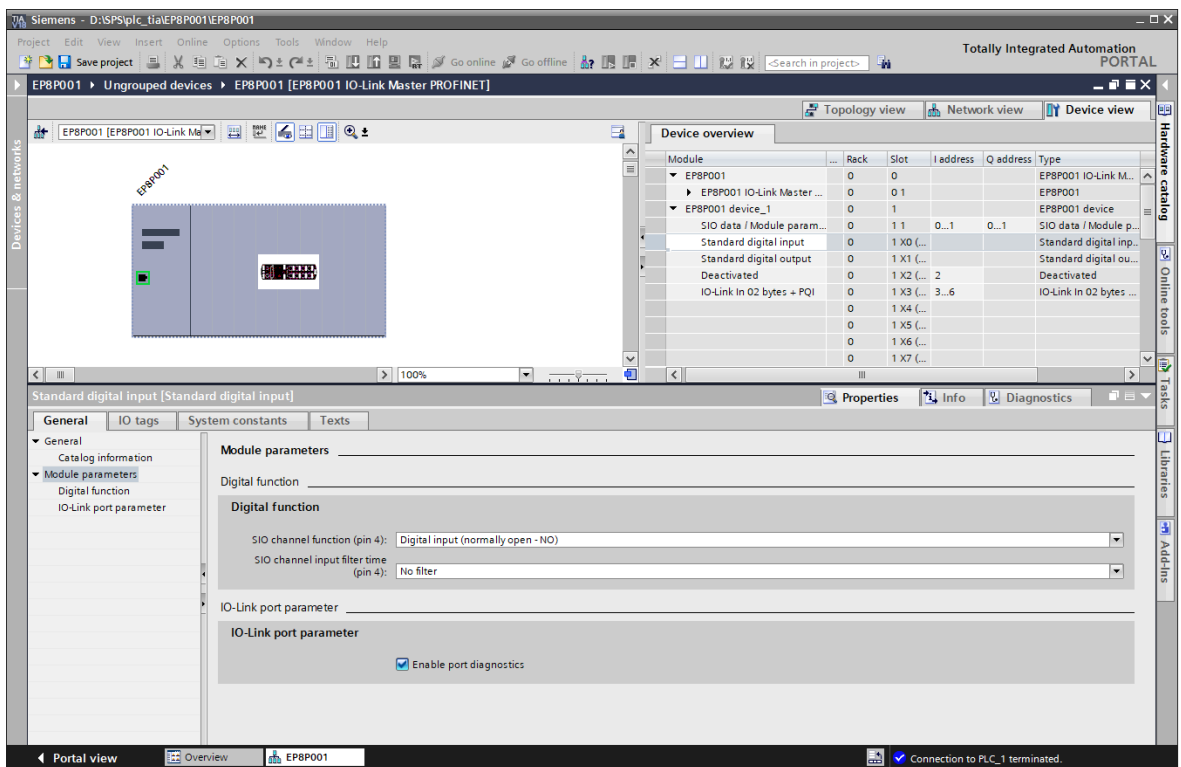

No.	Parameter	Selection (D-Default)	Meaning
19	Port mode (Port mode)	Deactivated (D)	<b>Parameter cannot be changed!</b>
20	Input value in the event of assembly failure (Input values with module failure)	Input value 0 (D) (Input value 0)	The input value is always set to 0.
		Last value (Keep last value)	The last input data value is used and is not overwritten with 0.

### 8.3.1.3 Submodule 3\_Standard digital input

#### Parameter 21 – 23

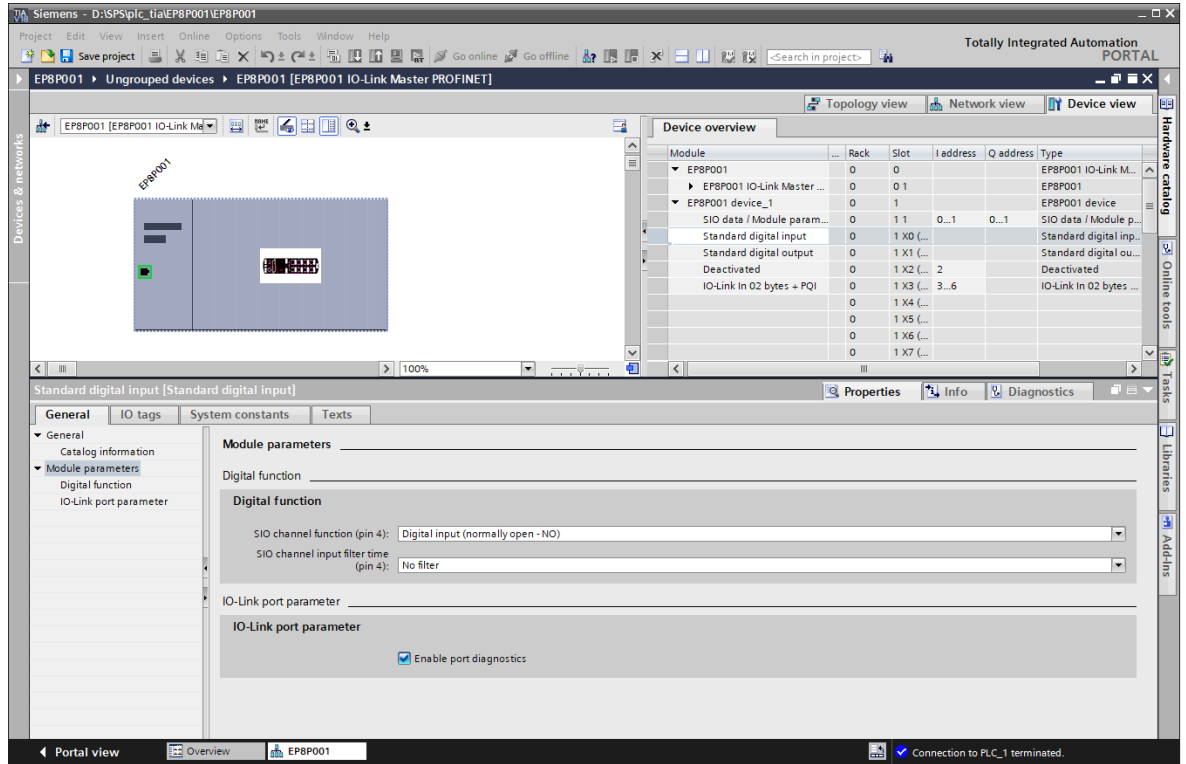

No.	Parameters	Selection (D-Default)	Meaning
21	Pin 4 function (SIO channel function (pin 4))	Digital input (NC NO) (D) Digital input (NO NC)	NC or NO
22	Input delay pin 4 (SIO channel input filter time (pin 4))	No filter (No filter)	The input delay represents a filter that only detects input signals as high at the time X.
23	Port diagnostics message (IO-Link port parameter)	Enable port diagnostics On (D)	IO-Link device and IO-Link master errors are reported.
		Enable port diagnostics Off	IO-Link device and IO-Link master errors are not reported.

### 8.3.1.4 Submodule 4\_Standard digital output

#### Parameter 24 – 26

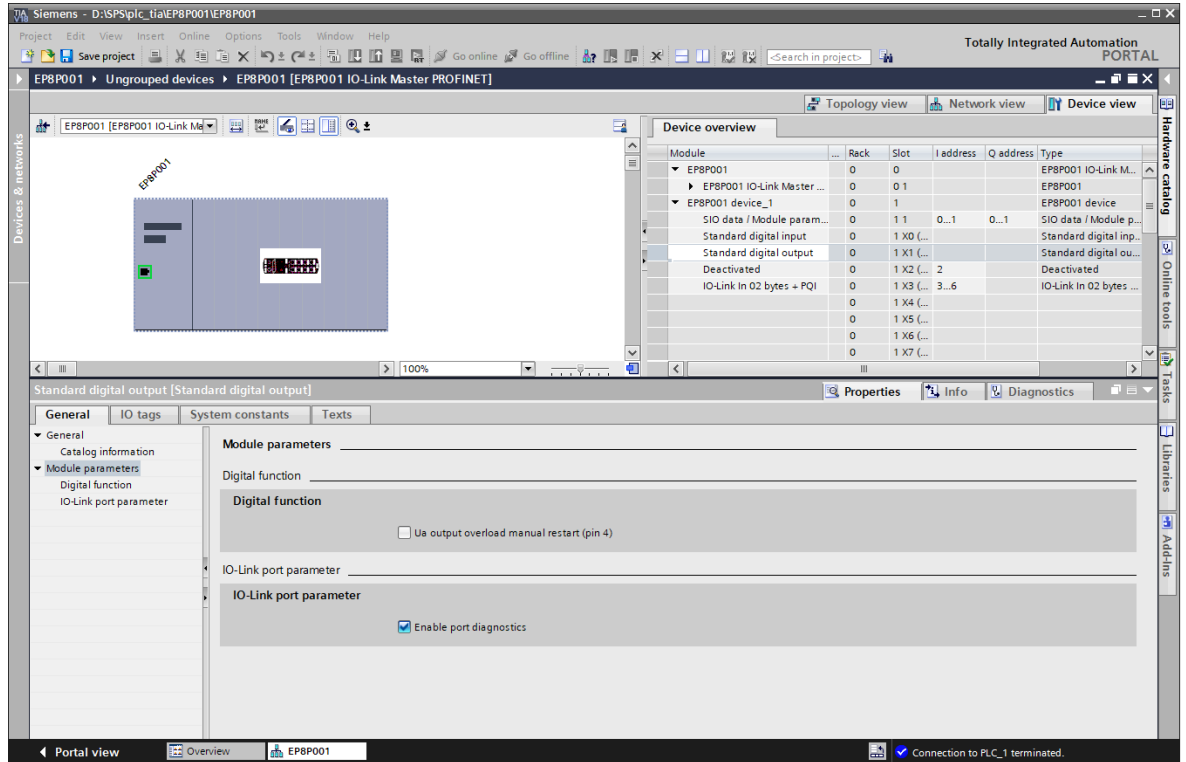

No.	Parameters	Selection (D-Default)	Meaning
24	Reserved	-	-
25	Manual restart pin 4 after overcurrent (Ua output overload manual restart (pin 4))	Off (D)	The error is automatically deactivated approximately 10 seconds after which it has no longer occurred.
		On	The fault is not cleared until the relevant output signal has been manually set to 0. <b>This functionality is currently not available. Therefore, this value cannot be selected.</b>
26		Enable port diagnostics	All IO-Link device and IO-Link master errors are reported.
		On (D)	
		Enable port diagnostics	IO-Link device and IO-Link master errors are not reported.
		Off	

### 8.3.1.5 Submodules 5, 6, 7

- Submodule 5 Generic IO-Link modules
- Submodule 6 Profile devices
- Submodule 7 ME devices

## Parameter 27 – 36

No.	Parameters	Selection (D-Default)	Meaning
27	Port diagnostics message (Enable port diagnostics)	Off	IO-Link port diagnostics is not reported.
		On (D)	IO-Link port diagnostics is reported.
28	Message of process alarm (Enable process alarm (device notification))	Off	Process alarm is not reported.
		On (D)	Process alarm is reported.
29	Configuration via PDCT (Enable configuration via PDCT (Port and Device Configuration Tool))	Off	Configuration via PDCT not possible.
		On (D)	Configuration via PDCT possible.
30	Input data split (Enable input fraction)	Off (D)	Input data length of connected device is checked.
		On	The length of the input data of the connected device may exceed the configured length. In this case, however, no error message is output. For more information, see "IO-Link data length"
31	Pull/Plug diagnostics message (Enable pull/plug diagnostics)	Off (D)	Pull/Plug diagnostics is not reported if <ul style="list-style-type: none"> <li>the connection of an IO-Link device is lost</li> <li>a device has been detected.</li> </ul>
		On	Pull/plug diagnostics is reported if

No.	Parameters	Selection (D-Default)	Meaning
			<ul style="list-style-type: none"> <li>the connection of an IO-Link device is lost</li> </ul> b   a device has been detected.
32	Port mode (Port mode)*	Autostart (D)	IO-Link mode. No validity check and no setting of filter times possible.
		Manual	IO-Link mode. No validity check and no setting of filter times possible.
		Deactivated	Deactivated
33	Validity check/backup (Validation/Backup)*	No device check (D)	Validity check is not performed
		Type compatible device (1.0)	Validity check is performed if Port Mode is set to Manual. Test is performed on IO-Link version 1.0. If a device is not compatible, a diagnostics is output.
		Type compatible device (1.1)	Validity check is performed if Port Mode is set to Manual. Test is performed on IO-Link version 1.1. If a device is not compatible, a diagnostics is output.
		Type compatible V1.1 device with backup + restore	Validity check is performed if Port Mode is set to Manual. Test is performed on IO-Link version 1.0. If a device is not compatible, a diagnostics is output.  Restore+Backup behavior as defined in the IO-Link specification, see <b>"IO-Link-DataStorage. Restore option"</b>
		Type compatible V1.1 device with restore	Validity check is performed if Port Mode is set to Manual. Test is performed on IO-Link version 1.0. If a device is not compatible, a diagnostics is output.  Restore behavior as defined in the IO-Link specification.
34	Cycle time (Port cycle time), see "Cycle time parameters"	As fast as possible (D) (As fast as possible)	The master and the connected IO-Link module automatically determine the shortest cycle time.
		3.2 ms	Named filter time
		4.8 ms	Named filter time
		6.4 ms	Named filter time
		8.0 ms	Named filter time
		10 ms	Named filter time
		12 ms	Named filter time
		16 ms	Named filter time
		20 ms	Named filter time
		40 ms	Named filter time
		80 ms	Named filter time
120 ms	Named filter time		
35	Manufacturer ID (Vendor ID)*	00, 00	Manufacturer ID of the IO-Link device to be used. Used in the validity check.

No.	Parameters	Selection (D-Default)	Meaning
		2 byte list, byte by byte, values separated by comma and in hexadecimal format	
36	Device ID (Device ID)*	00, 00, 00 3 byte list, byte by byte, values separated by comma and in hexadecimal format	Device ID of the IO-Link device to be used. Used in the validity check.

### \*Submodule 7 ME devices

In submodule 7 “ME devices”, the connected device must be checked for validity. Therefore, there are the following restrictions when selecting parameters:

#### Port mode

- The “Port Mode” parameter is set to “Manual” by default.

#### Validity check/backup

- The “Validity check/backup” parameter is preset to “Type compatible device (1.1)”. You can only select between “Type compatible device (1.1)” and “Type compatible device (1.0)”.

#### Manufacturer ID

- The “Manufacturer ID” parameter is set to the ID of the described device.

#### Device ID

- The “Device ID” parameter is fixed to the ID of the described device.



## INFORMATION

If the “Manual” option is selected for the “Port mode” parameters, the following parameters can be applied:

- Cycle time (Port cycle time)
- Validity check/backup (validation/backup)
- Manufacturer ID (Vendor ID)
- Device ID (Device ID)

If the “Autostart (D)” option is selected for the “Port mode” parameter, the minimum IO-Link cycle time specified by the IO-Link device is used and no compatibility check takes place.

### IO-Link data length



## INFORMATION

Different IO-Link data lengths are transmitted to Profinet without generating an error.

In this case, part of the input data is also forwarded via Profinet. Let’s assume that a sensor can have different input lengths, 4, 6 and 8 bytes, depending on the parameterization or profile. In Profinet, you can configure a submodule with 4 bytes input and activate the “enable input fraction” parameter. Thus, there is no mismatch alarm and the first 4 bytes from the sensor are mapped to Profinet. The other bytes are then ignored. Use case would be, for example, IOL sensor, which can provide additional diagnostic input bytes, these would be ignored in Profinet if they are irrelevant for the PLC/machine. However, the data would then be available in other ways, e.g. OPC UA, MQTT, JSON.

## IO-Link data storage. Restore option



### INFORMATION

When switching to the “Restore” state, any device configurations previously saved in the device are discarded, especially when switching from “Backup & Restore” to “Restore”. If a compatible device is connected for the first time in the “Restore” state:

- the master retrieves the data storage data (one-time backup) from the device once,
- saves them and
- sends this data consecutively to each newly connected compatible device with a different configuration (Restore). Consequences

### Cycle time parameter

#### Cycle time for communication

Selection (D = default)	Meaning
As fast as possible (D)	The master and the IO-Link device automatically determine the fastest cycle time.
3.2 ... 128.0 ms	Set the cycle time to this value.

The cycle time parameter defines the cycle time to be used for communication between the IO-Link master and the IO-Link device.

For most use cases, “As fast as possible” is the best choice. When establishing the connection, the master and the device select the shortest possible cycle time.

Under certain circumstances (e.g. when using inductive couplers or other devices that are switched between the master and the IO-Link device), it may be necessary to set the cycle time manually.

In these cases, it may be necessary to select a fixed cycle time (which both the master and the device must support) to correct this problem.

For more information about the bits used by the generic IO-Link devices, see section “IO-Link port [► 33]”

## 8.3.2 Module EP8P001 options

### Overview of Submodule

1. Qualifier DI
2. Qualifier DO
3. System status
4. MQTT
5. OPC UA
6. JSON
7. Web server
8. Output forcing
9. Diagnostic buffer
10. SNTP

### Submodule Assembly Parameters

No.	Submodule	No.	Parameters
1	Qualifier DI	37	Input value in the event of assembly failure
2	Qualifier DO		
3	System status		

No.	Submodule	No.	Parameters
4		38	Activate
		39	Server IP address
		40	Client ID
		41	Client head topic
		42	Topic for system data
5	OPC UA	43	Activate
		44	TCP port number
		45	Writing ISDU data
		46	Writing PDO data
6	JSON	47	Activate
7	Web server	48	Activate
8	Output forcing	49	Forcing rules
9	Diagnostic buffer	37	Input value in the event of assembly failure
		50	Activate
10	SNTP	51	Server IP address
		52	Fallback server IP address

### 8.3.2.1 Submodules 1–3

- Submodule Qualifier DI
- Submodule Qualifier DO
- Submodule system status

### Parameter 37

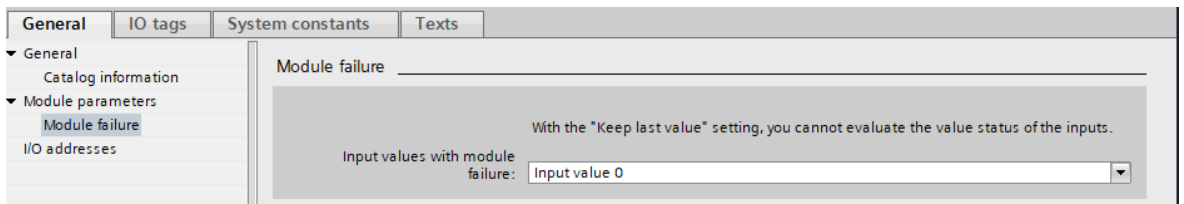

No.	Parameters	Selection (D-Default)	Meaning
37	Input values with module failure (Input values with module failure)	Input value 0 (D) (Input value 0)	The input value is always set to 0.
		Last value (Keep last value)	The last input data value is used and is not overwritten with 0.

### 8.3.2.2 Submodule 4\_MQTT

### Parameter 38

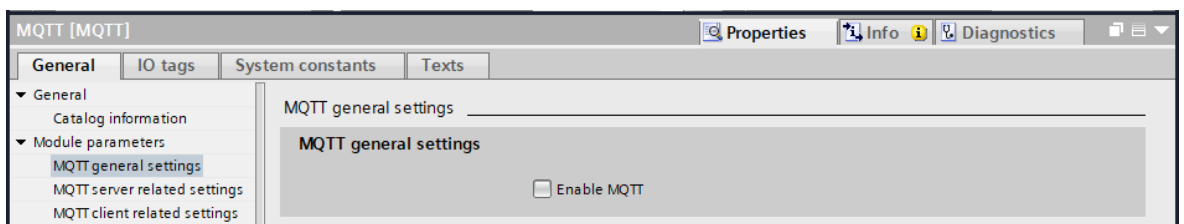

No.	Parameters	Selection (D-Default)	Meaning
38	Activation MQTT	Off (D)	MQTT is not available.

No.	Parameters	Selection (D-Default)	Meaning
	(Enable MQTT)	On	MQTT is available.

### Parameter 39

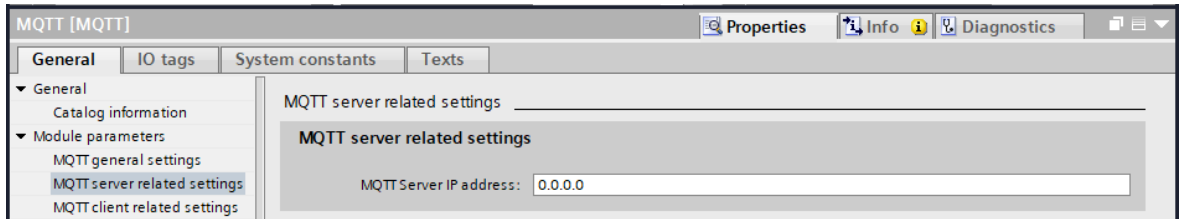

No.	Parameters	Selection (D-Default)	Meaning
39	MQTT server IP address	0.0.0.0	IP address of the MQTT server

### Parameter 40-42

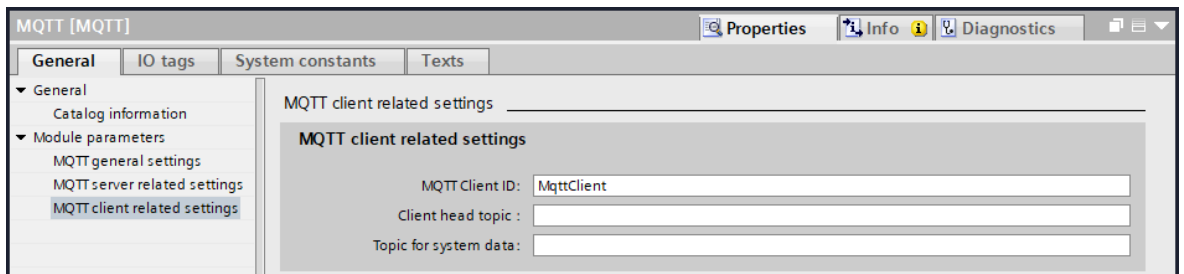

No.	Parameters	Selection (D-Default)	Meaning
40	MQTT Client ID	MqttClient	ID of the MQTT Client
41	Client head topic		Client head topic
42	Topic for system data		<b>Unused</b>

## 8.3.2.3 Submodule 5 OPC UA

### Parameter 43-46

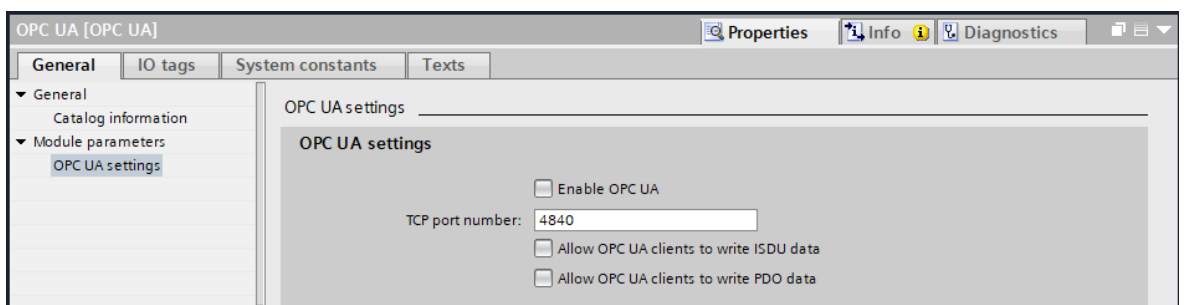

No.	Parameters	Selection (D-Default)	Meaning
43	OPC UA activation (Enable OPC UA)	Off (D)	Deactivated OPC UA is <i>not</i> available.
		On	Activated. OPC UA is available.
44	TCP port number (TCP port number)	4840	TCP port number

No.	Parameters	Selection (D-Default)	Meaning
45	Writing ISDU data via the OPC UA client (Allow OPC UA clients to write ISDU data)	Off (D)	Deactivated
		On	Activated
46	Writing PDO data via the OPC UA client (Allow OPC UA clients to write PDO data)	Off (D)	Deactivated
		On	Activated

### 8.3.2.4 Submodule 6\_JSON

#### Parameter 47

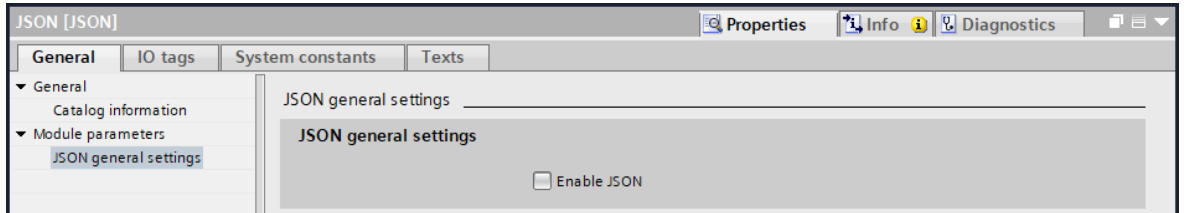

No.	Parameters	Selection (D-Default)	Meaning
47	Activation JSON (Enable JSON)	Off (D)	Deactivated JSON is not available.
		On	Activated. JSON is available.

### 8.3.2.5 Submodule 7\_Webserver

#### Parameter 48

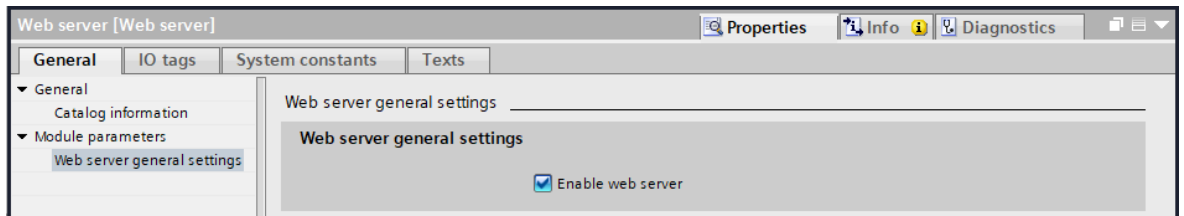

No.	Parameters	Selection (D-Default)	Meaning
48	Web server activation (Enable web server)	Off (D)	Deactivated The web server is not available.
		On	Activated. Web server is available.

### 8.3.2.6 Submodule 8\_Output forcing

#### Parameter 49

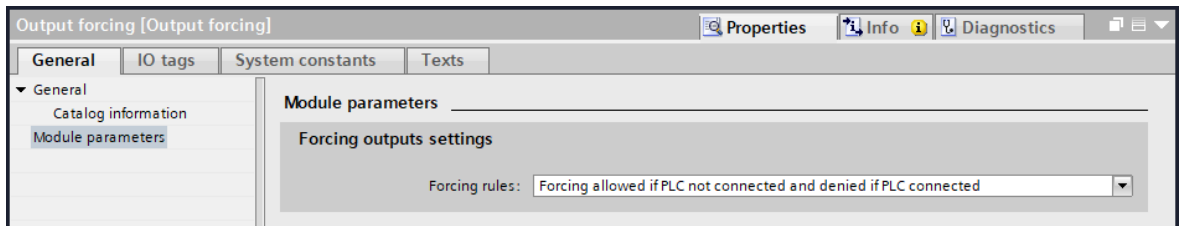

### INFORMATION

#### Output forcing:

Instead of the process data from the controller, the data set via output forcing is forwarded to the outputs. Output forcing is possible via the website or via OPC UA.

Activation of output forcing is only possible if the set preconditions (forcing rules) are met.

No.	Parameters	Selection (D-Default)	Meaning
49	Connections (Forcing rules)	Output forcing: <ul style="list-style-type: none"> <li>Allowed if PLC not connected</li> <li>Not allowed if PLC connected (D)</li> </ul>	Output forcing of the output data is only allowed if the PLC is not connected.
		Output forcing allowed	Output forcing is <i>always allowed</i> , regardless of the PLC connection status.
		Output forcing not allowed	Output forcing is <i>never allowed</i> regardless of the PLC connection status.

### 8.3.2.7 Submodule 9\_Diagnosepuffer

#### Parameters 37, 50

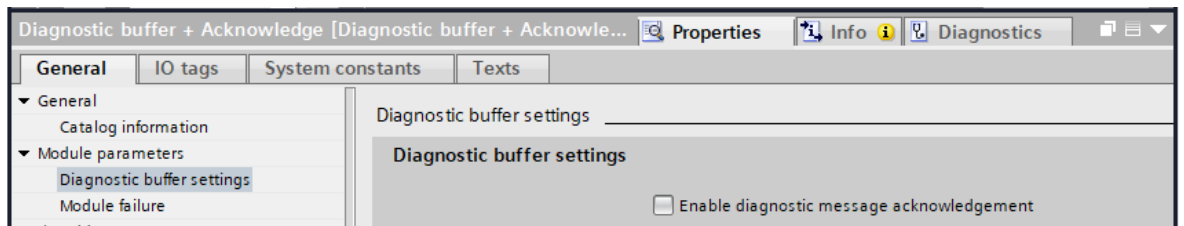

No.	Parameters	Selection (D-Default)	Meaning
37	Input value in the event of assembly failure (Input values with module failure)	Input value 0 (D) (Input value 0)	The input value is always set to 0.
		Keep last value (Keep last value)	The last input data value is used and is not overwritten with 0.
50	Enable diagnostic message acknowledgement (Enable diagnostic message acknowledgement)	Off (D)	Activation is not available
		On	Activation is available

### 8.3.2.8 Submodule 10\_Sntp

#### Parameters 51, 52

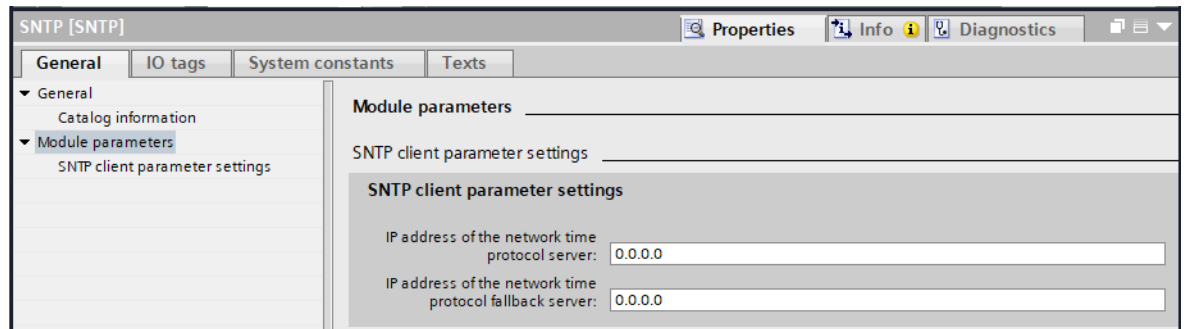

No.		Selection (D-Default)	Meaning
51	IP address of the network time protocol server	0.0.0.0	IP address of the NTP server
52	IP address of the network time protocol fallback server	0.0.0.0	IP address of the NTP fallback server

## 8.4 IO-Link Configuration

The EP8P001 module allows the configuration and parameterization of IO-Link devices in two different ways:

1. IO-Link integration in the GSDML
2. IO-Link integration in PROFINET

### IO-Link Integration in the GSDML

If the IO-Link device is available in the GSDML of the EP8P001, the IO-Link device can be inserted into the configuration as a subslot instead of an IO-Link submodule.

The IO-Link device can then be parameterized like a comparable subslot in the configuration of your engineering software.

### IO-Link Integration in PROFINET

IO-Link integration in PROFINET is a standardized method for accessing parameters and configurations of IO-Link devices using PROFINET interfaces.

The EP8P001 module supports the integration of V1.0 Edition 2.

## 8.5 Cyclic and Acyclic Communication

The IO-Link specification defines three types of data that are exchanged between the IO-Link master and the IO-Link device:

- Cyclic process data (process data objects input/output)
- Acyclic data in the form of device data (on-request data objects)
- Acyclic data as events

The process data objects and their status information (port qualifier) are transmitted cyclically after communication has been established.

The transmission time can be individually configured as the IO-Link cycle time for each IO-Link port, see section "Submodules 5, 6, 7 [▶ 48]".

The process data of the connected device can be between 0 and 32 bytes (input and output respectively) and are transmitted via the set address ranges.

The process data size is determined by the device. The port qualifier indicates whether the process data is valid.

Device data (on-request data objects) are:

- Device parameters
- I&M records (Identification & Maintenance)
- Diagnostics information

Device data can be written to the device as parameters or read out from the device as device statuses.

The transmission takes place acyclically and only at the request of the IO-Link master. IO-Link events are error messages and warnings/maintenance data.

If the device sets the event flag, the IO-Link master retrieves the diagnostic data from the device. The EP8P001 device forwards the diagnostic data to the control system via the fieldbus.

Further information on device diagnostics and IO-Link event codes is described in section “According to IO-Link Integration Guideline Issue 2 [▶ 102]”.

## 8.5.1 IO-Link Acyclic Accesses

Acyclic access to various data areas in the IO-Link master or access to the data of the IO-Link devices takes place via PN-IO Read/Write Services:

- Read/Write Services for I&M data in the master and IO-Link devices.
- IO-Link function block IOL\_Call with ISDU (Index Service Data Unit) IOL\_Index 0x0000 – 0x7FFF and IOL\_Subindex 0x00 – 0xFF

(See: IO-Link Integration-Part1-2812\_V100\_080124 and IO-Link Integration-for-PROFINET\_Ed2\_2832\_V10\_Jun17).

The IO-Link function block supports the following tasks:

- Parameterization of an IO-Link device,
- Diagnostics of an IO-Link device,
- Execution of IO-Link port functions,
- Backup and restore of IO-Link device parameters.

The IO-Link function module is provided by the control system manufacturer (e.g. Siemens-FB IO\_Link\_Device for TIA Portal), IO-Link Function Block [▶ 60]



### INFORMATION

For more information, refer to the control manufacturer's manual.

## 8.5.2 I&M Data

I&M data can be read out acyclically at any time to identify devices installed in the system. The plant-specific description of location, function and installation date can be written to the module.

The module supports the following I&M records:

- IM\_Index = 0xAFF0 -> Read access to IM0 IOL\_M
- IM\_Index = 0xAFF1 -> Read access to IM1 IOL\_M
- IM\_Index = 0xAFF2 -> Read access to IM2 IOL\_M
- IM\_Index = 0xAFF3 -> Read access to IM3 IOL\_M
- IM\_Index = 0xAFF4 -> Read access to IM4 IOL\_M
- IM\_Index = 0xB063 -> Read access to IOL\_M Directory

### I&M 0 (Slot 0, Index 0xAFF0)

I&M Data	Size in bytes/access (read/write)	Description
Vendor ID	2 / r	Manufacturer ID
OrderID	20 / r	Product name
IM_Serial_Number	16 / r	Serial number of device
IM_Hardware_Revision	2 / r	Device hardware revision
IM_Software_Revision	4 / r	Device software revision (V0.0.0)
IM_RevisionCounter	2 / r	Revision counter
IM_Profile_ID	2 / r	ID of the IO-Link submodule profile (API = 0x4E01)
IM_Profile_Specific_Type	2 / r	Additional value for profiles (= 0 unused)
IM_Version	2 / r	I&M version (default 0x0101)
IM_Supported	2 / r	Supported I&M data records (e.g. 0x0001 -> only I&M0 supported)

### I&M1 (Slot0, Index 0xAFF1)

I&M Data	Size in bytes/access (read/write)	Description
TagFunction of submodule	32 / r/w	Function of the device
TagLocation of submodule	22 / r/w	Location of the device in the plant

### I&M 0 (Slot 0, Index 0xAFF0)

I&M Data	Size in bytes/access (read/write)	Description
Installation_Date	16 / r/w	Device installation date

### I&M 0 (Slot 0, Index 0xAFF0)

I&M Data	Size in bytes/access (read/write)	Description
Descriptor	54 / r/w	Device description

### Read I&M Data Record

Function block RDREC\_Instance in the TIA Portal

Website: <https://support.industry.siemens.com/>

Example: I&M Index 0xAFF0

```

IF... CASE... FOR... WHILE... (*...*) REGION
OF... TO DO.. DO...

1 // -----
2 // I&M Read
3 //
4 "RDREC_Instance" (REQ:=#PARA_RDREC.REQ,
5     ID:=283,
6     INDEX:=16#AFF0,
7     MLEN:=#PARA_RDREC.MLEN,
8     VALID=>#PARA_RDREC.VALID,
9     BUSY=>#PARA_RDREC.BUSY,
10    ERROR=>#PARA_RDREC.ERROR,
11    STATUS=>#PARA_RDREC.STATUS,
12    LEN=>#PARA_RDREC.LEN,
13    RECORD:=#PARA_RDREC.RECORD);
14

```

RDREC block	Functionality
RDREC_Instance	This function block is used to read I&M data acyclically via the S7 program

### 8.5.3 IO-Link Function Block

Function block IO\_LINK\_DEVICE in the TIA Portal The IO-Link function block is contained in the library "IO\_LINK\_Library\_V14.zal14".

Library	Website
IO_LINK_Library_V14.zal14	<a href="https://support.industry.siemens.com/">https://support.industry.siemens.com/</a>

The function block "IO\_LINK\_DEVICE" in the TIA Portal is based on the IOL\_CALL block. IOL\_CALL is defined in the IO-Link specification.

// IO-Link Call Block					
*LIOLink_Device_DB*.execute	Bool		TRUE	<input checked="" type="checkbox"/>	Request Function = true
*LIOLink_Device_DB*.hwID	DEC		265	<input checked="" type="checkbox"/>	HWID of Slot 1,1
*LIOLink_Device_DB*.cap	DEC		46080	<input checked="" type="checkbox"/>	CAP 0xB400 / 46080
*LIOLink_Device_DB*.readWrite	Bool		FALSE	<input checked="" type="checkbox"/>	Read = false, Write = true
*LIOLink_Device_DB*.port	DEC		8	<input checked="" type="checkbox"/>	X0 to X7 + 1 = Port
*LIOLink_Device_DB*.index	DEC		24	<input checked="" type="checkbox"/>	Index of the device
*LIOLink_Device_DB*.subindex	DEC		0	<input checked="" type="checkbox"/>	Subindex of the Index
*LIOLink_Device_DB*.writeLen	DEC		0	<input checked="" type="checkbox"/>	Data length (only write)
// STATUS					
*LIOLink_Device_DB*.error	Bool			<input type="checkbox"/>	
*LIOLink_Device_DB*.busy	Bool			<input type="checkbox"/>	
*LIOLink_Device_DB*.done	Bool			<input type="checkbox"/>	
*LIOLink_Device_DB*.readLen	DEC+/-			<input type="checkbox"/>	
// DATA					
*LIOLink_Device_Data*.IO-Link DATA*[0]	Character			<input type="checkbox"/>	
*LIOLink_Device_Data*.IO-Link DATA*[1]	Character			<input type="checkbox"/>	
*LIOLink_Device_Data*.IO-Link DATA*[2]	Character			<input type="checkbox"/>	
*LIOLink_Device_Data*.IO-Link DATA*[3]	Character			<input type="checkbox"/>	
*LIOLink_Device_Data*.IO-Link DATA*[4]	Character			<input type="checkbox"/>	
*LIOLink_Device_Data*.IO-Link DATA*[5]	Character			<input type="checkbox"/>	

IO-Link block	Functionality
IO_LINK_DEVICE	Using this function block,

IO-Link block	Functionality
	<ul style="list-style-type: none"> <li>• device parameters are written acyclically via the S7 program to an IO-Link device</li> <li>• parameters, measured values and diagnostic data are read from an IO-Link device</li> </ul>

### Input Parameters

Parameters	Data type	Description
REQ	BOOL	Positive edge: Initiate data transfer
	HW_IO	For S7-1200/1500 Hardware ID of the IO-Link communication module
	DWORD	For S7-300/400 Logical address of the IO-Link communication module (module or sub-module)
CAP	DINT (S7-1200/1500) INT (S7-300/400)	Client Access Point (CAP = 0xB400)
RD_WR	BOOL	Read and write access 0: read 1: write
PORT	INT	Port number on which the IO-Link device is operated. Possible values: 0 ... 63 Port 0 IO-Link master module; Port 1 IO-Link device on port 1 etc.
IOL_INDEX	INT	Number of the IO-Link index to be read out or written to
IOL_SUBINDEX	INT	Number of the IO-Link subindex to be read out or written to; 0: entire record 1 ... 255: Parameters from record
LEN	INT	Length of data to be written (net data) Read: 0 ... 232 (not relevant) Write: 1 ... 232

### Output Parameter

Parameters	Data type	Description
DONE_VALID	BOOL	Validity: 0: Data not valid 1: Data valid
BUSY	BOOL	Order in progress: 0: Order completed (valid or error) 1: Order processing in progress
ERROR	BOOL	Error status: 0: No errors 1: Abort with error
STATUS	DWORD	ERROR = 1 -> Function error, parameter "STATUS" and parameter "STATUS error code" ERROR = 0 -> Status of function DW#16#000x0000

Parameters	Data type	Description
		(x: processing step 0 ... 3)
IOL_STATUS	DWORD	ERROR = 1 -> IO-Link error or communication error, error codes"
RD_LEN	INT	Length of data read (net data)

### Input and Output Parameters

Parameters	Data type	Description
RECORD_IOL_DATA	ARRAY [0 ... 231] of BYTE	Source area and destination area for the data to be read and written

### Parameter STATUS

The STATUS consists of 4 bytes:

Byte 3	Byte 2	Byte 1	Byte 0
Manufacturer-specific ID	0x80 Defines the error as a cyclic communication error	<b>STATUS Code</b>	Manufacturer-specific ID

Status code	Name	Description
0xFF000000	TIMEOUT	Internal error in communication with the module
0x00FFFF00	INVALID_HANDLE	
0x00FFFE00	HANDLE_OUT_OF_BUFFERS	
0x00FFFD00	HANDLE_DESTINATION_UNAVAILABLE	
0x00FFFC00	HANDLE_UNKNOWN	
0x00FFFB00	HANDLE_METHOD_INVALID	
0xxx80A0xx	MASTER_READ_ERROR	Error during reading
0xxx80A1xx	MASTER_WRITE_ERROR	Error during writing
0xxx80A2xx	MASTER_MODULE_FAILURE	Failure of the IO-Link master, possibly bus fault
0xxx80A6xx	MASTER_NO_DATA	No data received
0xxx80A7xx	MASTER_BUSY	IO-Link master busy
0xxx80A9xx	MASTER_FEATURE_NOT_SUPPORTED	Function not supported by the IO-Link master.
0xxx80AAxx	MASTER_RESOURCE_UNAVAILABLE	IO-Link masters not available
0xxx80B0xx	ACCESS_WRITE_LENGTH_ERROR	Index invalid, wrong INDEX_CAP used
0xxx80B1xx	ACCESS_WRITE_LENGTH_ERROR	The length of the data to be written cannot be processed by the module, incorrect module may have been addressed
0xxx80B2xx	ACCESS_INVALID_DESTINATION	Wrong slot addressed
0xxx80B03xx	ACCESS_TYPE_CONFLICT	IOL_CALL invalid
0xxx80B5xx	ACCESS_STATE_CONFLICT	Error in IOL_CALL sequence
0xxx80B6xx	ACCESS_DENIED	IO-Link master module denies access
0xxx80C2xx	RESOURCE_BUSY	IO-Link master module busy or waiting for a response from the connected IO-Link device
0xxx80C3xx	RESOURCE_UNAVAILABLE	
0xxx8901xx	INPUT_LEN_TOO_SHORT	The index to be read contains more data than was specified in the input variable "LEN" to be read

## IOL\_STATUS

The IOL\_STATUS consists of 2 bytes of IOL **M** error codes and 2 bytes of IOL error types.

FB IO\_LINK\_DEVICE – Parameter IOL\_STATUS/IOL **M** error codes

Error code	Designation as per spec.	Meaning
IOL M Error Codes (2 bytes)		
0x0000	No error	No error
0x7000	IOL_CALL conflict	Unexpected write request, read request expected
0x7001	Wrong IOL_CALL	Decoding error
0x7002	Port blocked	Port blocked by another task
...	Reserved	-
0x8000	Timeout	Timeout, IOL master or IOL device ports busy
0x8001	Wrong index	Error: IOL index <32767 or >65535 specified
0x8002	Wrong port address	Port address not available
0x8003	Wrong port function	Port function not available
...	Reserved	-

Error code	Designation as per spec.	Meaning
IOL Error Types (2 bytes)		
0x1000	COM_ERR	Communication error Possible cause: The addressed port is parameterized as DI and is not in IO-Link mode
0x1100	I_SERVICE_TIMEOUT	Timeout in communication, device may not respond fast enough
0x5600	M_ISDU_CHECKSUM	Master reports checksum error, access to device not possible
0x5700	M_ISDU_ILLEGAL	Device cannot process request from master
0x8000	APP_DEV	Application error in the device
0x8011	IDX_NOTAVAIL	Index not available
0x8012	SUBIDX_NOTAVAIL	Subindex not available
0x8020	SERV_NOTAVAIL	Service temporarily unavailable
0x8021	SERV_NOTAVAIL_LOCCTRL	Service temporarily unavailable, device busy (e.g. teaching/parameterization of the device active on the device)
0x8022	SERV_NOTAVAIL_DEVCTRL	Service temporarily unavailable, device busy (e.g. teaching/parameterization of the device via DTM/ PLC, etc. active)
0x8030	PAR_VALOUTOFRNG	Parameter value outside valid range
0x8031	PAR_VALGTLIM	Parameter value above upper limit
0x8032	PAR_VALLTLM	Parameter value below lower limit
0x8033	VAL_LENORRRUN	Length of the data to be written does not match the length defined for the parameter
0x8034	VAL_LENUNDRUN	
0x8035	FUNC_NOTAVAIL	Function not available in device
0x8036	FUNC_UNAVAILTEMP	Function temporarily unavailable in device
0x8040	PARA_SETINVALID	Invalid parameter: Parameters may not match other device parameterizations
0x8041	PARA_SETINCONSIST	Parameter inconsistent
0x8082	APP_DEVNOTRDY	Application not ready, device busy
0x8100	UNSPECIFIC	Manufacturer-specific according to device documentation
0x8101 to	VENDOR_SPECIFIC	

Error code	Designation as per spec.	Meaning
0x80FF		

## 8.6 Default Setting

### 8.6.1 Topology

PROFINET offers various functions, diagnostics and maintenance options that are based on the existing topology or use the knowledge about it.

All EP8P001 support the topology setting as well as the automatic topology detection by the engineering tool.

The following shows how to set the topology for IMPACT67. Setting via connected neighboring devices is done via ports **X1 P1** and **X1 P2**, which represent the physical interfaces.

In the **Port interconnection tab | Partner port** a list of the possible ports, devices available in the project is available via the **Partner port** selection item

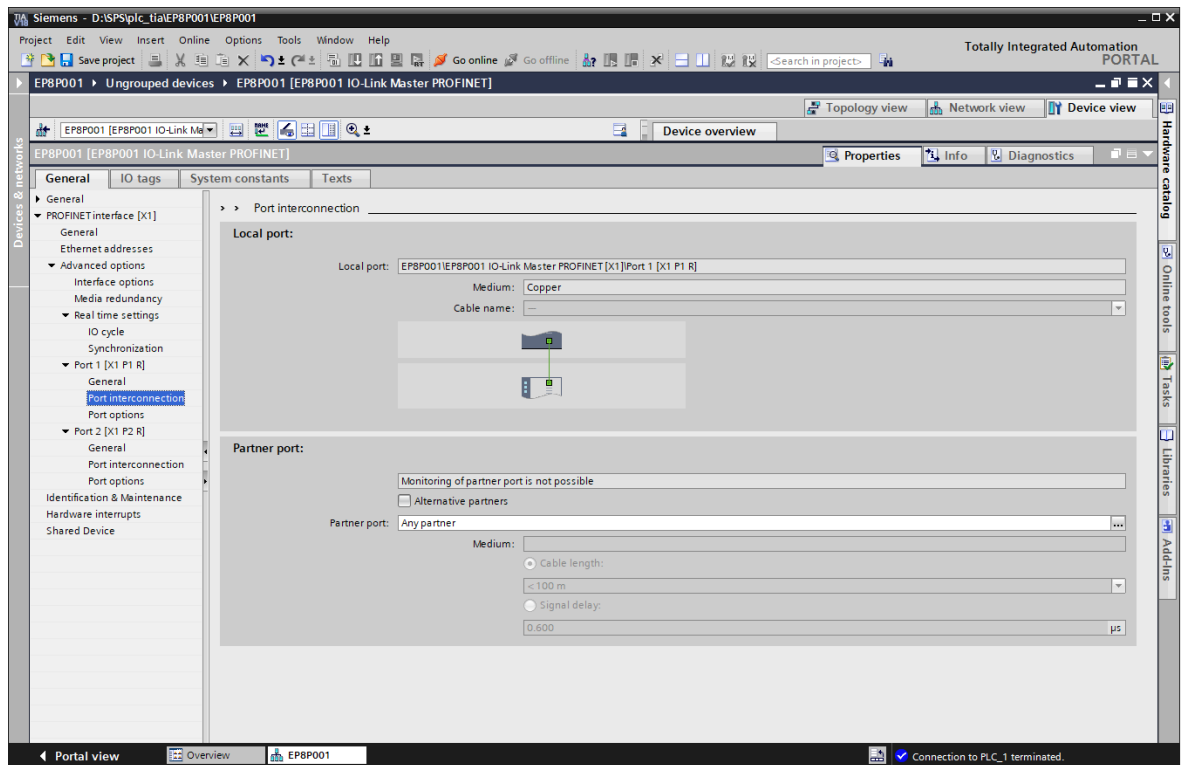

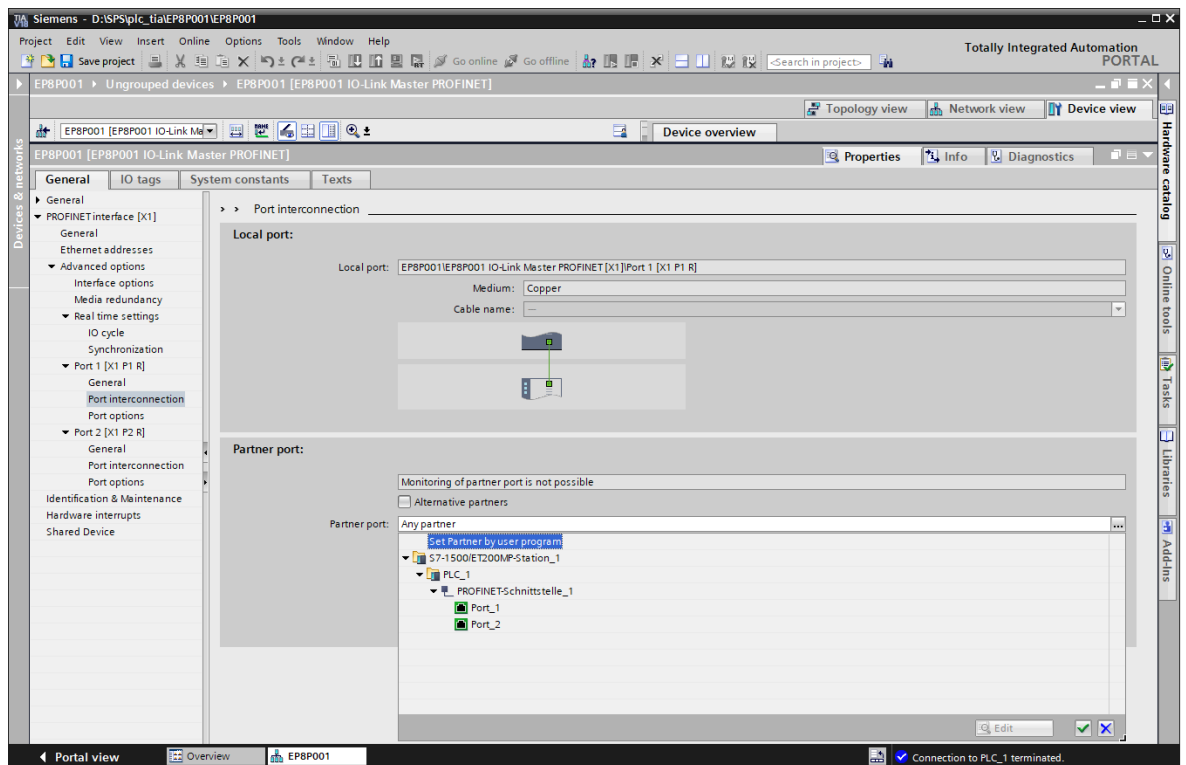

## Identification of the Individual Modules in the Network

PNIO devices are identified via their MAC address and the respective module type.

If you want to commission several modules of the same type, they must be clearly differentiated from each other.

You can use the following path to search for accessible participants online by selecting the “PN/IE\_1” network in the network view | Assign PROFINET device name.

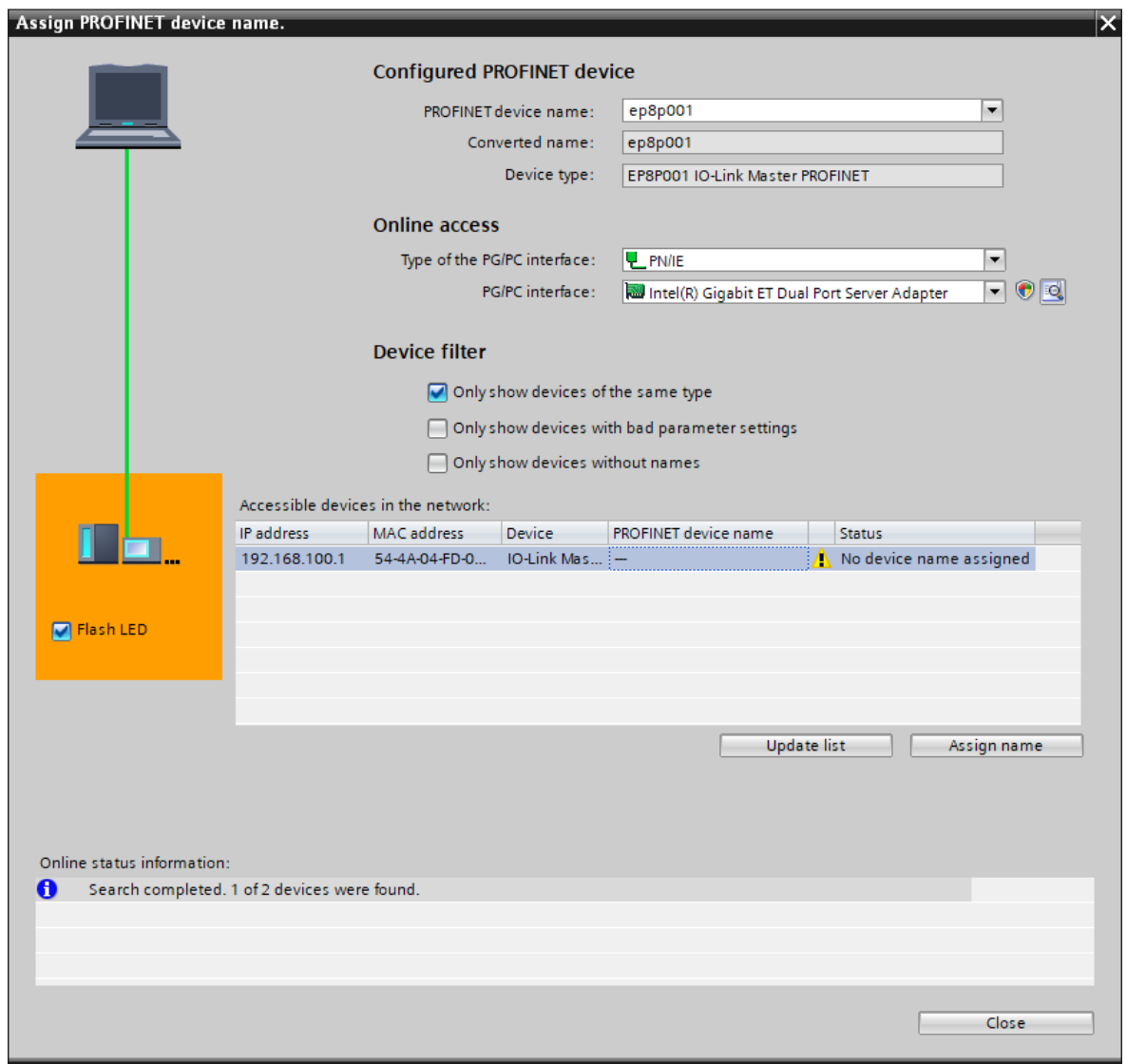

Identification takes place via the flash test. This causes the LEDs of the selected EP8P001 to flash. **See 9.1.8 “Advanced LED display”**

1. Select the available module.
2. Select the Flash LED option.

## 8.6.2 PROFINET Device Name

### Assign PROFINET Device Name

Once you have uniquely identified a module, you can assign a name to it.

The IP address is automatically assigned by the PNIO controller via DCP (Discovery and Configuration Protocol).

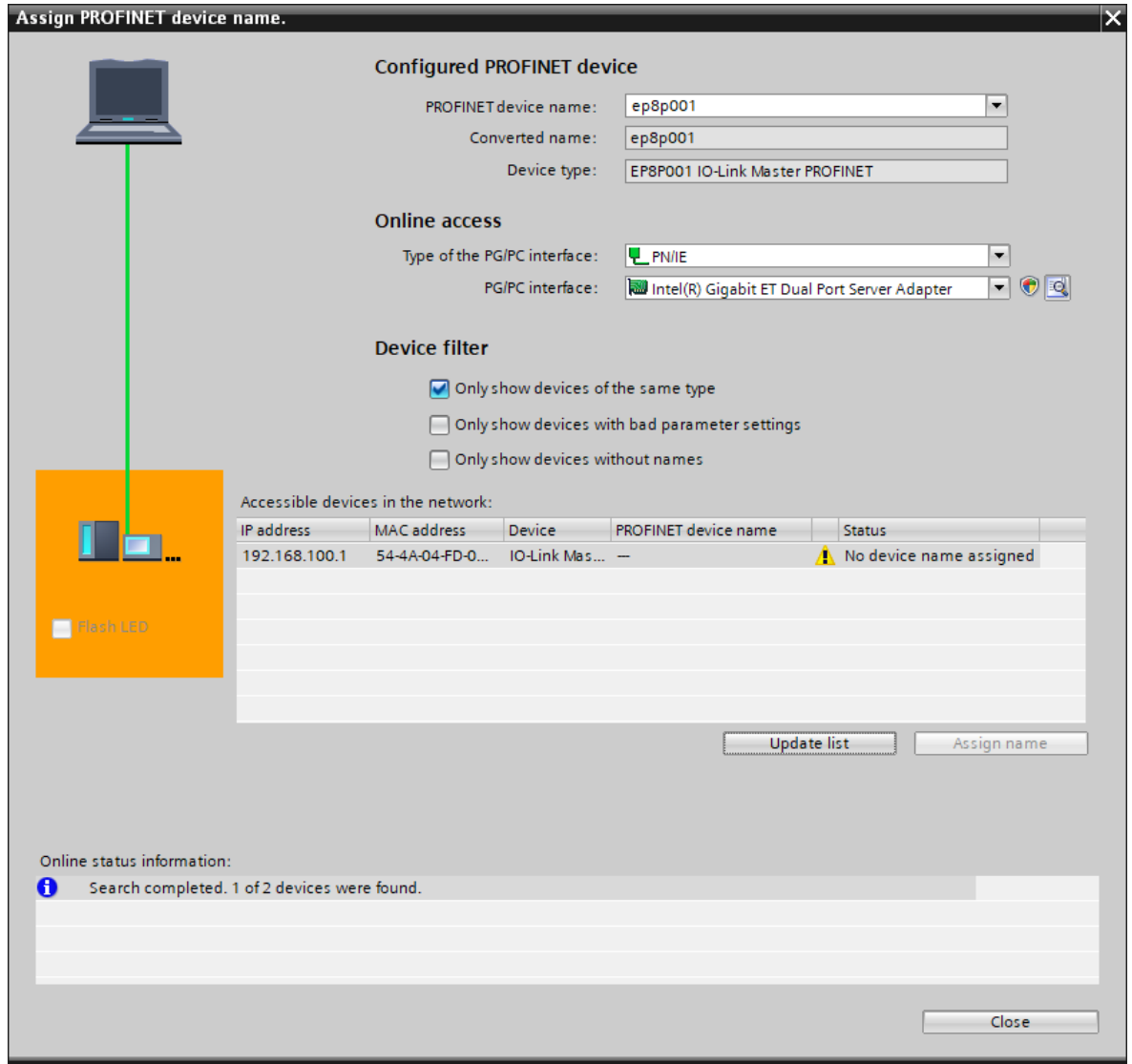

The address and name resolution is only regulated via this name remanently stored in the module.

1. Select a module.
2. Click **Assign name**.

## PROFINET Device Name

**Assign PROFINET device name.**

**Configured PROFINET device**

PROFINET device name: ep8p001  
Converted name: ep8p001  
Device type: EP8P001 IO-Link Master PROFINET

**Online access**

Type of the PG/PC interface: PN/IE  
PG/PC interface: Intel(R) Gigabit ET Dual Port Server Adapter

**Device filter**

- Only show devices of the same type
- Only show devices with bad parameter settings
- Only show devices without names

Accessible devices in the network:

IP address	MAC address	Device	PROFINET device name	Status
192.168.100.1	54-4A-04-FD-0...	IO-Link Mas...	ep8p001	OK

Flash LED

Update list Assign name

Online status information:

- Search completed. 1 of 2 devices were found.
- The PROFINET device name "ep8p001" was successfully assigned to MAC address "54-4A-04-FD-00-15".

Close

The TIA Portal now displays the **EP8P001** module with the newly assigned device name.

## Assigning IP Addresses

You can assign an IP address to the EP8P001 module that is not saved in the module. Enter the desired IP address and the subnet mask to be used.

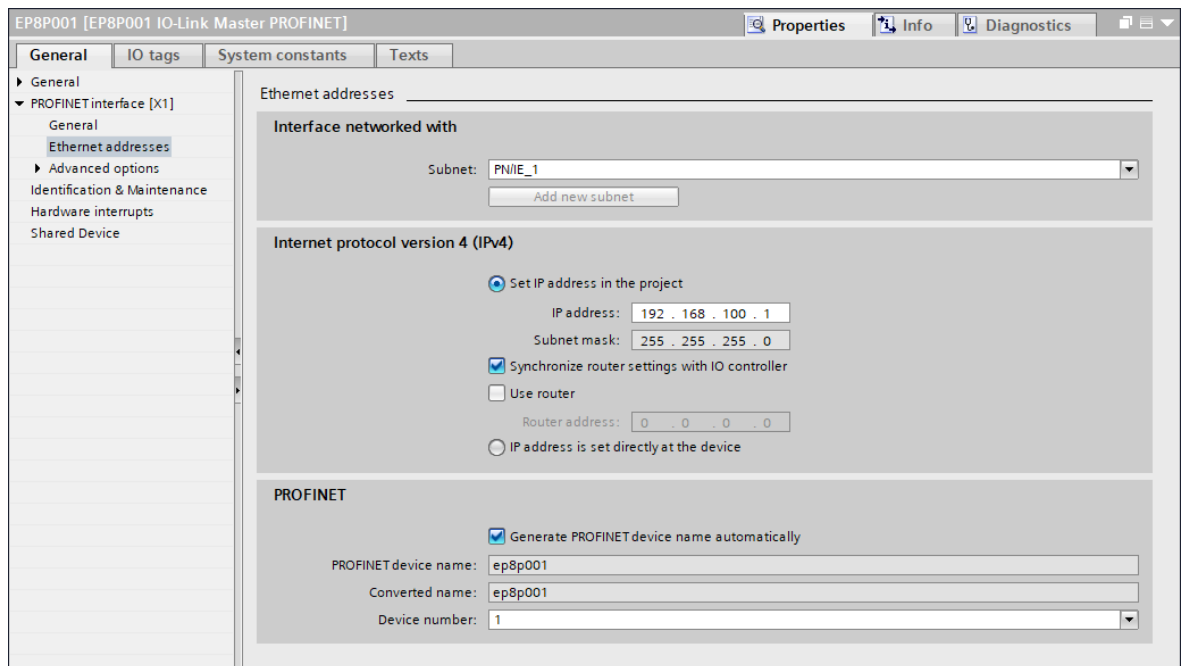

Under **Properties | General**

- Double-click **Ethernet addresses**.

## 8.6.3 Factory settings

### Reset to Default Settings – Keep I&M Data

The Reset to default settings – Keep I&M data function resets the module to default settings, but keeps the saved I&M data.

Complete the following steps:

1. In the TIA Portal, click Connect online.
2. After connecting, highlight the module in question.
3. Open the EP8P001 module in the project navigation. Double-click on Online & Diagnostics.
4. Under the Functions tab, click Reset to default settings to open a window.
5. Enable Keep I&M data selection.
6. Press the Reset button.

The module is reset to default settings.

### Reset to Default Settings – Default Values

Setting	Value
IP address	0.0.0.0
Subnet mask	0.0.0.0
Router address	0.0.0.0
PROFINET device name	Empty

### Reset to Default Settings – I&M Values

I&M values	Value
System designation	Empty
Location ID	Empty
Installation date	Empty
Description	Empty

I&M values	Value
Additional Information	Empty

### Reset to Default Settings – Keep I&M Data

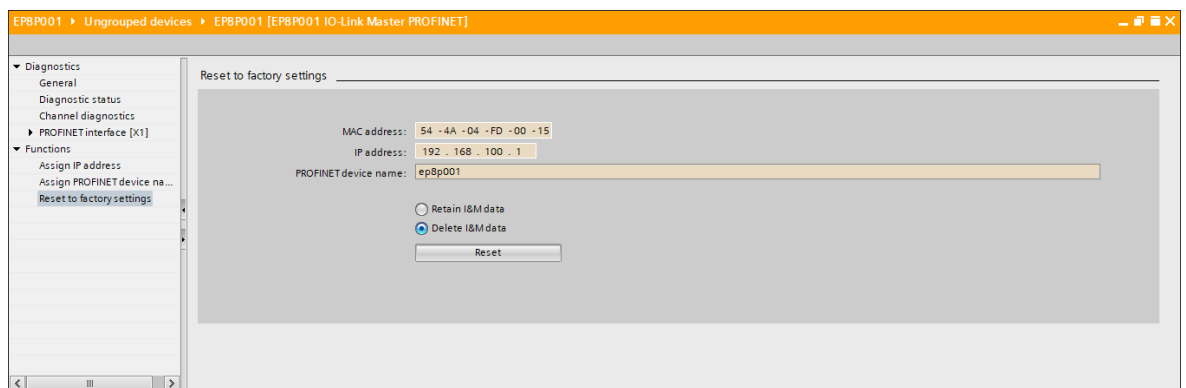
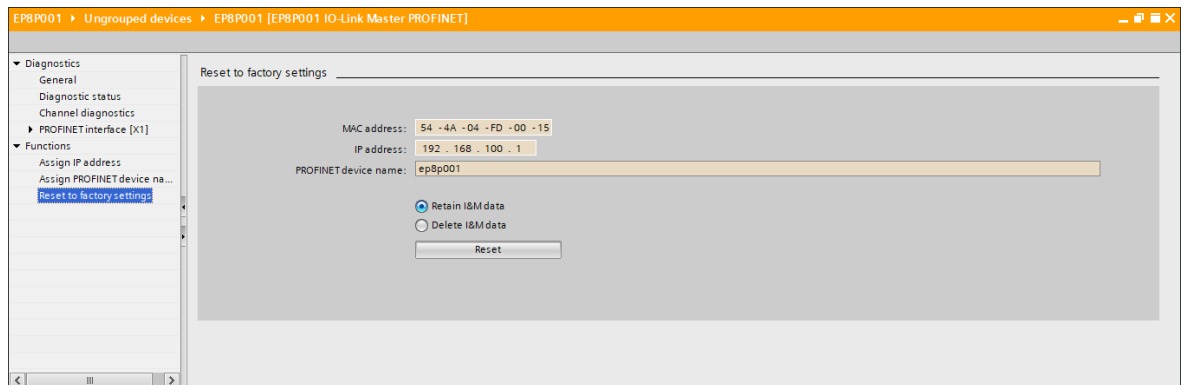

### Reset to Default Settings – Delete I&M Data

The Reset to default settings – Delete I&M data function resets the module to default settings and deletes the saved I&M data.

Complete the following steps:

1. In the TIA Portal, click Connect online.
2. After connecting, highlight the relevant module.
3. Open the EP8P001 module in the project navigation. Double-click on Online & Diagnostics.
4. Under the Functions tab, click Reset to default settings to open a window.
5. Activate the Delete I&M data selection.
6. Press the Reset button.

The module is reset to default settings.

### Reset to Default Settings – Delete I&M Data

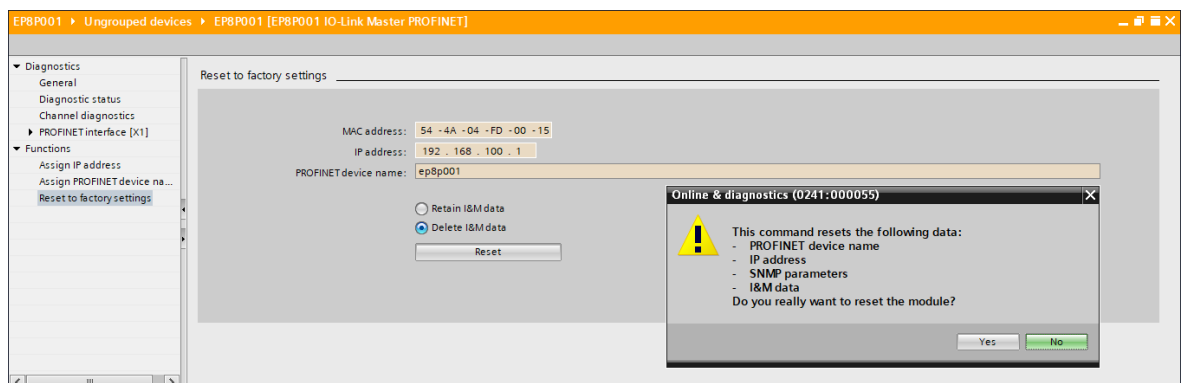

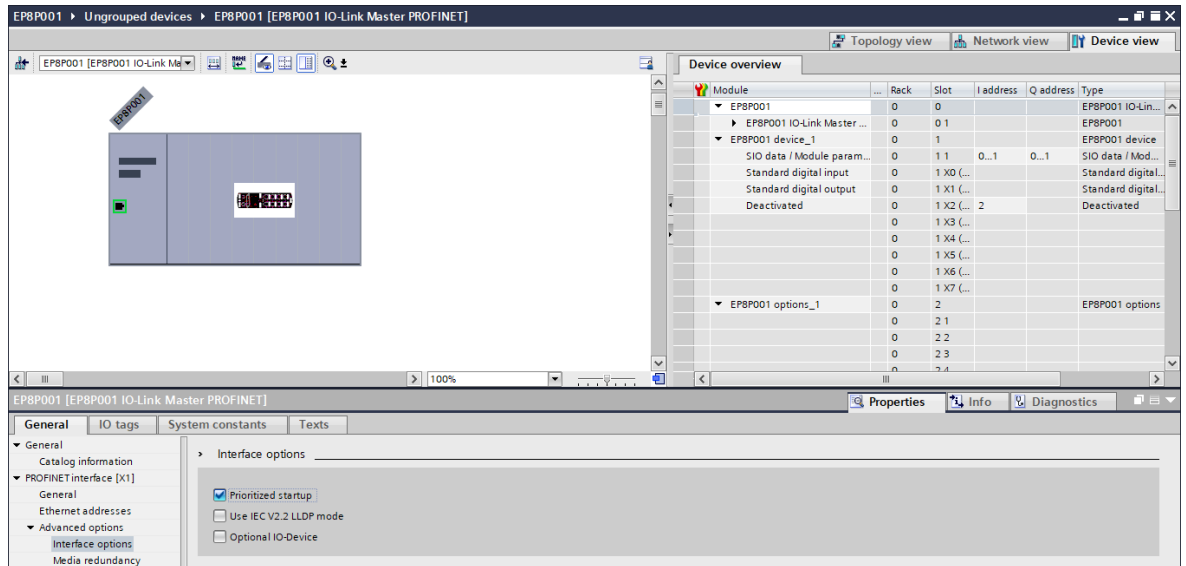

## 8.7 Media Redundancy Protocol (MRP) Configuration

Refer to your engineering software manual for the procedure to configure media redundancy. An example of a configuration using Siemens TIA Portal Engineering Software is described here. Preparatory steps:

1. Create a project in the TIA Portal.
2. Add a controller with two ports or an additional PROFINET managed switch.
3. Add the EP8P001 device.
4. Assign the EP8P001 device to the controller (see “Set up MRP Manager”).

### Setting Up MRP Manager

For a ring configuration, 2 ports of a PROFINET managed switch or an S7 CPU must be set up as ring manager and all other participants as clients.

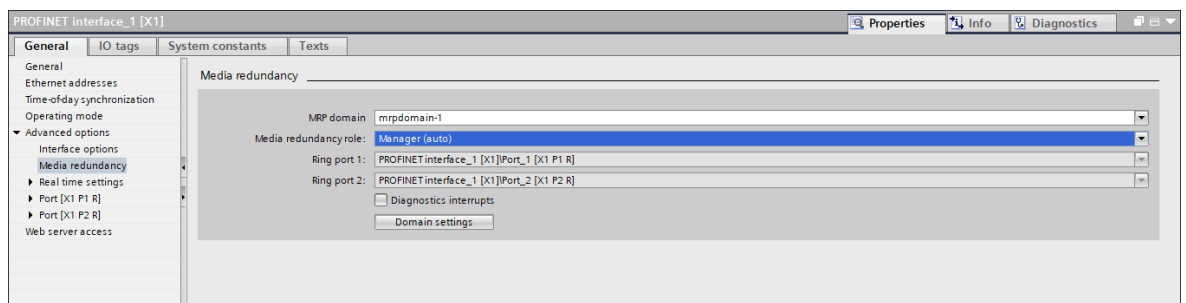

1. Select the PROFINET Managed Switch.
2. To the PROFINET interface menu item | Advanced options | Navigate media redundancy.
3. Set Manager (auto) under “Media redundancy role”.
4. Activate the “Diagnostic alarms” selection.

## Setting Up MRP Client

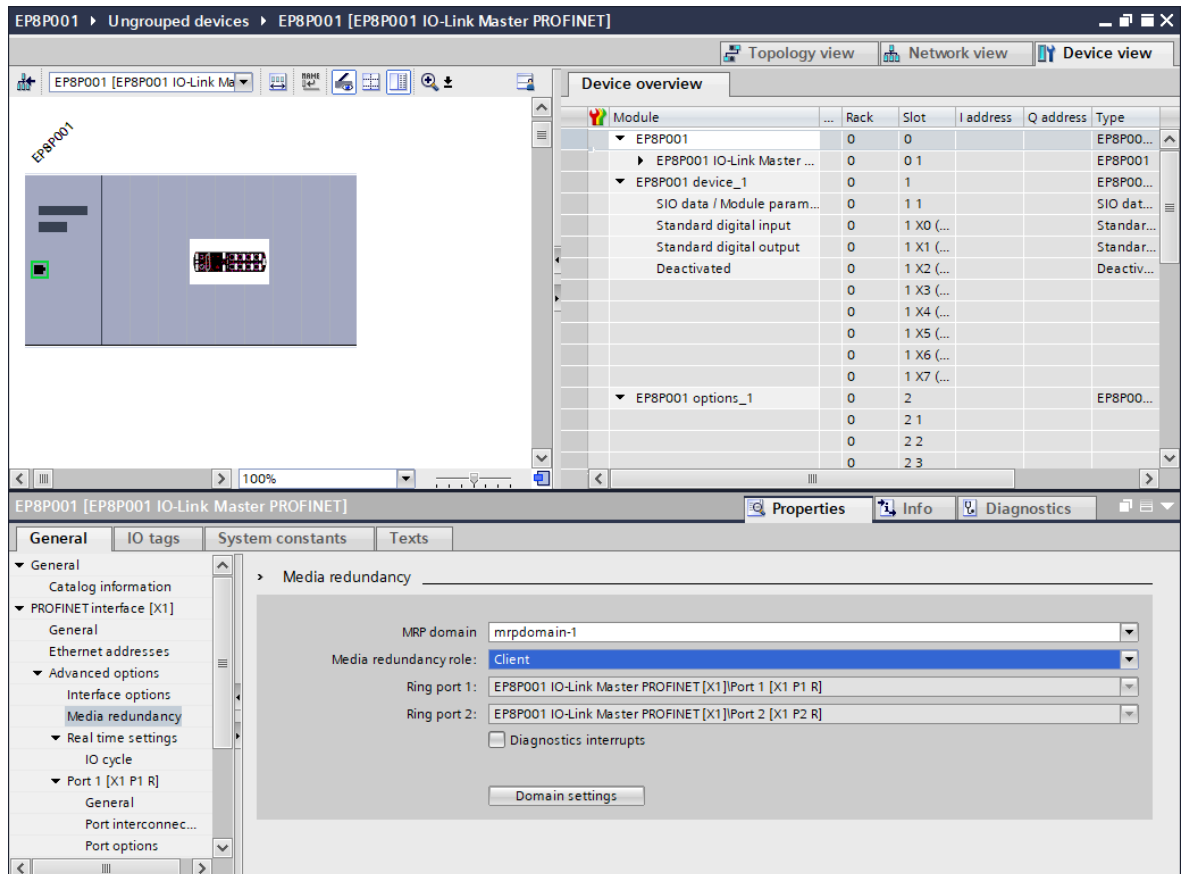

1. Select the EP8P001 module.
2. To the PROFINET interface menu item | Advanced options | Navigate media redundancy.
3. Set client for “Media redundancy role”.
4. Enable diagnostic alarms.
5. Don't forget: The EP8P001 module must be in the same MRP domain

## Set Up MRP Cycle Times

If the media redundancy has been set, the IO cycle times must be parameterized for each module.

Depending on the PLC, RT requirements and expansion of the system, the IO cycle times and factors must be set in the following window.

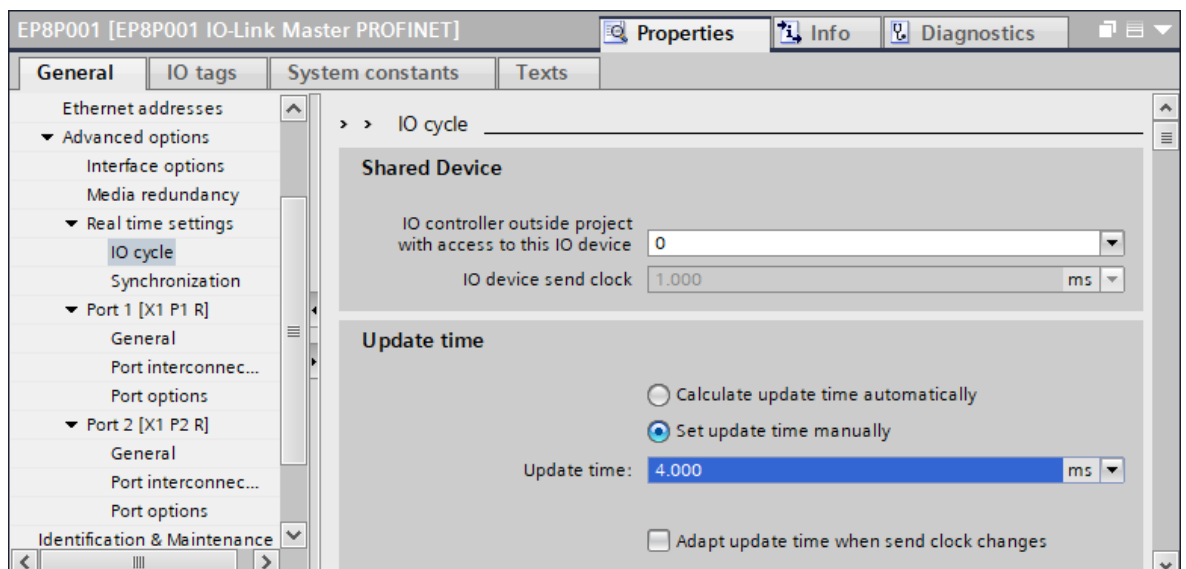

1. To the PROFINET interface menu item | Advanced options | Real time settings | Navigate IO cycle.
2. Set the values: Update time and accepted update cycles without IO data

## Set Up MRP Domain

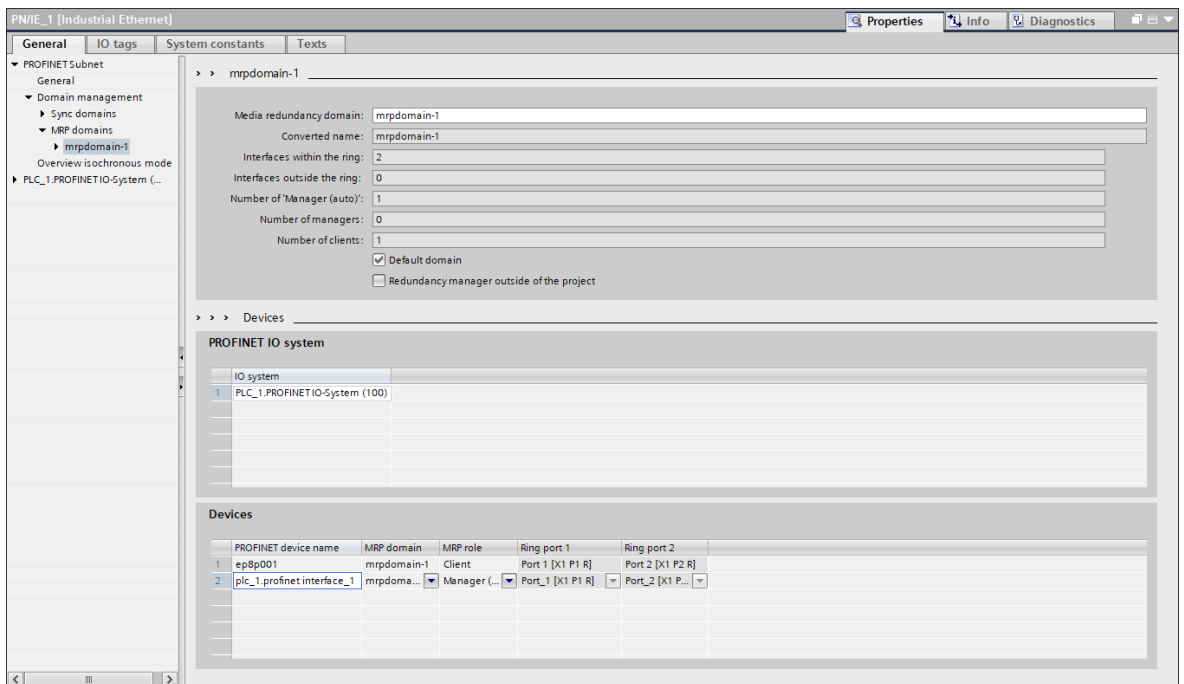

1. To the **Domain management** menu item | **MRP domains** | **Navigate to mrpdomain-1** to get an overview of the ring participants.
2. Assign the **PROFINET managed switch** to the IO controller.
3. Save the created project.
4. Click on the **PNIE subnet**. The **PLC\_1.PROFINET IO system (100)** bus is displayed.
5. Assign the EP8P001 module to the IO controller.

**Devices** shows all participants in the ring configuration.

## 8.8 Isochronous Real Time (IRT) Configuration

### IRT

Refer to your engineering software manual for the procedure to configure the IRT operation.

An example of a configuration using Siemens TIA Portal Engineering Software is described here. As a prerequisite for this type of communication, special hardware components are required that are real-time-capable (IRT).



### INFORMATION

The device is not an active participant in IRT data exchange. It supports loss-free forwarding of IRT telegrams for synchronized fieldbus devices in the same Ethernet subnet.

Preparatory steps:

- Create a project in the TIA Portal.
- Add an IRT-capable controller.
- Add the device.
- Connect the PROFINET interfaces.



## INFORMATION

Make sure that no media redundancy is set (see section “Media Redundancy Protocol (MRP) Configuration [▶ 71]”).

## IRT Communication: Set Up Sync Master



## INFORMATION

This procedure describes the project planning of non-clock-synchronized IRT communication. Refer to the system manual of your engineering software to set up clock synchronized IRT communication.

The screenshot displays the SIMATIC Manager interface for a PLC\_1 [CPU 1511-1 PN]. The main window shows a rack diagram with slots 0-15. The 'Device overview' table on the right lists the modules installed in each slot:

Module	Rack	Slot
	0	100
	0	0
PLC_1	0	1
PROFINET interface_1	0	1 X1
	0	2
	0	3
	0	4
	0	5
	0	6
	0	7
	0	8
	0	9
	0	10
	0	11
	0	12
	0	13
	0	14
	0	15

The 'PROFINET interface\_1 [X1]' properties window is open, showing the 'Synchronization' settings:

- Sync domain: Sync-Domain\_1
- Synchronization role: Sync master
- RT class: RT,IRT

1. Double-click on the PLC\_1 controller.
2. To the Advanced options menu item | Real time setting | Navigate synchronization.
3. Set Sync Master as “Synchronization role”.

## IRT Communication: Set Up Sync Master



### INFORMATION

This procedure describes the project planning of non-clock-synchronized IRT communication. Refer to the system manual of your engineering software to set up clock synchronized IRT communication.

Module	Rack	Slot	I address	Q address	Type
EP8P001	0	0			EP8P001 IO-Li...
EP8P001 IO-Link Master ...	0	0 1			EP8P001
EP8P001 device_1	0	1	0...1	0...1	EP8P001 device
SIO data / Module param...	0	1 1	0...1	0...1	SIO data / Mod...
	0	1 X0 (...)			
	0	1 X1 (...)			
	0	1 X2 (...)			
	0	1 X3 (...)			
	0	1 X4 (...)			
	0	1 X5 (...)			
	0	1 X6 (...)			
	0	1 X7 (...)			
EP8P001 options_1	0	2			EP8P001 optio...
	0	2 1			
	0	2 2			
	0	2 3			
	0	2 4			
	0	2 5			

**Synchronization**

Sync domain: Sync-Domain\_1 [Domain settings]

RT class:  RT  IRT

Synchronization role: Unsynchronized

## 8.9 Simple Network Management Protocol (SNMP)

### Send SNMP Request

Query

All wenglor PROFINET devices can send an SNMP message on request:

- SNMPv2-MIB:sysDescr.0 Object (1.3.6.1.2.1.1.1.0).

Response

The response from the device has the following structure:

- wenglor sensoric GmbH, EP8P001, art. no., HW status, SW status, MAC address.

## 8.10 Industrial Internet of Things (IIoT)

### 8.10.1 JSON

#### General JSON Settings

No.	REST API URL	Description	Supports
1	GET /iolink/v1/gateway/identification	Identification of the gateway	OK
2	GET /iolink/v1/gateway/capabilities	Capabilities of the gateway	OK
3	GET /iolink/v1/gateway/configuration	Read network configuration of the gateway	OK
4	POST /iolink/v1/gateway/configuration	Write network configuration of the gateway	OK
5	POST /iolink/v1/gateway/reset	Reset the gateway including all masters	-
6	POST /iolink/v1/gateway/reboot	Reboot the gateway including all masters	-
7	GET /iolink/v1/gateway/events	Event log containing all events from gateway, masters, ports and devices	OK
8	GET /iolink/v1/masters	Get all available master number keys and identification information	OK
9	GET /iolink/v1/masters/\$MASTER_NUMBER/capabilities	Capabilities of the master	OK
10	GET /iolink/v1/masters/\$MASTER_NUMBER/identification	Read identification of the master	OK
11	POST /iolink/v1/masters/\$MASTER_NUMBER/identification	Write identification of the master	OK
12	GET /iolink/v1/masters/\$MASTER_NUMBER/ports	Get all available port number keys	OK
13	GET /iolink/v1/masters/\$MASTER_NUMBER/ports/\$PORT_NUMBER/capabilities	Read capability information of the specified port	OK
14	GET /iolink/v1/masters/\$MASTER_NUMBER/ports/\$PORT_NUMBER/status	Read status of the master	OK
15	GET /iolink/v1/masters/\$MASTER_NUMBER/ports/\$PORT_NUMBER/configuration	Read configuration of the specified port	OK
16	POST /iolink/v1/masters/\$MASTER_NUMBER/ports/\$PORT_NUMBER/configuration	Write configuration of the specified port	OK
17	GET /iolink/v1/masters/\$MASTER_NUMBER/ports/\$PORT_NUMBER/datastorage	Read data storage content of the specified port	OK
18	POST /iolink/v1/masters/\$MASTER_NUMBER/ports/\$PORT_NUMBER/datastorage	Write data storage content of the specified port	OK
19	GET /iolink/v1/devices	Address all devices of all masters	OK
20	GET /iolink/v1/devices/{deviceAlias}/capabilities	Read capability information of the specified device	OK
21	GET /iolink/v1/devices/{deviceAlias}/identification	Read identification information of the specified device	OK
22	POST /iolink/v1/devices/{deviceAlias}/identification	Write identification information of the specified device	-
23	GET /iolink/v1/devices/{deviceAlias}/processdata/value?format=byteArray	Read process data value from the specified device	OK

No.	REST API URL	Description	Supports
24	GET /iolink/v1/devices/{deviceAlias}/processdata/getdata/value?format=byteArray	Read process data input value from the specified device	OK
25	GET /iolink/v1/devices/{deviceAlias}/processdata/setdata/value?format=byteArray	Read process data output value from the specified device	OK
26	POST /iolink/v1/devices/{deviceAlias}/processdata/value	Write the process data output value to the specified device	OK
27	GET /iolink/v1/devices/{deviceAlias}/parameters/{index}/value/?format=byteArray	Read a specific parameter value and its sub-parameter values (if the parameter has complex type) with the given index of the device	OK
28	GET /iolink/v1/devices/{deviceAlias}/parameters/{index}/subindices/{subindex}/value/?format=byteArray	Read the value of a specific sub-parameter with the given index and subindex	OK
29	GET /iolink/v1/devices/{deviceAlias}/parameters/{parameterName}/value/?format=byteArray	Read a specific parameter value with the given name	-
30	POST /iolink/v1/devices/{deviceAlias}/parameters/{index}/value	Write the parameter with the given index to the device	OK
31	POST /iolink/v1/devices/{deviceAlias}/parameters/{parameterName}/value	Write the parameter with the given name to the device	-
32	POST /iolink/v1/devices/{deviceAlias}/parameters/{index}/subindices/{subindex}/value	Write the sub-parameter with the given index and subindex to the device	OK
33	POST /iolink/v1/devices/{deviceAlias}/parameters/{parameterName}/subindices/{subParameterName}/value	Write the sub-parameter with the given parameter name and sub-parameter name to the device	OK
34	POST /iolink/v1/devices/{deviceAlias}/blockparametrization/?format=byteArray	Read or write one or more parameters as a block	OK
35	GET /iolink/v1/devices/{deviceAlias}/events	Read event log from the specified device	OK
36	GET /iolink/v1/mqtt/configuration	Read configuration of MQTT clients	OK
37	POST /iolink/v1/mqtt/configuration	Write configuration of MQTT clients	-
38	GET /iolink/v1/mqtt/topics	Read list of MQTT topics	-
39	POST /iolink/v1/mqtt/topics	Write list of MQTT topics	-
40	DELETE /iolink/v1/mqtt/topics/{topicID}	Delete a specific MQTT topic	-
41	GET /iolink/v1/mqtt/topics/{topicID}	Read a specific MQTT topic	-
42	GET /iolink/v1/mqtt/connectionstatus	Read connection status	OK

## Vendor-Specific JSON Settings

No.	REST API URL	Description	Supports
43	GET /iolink/v1/vendor/masters/\$MASTER_NUMBER/diagnostics/configuration	Diagnostic configuration of the master	OK
44	GET /iolink/v1/vendor/masters/\$MASTER_NUMBER/diagnostics/value	Diagnostic values of the master	OK
45	GET /iolink/v1/vendor/masters/\$MASTER_NUMBER/ports/\$PORT_NUMBER/statistics/current	Current statistic values of the specified port of the master	OK

No.	REST API URL	Description	Sup-ports
46	GET /iolink/v1/vendor/masters/ \$MASTER_NUMBER/ports/ \$PORT_NUMBER/statistics/voltage	Voltage statistic values of the specified port of the master	OK
47	GET /iolink/v1/vendor/masters/ \$MASTER_NUMBER/ports/ \$PORT_NUMBER/statistics/temperature	Temperature statistic values of the specified port of the master	OK
48	GET /iolink/v1/vendor/masters/1/ports/ 1/statistics/stack	IO-Link stack statistic values of the specified port of the master	-
49	GET /iolink/v1/vendor/masters/ \$MASTER_NUMBER/ports/ \$PORT_NUMBER/diagnostics/configuration	Diagnostic configuration of the specified port of the master	OK
50	GET /iolink/v1/vendor/masters/ \$MASTER_NUMBER/ports/ \$PORT_NUMBER/ diagnostics/current	Diagnostic current value of the specified port of the master	OK
51	GET /iolink/v1/vendor/masters/ \$MASTER_NUMBER/ports/ \$PORT_NUMBER/diagnostics/voltage	Diagnostic voltage value of the specified port of the master	OK
52	GET /iolink/v1/vendor/masters/ \$MASTER_NUMBER/ports/ \$PORT_NUMBER/diagnostics/temperature	Diagnostic temperature value of the specified port of the master	OK

## 8.10.2 MQTT



### INFORMATION

When activating MQTT, JSON must be activated.

### MQTT Settings

No.	REST API URL	Description
1	\$MQTT_CLIENT_HEAD_TOPIC/iolink/v1/gateway/identification	Identification of the gateway
2	\$MQTT_CLIENT_HEAD_TOPIC/iolink/v1/gateway/capabilities	Capabilities of the gateway
3	\$MQTT_CLIENT_HEAD_TOPIC/iolink/v1/gateway/configuration	Network configuration of the gateway
4	\$MQTT_CLIENT_HEAD_TOPIC/iolink/v1/masters	Get all available master number keys and identification information
5	\$MQTT_CLIENT_HEAD_TOPIC/iolink/v1/vendor/masters/ \$MASTER_NUMBER/diagnostics/value	Diagnostic values of the master
6	\$MQTT_CLIENT_HEAD_TOPIC/iolink/v1/vendor/masters/ \$MASTER_NUMBER/diagnostics/configuration	Diagnostic configuration of the master
7	\$MQTT_CLIENT_HEAD_TOPIC/iolink/v1/masters/ \$MASTER_NUMBER/capabilities	Capabilities of the master
8	\$MQTT_CLIENT_HEAD_TOPIC/iolink/v1/masters/ \$MASTER_NUMBER/identification	Identification of the master

No.	REST API URL	Description
9	\$MQTT_CLIENT_HEAD_TOPIC/iolink/v1/masters/ \$MASTER_NUMBER/ports	Get all available port number keys
10	\$MQTT_CLIENT_HEAD_TOPIC/iolink/v1/masters/ \$MASTER_NUMBER/ports/\$PORT_NUMBER/capabilities	Read capability information of the specified port
11	\$MQTT_CLIENT_HEAD_TOPIC/iolink/v1/masters/ \$MASTER_NUMBER/ports/\$PORT_NUMBER/status	Read actual status of the specified port
12	\$MQTT_CLIENT_HEAD_TOPIC/iolink/v1/masters/ \$MASTER_NUMBER/ports/\$PORT_NUMBER/configuration	Read/Write configuration of the specified port
13	\$MQTT_CLIENT_HEAD_TOPIC/iolink/v1/vendor/masters/ \$MASTER_NUMBER/ports/\$PORT_NUMBER/diagnostics/Configuration	Diagnostic configuration of the specified port of the master
14	\$MQTT_CLIENT_HEAD_TOPIC/iolink/v1/vendor/masters/ \$MASTER_NUMBER/ports/\$PORT_NUMBER/diagnostics/current	Diagnostic current value of the specified port of the master
15	\$MQTT_CLIENT_HEAD_TOPIC/iolink/v1/vendor/masters/ \$MASTER_NUMBER/ports/\$PORT_NUMBER/diagnostics/voltage	Diagnostic voltage value of the specified port of the master
16	\$MQTT_CLIENT_HEAD_TOPIC/iolink/v1/vendor/masters/ \$MASTER_NUMBER/ports/\$PORT_NUMBER/diagnostics/temperature	Diagnostic temperature value of the specified port of the master
17	\$MQTT_CLIENT_HEAD_TOPIC/iolink/v1/vendor/masters/ \$MASTER_NUMBER/ports/\$PORT_NUMBER/statistics/current	Current statistic values of the specified port of the master
18	\$MQTT_CLIENT_HEAD_TOPIC/iolink/v1/vendor/masters/ \$MASTER_NUMBER/ports/\$PORT_NUMBER/statistics/voltage	Voltage statistic values of the specified port of the master
19	\$MQTT_CLIENT_HEAD_TOPIC/iolink/v1/vendor/masters/ \$MASTER_NUMBER/ports/\$PORT_NUMBER/statistics/temperature	Temperature statistic values of the specified port of the master
20	\$MQTT_CLIENT_HEAD_TOPIC/iolink/v1/devices/ \$DEVICE_ALIAS/processdata/value	Read/Write process data value from/to the specified device
21	\$MQTT_CLIENT_HEAD_TOPIC/iolink/v1/devices/ \$DEVICE_ALIAS/processdata/getdata/value	Read process data input value from the specified device
22	\$MQTT_CLIENT_HEAD_TOPIC/iolink/v1/devices/ \$DEVICE_ALIAS/processdata/setdata/value	Temperature statistic values of the specified port of the master
23	\$MQTT_CLIENT_HEAD_TOPIC/iolink/v1/devices/ \$DEVICE_ALIAS/events	Read/Write process data value from/to the specified device
24	\$MQTT_CLIENT_HEAD_TOPIC/Asset	Read process data output value from the specified device
25	\$MQTT_CLIENT_HEAD_TOPIC/iolink/v1/devices/ \$DEVICE_ALIAS/events	Read event log from the specified device

## 8.10.3 OPC UA

The devices mentioned in the screenshots serve as examples.

The device has an OPC-UA server. An OPC UA client can connect to the device and access the following parameters:

- Device identification,
- Configuration parameters,
- Process data,
- Measured values,
- Diagnostics Information,
- Statistical information, etc.

The OPC UA client connects using the following URL:

**opc.tcp://IP address:4840**



### INFORMATION

For **IP address**, the IP address of the device is used.

The client can access device parameters anonymously (read only) or with username/password (read and write). The user name and password are set with the web server.

The following figure shows a section of the device's information model.

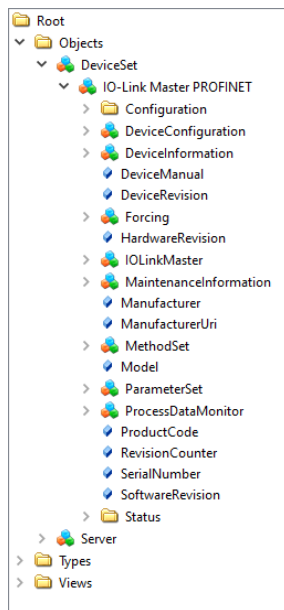

The following figure shows a section of the information model of an IO-Link port.

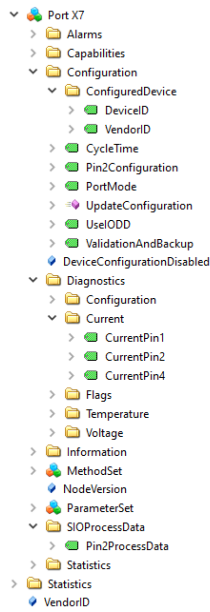

### 8.10.3.1 Authenticate

#### User Login

For OPC UA, the same users and passwords apply as documented in the web server description 10 “Web server”

A connection to the OPC UA server is started with the user “guest”, with which read access to the OPC UA objects is possible.

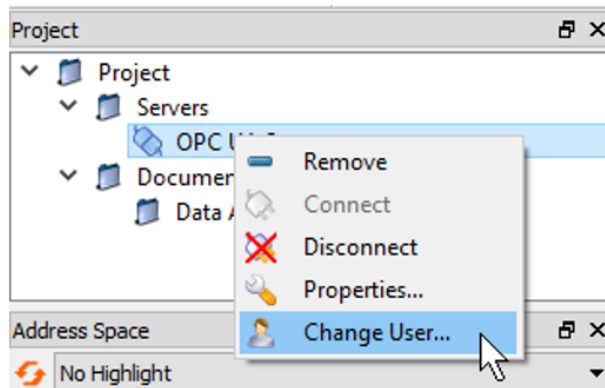

The user must be switched over for further actions.

- Username <admin>
- Password <private>

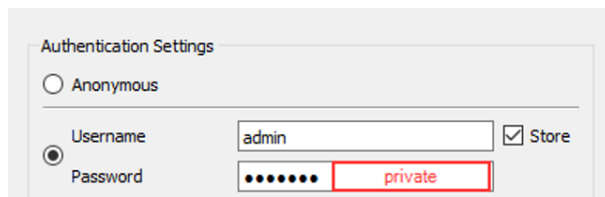

#### Forcing

Digital outputs can be switched manually (forcing) via OPC UA.

##### Step 1

Use the GetForcingID method to generate an ID from the device.

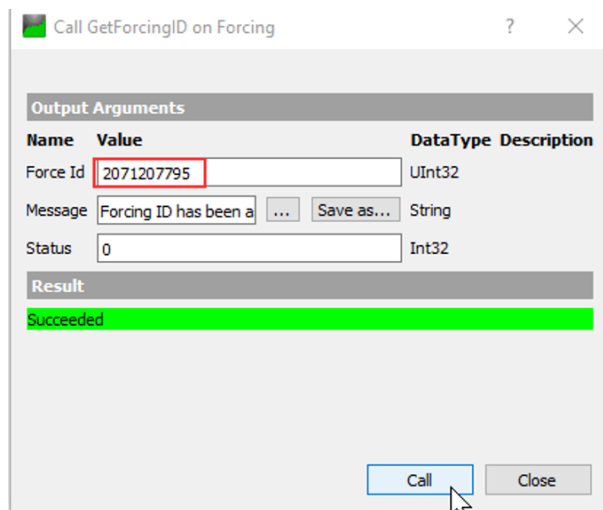
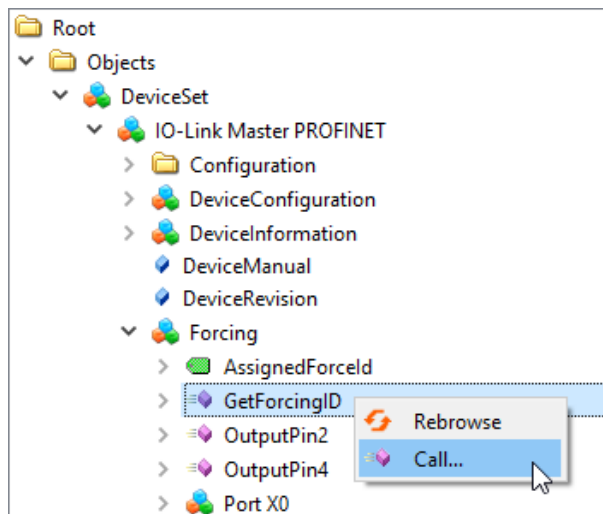

## INFORMATION

The ForcingID is only valid for 10 seconds. The validity is extended to 10 seconds each time a forcing function is called up.

## Step 2

Set digital outputs using the OutputPin2 or OutputPin4 methods.

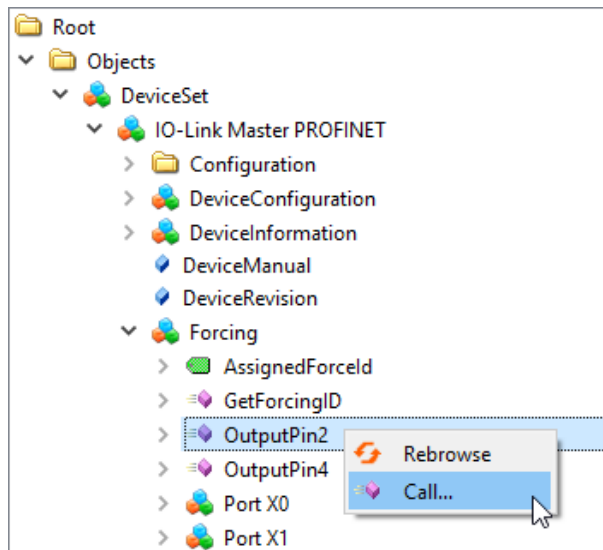

The method expects the received forcing ID, a bit mask and data to be written to be entered as parameters.

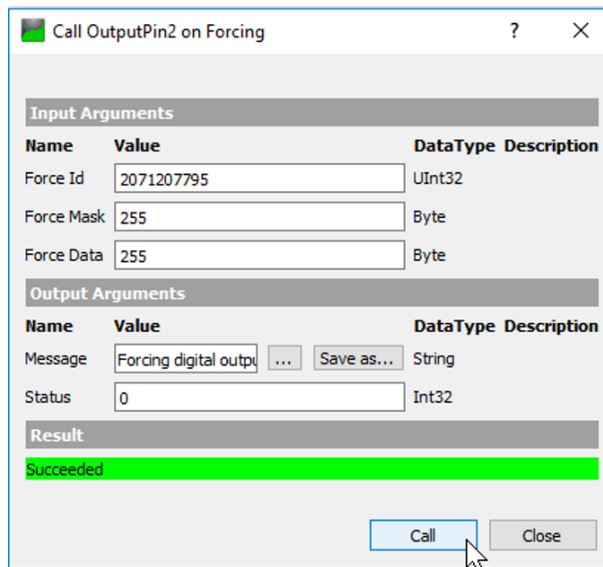

### 8.10.3.2 Device Identification

The device provides nodes for device identification. For example, the OPC UA client can read the version of the device firmware used in the **SoftwareRevision** node.

Node name	Node class	Access	Description
Manufacturer	Variable	Read	Device manufacturer
ManufacturerUri	Variable	Read	Device manufacturer URL
Model	Variable	Read	Model designation of the device
ProductCode	Variable	Read	Product code of the device
RevisionCounter	Variable	Read	Device hardware revision
SerialNumber	Variable	Read	Serial number of device
SoftwareRevision	Variable	Read	Device firmware revision/version

#	Server	Node Id	Display Name	Value	Datatype	Source Timestamp	Server Timestamp	Statuscode
1	OPC UA ...	NS6 Numeric 161	Manufacturer	"en", "wenglor ...	LocalizedText	06:27:09.000	06:27:09.000	Good
2	OPC UA ...	NS6 Numeric 166	ManufacturerUri	www.wenglor.c...	String	06:27:16.000	06:27:16.000	Good
3	OPC UA ...	NS6 Numeric 162	Model	"en", "IO-Link ...	LocalizedText	06:27:38.000	06:27:38.000	Good
4	OPC UA ...	NS6 Numeric 167	ProductCode	EP8P001	String	06:27:49.000	06:27:49.000	Good
5	OPC UA ...	NS6 Numeric 163	RevisionCounter	1	Int32	06:27:51.000	06:27:51.000	Good

### 8.10.3.3 Configuration Parameters

The OPC UA server provides nodes with configuration parameters of the device. For example, the OPC UA client can read the upper limit for the temperature in the **OverTemperature** node.

#### Device-Related Configuration Parameters

Node name	Node class	Access	Default	Description
CurrentHysteresis	Variable	Read	10 mA	Current hysteresis, unit: mA If the current exceeds the limit value, the current must first fall below the limit value again by the hysteresis value in order to cancel the diagnostics.
OverTemperature	Variable	Read	70 °C	Upper limit for the temperature of a port, unit: 0.1 °C
OverVoltageL	Variable	Read	30 V	Upper limit value for the voltage in supply line 1, pins can be monitored with the function L+, DI, DO, DIO, IO-Link, unit: mV
OverVoltageL2	Variable	Read	30 V	Upper limit for the voltage in supply line 2, unit: mV
TemperatureHysteresis	Variable	Read	2 °C	Temperature hysteresis, unit: 0.1 °C If the temperature exceeds the limit value, the temperature must first fall below the limit value by the hysteresis value in order to cancel the diagnostics.
UnderTemperature	Variable	Read	-25 °C	Lower limit for the temperature of a port, unit: 0.1 °C
UnderVoltage L	Variable	Read	18 V	Lower limit value for the voltage in supply line 1, pins can be monitored with the function L+, DI, DO, DIO, IO-Link, unit: mV
UnderVoltage L2	Variable	Read	18 V	Lower limit for the voltage in supply line 2, unit: mV
Voltage Hysteresis	Variable	Read	300 mV	Voltage hysteresis, unit: mV If the voltage exceeds the limit value, the voltage must first drop back below the limit value by the hysteresis value in order to cancel the diagnostics.

#	Server	Node Id	Display Name	Value	Datatype	Source Timestamp	Server Timestamp	Statuscode
1	OPC UA ...	NS6(Numeric...	CurrentHysteresis	10	UInt16	06:29:43.000	06:29:43.000	Good
2	OPC UA ...	NS6(Numeric...	OverTemperature	70	Float	06:29:48.000	06:29:48.000	Good
3	OPC UA ...	NS6(Numeric...	OverVoltageL	30000	Int32	06:29:51.000	06:29:51.000	Good
4	OPC UA ...	NS6(Numeric...	OverVoltageL2	30000	Int32	06:29:54.000	06:29:54.000	Good
5	OPC UA ...	NS6(Numeric...	TemperatureHy...	2	Float	06:29:56.000	06:29:56.000	Good
6	OPC UA ...	NS6(Numeric...	UnderTemperat...	-40	Float	06:29:57.000	06:29:57.000	Good
7	OPC UA ...	NS6(Numeric...	UnderVoltageL	17000	Int32	06:29:59.000	06:29:59.000	Good
8	OPC UA ...	NS6(Numeric...	UnderVoltageL2	17000	Int32	06:30:00.000	06:30:00.000	Good
9	OPC UA ...	NS6(Numeric...	VoltageHysteresis	300	UInt16	06:30:01.000	06:30:01.000	Good

## Port-Related Configuration Parameters

Node name	Node class	Access	Default	Description
OverCurrentPin1, OverCurrentPin2, OverCurrentPin4	Variable	Read	0	Warning level for upper current limit at pin 1, pin 2 or pin 4, unit: 1 mA 0: Monitoring not activated
UnderCurrentPin1, UnderCurrentPin2, UnderCurrentPin4	Variable	Read	0	Warning level for lower current limit at pin 1, pin 2 or pin 4, unit: 1 mA 0: Monitoring not activated

The screenshot shows the 'Address Space' tree on the left and the 'Data Access View' table on the right. The tree is expanded to 'IO-Link Master' > 'Diagnostics' > 'UnderCurrentPin4'. The table lists six data points for various current pins.

#	Server	Node Id	Display Name	Value	Datatype	Source Timestamp	Server Timestamp	Statuscode
1	OPC UA ...	NS6[Numeric...	OverCurrentPin1	0	Int32	06:31:26.000	06:31:26.000	Good
2	OPC UA ...	NS6[Numeric...	OverCurrentPin2	0	Int32	06:31:26.000	06:31:26.000	Good
3	OPC UA ...	NS6[Numeric...	OverCurrentPin4	0	Int32	06:31:27.000	06:31:27.000	Good
4	OPC UA ...	NS6[Numeric...	UnderCurrentPi...	0	Int32	06:31:28.000	06:31:28.000	Good
5	OPC UA ...	NS6[Numeric...	UnderCurrentPi...	0	Int32	06:31:28.000	06:31:28.000	Good
6	OPC UA ...	NS6[Numeric...	UnderCurrentPi...	0	Int32	06:31:29.000	06:31:29.000	Good

### 8.10.3.4 Process Data

The OPC UA server provides nodes with process data. For example, the OPC UA client can read the value at pin 2 of a port in the node **Pin2ProcessData**.

Node name	Node class	Access	Description
Pin2ProcessData	Variable	Read	Process data to pin 2
Pin4ProcessData	Variable	Read	Process data to pin 4

The screenshot shows the 'Address Space' tree on the left and the 'Data Access View' table on the right. The tree is expanded to 'IO-Link Master' > 'SIOProcessData' > 'Pin2ProcessData' and 'Pin4ProcessData'. The table lists two process data nodes.

#	Server	Node Id	Display Name	Value	Datatype	Server Timestamp	Source Timestamp	Statuscode
1	OPC UA ...	NS6[Numeric...	Pin2ProcessData	false	Boolean	06:32:34.000	06:32:34.000	Good
2	OPC UA ...	NS6[Numeric...	Pin4ProcessData	false	Boolean	06:32:35.000	06:32:35.000	Good

### 8.10.3.5 Measured Values

The OPC UA server provides nodes with calculated measured values. For example, the OPC UA client can read the calculated sum current of supply line 1 in node **SumCurrentL**.

#### Device-Related Measured Values

Node name	Node class	Access	Description
SumCurrentL	Variable	Read	Total current calculated from individual measurements in supply line 1, unit: mA
SumCurrentL2	Variable	Read	Total current calculated from individual measurements in supply line 2, unit: mA
MeanTemperature	Variable	Read	Mean value for the temperature of the assembly, calculated from the temperature values measured individually at the three chips, unit: °C
MeanVoltageL	Variable	Read	Mean voltage in supply line 1, unit: mV
MeanVoltageL2	Variable	Read	Mean voltage in supply line 2, unit: mV

#	Server	Node Id	Display Name	Value	Datatype	Server Timestamp	Source Timestamp	Statuscode
1	OPC UA ...	NS6(Numeric...	SumCurrentL	89	Int32	06:34:44.000	06:34:44.000	Good
2	OPC UA ...	NS6(Numeric...	SumCurrentL2	0	Int32	06:34:25.000	06:34:25.000	Good
3	OPC UA ...	NS6(Numeric...	MeanTemperat...	34.5	Float	06:34:29.000	06:34:29.000	Good
4	OPC UA ...	NS6(Numeric...	MeanVoltageL	23837	Int32	06:34:44.000	06:34:44.000	Good
5	OPC UA ...	NS6(Numeric...	MeanVoltageL2	24245	Int32	06:34:44.000	06:34:44.000	Good

#### Port-Related Measured Values

Node name	Node class	Access	Description
CurrentPin1, CurrentPin2, CurrentPin4	Variable	Read	Current measured at pin 1, pin 2 or pin 4, unit: mA
TemperaturePin1, TemperaturePin2, TemperaturePin4	Variable	Read	Temperature measured at pin 1, pin 2 or pin 4, unit: °C
VoltagePin1, VoltagePin2, VoltagePin4	Variable	Read	Voltage measured at pin 1, pin 2 or pin 4, unit: mA

#	Server	Node Id	Display Name	Value	Datatype	Server Timestamp	Source Timestamp	Statuscode
1	OPC UA ...	NS0(Numeric...	CurrentPin1	12	Int32	06:35:57.000	06:35:57.000	Good
2	OPC UA ...	NS0(Numeric...	CurrentPin2	0	Int32	06:35:40.000	06:35:40.000	Good
3	OPC UA ...	NS0(Numeric...	CurrentPin4	0	Int32	06:35:41.000	06:35:41.000	Good
4	OPC UA ...	NS0(Numeric...	MaxTemperatur...	35,7	Float	06:35:45.000	05:54:48.000	Good
5	OPC UA ...	NS0(Numeric...	MaxTemperatur...	35,7	Float	06:35:45.000	03:17:01.000	Good
6	OPC UA ...	NS0(Numeric...	MaxTemperatur...	35,7	Float	06:35:46.000	03:17:17.000	Good
7	OPC UA ...	NS0(Numeric...	VoltagePin1	23890	Int32	06:35:57.000	06:35:57.000	Good
8	OPC UA ...	NS0(Numeric...	VoltagePin2	-113	Int32	06:35:57.000	06:35:57.000	Good
9	OPC UA ...	NS0(Numeric...	VoltagePin4	-102	Int32	06:35:57.000	06:35:57.000	Good

### 8.10.3.6 Diagnostics

The OPC UA server provides nodes with diagnostic information. For example, the OPC UA client can read in the DiagnosticsPin1 node whether the device has detected an overcurrent on pin 1 of a port.

Node name	Node class	Access	Description
DiagnosticsPin1, DiagnosticsPin2, DiagnosticsPin4	Variable	Read	<p>Diagnostics at pin 1, pin 2 or pin 4. The numeric value contains bit-coded information:</p> <ul style="list-style-type: none"> <li>• Bit 0: Short circuit,</li> <li>• Bit 1: Overload protection,</li> <li>• Bit 2: Over-temperature protection,</li> <li>• Bit 3: Overvoltage protection,</li> <li>• Bit 4: Overcurrent,</li> <li>• Bit 5: Undercurrent</li> </ul> <p>0: Diagnostics not active 1: Diagnostics active</p>

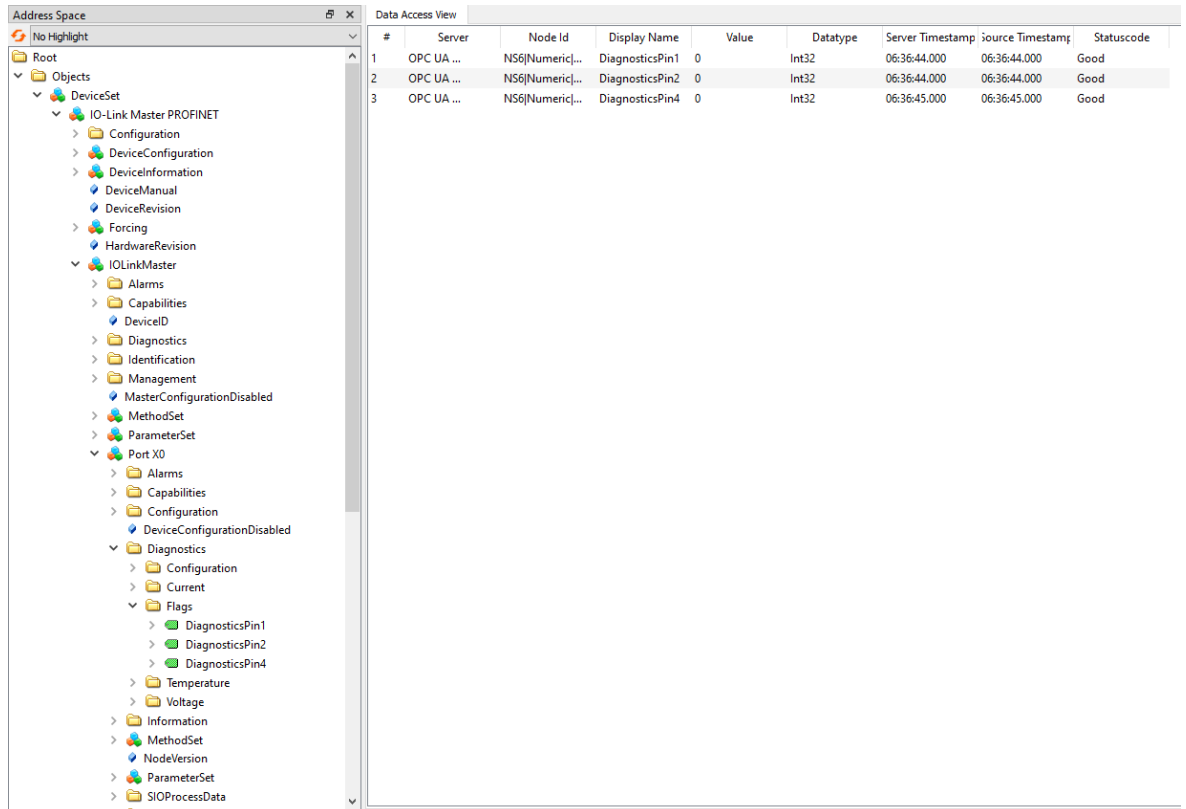

### 8.10.3.7 Statistics

The OPC UA server provides nodes with statistical information. For example, the OPC UA client can read the maximum measured current at pin 1 of a port in node **MaxCurrentPin1**.

Node name	Node class	Access	Description
<b>Current</b>			
MaxCurrentPin1, MaxCurrentPin2, MaxCurrentPin4	Variable	Read	Maximum current at pin 1, pin 2 or pin 4 since reset of value, unit: mA
MinCurrentPin1, MinCurrentPin2, MinCurrentPin4	Variable	Read	Minimum current at pin 1, pin 2 or pin 4 since reset of value, unit: mA
<b>Temperature</b>			
MaxTemperaturePin1, MaxTemperaturePin2, MaxTemperaturePin4	Variable	Read	Maximum temperature at pin 1, pin 2 or pin 4 since reset of value, unit: °C
MinTemperaturePin1, MinTemperaturePin2, MinTemperaturePin4	Variable	Read	Minimum temperature at pin 1, pin 2 or pin 4 since reset of value, unit: °C
<b>Template</b>			
MaxVoltagePin1, MaxVoltagePin2, MaxVoltagePin4	Variable	Read	Maximum voltage at pin 1, pin 2 or pin 4 since resetting the value, unit: mV
MinVoltagePin1, MinVoltagePin2, MinVoltagePin4	Variable	Read	Minimum voltage at pin 1, pin 2 or pin 4 since reset of value, unit: mV

#	Server	Node Id	Display Name	Value	Datatype
1	OPC UA Server	NS6 Numeric 34...	MaxCurrentPin1	109	Int32
2	OPC UA Server	NS6 Numeric 34...	MaxCurrentPin2	0	Int32
3	OPC UA Server	NS6 Numeric 34...	MaxCurrentPin4	0	Int32
4	OPC UA Server	NS6 Numeric 34...	MinCurrentPin1	104	Int32
5	OPC UA Server	NS6 Numeric 34...	MinCurrentPin2	0	Int32
6	OPC UA Server	NS6 Numeric 34...	MinCurrentPin4	0	Int32
7	OPC UA Server	NS6 Numeric 34...	MaxTemperaturePin1	43.7	Float
8	OPC UA Server	NS6 Numeric 34...	MaxTemperaturePin2	43.7	Float
9	OPC UA Server	NS6 Numeric 34...	MaxTemperaturePin4	43.7	Float
10	OPC UA Server	NS6 Numeric 34...	MinTemperaturePin1	42.2	Float
11	OPC UA Server	NS6 Numeric 34...	MinTemperaturePin2	42.2	Float
12	OPC UA Server	NS6 Numeric 34...	MinTemperaturePin4	42.2	Float
13	OPC UA Server	NS6 Numeric 34...	MaxVoltagePin1	23550	Int32
14	OPC UA Server	NS6 Numeric 34...	MaxVoltagePin2	-220	Int32
15	OPC UA Server	NS6 Numeric 34...	MaxVoltagePin4	-213	Int32
16	OPC UA Server	NS6 Numeric 34...	MinVoltagePin1	23525	Int32
17	OPC UA Server	NS6 Numeric 34...	MinVoltagePin2	-244	Int32
18	OPC UA Server	NS6 Numeric 34...	MinVoltagePin4	-233	Int32

### 8.10.3.8 NTP Client Configuration

The OPC UA server provides nodes for configuring the NTP client.

Node name	Node class	Access	Description
NtpClientServerIpAddress	Variable	Read/ write	<ul style="list-style-type: none"> <li>IP address of the NTP server</li> <li>The NTP client uses the set IP address to get the time from an NTP server.</li> <li>The IP address must be converted to a decimal number. The calculation is described according to the table.</li> <li>The value 0 disables the function.</li> </ul>
NtpClientServerIpAddressFallback	Variable	Read/ write	<ul style="list-style-type: none"> <li>IP address of the NTP server (fallback)</li> <li>The optional additional IP address if the NTP server cannot be reached via the IP address in node NtpClientServerIpAddress.</li> <li>The IP address must be converted to a decimal number. The calculation is described according to the table.</li> <li>The value 0 disables the function.</li> </ul>
NtpClientUpdateConfiguration	Variable	Write	Method for writing the nodes NtpClientServerIpAddress and NtpClientServerIpAddressFallback.

The following formula is used to convert the IP address to a decimal number. Starting from an IP address in A.B.C.D format:

$$((A * 256 + B) * 256 + C) * 256 + D = \text{IP address as a decimal number}$$

Example for IP address 192.53.103.108

---

$$((192 * 256 + 53) * 256 + 103) * 256 + 108 = 3224725356$$

---

### 8.10.3.9 OPC UA PC Client

The IO-Link master is equipped with an integrated web server. With an OPC UA client, you can communicate with the IO-Link master.

For test purposes, the UaExpert from Unified Automation GmbH can be used, for example: [www.unifiedautomation.com](http://www.unifiedautomation.com)

An OPC UA client can access the IO-Link master in read mode with “anonymous” authentication.

An OPC UA client can access the IO-Link master in read and write mode with the authentication “User name and password” if the user used has write permissions.

## Connect to IO-Link Master

### Prerequisites

- You have an OPC UA client.
- If you want to write to the IO-Link master: You know the username and password and have write access.
- You know the IP address of the IO-Link master.

Without a user name and password, you can access the IO-Link Master “anonymously” and read data.

### Step-by-Step Instructions

Establish a connection to the IO-Link master:

- Start UaExpert
- Use File > New to create a new project.
- Use Server > Add to add a new server.

The Add Server dialog appears with the Discovery tab.

### Discovery tab (default)

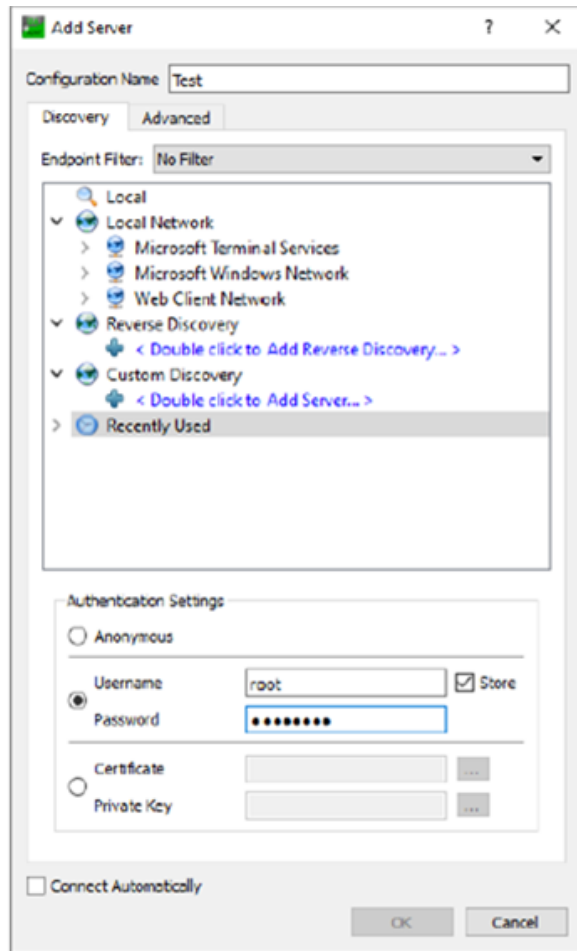

### Advanced tab

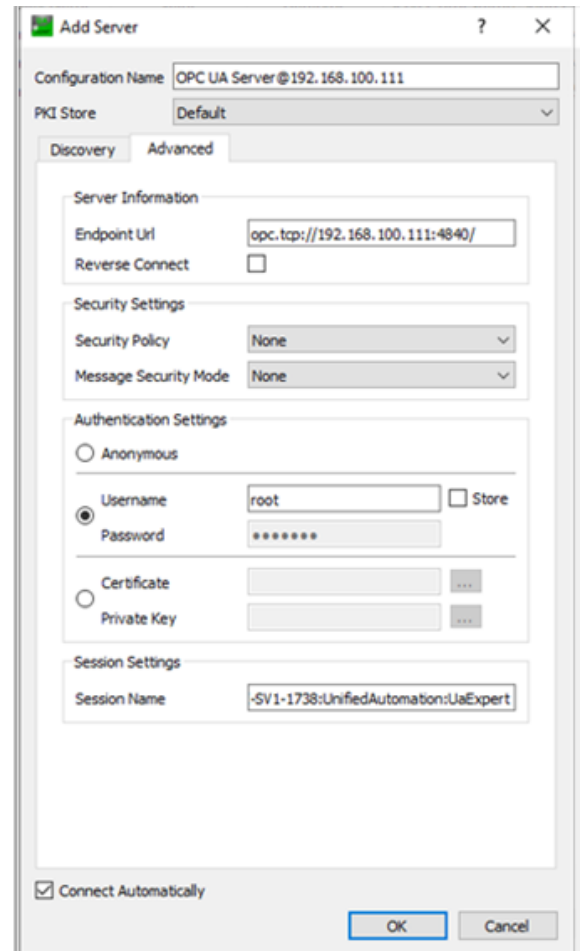

- In the Configuration name field, enter a name for your configuration, e.g. Test.
- Select the Advanced tab.
- In the Server Information section of the Advanced tab, enter the following in the Endpoint Url data field: `opc.tcp://<IP Address>;4840` For <IP Address>, enter the device's IP address.
- In the Authentication Settings area, select Username/Password if you want write access to the device or Anonymous if read access is sufficient.
- If you have selected the Username/Password option, enter your username and, if applicable, your password there.
- Then click OK.

In the project window, the UaExpert enters the server under Project >Servers, e.g. Test.

- Open the context menu of the server (Test) and select Connect.

The connection is established.

### Prerequisites

- You have an OPC UA client.
- You know the username and password and have write access.
- You know the IP address of an NTP server.
- You have converted the IP address of this NTP server to a decimal number as described below.
- You have already established a connection to the MVK device.

### Example of an NTP Server

NTP server ptbtime1.ptb.de of the Physikalisch-Technische Bundesanstalt in Braunschweig with the IP address 192.53.103.108

Replacement NTP server (optional) of the NTP server ptbtime2.ptb.de of the Physikalisch-Technische Bundesanstalt in Braunschweig with the IP address 192.53.103.104

Converting an IP address to a decimal number

The following formula is used to convert the IP address to a decimal number. Starting from an IP address in A.B.C.D format:

---

$$((A * 256 + B) * 256 + C) * 256 + D = \text{IP address as a decimal number}$$

---

Example for IP address 192.53.103.108

---

$$((192 * 256 + 53) * 256 + 103) * 256 + 108 = 3224725356$$

---

### Step-by-Step Instructions

- In the Address Space window, open the context menu:

Root> Objects> DeviceSet> [Device name] > Configuration> NtpClient>NtpClientUpdateConfiguration.

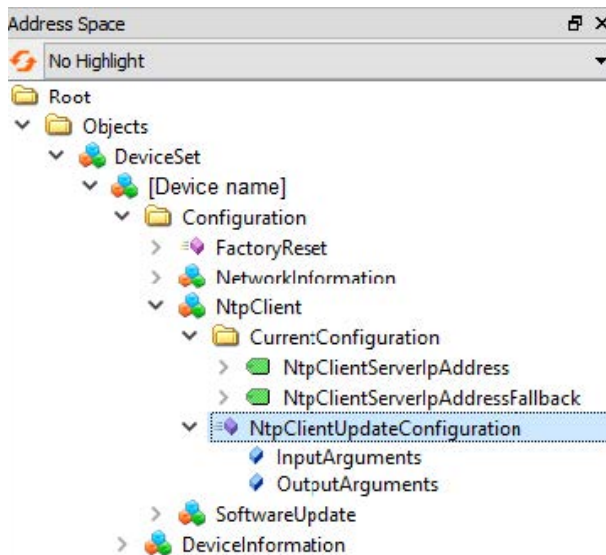

- Select Call from the context menu.

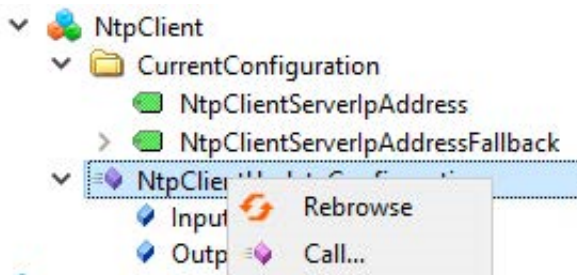

The Call **NtpClientUpdateConfiguration on NtpClient** dialog box is displayed:

Input Arguments			
Name	Value	DataType	Description
ServerIpAddress	3224725356	UInt32	
ServerIpAddressFallback	3224725352	UInt32	

Output Arguments			
Name	Value	DataType	Description
Status		Int32	

Result

Call Close

- In the **Input Arguments** area, enter the value 3224725356 in the **ServerIpAddress** input field for the IP address of the NTP server.
- In the **Input Arguments** area, enter the number 3224725352 in the **ServerIpAddressFallback** input field for the IP address of the replacement NTP server.
- Click **Call**.

If the function call was successful, the output field to the right of Status in the **Output Arguments** area displays the value 0. A green bar with the text “Succeeded” is displayed in the **Result** area.

The two variables ServerIpAddress and ServerIpAddressFallback are now set. The device obtains the current time from the time server via NTP and synchronizes its internal time.

Input Arguments			
Name	Value	DataType	Description
ServerIpAddress	3224725356	UInt32	
ServerIpAddressFallback	3224725352	UInt32	

Output Arguments			
Name	Value	DataType	Description
Status	0	Int32	

Result
Succeeded

Call Close

## 9 Operation

### 9.1 LED Display

The device has separate and clearly arranged displays:

- LED display for inputs and outputs
- LED display BUS
- LED display POWER
- Advanced LED displays

In order to assure unequivocal allocation of displayed information, the LEDs are correspondingly identified at the device's front panel. Displays include static illumination and blinking LEDs.

#### 9.1.1 LED Assignment to Channel and Pin

A separate status display is assigned to each input and output.

- LED of channel 0X (X=port number) is assigned to pin 4.
- LED of channel 1X (X=port number) is assigned to pin 2.

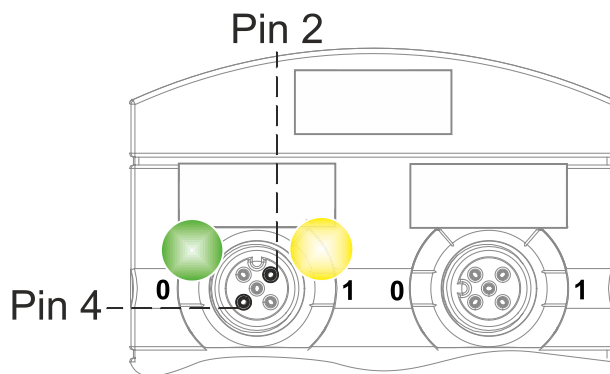

### 9.1.2 \* Flashing Behavior:

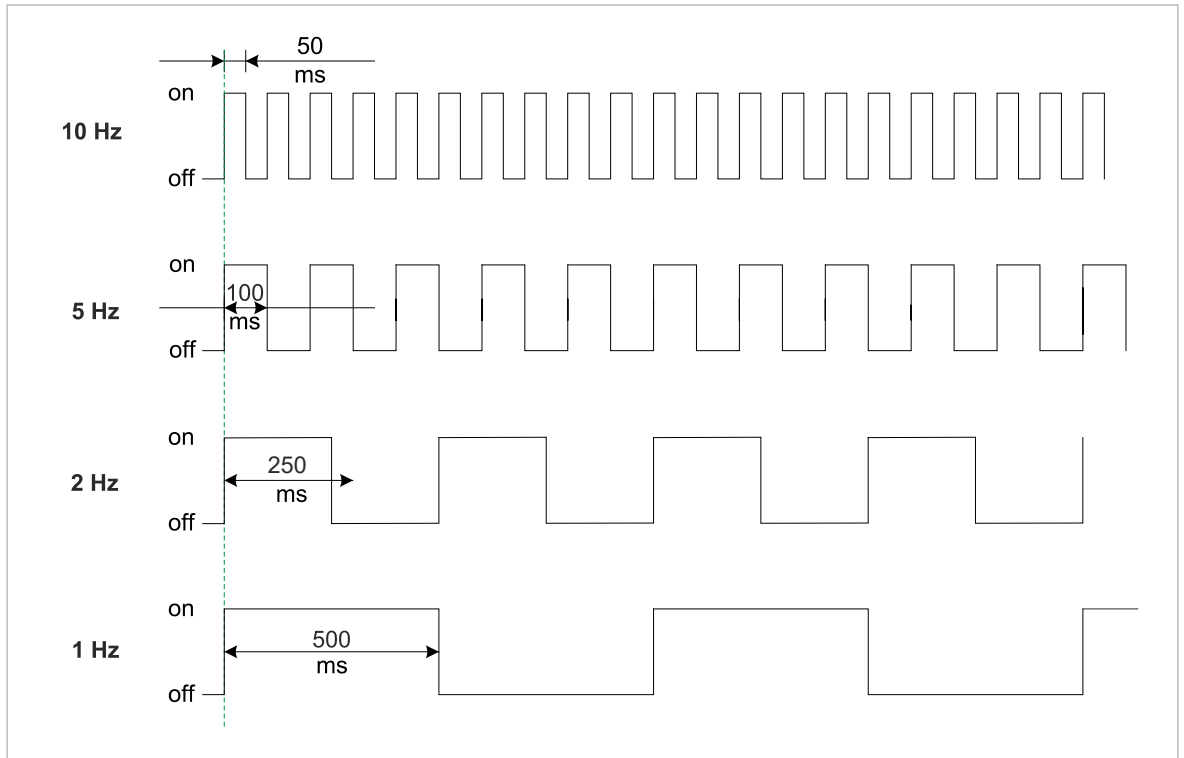

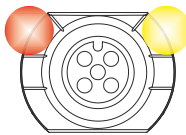

### 9.1.3 LED Display for Inputs and Outputs







A separate status display is assigned to each input and output.

#### Pin 2 Digital Input DI

Indicator	Status	Description
 Yellow	Continuous light	Fixed configuration: DI (NO) visible in process data. 24 V
 Red	Flashing 1 Hz	Overload/short-circuit of the sensor supply 24 V + Pin 1
	Off	Pin 2 is not used or is switched off

#### Pin 2 Digital Output DO



Indicator	Status	Description
 Yellow	Continuous light	Fixed configuration: DO can be switched via process data 24 V
 Red	Continuous light	Overload/short circuit at pin 2
	Flashing 1 Hz	Overload/short-circuit of the sensor supply

Indicator	Status	Description
Red		24 V + Pin 1
	Off	Pin 2 is not used or is switched off





## Input or Output Error

If an error occurs on an input or output, the corresponding LED on the M12 slot lights up red.







## Pin 4 Digital Input DI

Indicator	Status	Description
	Continuous light	Fixed configuration: DI (NO) visible in process data
Yellow		24 V
	Flashing 1 Hz	Overload/short-circuit of the sensor supply
Red		24 V + Pin 1
	Off	Pin 4 is not used or is switched off

## Pin 4 Digital Output DO

Indicator	Status	Description
	Continuous light	Fixed configuration: DO can be switched via process data 24 V
Yellow		
	Continuous light	Overload/short circuit at pin 4
Red		
	Flashing 1 Hz	Overload/short-circuit of the sensor supply
Red		24 V + Pin 1
	Off	Pin 4 is not used or is switched off

## Pin 4 IO-Link Mode

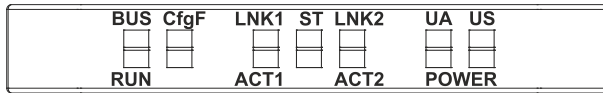

Indicator	Status	Description
	Continuous light	IO-Link in status Operate.
Green		
	Flashing 1 Hz	<ul style="list-style-type: none"> <li>Device is not connected</li> <li>No communication with connected device.</li> </ul>
Green		
	Flashing 10 Hz	<ul style="list-style-type: none"> <li>IO-Link in Pre-Operate status during data retention</li> <li>Validation failed. Incompatible IO-Link device connected.</li> </ul>
Green		
	Continuous light	Overload/short circuit at pin 4
Red		
	Flashing 1 Hz	<ul style="list-style-type: none"> <li>Validation failed.</li> <li>Incompatible IO-Link device connected for data storage.</li> <li>Data storage failed.</li> </ul>
Red		
	Off	IO-Link connection deactivated.

## 9.1.4 BUS RUN and CfgF LED





- BUS RUN shows the status of the bus system.
- CfgF shows the status of the PLC configuration.

### LED Display BUS\_RUN

Indicator	Status	Description
 Red	Continuous light	No configuration, no connection
 Red	Flashing 2 Hz	No data exchange
 Off		Trouble-free operation

### LED Display CfgF

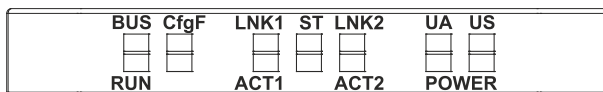

Indicator	Status	Description
 Red	Continuous light	a   Channel, generic or advanced Diagnostics available b   Watchdog timeout c   System error
 Red	Flashing 1 Hz 3 s	DCP signal service initiated via bus
 Off		Trouble-free operation

## 9.1.5 LED Display LNK/ACT





- LNK/ACT (Link/Activity) show the status of the EtherCAT communication on the respective port.

### LED Display LNK

LED display	LED status	Description
 Green	Continuous light	Connection to the network established.
 Off		No connection to network.

## LED Display ACT

LED display	LED status	Description
 Yellow	Flashing	The device sends/receives Ethernet frames
 Off		The device is not sending/receiving Ethernet frames

## LED Display Off

You can do this:



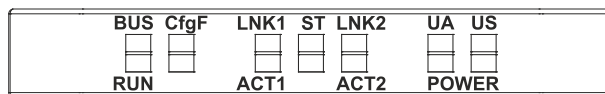

- Check the cable connections

## 9.1.6 LED Display Status



- ST – indicates the status of the entire device.

## LED Display ST

LED display	LED status	Description
 Green	Continuous light	Connection to the network established.
 Green	Flashing 4 Hz	The process requested by the position of the rotary switch is carried out. Do not switch off the device.
 Red	Flashing 2 Hz	Invalid rotary switch position. The system will not start.
 Red	Continuous light	No connection to network.

## Red LED Flashes

You can do this:

- Select a valid position.
- Restart the device.



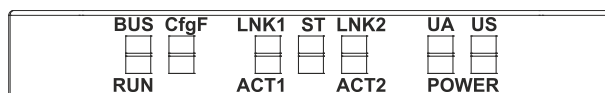

## 9.1.7 LED Display POWER US and UA







The power LEDs indicate the status of the supply voltages

- UA actuator voltage
- US operating voltage

## LED Display POWER US

LED display	LED status	Description
 Green	Continuous light	$18\text{ V} \leq \text{US} \leq 30\text{ V}$ Trouble-free operation
 Red	Continuous light	$11\text{ V} \leq \text{US} \leq 18\text{ V}$ Undervoltage
 Red	Flashing 4 Hz	$\text{US} > 30\text{ V}$ Overvoltage
 Red	Off	$\text{US} < 11\text{ V}$ No voltage

## LED Display POWER UA

LED display	LED status	Description
 Green	Continuous light	$18\text{ V} \leq \text{UA} \leq 30\text{ V}$ Trouble-free operation
 Red	Continuous light	$11\text{ V} \leq \text{UA} \leq 18\text{ V}$ Undervoltage
 Red	Flashing 4 Hz	$\text{UA} > 30\text{ V}$ Overvoltage
 Red	Off	$\text{UA} < 11\text{ V}$ No voltage



## INFORMATION

At  $\text{US} < 18\text{ V}$ , fault-free operation is no longer guaranteed.

### 9.1.8 Advanced LED Display

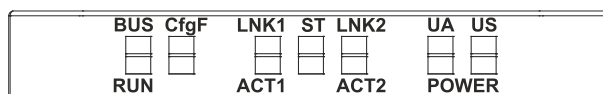

#### Identification of the Device

LED	Indicator	Status	Description
CfgF	 Red	Flashes 3 times 1 Hz	Identification of the device

## 9.2 PROFINET Diagnostics

### Alarm

The IO-Link master sends diagnostic information in the form of alarms according to the PROFINET specification V2.3.



### INFORMATION

Diagnostics are reported to the PLC in the form of “coming” and “going” alarms. If an alarm is only present for a short time, it is advantageous if there is a diagnostic buffer in the PLC. This diagnostic buffer can be used to subsequently evaluate the alarm details. If the PLC does not provide a diagnostic buffer, it should be created as user software.

### 9.2.1 Device-Related Diagnostic Messages

Channel Error type	Meaning	Measure
0x0100	Sensor undervoltage	Check the sensor supply voltage of the device.
0x0101	Sensor overvoltage	Check the sensor supply voltage of the device.
0x0102	Device overheats	Remove heat source.
0x0103	Current overload sensor	Check current consumption of connected load
0x0104	Actuator current overload	Check current consumption of connected load
0x0105	Device undercooled	Insulate device.
0x0106	Actuator undervoltage	Check the actuator supply voltage of the device.
0x0107	Actuator overvoltage	Check the actuator supply voltage of the device.
0x0108	Force mode active	Disable force mode via WebUI/OPC-UA/JSON.
0x0109	Short-circuit pin 2/4	Check the wiring to the relevant socket.
0x010A	Short-circuit pin 2/2	Check the wiring to the relevant socket.
0x010B	Short-circuit pin 2/1	Check the wiring to the relevant socket.
0x010C	No actuator voltage	Check the actuator supply voltage of the device.
0x010D	No connection to NTP server	Check the SNTP parameters and the connection to the NTP server.
0x010E	NTP synchronization lost	Check the connection to the NTP server.

### 9.2.2 Diagnostic Messages to IO-Link Ports via IODD

Channel Error type	Extended chan- nel Error type	Meaning	Measure
0x10 (16)	0x50E0 (20704)	IODD on board: Error in GSDML	Please contact wenglor.
0x10 (16)	0x50E0 (20704)	IODD on board: General error	Please contact wenglor
0x10 (16)	0x50E1 (20705)	IODD on board: Error in GSDML	Please contact wenglor
0x10 (16)	0x50E2 (20706)	IODD on board: Error in GSDML	Please contact wenglor
0x10 (16)	0x50E3 (20707)	IODD on board: Error in GSDML	Please contact wenglor
0x10 (16)	0x50E4 (20708)	IODD on board: Error in GSDML	Please contact wenglor
0x10 (16)	0x50E5 (20709)	IODD on board: Invalid parameter value	Check the parameterization of the device.
0x10 (16)	0x50E6 (20710)	IODD on board: Invalid parameter value	Check the parameterization of the device.

Channel Error type	Extended channel Error type	Meaning	Measure
0x10 (16)	0x50E7 (20711)	IODD on board: Invalid parameter value	Check the parameterization of the device.

## 9.2.3 Diagnostic Messages to IO-Link Ports

### 9.2.3.1 According to IO-Link Integration Guideline Issue 2

The listed diagnoses are available when the IO-Link event integration parameter "Parameter 16" is set to "After IO-Link Integration Guideline Issue 2".

Channel error type	Extended channel error type	IO-Link event code	Meaning
0x9502	0x0000 – 0x7FFF	0x0000 – 0x7FFF	IO-Link master event. The Extended Channel Error Type corresponds to the original IO-Link event code.
0x9500	0x0000 – 0x7FFF	0x0000 – 0x7FFF	IO-Link device event. The Extended Channel Error Type corresponds to the original IO-Link event code.
0x9501	0x0000 – 0x7FFF	0x8000 – 0xFFFF	IO-Link device event. The Extended Channel Error Type plus 0x8000 (32768) corresponds to the original IO-Link event code.



## INFORMATION

The meaning of the IO-Link event codes can be found in the Profinet specification IO-Link Integration – Edition 2, Version 1.1 (IO-Link-Integration-for-PROFINET\_Ed2\_2832\_V11\_Feb20.pdf) or in the document IO-Link Interface and System, V1.1.3 (IOL-Interface-Spec\_10002\_V113\_Jun19.pdf) of the IO-Link Community.

# 10 Web Server

The wenglor web server is a graphical tool with which you can quickly and intuitively obtain information about the device.

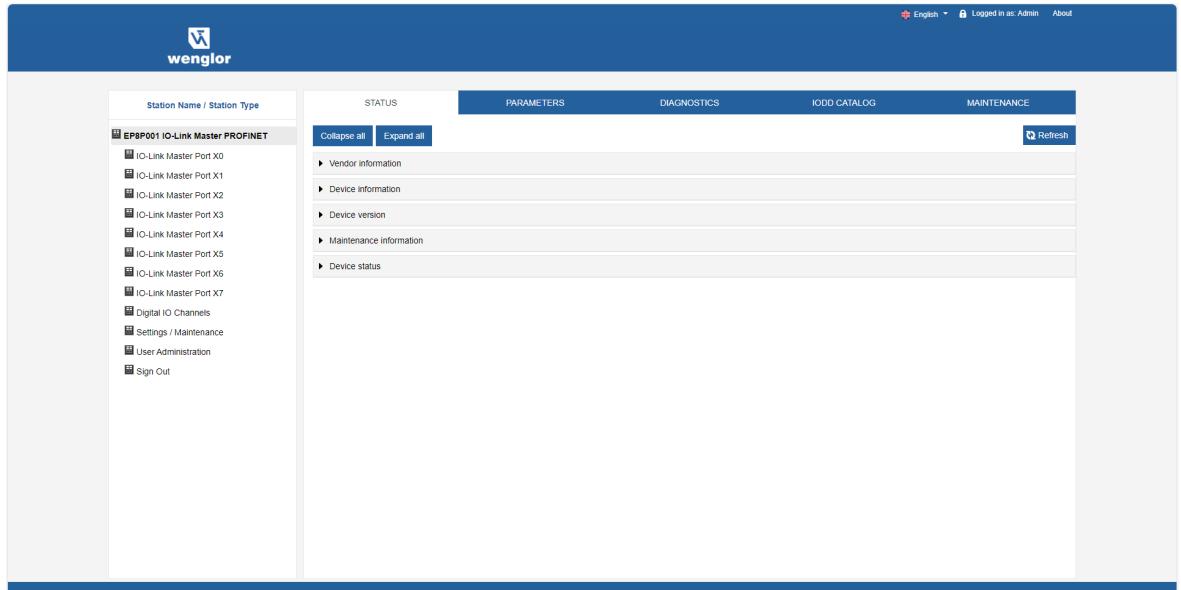

The devices mentioned in the screenshots serve as examples.

## 10.1 Start Web Server

### Prerequisites

Prerequisite for a correct graphical representation of the web server:

The following browsers with HTML5 and ES5 are supported by:

- Mozilla Firefox
- Microsoft Edge
- Google Chrome

To start the web server, proceed as follows:

- Start the web browser.
- Enter the IP address of the device in the web browser. The start screen of the web server is displayed.

## 10.2 Access and Login

### Username and Password

Username and password at first startup

1. At first start-up, enter the login details for user name and password:

- a) User name <admin>
- b) Password <private>

Second Click on Login.

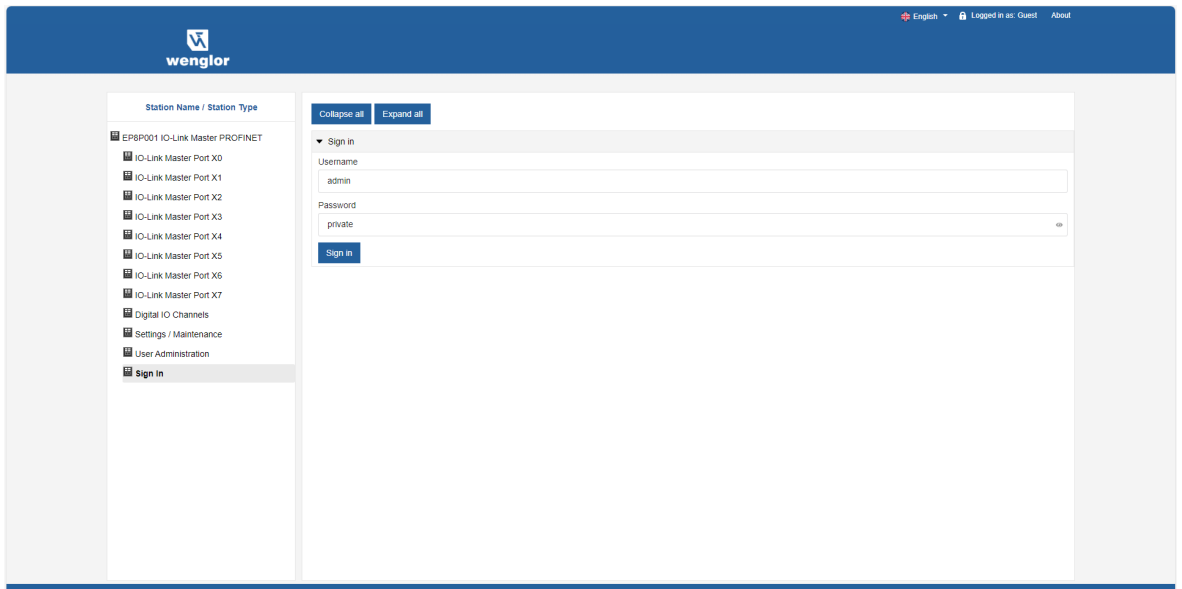

## Change Password



### INFORMATION

#### Ensure data security.

→ Change user name and password after the first login and after each factory reset.

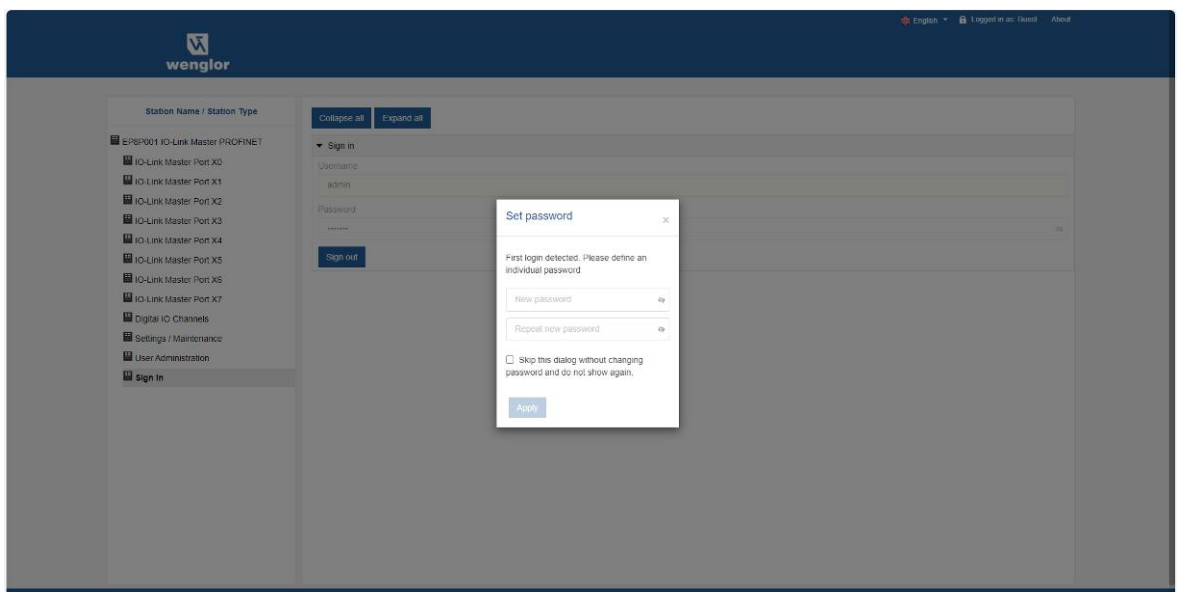

## 10.3 Start Screen

### Operating Ranges

The web server is divided into 4 operating areas.

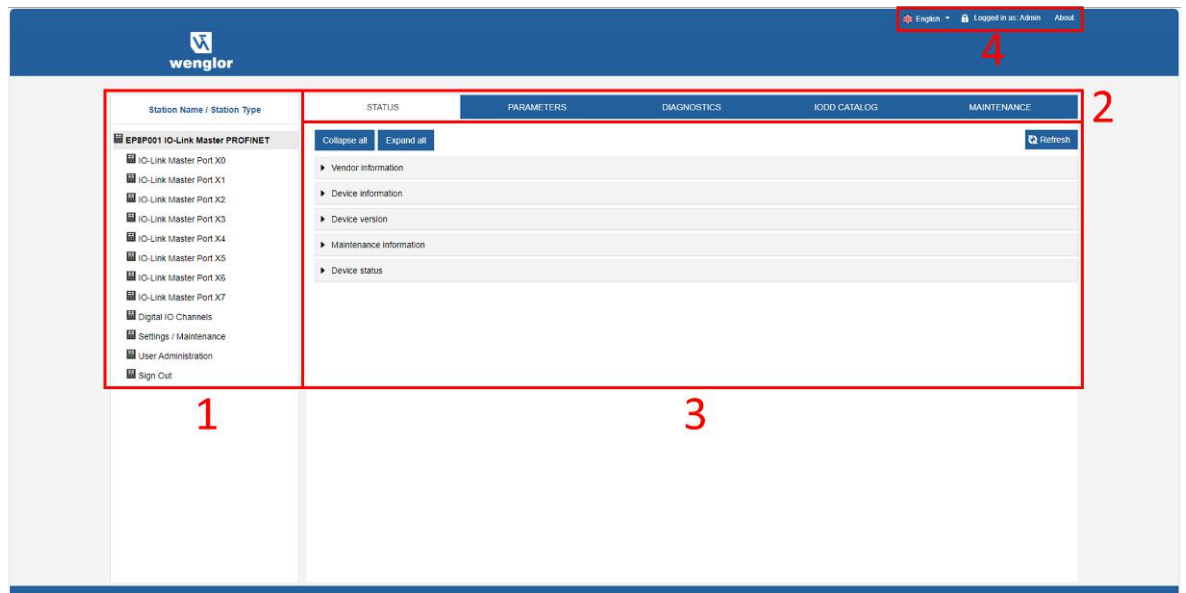

1. **System tree**

This shows the device and available sub-functions.

2. **Menu bar**

The menu bar can be used to switch between the different pages of the device or the subfunction. In addition, the white highlighting shows which page you are currently on.

3. **Page content**

This area displays the content of the selected page.

4. **Header bar**

Language and interface settings, system information.

## 10.4 Menu Bar

The first line of the system tree displays the device with article number and product name.

The menu bar contains the following clickable menu items:

- STATUS
- PARAMETER
- DIAGNOSTICS
- IODD CATALOG
- MAINTENANCE

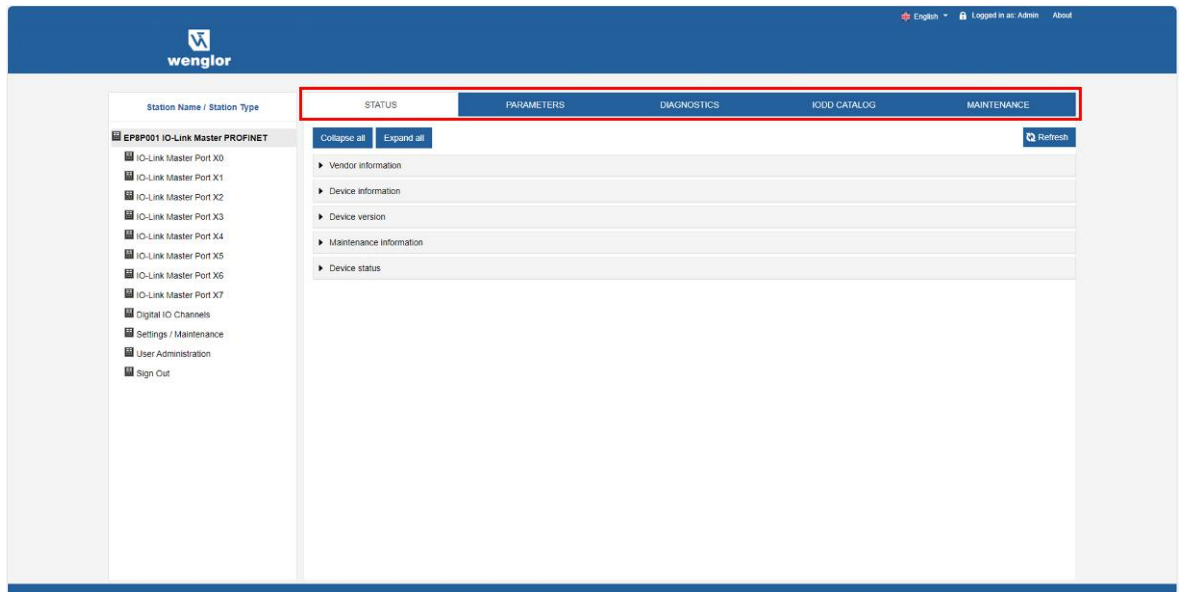

## 10.4.1 STATUS Menu

The “Status” menu item contains the following sub-items:

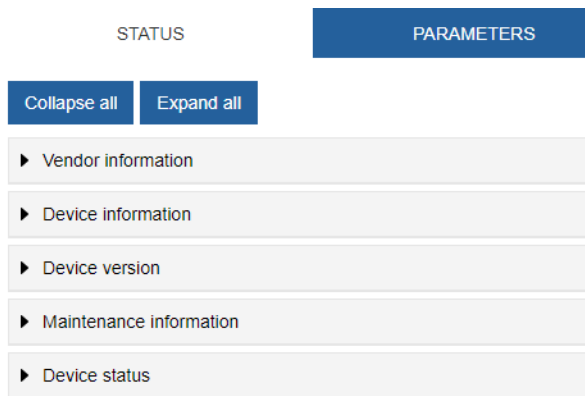

### Manufacturer Information

“Manufacturer information” shows the following information:

Parameter name	Meaning
Manufacturer name	Fixed manufacturer data
Manufacturer address	Fixed manufacturer data
Manufacturer phone	Fixed manufacturer data
Manufacturer URL	Manufacturer website

### Device Information

“Device information” displays the following information:

Parameter name	Meaning
Order Number	Article number of the device
Hardware name	Fixed article designation of the device
Software name	Device fieldbus designation
Software number	Serial number of the device

## Device Version

“Device version” shows the following information:

Parameter name	Meaning
Hardware version	Version of hardware
Software version	Current software version in the device
Website version	Current version of the web server in the device

## Maintenance Information



### INFORMATION

The maintenance information can only be read here. The fields are entered or changed via “Settings/Maintenance → Maintenance information”.

“Maintenance information” displays the following information:

Parameter name	Meaning
Name	Device name, free text
Installation location	Place name, free text
Contact information	Contact, free text
Description	Description, free text
Last maintenance date (yyyy-mm-dd)	Free date entry
Next maintenance date (yyyy-mm-dd)	Free date entry

## IO-Link Device Information

Parameter name	Meaning
1L voltage [V]	Display of sensor voltage in volts
1L current [A]	Display of sensor voltage in amperes
2L voltage [V]	Display of sensor voltage in volts
2L current [A]	Display of sensor voltage in amperes
Temperature [°C]	Display of the device temperature in Celsius
Total operating time [hh:mm:ss] Number of starts	Operating time since the device was switched on
Number of starts	Number of device restarts

## 10.4.2 PARAMETERS Menu

The “Parameters” menu item contains the following sub-items:

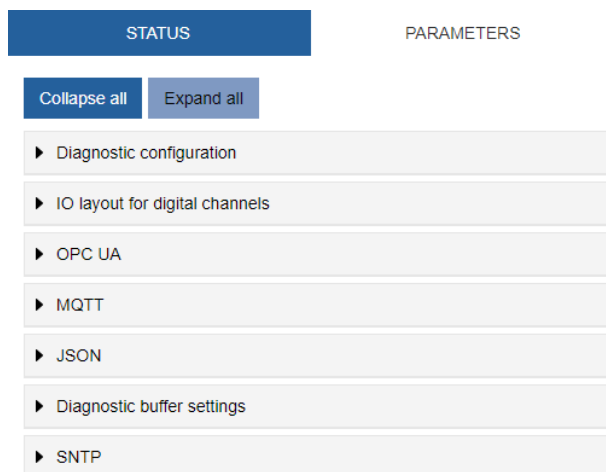

### OPC UA

Users with Admin and Operator rights can change settings and enter the OPC UA port number. Guest users have read access.

OPC UA displays the following information:

Parameter name	Meaning
Enable OPC UA Server	OPC-UA server on the module active/passive
Allow OPC UA clients to write ISDU data	OPC-UA client may write ISDU data (Indexed Service Data Unit) to the module on the IO-Link master
Allow OPC UA clients to write PDO data	OPC-UA client is allowed to write PDO (process data objects) to the assembly on the IO-Link master
OPC UA port number	Display/definition of OPC-UA port

### MQTT

Users with admin and operator rights can change settings and enter the IP address of the MQTT server. Guest users have read access.

“MQTT” shows the following information:

Parameter name	Meaning
Activate MQTT	MQTT client on the assembly active/passive
MQTT server IP address	IP address of the MQTT server
MQTT Client ID	Read/Write MQTT Client ID
Client head topic	Reading/writing an MQTT topic
Topic for system	Reading/writing an MQTT topic

### JSON

Users with admin and operator rights can enable and disable JSON. Guest users have read access.

“JSON” shows the following information:

Parameter name	Meaning
Activate JSON	JSON interface on the module active/passive

## 10.4.3 DIAGNOSTICS

The “Diagnostics” menu item displays the incoming and outgoing alarms of the master.

The menu shows an overview of the diagnostic messages.

Depending on the setting in the “Please select an entry” drop-down menu, the following diagnostics of the device are displayed:

- Enabled
- All diagnoses pending at the time of the web server call.
- All diagnoses that no longer exist are not displayed.
- History
- All diagnoses no longer available from the residual diagnostic memory are displayed.
- More than 40 diagnoses in memory. The latest diagnostics overwrites the oldest in the memory.

The screenshot displays the Wenglor web interface. The top navigation bar includes the Wenglor logo, language selection (English), and user information (Logged in as: Admin). The main interface has a left sidebar with a navigation menu and a top navigation bar with tabs for STATUS, PARAMETERS, DIAGNOSTICS, IODD CATALOG, and MAINTENANCE. The DIAGNOSTICS tab is selected, showing a dropdown menu labeled "Please select an entry:" with "Active" selected. Below this is a table of diagnostic events with columns for Key, Description, Channel, Severity, Type, and Time. A single event is visible: "IO-Link master event" with description "No Device (communication)", channel "0", severity "Fault", type "Occured", and time "0006 13:15:14".

Key	Description	Channel	Severity	Type	Time
IO-Link master event	No Device (communication)	0	Fault	Occured	0006 13:15:14

## 10.4.4 IODD CATALOG Menu

In the “IODD CATALOG” menu item, users can manage the IODD files on the device.

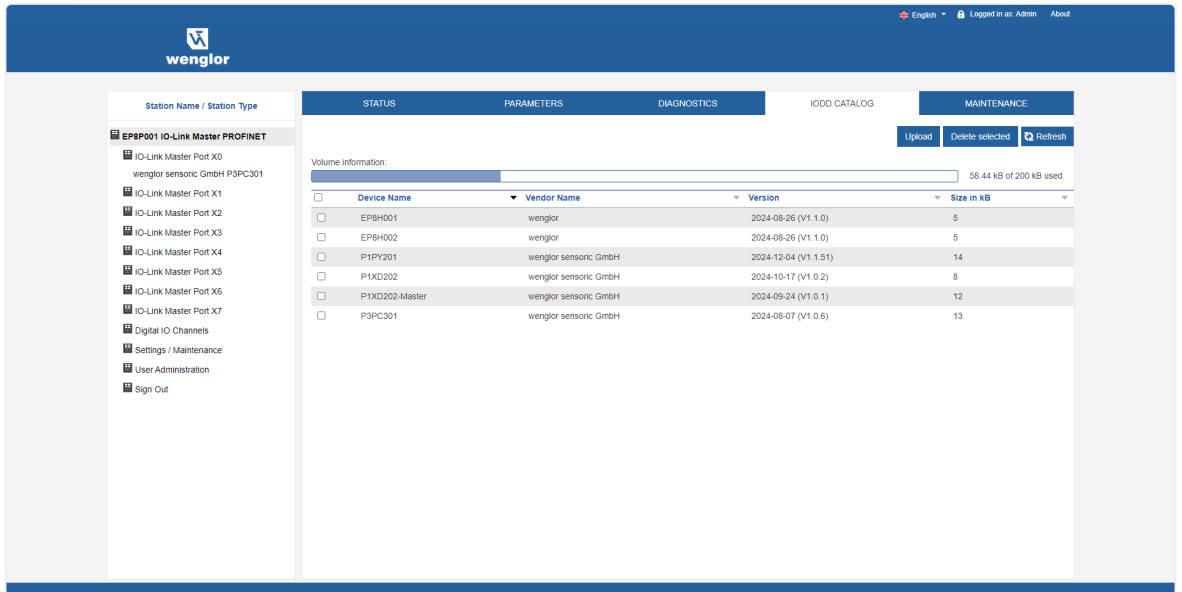

## 10.4.5 MAINTENANCE Menu

Users with administrator and operator rights can delete the diagnostic memory in the “Maintenance” menu item.

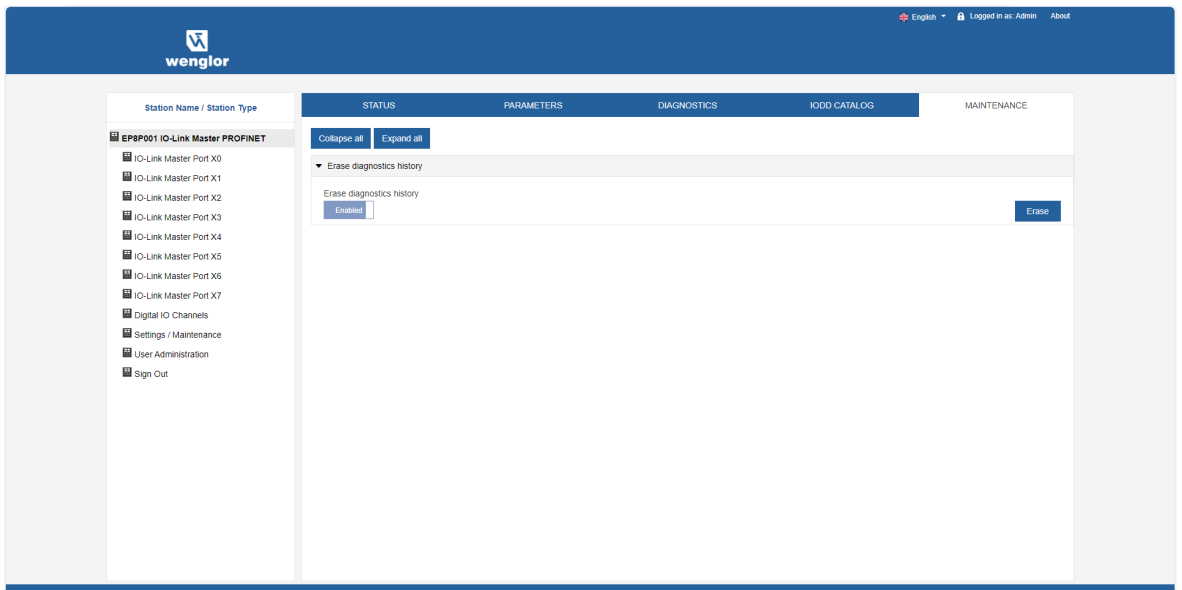

## 10.5 IO-Link Master Port

The system tree displays 8 IO-Link master ports (X0 ... X7), which can be selected individually. Depending on the user role, information can be read or functions configured here. When IO-Link communication is active, the IO-Link device name automatically appears under the relevant port.

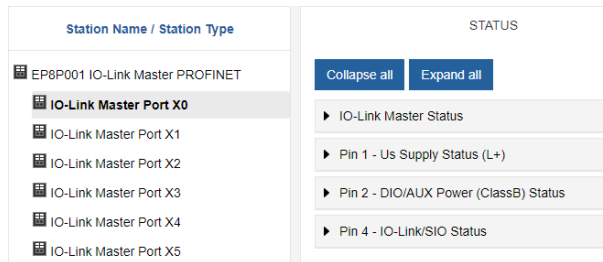

### 10.5.1 STATUS Menu

The IO-Link master status is displayed here in the Status menu.

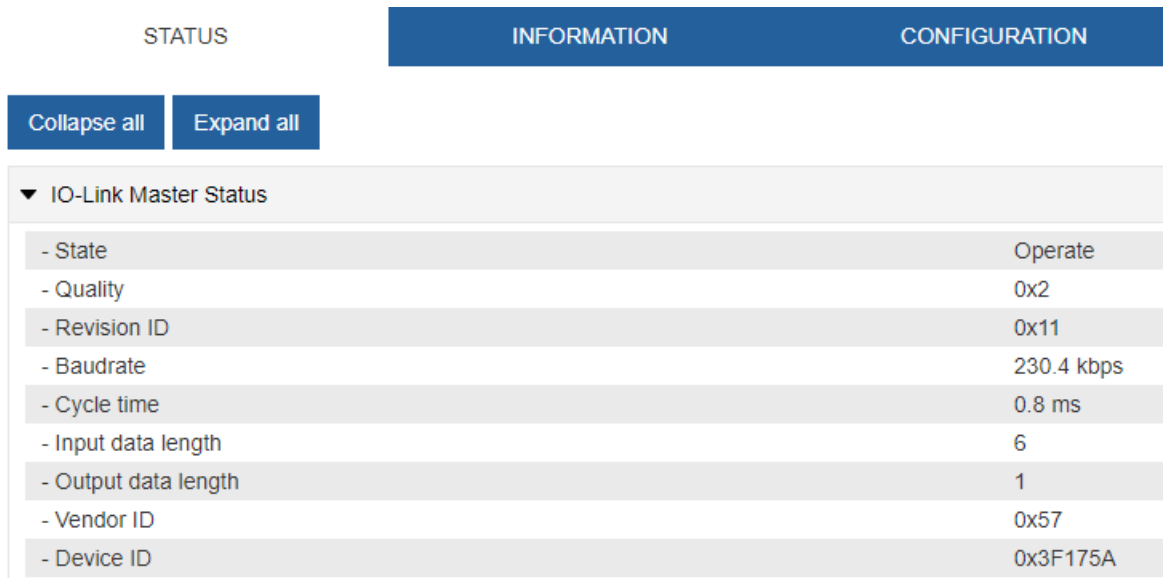

If pin 4 is in IO-Link mode, all relevant IO-Link data including the I/O bytes of the device are displayed (see Fig. 10-10: "IO-Link Master Port – IO-Link Master Status").

If pin 4 is in operation without an IO-Link device connected, it is displayed that no device is connected.

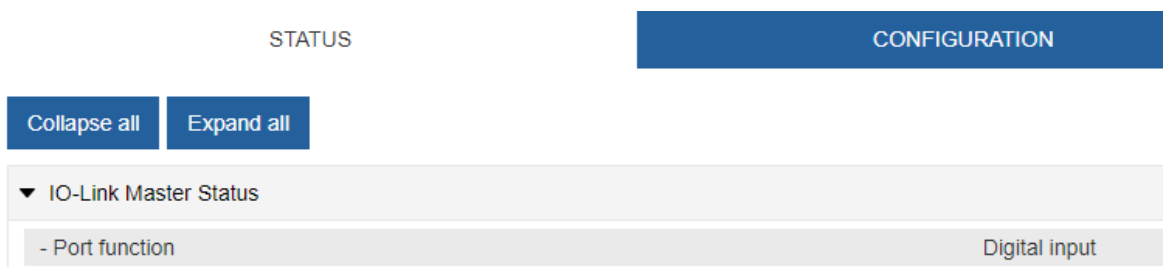

For example, if pin 4 is configured as a digital input, this is also displayed here (see Fig. 10-11: "IO-Link master port – IO-Link master status in digital mode").

Possible status displays:

- Status: Deactivated
- Status: Digital input
- Status: Digital output

### Port Status – Pin 1

“Port Status – Pin 1” displays the following information

Parameter name	Meaning
Temperature [°C]	Temperature in degrees Celsius
Voltage [V]	Voltage in volts
Current [A]	Current in amps
Status	Status of pin

### Port Status – Pin 2

“Port Status – Pin 2” displays the following information

Parameter name	Meaning
Temperature [°C]	Temperature in degrees Celsius
Voltage [V]	Voltage in volts
Current [A]	Current in amps
Status	Status of pin

### Port Status – Pin 4

“Port Status – Pin 4” displays the following information

Parameter name	Meaning
Temperature [°C]	Temperature in degrees Celsius
Voltage [V]	Voltage in volts
Current [A]	Current in amps
Status	Status of pin

## 10.5.2 INFORMATION Menu

The “Information” menu item contains the following sub-items:

STATUS
INFORMATION
CONFIGURATION
IO-LINK PARAMETERS

Collapse all
Expand all

▼ IO-Link Device Information

- Min cycle time	0.8 ms
- Function ID	0
- Number of profile IDs	4
- Vendor name	wenglor sensoric GmbH
- Vendor text	the innovative family
- Product name	P3PC301
- Product ID	P3PC301
- Product text	Laser Distance Sensor Triangulation
- Serial number	750073271
- Hardware revision	V01.00.00
- Firmware revision	V01.00.00

## IO-Link Device Information

The technical data and manufacturer information of a connected and active IO-Link device on the corresponding master port are displayed here.

“IO-Link Device Information” displays the following information:

Parameter name	Meaning
Min. cycle time	Minimum process cycle time of the IO-Link device
Function-ID	Function ID of the IO-Link device
Number of profile IDs	Number of profiles supported by the IO-Link device
Manufacturer name	Manufacturer name of the IO-Link device
Manufacturer text	Manufacturer text of the IO-Link device
Product name	Product name of the IO-Link device
Product ID	Article number of the IO-Link device
Product text	Additional description of the IO-Link device
Serial number	Serial number
Hardware status	Hardware status
Firmware status	Firmware status

### 10.5.3 CONFIGURATION Menu

In the “Configuration” menu item of the selected IO-Link port, the setting of pin 1, pin 2 and pin 4 on the selected port is displayed and can be configured there.

Users with Operator and Admin rights can set the functions and behavior of Pin 1, Pin 2 and Pin 4.

Users with service and maintenance rights have read access.

Pin 4 can be deactivated or configured as IO-Link master, input or output.

The screenshot shows the configuration interface for an IO-Link port. At the top, there are four tabs: STATUS, INFORMATION, CONFIGURATION (selected), and IO-LINK PARAMETERS. Below the tabs are two buttons: 'Collapse all' and 'Expand all'. The main content area is a list of expandable sections:

- ▼ Port Functions - Pin 4
  - Port function: A dropdown menu is open, showing options: IO-Link autostart, Deactivated, IO-Link manual configuration, IO-Link autostart (highlighted), Digital Input, normally open, Digital Input, normally closed, and Digital output.
  - Digital input signal filter
  - Output current limitation for DIO
- ▶ Port Functions - Pin 2
- ▶ Port Functions - Pin 1
- ▶ Port Diagnostics
- ▶ IODD Assignment

Pin 2 can be deactivated or configured as input, output or DIO in “Automatic Mode”.

If pin 2 or pin 4 is configured as an input, the digital input filters can be set individually.

## 10.5.4 IO-LINK PARAMETERS Menu

This menu item can be used to read and write the ISDU (Index Service Data Unit) of the device during IO-Link operation. This primarily allows an IO-Link device to be evaluated or parameterized without a control system. The input can be made in both Hex and ASCII format.



### INFORMATION

Follow the instructions in the IO-Link device manufacturer’s manual.

Users with maintenance and admin rights can write ISDU values. Users with service rights have read access.

## 10.5.5 PROCESS DATA Menu

In the “Process data” menu item, the current process data of the connected IO-Link device is displayed continuously if pin 4 of the corresponding port has been configured as an IOL port. Example: Port X2: Pin 4 (IO-Link Autostart) and Pin 2 (Digital output static on).

STATUS	INFORMATION	CONFIGURATION	IO-LINK PARAMETERS	PROCESS DATA
<b>Collapse all</b> <b>Expand all</b>				
▼ Process Data				
Pin 4 IOL Input				00,07,0b,d0,fa,03
Pin 4 IOL Output				00
Force Pin 4 IOL Output Data			<b>Write</b> <b>Disable Forcing</b>	0
Pin 2 DO				1
Pin 2 DI				1
Format				Hexadecimal ▼

This menu item displays the current statuses of the digital inputs. Example: Port X1: Pin 4 (DI) and Pin 2 (DI)

STATUS	CONFIGURATION	PROCESS DATA
<b>Collapse all</b> <b>Expand all</b>		
▼ Process Data		
Pin 4 DI		1
Pin 2 DO		1
Pin 2 DI		1
Format		Hexadecimal ▼

## 10.6 Digital IO Channels / IO Overview

In the “Configuration” menu of the selected IO-Link port, the setting of pin 2 and pin 4 on the selected port is displayed. Outputs can be set under certain conditions.

### 10.6.1 Input Data

Each user can observe the digital states of the inputs configured on the device.

IO OVERVIEW	
<b>Collapse all</b> <b>Expand all</b>	
▼ Input data	
Port X1 Pin 4 (Channel 01)	<b>Enabled</b> <input type="checkbox"/>
Port X2 Pin 4 (Channel 02)	<b>Enabled</b> <input type="checkbox"/>
Port X3 Pin 4 (Channel 03)	<b>Enabled</b> <input type="checkbox"/>
Port X4 Pin 4 (Channel 04)	<b>Enabled</b> <input type="checkbox"/>
▶ Allow forcing outputs	
▶ Output data	

## 10.6.2 Output Data

### Allow Outputs Setting

Users with Admin, Service and Maintenance rights can allow setting of outputs in this menu.

The right is only granted if the device is not in an active fieldbus connection with the control. The control has priority.

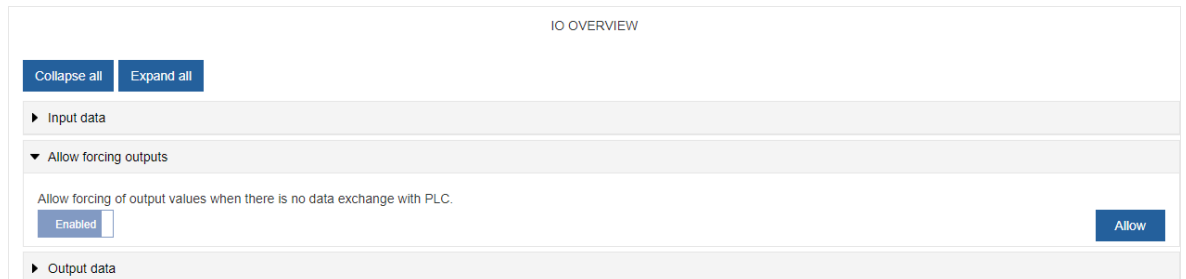

The screenshot shows the 'IO OVERVIEW' web interface. At the top, there are two buttons: 'Collapse all' and 'Expand all'. Below these, there are three expandable sections: 'Input data', 'Allow forcing outputs', and 'Output data'. The 'Allow forcing outputs' section is expanded, showing the text 'Allow forcing of output values when there is no data exchange with PLC.' and a toggle switch set to 'Enabled'. To the right of this section is a blue 'Allow' button.

### Setting of Output Data

Guest users are not allowed to set the outputs.

All other users (admin, operator, maintenance) are allowed to set the outputs.

As soon as the user (admin, operator, maintenance) logs out, the outputs go to "0".

As soon as a fieldbus is actively working with the device, the outputs go to "0" and then assume the status that they receive from the controller.

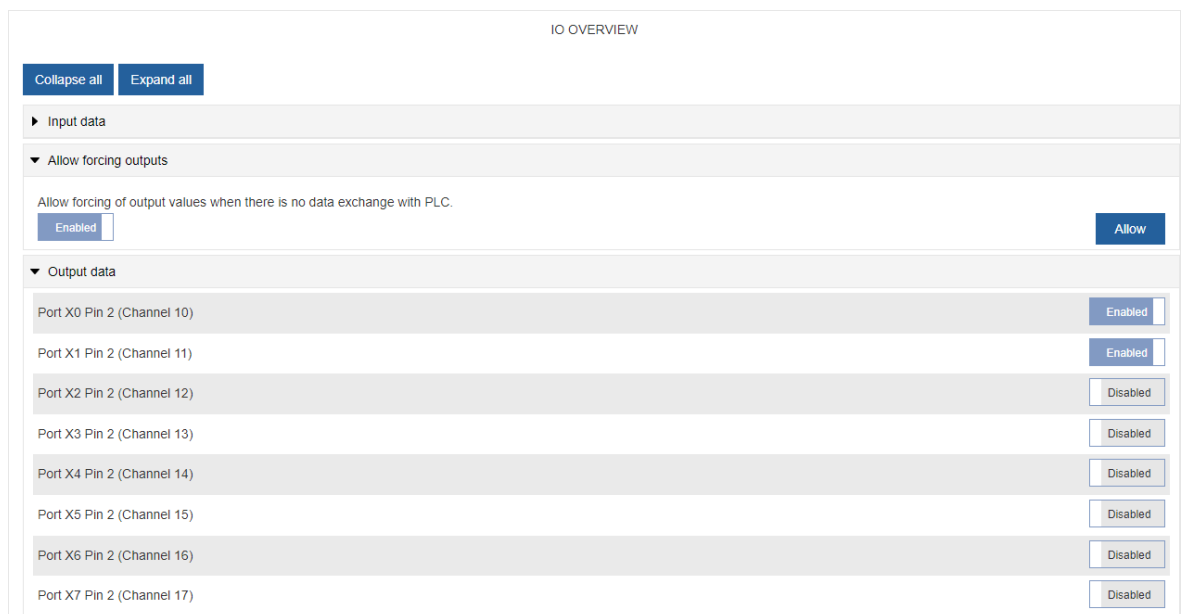

The screenshot shows the 'IO OVERVIEW' web interface with the 'Output data' section expanded. It lists eight output channels, each with a toggle switch: 'Port X0 Pin 2 (Channel 10)' (Enabled), 'Port X1 Pin 2 (Channel 11)' (Enabled), 'Port X2 Pin 2 (Channel 12)' (Disabled), 'Port X3 Pin 2 (Channel 13)' (Disabled), 'Port X4 Pin 2 (Channel 14)' (Disabled), 'Port X5 Pin 2 (Channel 15)' (Disabled), 'Port X6 Pin 2 (Channel 16)' (Disabled), and 'Port X7 Pin 2 (Channel 17)' (Disabled). A blue 'Allow' button is visible to the right of the 'Allow forcing outputs' section.

## 10.7 Settings / Maintenance

### 10.7.1 DEVICE CONFIGURATION Menu

In Profinet, the address is usually assigned by the control system using the DCP. Therefore, only the IP setting can be read in the web server.

The screenshot shows the Wenglor web interface. The top navigation bar includes the Wenglor logo and user information (English, Logged in as: Admin, About). The left sidebar lists various menu items, with 'Settings / Maintenance' highlighted. The main content area is divided into tabs: 'DEVICE CONFIGURATION', 'MAINTENANCE INFORMATION', 'FIRMWARE', and 'FACTORY RESET'. Under 'DEVICE CONFIGURATION', there are 'Collapse all' and 'Expand all' buttons. The 'Interface configuration status' section is expanded, showing a table with the following data:

Device IP address	192.168.100.1
Subnet mask	255.255.255.0
Gateway IP address	0.0.0.0

## 10.7.2 MAINTENANCE INFORMATION Menu

The maintenance information appears in the device in the menu item “Status” and submenu “Maintenance information”.

The screenshot shows the 'STATUS' menu in the Wenglor web interface. The 'MAINTENANCE INFORMATION' submenu is expanded, showing a table with the following data:

- Name	EP18P001-23
- Installation location	G4P1
- Description	IO-Link Master
- Last service date (yyyy-mm-dd)	2024-12-03
- Next service date (yyyy-mm-dd)	2025-12-03

Users with service, maintenance and admin rights can enter information about the device here.

The screenshot shows the 'MAINTENANCE INFORMATION' edit form in the Wenglor web interface. The form contains the following input fields and values:

Name	EP18P001-23
Installation location	G4P1
Installation date (yyyy-mm-dd)	2024-12-03
Contact information	
Description	IO-Link Master
Last service date (yyyy-mm-dd)	2024-12-03
Next service date (yyyy-mm-dd)	2025-12-03

An 'Apply' button is located at the bottom of the form.

## 10.7.3 FIRMWARE Menu

This menu item displays the data of the firmware running on the device.

Users with service, maintenance and admin rights can install new firmware on the device here, provided in ZIP folders. After successful loading, the device checks the firmware container and starts automatically with the new firmware version.

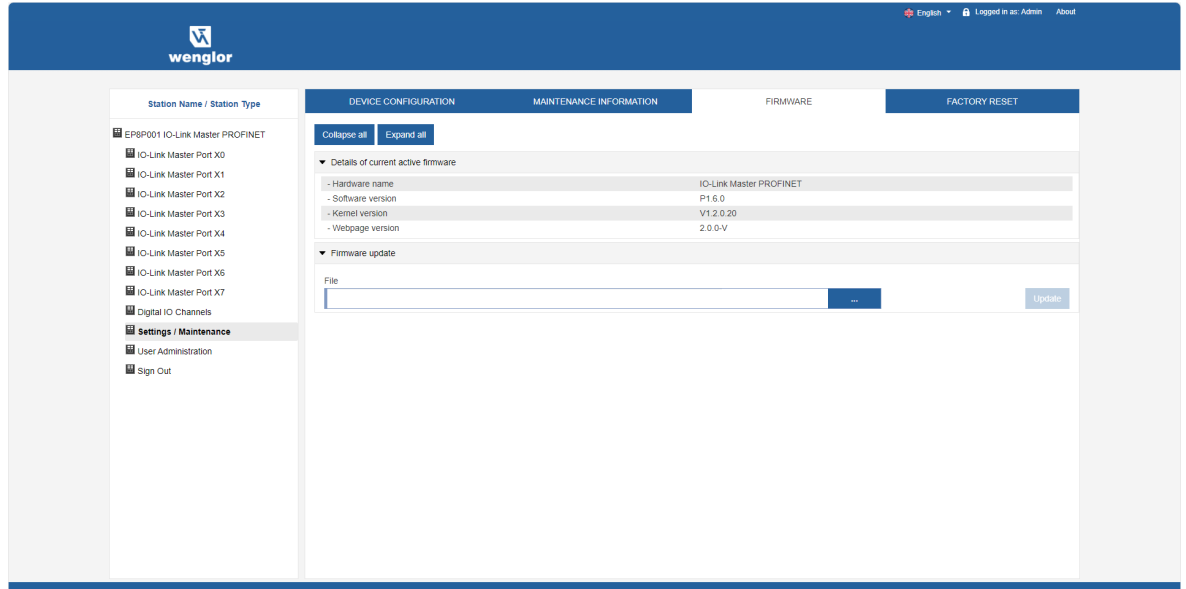

## 10.7.4 FACTORY RESET Menu

In this menu item, users with service, maintenance and admin rights can reset the entire device or individual sub-areas (device information, network, application).

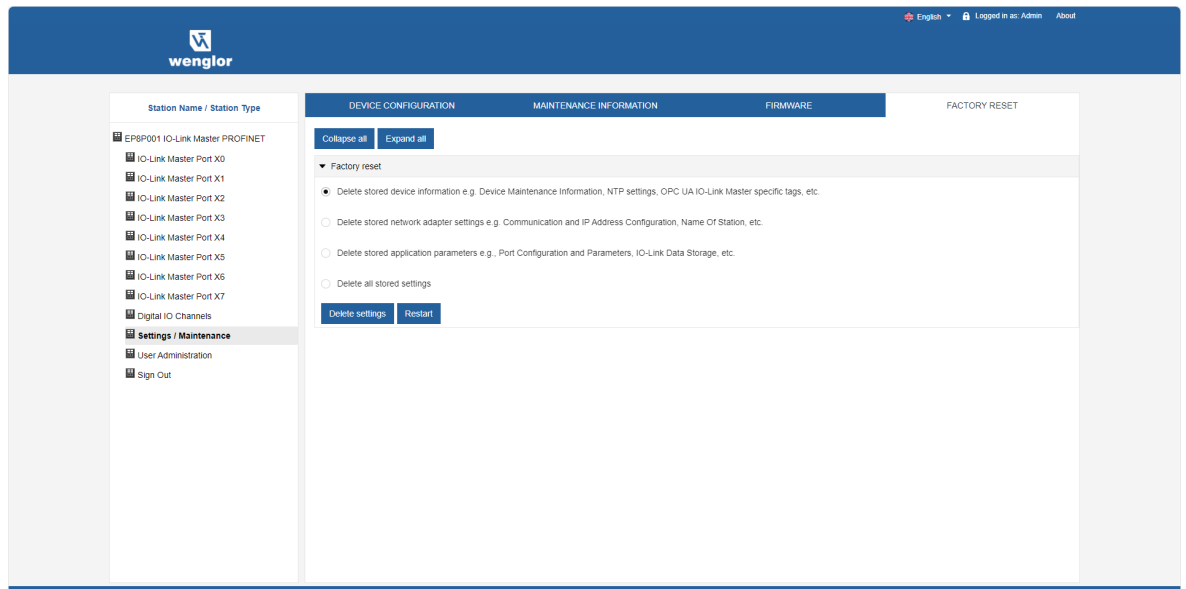

## 10.8 User Management

User administration can only be carried out with admin rights. Additional users with different user roles can be created here.

The administrator default password can be changed in the system with the fieldbus running from the controller.

Users log on and off in the system tree:

- Click on Logout.

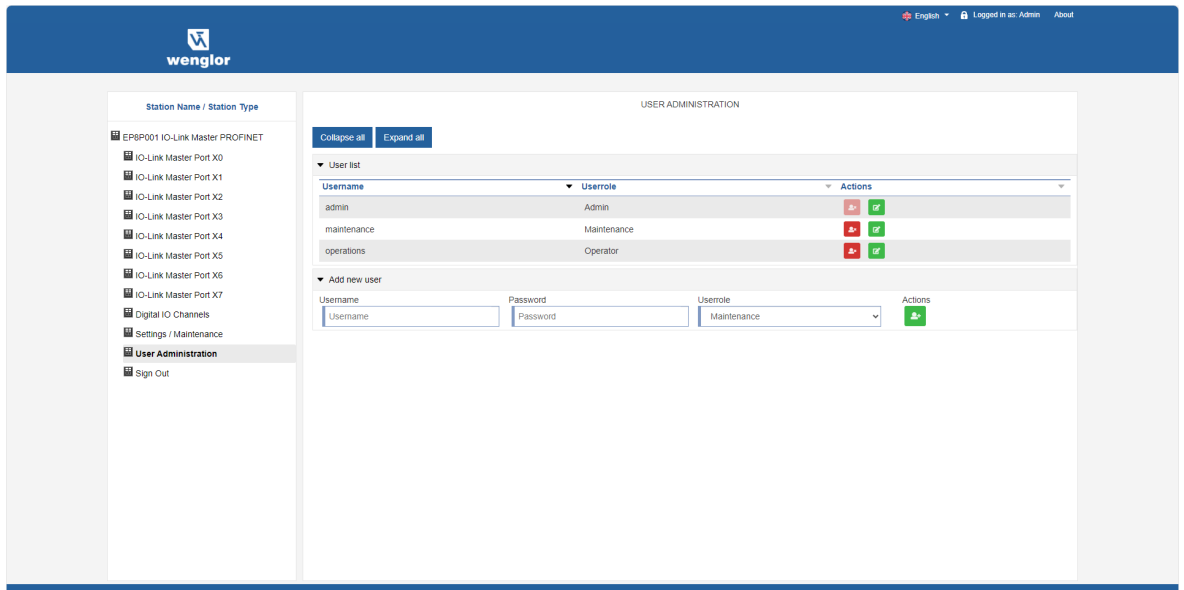

# 11 Maintenance Instructions



## NOTICE

This wenglor product is maintenance-free.

Cleaning and inspection of the plug connections at regular intervals are advisable.

Do not clean the product with solvents or cleaning agents that could damage the product.

The product must be protected against contamination during initial start-up.

---

## 12 Proper Disposal

wenglor sensoric GmbH does not accept the return of unusable or irreparable products. Respectively valid national waste disposal regulations apply to product disposal.

## 13 **Declarations of Conformity**

Declarations of conformity can be found on our website at [www.wenglor.com](http://www.wenglor.com) in the product's separate download area.