

Operating Instructions

EP8E001

IO-Link Master EtherNet/IP



EN



Table of Contents

1	General	5
1.1	Information Concerning these Instructions	5
1.2	Explanation of Symbols	5
1.3	Limitation of Liability	6
1.4	Copyrights	6
2	For Your Safety	7
2.1	General Safety Instructions	7
2.2	Use for Intended Purpose	8
3	Description	9
3.1	Device	9
3.1.1	Device Configuration	9
3.1.2	Pin Assignments	10
3.1.3	Display Units	11
4	Technical Data	12
4.1	Electrical data	12
4.2	Ambient Conditions	15
4.3	Protection	16
4.4	Mechanical Data	16
4.5	Conformity, Approvals	16
4.6	Used IP Ports	17
5	Installation	18
5.1	Prerequisites	18
5.2	Dimensions	18
5.3	Mounting Clearance	19
5.4	Installation of the Unit	19
5.5	Functional Earth	21
5.6	Addressing Cover	21
6	Installation	22
6.1	Installing the Unit Electrically	22
6.1.1	Adjusting the Rotary Switch	23
6.1.2	Sensors and Actuators	25
6.1.3	Connect EtherNet/IP Bus	27
6.1.4	Power Supply	27
6.2	Ensure Tightness (IP67)	28
7	Initial Start-Up	29
7.1	Reading In the EDS Files	30
7.2	Adding a Device to the Network	31
7.3	Initial Start-Up without EDS	34
7.3.1	Connection, Parameters and Properties	34
7.3.2	Connection Matrix	34
7.3.3	Assemblies	35
7.3.4	Configuration Values	36
8	Configuration and Parameterization	43
8.1	Configuration	43
8.2	Adjusting the Parameters	44
8.3	Requested Packet Interval (RPI) Configuration	45

8.4	Device Level Ring (DLR) Configuration.....	46
8.5	IO-Link Configuration.....	46
8.6	Industrial Internet of Things (IIoT).....	46
8.6.1	JSON.....	46
8.6.2	MQTT.....	49
8.6.3	OPC UA.....	50
9	Operation.....	65
9.1	LED Display.....	65
9.1.1	LED Assignment to Channel and Pin.....	65
9.1.2	* Flashing Behavior:.....	65
9.1.3	LED Display for Inputs and Outputs.....	66
9.1.4	LED Display MS and NS.....	67
9.1.5	LED Display LNK/ACT.....	69
9.1.6	LED Display Status.....	69
9.1.7	LED Display POWER US and UA.....	70
9.1.8	Advanced LED Display.....	71
9.2	Diagnostics.....	73
9.2.1	Diagnostic Structure in the Control System.....	73
9.2.2	Diagnostics in the Web Server.....	73
9.2.3	Diagnostic Value.....	74
9.3	Acyclic IO-Link Device Accesses.....	77
9.3.1	Reading an IO-Link Device Index.....	77
9.3.2	Writing an IO-Link Device Index.....	78
9.3.3	CIP Status Codes.....	79
10	Web Server.....	80
10.1	Start Web Server.....	80
10.2	Access and Login.....	80
10.3	Start Screen.....	81
10.4	Menu Bar.....	82
10.4.1	STATUS Menu.....	83
10.4.2	PARAMETERS Menu.....	85
10.4.3	DIAGNOSTICS.....	86
10.4.4	IODD CATALOG Menu.....	87
10.4.5	MAINTENANCE Menu.....	87
10.5	IO-Link Master Port.....	87
10.5.1	STATUS Menu.....	88
10.5.2	INFORMATION Menu.....	89
10.5.3	CONFIGURATION Menu.....	90
10.5.4	IO-LINK PARAMETERS Menu.....	91
10.5.5	PROCESS DATA Menu.....	91
10.6	Digital IO Channels / IO Overview.....	92
10.6.1	Input Data.....	92
10.6.2	Output Data.....	92
10.7	Settings / Maintenance.....	93
10.7.1	DEVICE CONFIGURATION Menu.....	93
10.7.2	MAINTENANCE INFORMATION Menu.....	94
10.7.3	FIRMWARE Menu.....	95
10.7.4	FACTORY RESET Menu.....	95
10.8	User Management.....	95
11	Appendix.....	97
11.1	Supported EtherNet/IP Objects.....	97
11.1.1	Standard Object Class.....	97
11.1.2	Vendor-Specific Objects.....	104
11.2	Explanation of the Process Data.....	106
11.2.1	Digital Input.....	106
11.2.2	DI Qualifier.....	106
11.2.3	DO Qualifier.....	106

11.2.4 System Status.....	107
11.2.5 IO-Link Port X Status.....	107
11.2.6 Diagnostic Buffer.....	107
11.2.7 Digital Output.....	108
12 Maintenance Instructions	109
13 Proper Disposal	110
14 Declarations of Conformity.....	111

1 General

1.1 Information Concerning these Instructions

- These instructions make it possible to use the product safely and efficiently.
- These instructions are an integral part of the product and must be kept on hand for the entire duration of its service life.
- Local accident prevention regulations and national work safety regulations must be complied with as well.
- The product is subject to further technical development, and thus the information contained in these operating instructions may also be subject to change. The current version can be found at www.wenglor.com in the product's separate download area.



INFORMATION

The operating instructions must be read carefully before using the product and must be kept on hand for later reference.

1.2 Explanation of Symbols

- Safety precautions and warnings are emphasized by means of symbols and signal words.
- Safe use of the product is only possible if these safety precautions and warnings are adhered to.

The safety precautions and warnings are laid out in accordance with the following principle:

SIGNAL WORD

Type and source of danger!

Possible consequences in the event that the hazard is disregarded.

→ Measures for averting the hazard.

The meanings of the signal words, as well as the scope of the associated hazards, are listed below:



! DANGER

This signal word indicates a hazard with a high degree of risk which, if not avoided, results in death or severe injury.



! WARNING

This signal word indicates a hazard with a medium degree of risk which, if not avoided, may result in death or severe injury.



! CAUTION

This signal word indicates a hazard with a low degree of risk which, if not avoided, may result in minor or moderate injury.



NOTICE

This signal word draws attention to a potentially hazardous situation which, if not avoided, may result in property damage.



INFORMATION

Information draws attention to useful tips and suggestions, as well as information on efficient, error-free use.

1.3 Limitation of Liability

- The product has been developed in consideration of the current state-of-the-art technology, as well as applicable standards and guidelines. Subject to change without notice.
- A valid declaration of conformity can be accessed at www.wenglor.com in the product's separate download area.
- wenglor sensoric elektronische Geräte GmbH (hereinafter referred to as "wenglor") excludes all liability in the event of:
 - Non-compliance with the instructions
 - Use of the product for purposes other than those intended.
 - Use by untrained personnel.
 - Use of unapproved spare parts.
 - Unapproved modification of products.
- These operating instructions do not include any guarantees from wenglor with regard to the described procedures or specific product characteristics.
- wenglor assumes no liability for printing errors or other inaccuracies contained in these operating instructions unless wenglor was verifiably aware of such errors at the point in time at which the operating instructions were prepared.

1.4 Copyrights

- The contents of these instructions are protected by copyright law.
- All rights are reserved by wenglor.
- Commercial reproduction or any other commercial use of the provided content and information, in particular graphics and images, is not permitted without previous written consent from wenglor.

2 For Your Safety

2.1 General Safety Instructions



DANGER

High electrical voltage in the machine/system.

Death or serious injury from electric shock.

→ Comply with the five safety rules of electrical engineering when working on the machine/equipment.

Protection of Persons and Property

According to DIN VDE 0105-100 – Operation of electrical systems – Part 100: General specifications

The Five Safety Rules

Protect against high voltage

1. Enable.
2. Secure against being switched on again.
3. Check that there is no voltage at all poles.
4. Ground and short-circuit.
5. Cover or cordon off adjacent live parts.

Specialist Personnel

Only qualified and safety-technically instructed personnel may install, commission and operate the device.

You are qualified if you meet the following conditions:

- You have suitable electrical training.
- You have been instructed by the machine operator in the operation of the system and the applicable safety regulations.
- You have access to the operating instructions and the manual.
- You are familiar with the safety standards of automation technology.
- You are familiar with the basic and technical standards applicable to the specific application.

Use of the Device

Observe all safety and accident prevention regulations during project planning, installation, initial startup, operation and testing of the device.

When using aggressive media, check the material resistance.



INFORMATION

Only qualified personnel from wenglor Sensoric GmbH may perform interventions in the hardware and software, with the exception of firmware updates.



INFORMATION

Only use a power supply unit that allows max. 60 V DC or 25 V AC in the event of a fault. It must comply with SELV or PELV.

Safety Measures of the Machine Operator

- Follow the instructions in this manual.
- Observe the test specifications in the operating instructions of all connected components.

2.2 Use for Intended Purpose

The EP8 family of devices are decentralized devices. They can be used in harsh industrial environments up to IP67 degree of protection.

The intended operation of the devices and the degree of protection IP67 is only guaranteed if open plugs and sockets are closed with locking screws.

Intended use also includes EMC-compliant electrical installation. The device is intended for use in industrial environments. When used in residential or mixed-use areas, radio interference may occur.

When using the device in residential or mixed-use areas, observe the applicable standards.

Foreseeable Misuse

- Do not modify the device structurally, technically or electrically.
- Do not use the device outside the areas described in this manual, the technical data and the operating instructions.
- Do not use the device as a safety-related device. It does not comply with the relevant standards. Safety functions of the system are not guaranteed!
- Switching the device outputs to the off state may not be used for safety requirements for the respective machine or system!
- Do not use the device outdoors or for permanent operation in liquids.
- Do not clean the device with a high-pressure cleaner.
- Do not use the device as a climbing aid.

Warranty and liability claims are forfeited if:

- the device is not used as intended,
- damage is due to failure to observe the manual and operating instructions,
- the personnel was/is not competent.

3 Description

3.1 Device

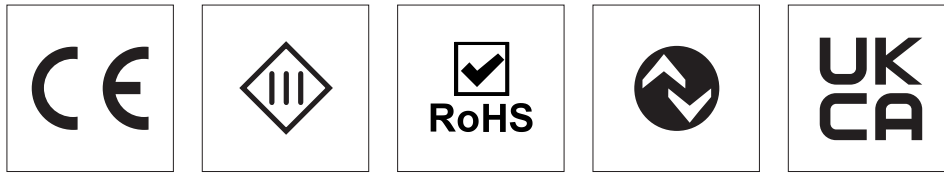

EtherNet/IP

3.1.1 Device Configuration

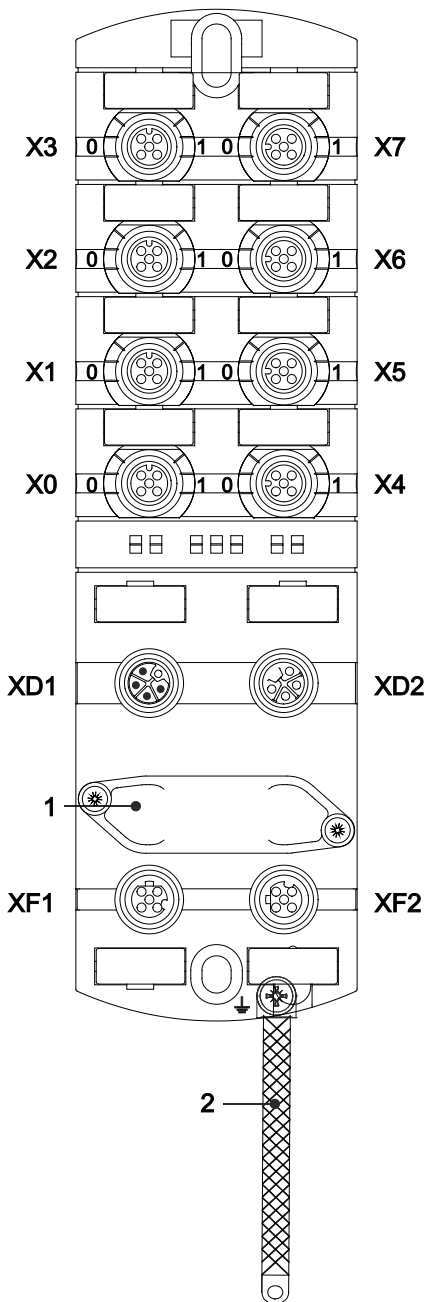

- X0 ... X7 Digital inputs and outputs or IO-Link
M12 A-coded
- 0 Channel corresponds to Pin 4
- 1 Channel corresponds to Pin 2
- Examples:
Channel 02 = Pin 4 Socket X2
Channel 16 = Pin 2 Socket X6

- XD1 Voltage supply POWER IN,
M12 L-coded, 5-pin
- XD2 Voltage supply POWER OUT,
M12 L-coded 5-pin

- 1 Rotary switch

- XF1 EtherNet/IP Port 1, M12 D-coded
- XF2 EtherNet/IP Port 2, M12 D-coded

- 2 Ground strap for functional earth

3.1.2 Pin Assignments

M12 Socket, A-Coded

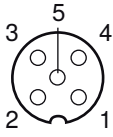
X0...X7		
	Pin 1	24 V DC
	Pin 2	DI/DO
	Pin 3	0 V
	Pin 4	DI/DO/IO-Link
	Pin 5	0 V

M12 Plug/Socket, L-Coded

POWER IN/OUT

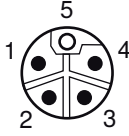
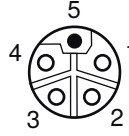
XD1		XD2	
	Pin 1	24 V DC	
	Pin 2	0 V	
	Pin 3	0 V	
	Pin 4	24 V DC	
	Pin 5	±	

M12 Socket, D-Coded

Port 1 / Port 2

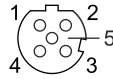
XF1 / XF2		
	Pin 1	TD +
	Pin 2	RD +
	Pin 3	TD -
	Pin 4	RD -
	Pin 5	Unused

3.1.3 Display Units

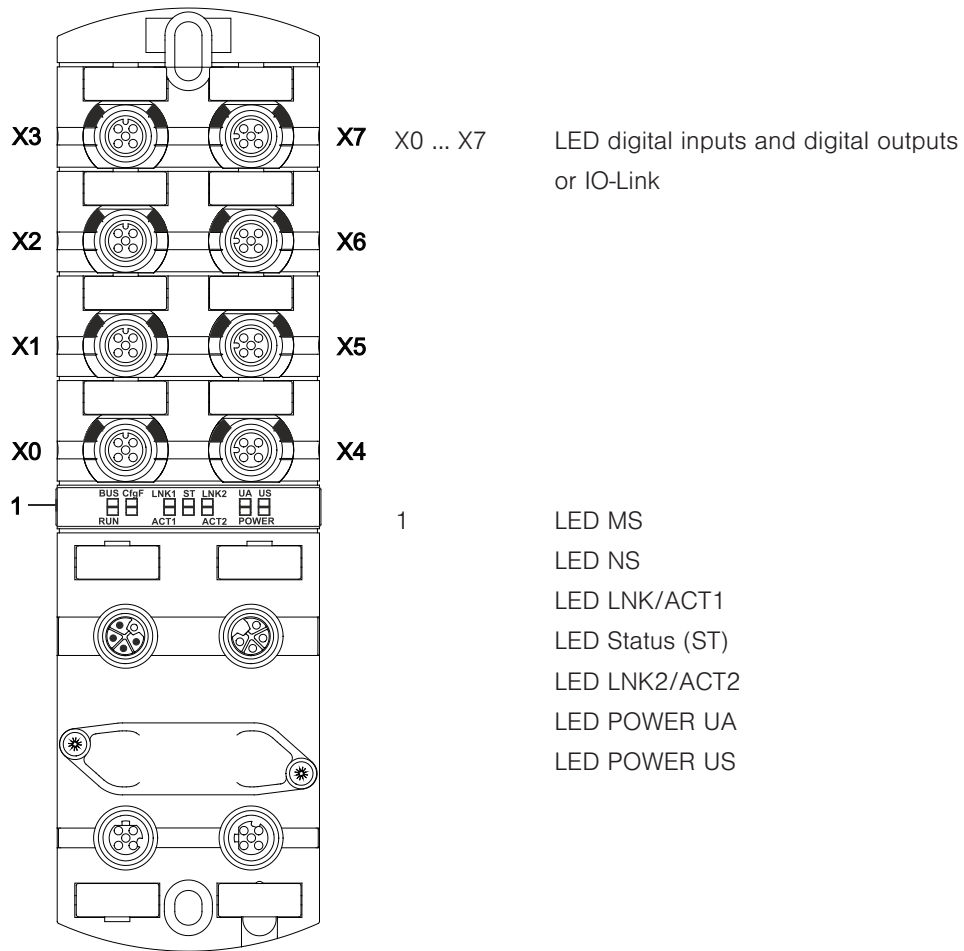

INFORMATION

For more information on the behavior of the LEDs, see section “LED Display [▶ 65]”

4 Technical Data

4.1 Electrical data

Bus Data		
Bus protocol		EtherNet/IP
Ethernet		10/100 Mbit/s
Addressing		BOOTP, DHCP, WebUI, rotary encoder
Connection types		Exclusive Owner, Listen Only, Input Only
Device Level Ring (DLR)		Beacon based
Connection		M12, 4-pin, D-coded

OPC UA Server		
OPC UA Server	According to "IO-Link Companion Specification"	Yes
Transport		UA TCP, UA Secure Conversation, UA Binary Encoding
Server profile		Micro embedded device
Protocol		OPC UA TCP
User access	Read access only Read and write access	Anonymous Username/password
Number of sessions		2
Number of subscriptions per session		2
Number of "Monitored Items" per session		20
Minimum publication interval		100 ms
Maximum number of sessions/clients		5
Data coding		UA binary
Energy monitoring	Current and voltage	Yes
Temperature monitoring		Yes

MQTT client		
MQTT		Client
Client services		Publish
Protocols	Via TCP	MQTT
Topic size	Individually per MQTT publication and Common topic prefix of the associated MQTT connection	≤ 256 bytes ≤ 256 bytes
Topics		- Printable UTF-8 string - ZERO-terminated - Multi-byte encoding (MBCS)

MQTT client		
		- Payload: JSON
Will Topic		≤ 256 bytes
Quality of service		QoS 0, QoS 1 and QoS 2
IP standard		IPv4
Port	1883 (standard)	MQTT unencrypted
MQTT standard		V3.1.1
JSON, MQTT	JSON integration for IO-Link V1.0.0	Yes, via REST API and MQTT
Energy monitoring	Current and voltage	Yes
Temperature monitoring		Yes
Restriction		The service "Subscribe" not supported

Web server		
HTTP		HTTP/1.1
Port		80
Connections	Via TCP	≤8 simultaneous connections. A connection is being edited.
JavaScript		Required
HTTPS		Not supported

IO-Link		
Operating voltage IO-Link devices		24 V DC
Voltage range IO-Link devices		20...30V DC
Transmission speed		COM1 / COM2 / COM3
Standardized Master Interface (SMI)		See IO-Link specification
Transmission speed detection		Automatic

Supply Power		
Operating voltage US		24 V DC
Voltage range US		18...30 V DC
	When using IO-Link	20.3...30 V DC
Operating voltage UA		24 V DC
Voltage range UA		18...30 V DC
Sensor current US	≤ 40 °C (see derating)	≤ 16 A
Actuator current UA	≤ 40 °C (see derating)	≤ 16 A
Current consumption	In idle	≤ 0.18 A
Reverse polarity protection for US and UA		Yes
Reverse polarity protected		Yes
Connection		M12, 5-pin, L-coded
Cable cross section	Current per supply ≤12 A	≥ 1.5 mm ²
	Current per supply >12 A	≥ 2.5 mm ²

Input (DI)		
Sensor power supply	Per port, $\leq 40\text{ }^{\circ}\text{C}$ (see derating)	$\leq 2\text{ A}$ load Automatic start
Total current sensor supplies	$\leq 40\text{ }^{\circ}\text{C}$ (see derating)	$\leq 10\text{ A}$
Filter time		0 ... 15 ms + t_{cycle} , configurable
Delay time at signal change		2 ... 5 ms
Input characteristics	EN 61131-2	Type 1 + Type 3
Short-circuit protection sensor supply		MOSFET with current measurement
Connection		M12, 5-pin, A coded
Cable cross-section M12		$\leq 0.75\text{ mm}^2$
Cable Length		$\leq 30\text{ m}$
Total current	Per port	$\leq 4\text{ A}$

Output (DO)		
Output current DO (UA)	Per pin, $\leq 40\text{ }^{\circ}\text{C}$ (see derating)	$\leq 2\text{ A}$
Total current outputs	$\leq 40\text{ }^{\circ}\text{C}$ (see derating)	$\leq 10\text{ A}$
Switching frequency		$\leq 50\text{ Hz}$
Actuator short-circuit protection		MOSFET with current measurement
Connection		M12, 5-pin, A coded
Cable cross-section M12		$\leq 0.75\text{ mm}^2$
Cable Length		$\leq 30\text{ m}$
Total current	Per port	$\leq 4\text{ A}$

Derating

Sensor Current US/Actuator Current UA

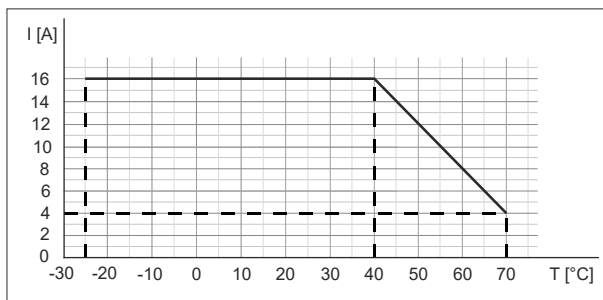

Derating Total Current Sensor Supplies/Total Current Outputs

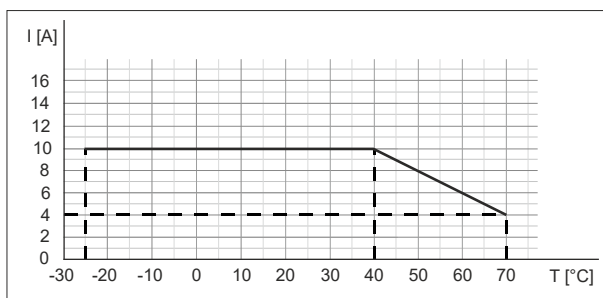

Derating Current per Sensor Supply/Output

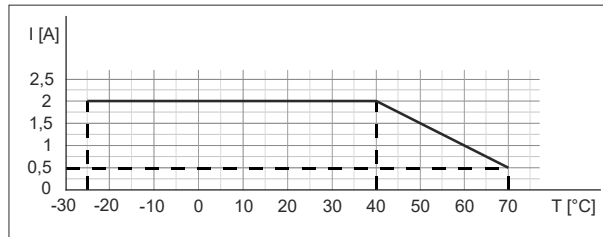

4.2 Ambient Conditions

Climatic Conditions		
Ambient temperature		-40 °C ... +70 °C
Storage temperature	Provide for acclimatization for initial start-up	-40 °C ... +85 °C
Transport temperature	Provide for acclimatization for initial start-up	-40 °C ... +85 °C
Relative humidity		≤ 95%
Installation altitude	Above normal height	≤ 3,000 m

Mechanical Characteristics		
Vibration testing	EN 60068 Part 2–6	10 ... 58 Hz, oscillation range 0.35 mm, 58 ... 150 Hz; 20 g
Shock test	EN 60068 Part 2–27	50 g, duration 11 ms

Electric Safety		
Degree of protection	EN 60529	IP67
Protection class	Using a SELV or PELV power supply	III
Pollution degree		2

EMC Interference Emission		
Radio interference field strength housing	EN 55016-2-3	Compliant

EMC Interference Immunity		
Electrostatic discharge (ESD)	EN 61000-4-2	Compliant
High frequency electrical fields	EN 61000-4-3	Compliant
Fast transients burst	EN 61000-4-4	Compliant
Surge voltages	EN 61000-4-5	Compliant
Conducted HF	EN 61000-4-6	Compliant
Voltage dips	EN 61000-4-11	Compliant

4.3 Protection

Equipment Protection		
Overvoltage protection		Yes
Overload protection device supply	To be ensured by load circuit monitoring	Yes
Reverse polarity protection device supply		Yes
Short-circuit protection sensor supply		Electronic
Short-circuit protection output		Electronic
Protective circuit input	Internal	Suppressor diode

4.4 Mechanical Data

Material Data		
Housing material		Plastic

Mounting Data		
Weight	Net	470 g
Dimensions	L × W × H	225.4 × 63 × 36 mm

4.5 Conformity, Approvals

Conformity, Approvals		
Product standard	EN 61131-2 Programmable logic controllers part 2	Compliant
CE	2014/30/EU 2011/65/EU	Compliant
UKCA		Compliant
EMC	2014/30/EU	Compliant
REACH	No. 1907/2006	E201820
WEEE	2012/19/EU	Compliant
UL		E201820
RoHS	2011/65/EU & 2015/863	Exception 6c&7a
China RoHS	SJ/T 11364-2014	25 EPUP

Hazardous substance (有害物質)							
	Part Name 零件名稱	Lead (Pb) 鉛	Mercury (Hg) 汞	Cadmium (Cd) 鎘	Hexavalent Chromium (Cr (VI)) 六价铬	Polybrominated biphenyls (PBB) 多溴联苯	Polybrominated diphenyl ethers (PBDE) 多溴联苯醚
		Component part PCB ^{1 2} 组件部分 印刷电路板	X	0	0	0	0
	Connection Terminal / Screws / Housing ³ 接线端子 / 拧 / 外壳	X	0	0	0	0	0
<p>O : Indicates that the content of the harmful substance in all homogeneous materials of the component part is below the limit defined in GB/T 26572. O : 表明該有害物質在組成部分的所有均質材料的含量低於按GB/ T26572定義的限制。</p> <p>X: Indicates that the content of the harmful substance in at least one homogeneous material of the component part exceeds the limit defined in GB/T 26572. X: 表示該有害物質在組成部分中的至少一個均質材料的含量超過按GB / T26572定義的限制。</p>							

4.6 Used IP Ports

Port	
UDP port 44818:	Encapsulation messages based on UDP
UDP port 2222:	Implicit messaging (10 messaging)
UDP port 68	DHCP client
TCP port 44818	Encapsulation messages based on TCP. Explicit messaging
TCP port 80	Integrated web server
TCP port 4840	Integrated OPC UA server. Port can be re-configured at runtime: netPROXY Object "OPC UA Server - Component Configuration"



INFORMATION

There is no fixed or configurable port for the MQTT client. If MQTT client is activated, it is assigned to the next free port of the IP stack.

5 Installation

5.1 Prerequisites

Prerequisites for installation:

- Flat mounting surface for mechanically stress-free mounting.
- Provide suitable grounding.
- Suitable installation location with regard to vibration and shock load, temperature and humidity (see section 4 "Technical Data").
- Protected to prevent the connection cables from being torn off by personnel or equipment.

5.2 Dimensions

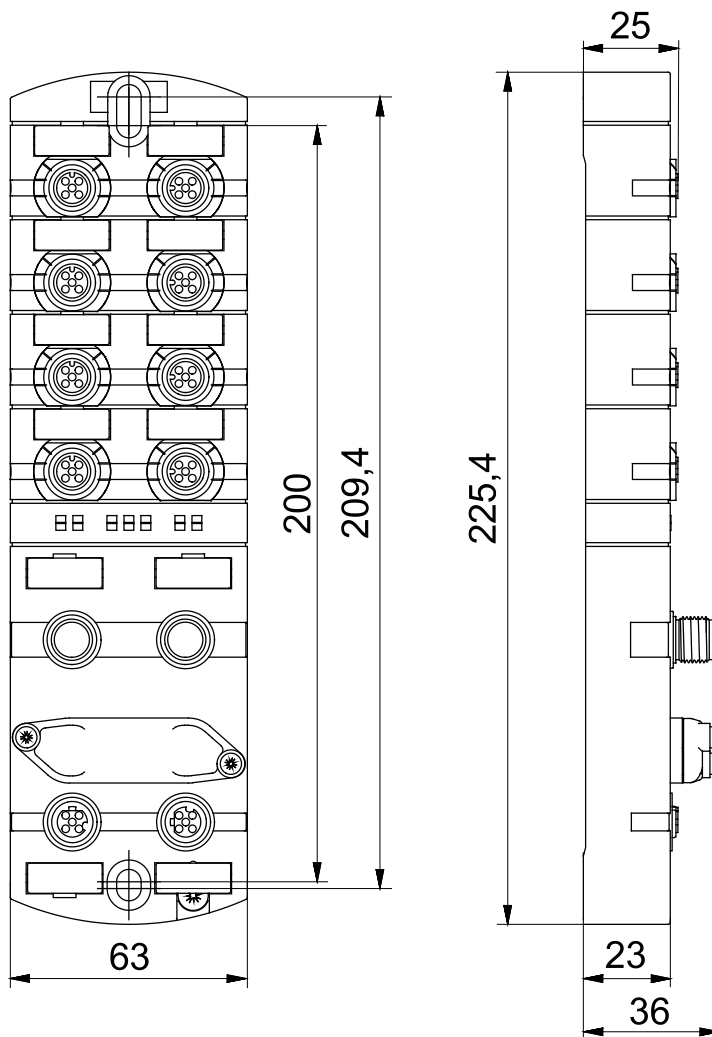

Dimensions in mm (1 mm = 0,03937 Inch)

5.3 Mounting Clearance

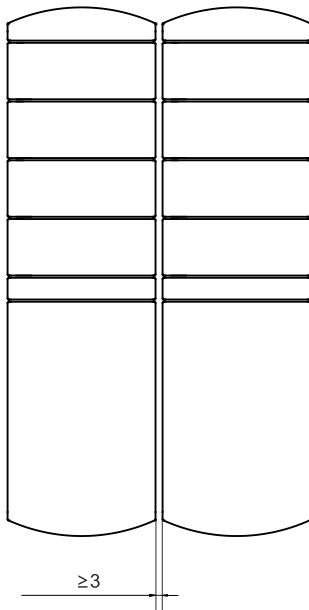

Distance in mm



INFORMATION

For proper installation and improved heat dissipation, we recommend maintaining a minimum distance of 3 mm when mounting the IO-Link Master.



INFORMATION

A minimum distance of 50 mm must be maintained when using angled plugs.

5.4 Installation of the Unit



NOTICE

Material damage due to incorrect installation.

The mounting screws and tightening torques depend on the subsurface of the installation site.

1. Use mounting screws according to the condition of the mounting surface.
2. Tighten the screws carefully. The specified tightening torques must be observed.



NOTICE

Material damage due to misuse.

Do not use the equipment as a climbing aid. Misuse may cause the devices to tear off or otherwise be damaged.

- Mount the devices in such a way that they cannot be used as climbing aids.

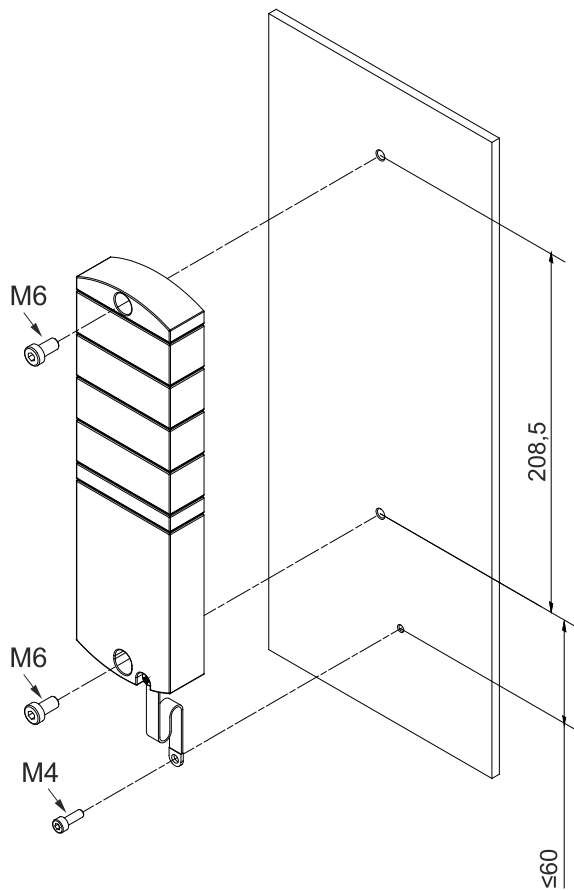

Secure the device. Dimensions in mm (similar to figure)

M6: 3 Nm torque

M4: 1.2 Nm torque

Mount the device in the specified order:

1. Slightly tighten the second M4 screw.
2. Align the housing.
3. Slightly tighten the bottom M4 screw.
4. Tighten the M4 screws according to the torque.
5. Ground the device: Fasten ground strap (Functional Earth ► 21]).



INFORMATION

The mounting screws and nuts are not included in the scope of delivery.

5.5 Functional Earth



INFORMATION

Note

Fasten the ground strap with a conductive screw.

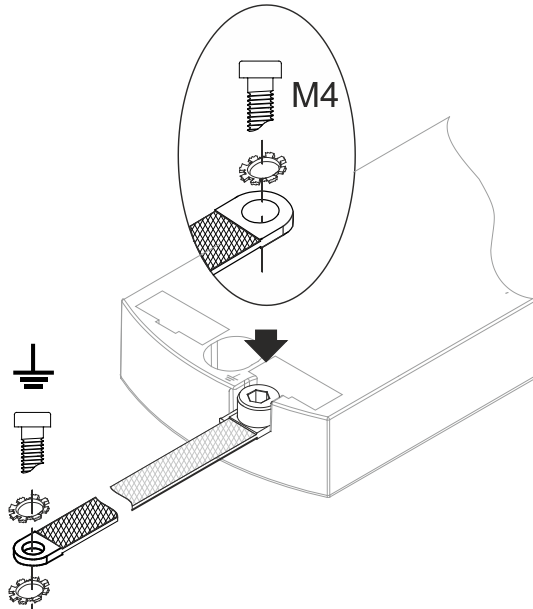

M4 tightening torque 1.2 Nm

5.6 Addressing Cover

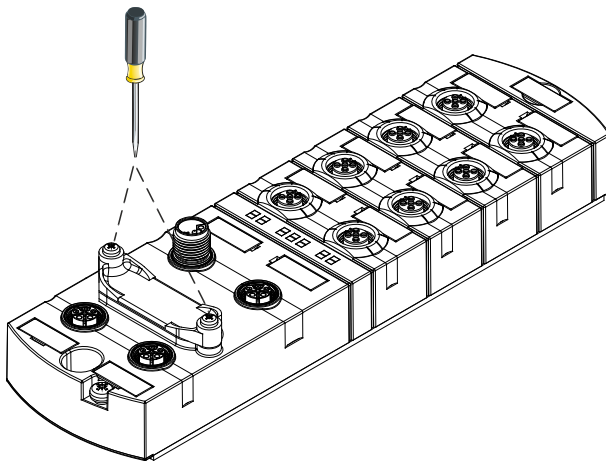

Attaching the addressing cover

M3 tightening torque 0.8 Nm



INFORMATION

Information on setting the rotary switches can be found in section [Adjusting the Rotary Switch](#) [► 23]

6 Installation

6.1 Installing the Unit Electrically



DANGER

High electrical voltage in the machine/system.

Death or serious injury from electric shock.

→ Comply with the five safety rules of electrical engineering when working on the machine/equipment.

Protection of Persons and Property



WARNING

Risk of fire due to short circuit.

Supply lines and/or devices damaged by a short circuit can overheat and cause fires!

→ Provide intelligent current monitoring or fuse. The fuse must be rated for max. 9 A.



CAUTION

Loss of function due to improper installation.

Failure to observe this may result in damage to property and personal injury.

→ Only install cables and accessories that comply with applicable safety and electromagnetic compatibility requirements and regulations, and if applicable correspond with any telecommunication terminal devices and their specifications.



CAUTION

Hot interface.

Slight bodily injury due to contact with the surface and damage to the equipment.

1. Wear suitable heat-resistant gloves.
2. Only use thermally suitable connection cables.



NOTICE

Damage to the machine/system due to improper switching on of the voltage sources.

When switching on the device with separate actuator and sensor, the function of the digital inputs and outputs is not guaranteed.

→ Always switch on the voltage sources in this order:

1. Switch on sensor voltage.
2. Switch on the actuator voltage.



INFORMATION

Only use a power supply unit that allows max. 60 V DC or 25 V AC in the event of a fault. It must comply with SELV or PELV.

6.1.1 Adjusting the Rotary Switch



INFORMATION

Factory default setting: The rotary switches are set to 000, DHCP activated.



INFORMATION

Each participant must have a clear and unique IP address in the network.

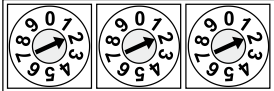
x 100 x 10 x 1	Address range 1 ... 999
	x1 rotary switch (one) x10 rotary switch (tens) x100 rotary switch (hundreds)

Position/Range	Web server	JSON	OPC UA	MQTT	Description	
0	_**	_**	_**	_**	Out of the box: DHCP	Previously saved interface configuration: Saved configuration is applied.
1 ... 254	_**	_**	_**	_**	Last Octet	Set the fourth octet of the IP address with the rotary switch value. Default: 192.168.1.xxx
255	_**	_**	_**	_**	Static IP address	The last saved IP address is active.
256 ... 910	_**	_**	_**	_**	Reserved**	
911	Deactivated	Deactivated	Deactivated	Deactivated	Secure mode	Fieldbus communication in normal operation
912	_**	Deactivated	Deactivated	Deactivated	IloT mode deactivated	
913	Deactivated	Deactivated			Web server and JSON deactivated	
914	Activated	Activated	Activated	Activated	Activates all IloT protocols and the web server.	
915-978	_**	_**	_**	_**	Reserved*	

Position/ Range	Web server	JSON	OPC UA	MQTT	Description
979	Activated	Activated	Deactivated	Deacti- vated	Default settings reset Procedure only for this rotary switch position: 1 Disconnect the unit from the voltage supply. 2 Set switch position 979. 3 Connect the power supply. 4 Wait until reset is complete. • ST LED flashes green: Device carries out reset. • ST LED lights up green: Reset is com- plete. ST LED display, see 9.1 “LED display” 5 Disconnect the power supply. 6 Switch position to 000 or another de- sired position. 7 Connect the power supply.
980-999	_*	_*	_*	_*	Reserved*



INFORMATION

* Note

Reserved switch positions have no fieldbus communication, see LED Display [▶ 65]



INFORMATION

** Note

The last protocol setting is retained.

Service Setting

The switch positions 911, 912 and 913 switch off the services of the device marked in the “Set Address” matrix. In these switch positions, the device starts normally with the previously set address configuration and has no function restrictions, except for the services deactivated by the switch position. The services deactivated as a result could not be activated again by other means, e.g. the configuration data of the control system.

Switch position 914 reactivates all services. Here too, the function of the device is not restricted.

1. Connect the power supply.
2. Disconnect the power supply.
3. Set original address.



INFORMATION

The saved default IP address is 192.168.1.6.



INFORMATION

The IP address parameters are saved for all switch settings. This must be observed in particular when the switch is in position 0.

Setting the Address

1. Disconnect the device power supply.
2. Remove the addressing cover.
3. Set a unique address.
4. Mount the addressing cover.
5. Connect the power supply.

The tightening torques can be found in section Addressing Cover [► 21]

6.1.2 Sensors and Actuators

Connect the M12 Socket

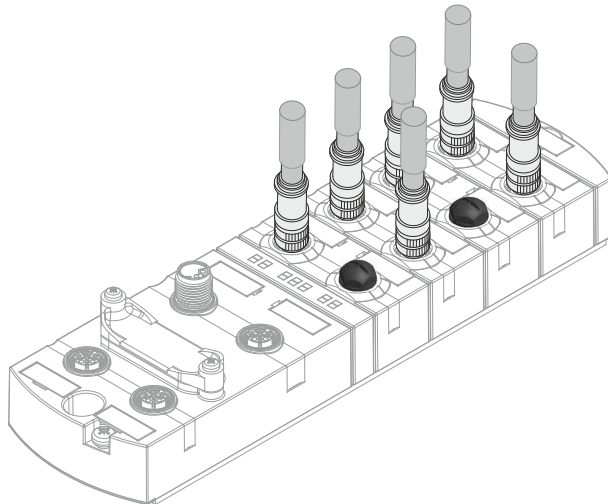
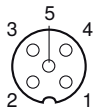

Example connection M12 inputs and outputs

Tightening torque 0.6 Nm

The pin assignment of the slots can be found in section “Pin Assignments [► 10]”



INFORMATION

Feeding in an external ground via the M12 sockets can lead to errors.

→ Do not feed any external ground into the device via the M12 sockets.



INFORMATION

The cable length of the sensor and actuator cables is limited to 30 m.

Sensor Power Supply

- Sensors can be supplied with power via **pin 1** (24 V) and **pin 3** (0 V) at the M12 sockets.
- The maximum permissible current for supplying the sensors is **2 A** per M12 socket.
- In the event of an overcurrent or short circuit, the connected wire or sensor must **be removed** from the M12 socket.

Status of IO-Link Communication

The device supports IO-Link communication at the following speeds:

- 4,800 baud (COM 1)
- 38,400 baud (COM 2)
- 230,400 baud (COM 3)



INFORMATION

The device automatically selects the correct transmission speed for the IO-Link device.



INFORMATION

The cable length for IO-Link connection is limited to max. 20 m.

6.1.3 Connect EtherNet/IP Bus

Connect the M12 Socket

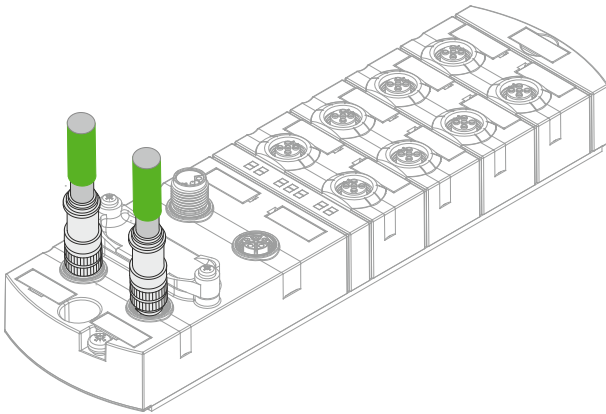
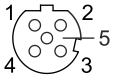

Example connection M12 BUS

Tightening torque 0.6 Nm

The pin assignment of the slots can be found in section “Pin Assignments [▶ 10]”

6.1.4 Power Supply

Connect the M12 Plug POWER IN

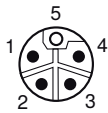

Connect M12 Socket POWER OUT

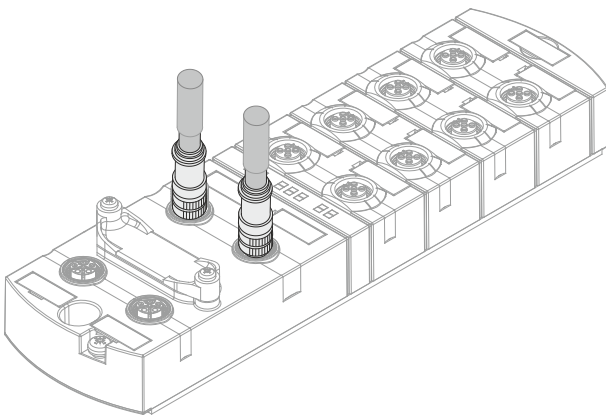
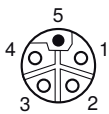

Example connection M12 POWER

Tightening torque 0.6 Nm

The pin assignment of the slots can be found in section “Pin Assignments [▶ 10]”

6.2 Ensure Tightness (IP67)



⚠ CAUTION

Leaky housing

Personal injury and material damage due to the ingress of conductive liquids in the event of device failure.

→ Seal unused plugs and sockets.

Connection Lines

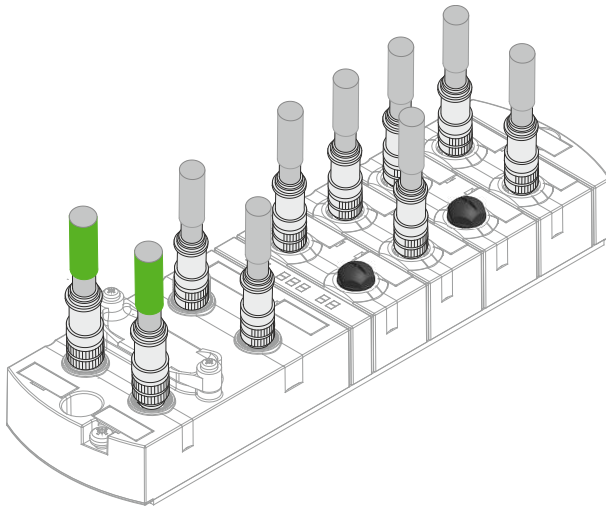

Connection lines

Tightening torque 0.6 Nm

7 Initial Start-Up



WARNING

Danger of burns!

It is forbidden to loosen or make electrical connections during operation. Failure to observe this rule results in a risk of arcing, which can cause burns.

→ Switch off the power supply to the unit



CAUTION

Uncontrolled processes

Property damage and personal injury due to incorrectly performed initial start-up phases (e.g. initial commissioning, re-commissioning and in the event of changes to the configuration).

→ Always perform initial start-up in this order:

1. Switch on the device.
2. Inspection and approval of the system by an expert.
3. Start up.



CAUTION

Malfunctions in the residential area

Equipment of EMC class A may cause interference in residential areas.

→ The operator must take appropriate measures

7.1 Reading In the EDS Files

Tool Used

This section uses the Studio5000 Logix Designer from Rockwell Automation Deutschland as an example to show how a device is designed and parameterized.

Reading In the EDS Files

Install the EDS files or the device description file.

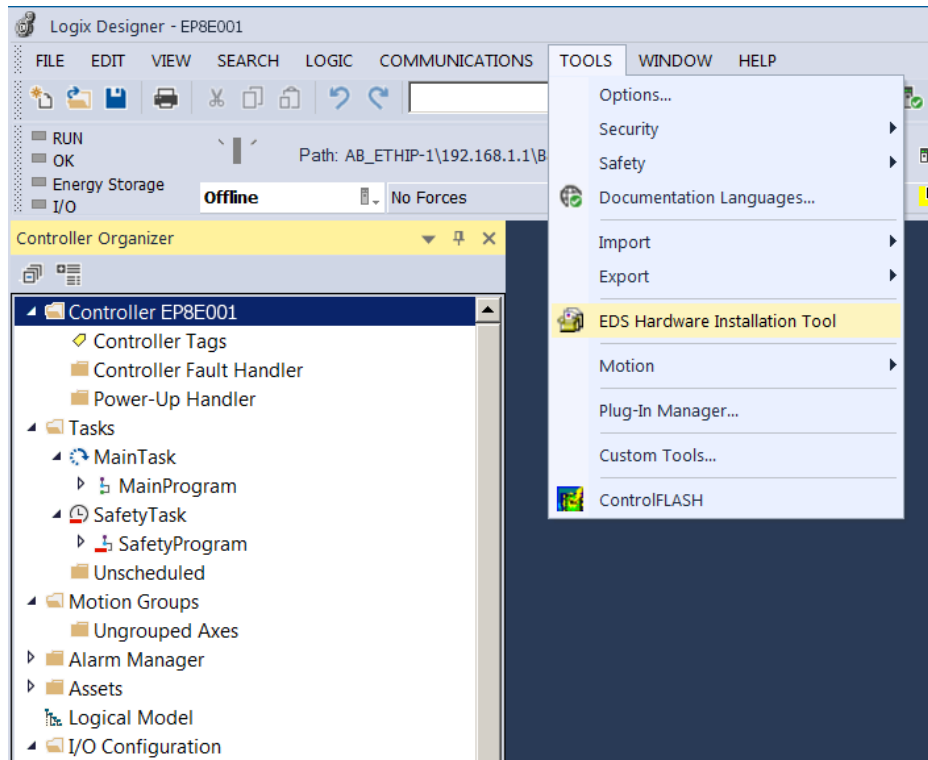

In the project menu | Tools

- Click on EDS Hardware Installation Tool.

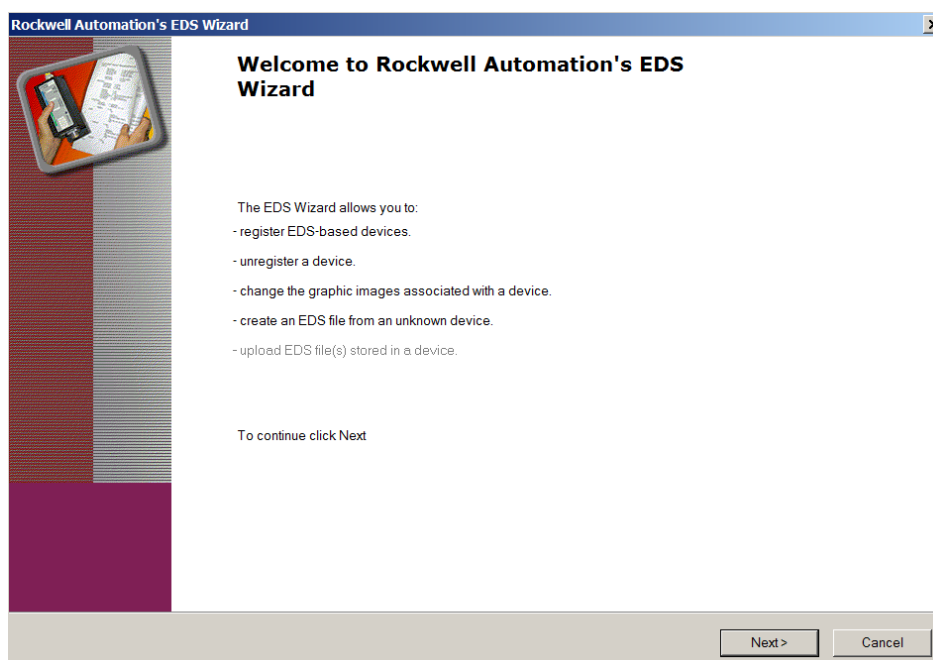

- Click Next and follow the instructions in the dialog box.
- Finish the installation of the EDS files. Now the devices can be selected and added to the network



INFORMATION

The EDS file is stored on the wenglor website under the item number of the device.

7.2 Adding a Device to the Network

Add New Modules

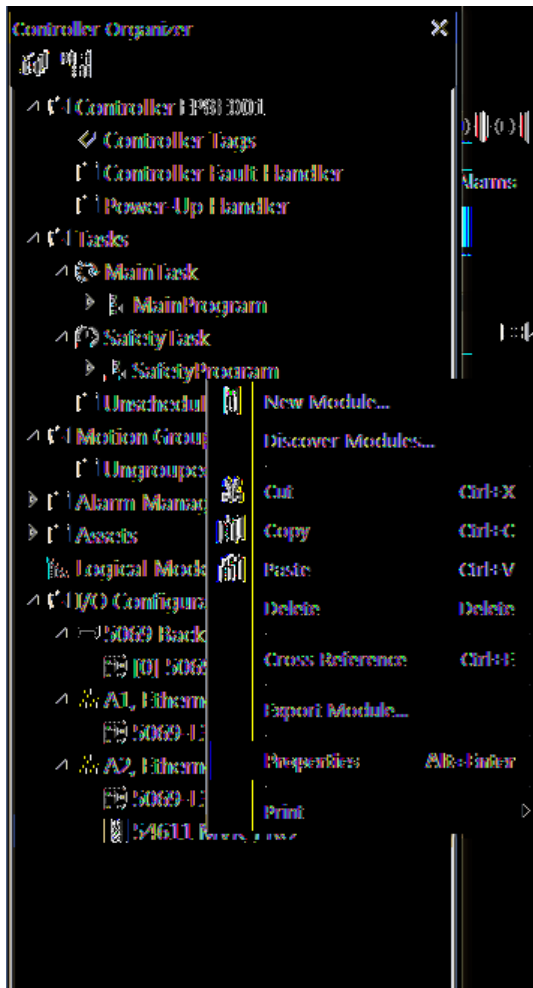

In the Controller Organizer | Ethernet

- Click New Module.

The following dialog box displays devices that

- have been previously registered with an EDS or
- were supplied with the engineering software installation.

Alternative Module Selection

Alternatively, the dialog window can also be called up via the menu bar via File/New Component/Module.

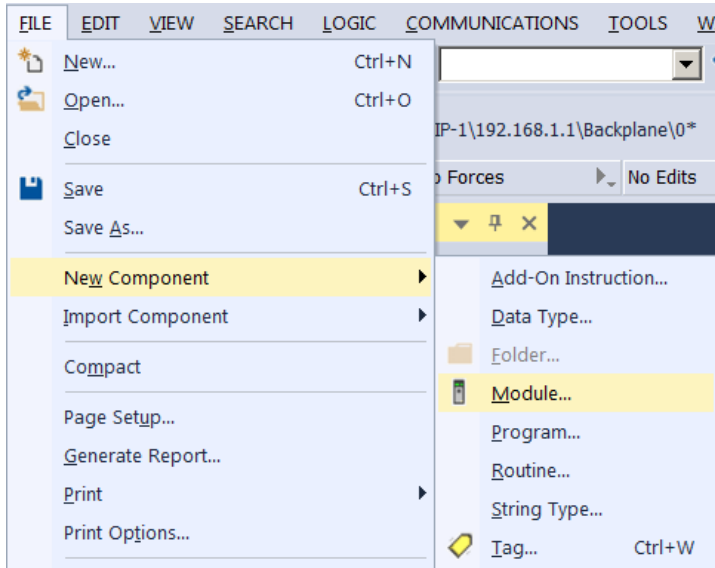

Search for the Device

In the input screen, search for the device to be added to the network.

- Use terms as a search term that describe the desired device, e.g. product number, product name or manufacturer.
- Use filters from the dialog box.

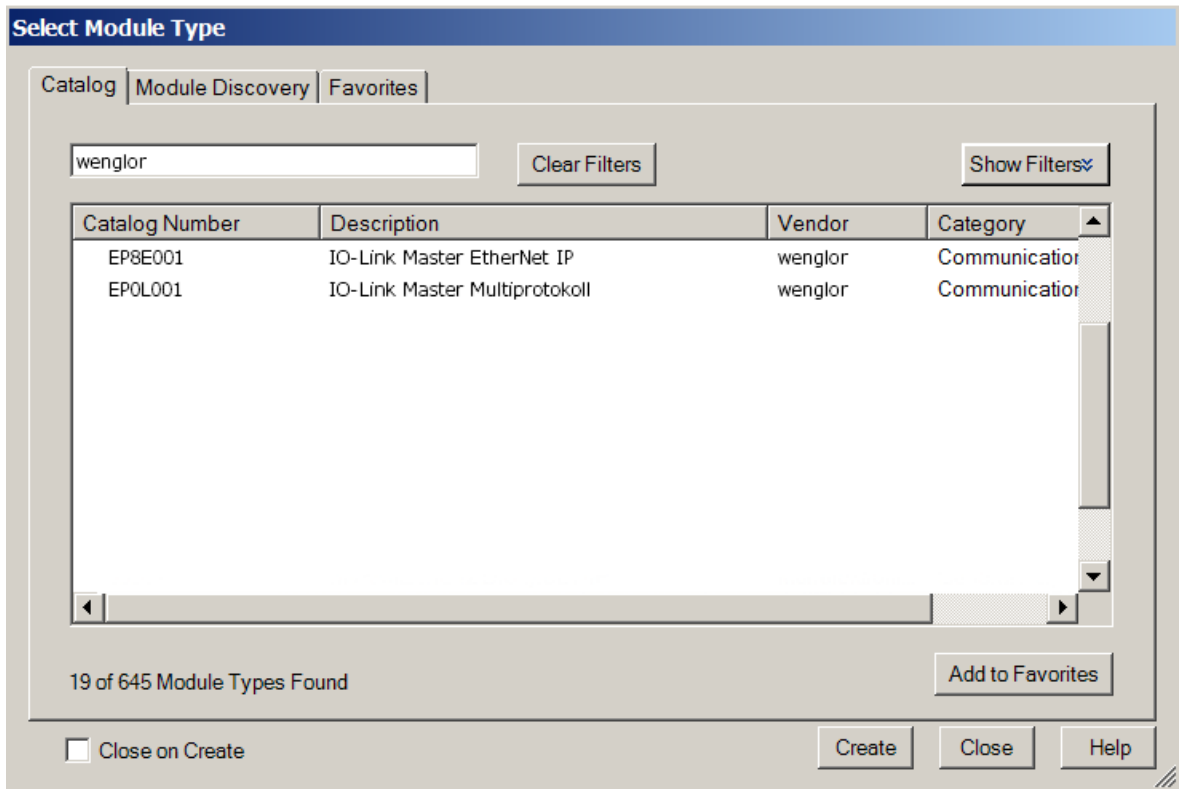

- Mark the device.
- Double-click on Create.

General Settings

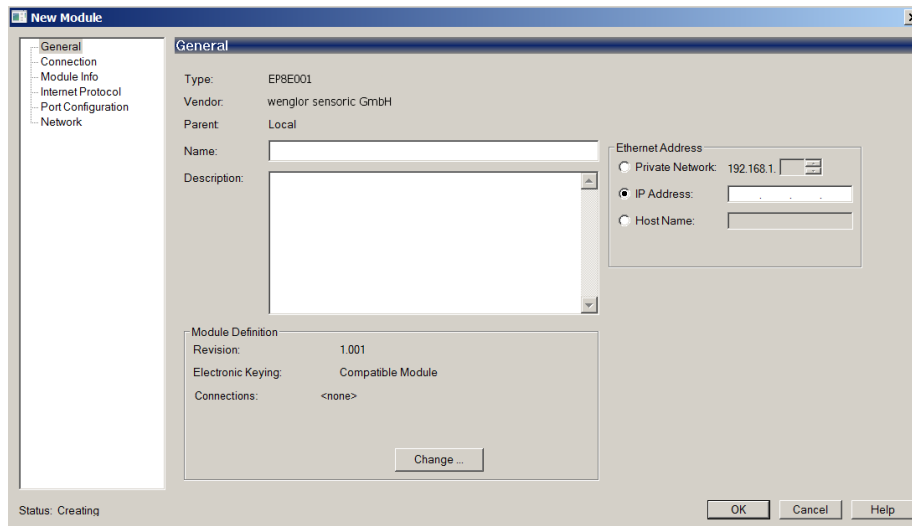

In New Module | General

- Assign a unique device name.
- Assign the IP address.

In New Module | Connection

- Assign further settings, e.g. the RPI settings.
- Add the device to the network with OK.

Select Connection

Different connections can be selected to suit any application:

- Select the correct connection directly when adding the device to the network, or
- call up the settings again by double-clicking on the device.

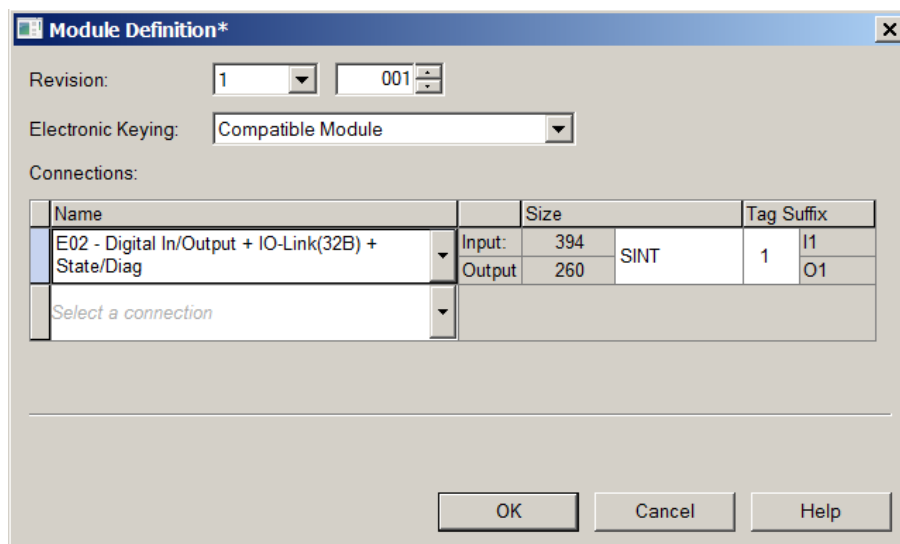

In Module Definition

- Click on Change.

A new window opens.

- Make the settings for the number or type of connection here Connection Matrix [▶ 34].
- Click on the preset connection (Exclusive Owner).
- Select the connection that meets the requirements.

A list of all available connections is displayed.



INFORMATION

The devices support up to 3 connections at the same time (1 exclusive owner and 2 non-exclusive owner connections).

7.3 Initial Start-Up without EDS

7.3.1 Connection, Parameters and Properties



INFORMATION

List-only connections are only established as multicast and also only to multicast non-list-only connections of the category via EDS.

This sets the configuration instance to be used to the used instance of the non-list-only connection.

7.3.2 Connection Matrix

Exclusive Owner Connection

Configuration Assembly				Description	Input Assembly		Output Assembly	
via EDS		via web server						
Instance	Length	In-stance	Length		Instance	Length	In-stance	Length
170	xx	171	0		101	394	111	260
E02		WE02		Digital IOs, IOL 32 bytes with status and diagnostics				

Input Only Connection

Configuration Assembly				Description	Input Assembly		Output Assembly	
via EDS		via web server						
Instance	Length	In-stance	Length		Instance	Length	In-stance	Length
170	xx	171	0		101	394	193	0
I02		WI02		Digital IOs, IOL 32 bytes with status and diagnostics				

List Only Connection

Name of connection	Description	Input Assembly		Output Assembly	
		Instance	Length	In-stance	Length

L02	Digital IOs, IOL 32 bytes with status and diagnostics	101	192	0
-----	---	-----	-----	---

7.3.3 Assemblies

Sequence of Configuration Bytes

Parameters	Instance 170	Instance 171
Total size in bytes	384	0
General	0 ... 1	
Diagnostics	2 ... 19	
IO-Link port X0	20 ... 43	
IO-Link port X1	44 ... 67	
IO-Link port X2	68 ... 91	
IO-Link port X3	92 ... 115	
IO-Link port X4	116 ... 139	
IO-Link port X5	140 ... 163	
IO-Link port X6	164 ... 187	
IO-Link port X7	188 ... 211	
OPC/UA	212 ... 217	
MQTT	218 ... 379	
WebUI	380 ... 381	
JSON	382 ... 383	

Sequence of Input Bytes

Parameters	Instance 101
Total size in bytes	394
Digital input DI	0 ... 1
DI Qualifier	2 ... 5
System Status	6 ... 9
IO-Link port X0 input data	10 ... 41
IO-Link port X0 input status	42 ... 49
IO-Link port X1 input data	50 ... 81
IO-Link port X1 input status	82 ... 89
IO-Link port X2 input data	90 ... 121
IO-Link port X2 input status	122 ... 129
IO-Link port X3 input data	130 ... 161
IO-Link port X3 input status	162 ... 169
IO-Link port X4 input data	170 ... 201
IO-Link port X4 input status	202 ... 209
IO-Link port X5 input data	210 ... 241
IO-Link port X5 input status	242 ... 249
IO-Link port X6 input data	250 ... 281
IO-Link port X6 input status	282 ... 289
IO-Link port X7 input data	290 ... 321
IO-Link port X7 input status	322 ... 329
Diagnostics buffer	330 ... 393

Sequence of Output Bytes

Parameters	Instance 111
Total size in bytes	260
Digital output	0 ... 1
IO-Link port X0 output data	2 ... 33
IO-Link port X1 output data	34 ... 65
IO-Link port X2Ausgangsdaten	66 ... 97
IO-Link port X3 output data	98 ... 129
IO-Link port X4 output data	130 ... 161
IO-Link port X5 output data	162 ... 193
IO-Link port X6 output data	194 ... 225
IO-Link port X7 output data	226 ... 257
Diagnostics confirmation	258 ... 259

7.3.4 Configuration Values



INFORMATION

Unexpected behavior of the device.

→ Use only the values listed in this manual.

General Parameters

Byte	Parameters	Value	Default value	Description
0	Pin/Port based IO layout for digital channels	IO Layout: 0 = Port based 1 = Pin based	0	Parameterizes the layout of the I/O data.

Diagnostic Parameters

Byte	Parameters	Value	Default value	Description
0	Global Diagnostic Report	0 = Disabled 1 = Enabled	1	Global diagnoses report
1	Under Voltage Sensor Supply Diagnostic Message	0 = Do not report 1 = Report	1	Diagnostic message under-voltage US
2 - 3	Under Voltage Sensor Supply Threshold	0 = Default 17500 = 17,5 V ... 18,0 V 18000 = 18,0 V ... 18,5 V 18500 = 18,5 V ... 19,0 V 19000 = 19,0 V ... 19,5 V 19500 = 19,5 V ... 20,0 V	0	Threshold value US at under-voltage
4	Under Voltage Actuator Supply Diagnostic Message	0 = Do not report 1 = Report	1	Diagnostic message under-voltage UA

Byte	Parameters	Value	Default value	Description
5 – 6	Under Voltage Actuator Supply Threshold	0 = Default 17500 = 17,5 V ... 18,0 V 18000 = 18,0 V ... 18,5 V 18500 = 18,5 V ... 19,0 V 19000 = 19,0 V ... 19,5 V 19500 = 19,5 V ... 20,0 V	0	Threshold value UA at undervoltage
7	No Actuator Supply Diagnostic Message	0 = Do not report 1 = Report	1	Diagnostics message no UA
8	LED Indication For Suppressed Diagnostic Messages	0 = No LED indication 1 = LED indication	0	LED indicator for suppressed diagnostic messages
9	Diagnostic Message Acknowledgement	0 = Disabled 1 = Enabled	0	Confirmation of the diagnostic message
10	Port X0 Diagnostic Report	0 = Report All Diagnostic Messages 1 = Report All Diagnostic Messages Except For Wire Break 2 = Report Only Wire Break Diagnostic Messages	0	Port X0 diagnostic report
11	Port X1 Diagnostic Report	0 = Report All Diagnostic Messages 1 = Report All Diagnostic Messages Except For Wire Break 2 = Report Only Wire Break Diagnostic Messages	0	Port X1 diagnostic report
12	Port X2 Diagnostic Report	0 = Report All Diagnostic Messages 1 = Report All Diagnostic Messages Except For Wire Break 2 = Report Only Wire Break Diagnostic Messages	0	Port X2 diagnostic report
13	Port X3 Diagnostic Report	0 = Report All Diagnostic Messages 1 = Report All Diagnostic Messages Except For Wire Break 2 = Report Only Wire Break Diagnostic Messages	0	Port X3 diagnostic report
14	Port X4 Diagnostic Report	0 = Report All Diagnostic Messages	0	Port X4 diagnostic report

Byte	Parameters	Value	Default value	Description
		1 = Report All Diagnostic Messages Except For Wire Break 2 = Report Only Wire Break Diagnostic Messages		
15	Port X5 Diagnostic Report	0 = Report All Diagnostic Messages 1 = Report All Diagnostic Messages Except For Wire Break 2 = Report Only Wire Break Diagnostic Messages	0	Port X5 diagnostic report
16	Port X6 Diagnostic Report	0 = Report All Diagnostic Messages 1 = Report All Diagnostic Messages Except For Wire Break 2 = Report Only Wire Break Diagnostic Messages	0	Port X6 diagnostic report
17	Port X7 Diagnostic Report	0 = Report All Diagnostic Messages 1 = Report All Diagnostic Messages Except For Wire Break 2 = Report Only Wire Break Diagnostic Messages	0	Port X7 diagnostic report

IO-Link Port X0 ... X7 Parameters

Byte	Parameters	Value	Default value	Description
0	IO-Link Function Pin 4	0 = Deactivated 1 = IO-Link Manual Configuration 2 = IO-Link Autostart 3 = Digital Input NO 4 = Digital Output 97 = Digital Input NC	0	IO-Link function pin 4
1	Validation&Backup	0 = No Device check 1 = Type compatible Device V1.0 2 = Type compatible Device V1.1 3 = Type compatible Device V1.1, Backup + Restore 4 = Type compatible Device V1.1, Restore	0	Validation and backup. See note *
2	Behavior Pin 2 (Ch1Y)	0 = Automatic Mode (DIO)	0	Behavior pin 2 (Ch1Y)

Byte	Parameters	Value	Default value	Description
		1 = Digital Input 2 = Digital Output 5 = AUX Power 6 = Digital Input NC 7 = Deactivated		
3	PortCycleTime **	0: As fast as possible 1 - 255: Bit0..5 Multiplier / Bit6..7 Time-Base[ms]	0	Port cycle time.
4 - 5	Vendor ID	Vendor ID of the attached IO-Link device for the use with validation setting	0	
6 - 9	Device ID	Device ID of the attached IO-Link device for the use with validation setting	0	
10	IO-Link Prozess Data Swap	0 = No Swap 1 = 16 Bit Swap In case of odd data length the last byte will not be touched 2 = 32 Bit Swap In case the data length is not on 4 byte boundary <ul style="list-style-type: none"> • 3 byte, swap of byte x with x+2. x+1 will not be touched • 3 byte, swap of byte x with x+2. x+1 will not be touched • 1 byte, byte will not be touched 3 = Full Swap	0	Swap settings for the IO-Link process data. Applies to input and output data.
11	IO-Link Event Integration	0 = Standard Integration 1 = wenglor Integration 2 = wenglor IO-Link Extended Integration	0	IO-Link event integration
12	Digital Input Signal Filter Pin 4	0 = No Filter 1 = 1 ms 2 = 3 ms 3 = 5 ms 4 = 10 ms 5 = 15 ms	0	Digital input signal filter pin 4
13	Digital Input Signal Filter Pin 2	0 = No Filter 1 = 1 ms	0	Digital input signal filter pin 2

Byte	Parameters	Value	Default value	Description
		2 = 3 ms 3 = 5 ms 4 = 10 ms 5 = 15 ms		
14	Digital Output Failsafe Mode Pin 4	0 = Force 0 1 = Force 1 2 = Last State	0	Digital output fail-safe mode pin 4
15	Digital Output Failsafe Mode Pin 2	0 = Force 0 1 = Force 1 2 = Last State	0	Digital output fail-safe mode pin 2
16	Digital Port Function Configuration Pin 1	0 = Deactivated 1 = L+ (US) Sensor Supply	1	Digital connection function configuration pin 1
17	Output Current Limitation for Pin 1	0 = 0,5 A 1 = 1,0 A 2 = 1,5 A 3 = 2,0 A	3	Output current limitation for pin 1
18	Output Current Limitation for Pin 2	0 = 0,5 A 1 = 1,0 A 2 = 1,5 A 3 = 2,0 A	3	Output current limitation for pin 2
19	Output Current Limitation for Pin 4	0 = 0,5 A 1 = 1,0 A 2 = 1,5 A 3 = 2,0 A	0	Output current limitation for pin 4
20 - 23	RESERVED		0	Reserved for future use.



INFORMATION

When switching to the “Restore” state, any device configurations previously saved in the device are discarded, especially when switching from “Backup & Restore” to “Restore”.

When a compatible device is connected for the first time in the “Restore” state, the master retrieves the data storage data (one-time backup) from the device once, saves it and sends this data in sequence to each newly connected compatible device with a different configuration (restore).



INFORMATION

These parameters are repeated for each IO-Link port of the device.

PortCycleTime **

The PortCycleTim is composed as follows:

- Bits 0...5 contain the multiplier for the PortCycleTime
- Bits 6...8 contain the time base for the PortCycleTime

If all bits are set to 0, the IO-Link master will operate the IO-Link device with the shortest cycle time supported by the IO-Link device.

A detailed description can be found in the IO-Link specification: IO-Link Interface and System Specification Version 1.1.3, June 2019, section B1.3.

Calculation of the PortCycleTime:

Time base coding (bit 6..7)	Time base (bit 0..5)	Calculation	Adjustable PortCycleTime
0	0.1 ms	Multiplier x time base	0.4 ms ... 6.3 ms
1	0.4 ms	6.4 ms + multiplier x time base	6.4 ms ... 31.6 ms
2	1.6 ms	32.0 ms + multiplier x time base	32.0 ms ... 132.8 ms
3	Reserved	Reserved	Reserved

The following table contains pre-calculated values for the PortCycleTime:

PortCycleTime	PortCycleTime-coding (bit 6..7)	Multiplier (bit 0..5)	Time base coding (bit 6..7)
1.6 ms	16	16	0
2 ms	20	20	0
3.2 ms	32	32	0
4.0 ms	40	40	0
4.8 ms	148	48	0
6.4 ms	64	0	1
8.0 ms	68	4	1
10.0 ms	73	9	1
12.0 ms	78	14	1
16.0 ms	88	24	1
20.0 ms	98	34	1
20.8 ms	100	36	1
32.0 ms	128	0	2
40.0 ms	133	5	2
64.0 ms	148	20	2
80.0 ms	158	30	2
120.0 ms	183	55	2
128.0 ms	188	60	2

OPC/UA Parameters

Byte	Parameters	Value	Default value	Description
0	Use Of OPC/UA	0 = Disabled 1 = Enabled	0	Activates or disables the OPC/UA Server function
1 – 2	OPC/UA TCP Port Number	1024 – 49151 TCP port number	4840	Defines on which port the OPC/UA Server is active
3	Allow OPC/UA Clients to Write ISDU Data	0 = Disabled 1 = Enabled	0	Activates or disables the option to write ISDU data from a OPC/UA client
4	Allow OPC/UA Clients to Write Output Data	0 = Disabled 1 = Enabled	0	Activates or disables the option to write output data from a OPC/UA client
5	RESERVED		0	Reserved for future use

MQTT Parameters

Byte	Parameters	Value	Default value	Description
0	Use Of MQTT	0 = Disabled 1 = Enabled	0	Activates or disables the MQTT function
1 - 4	MQTT Server IP Address	Value of IP MQTT Server IP Address	0xC0AB01FE = 192.171.1.254	Sets the IP address of the MQTT server
5 - 27	MQTT Client ID	Client ID of the MQTT Client	"MqttClient"	Sets the ID which the device shall use to send MQTT data
28 - 91	MQTT Client Head Topic	MQTT Client Head Topic	""	Sets the Head Topic to which the device writes MQTT data
92 - 155	MQTT Topic For System Data	MQTT Topic For System Data	""	Set the topic for system data to which the device writes MQTT data

WebUI Parameters

Byte	Parameters	Value	Default value	Description
0	Use Of WebUI	0 = Disabled 1 = Enabled	1	Activates or disables the WebUI
1	RESERVED		0	Reserved for future use

JSON Parameters

Byte	Parameters	Value	Default value	Description
0	Use Of JSON	0 = Disabled 1 = Enabled	0	Activates or disables the option to send and receive JSON communication
1	RESERVED		0	Reserved for future use

8 Configuration and Parameterization



WARNING

Impairment of the protection function by changing the configuration of the devices.

Only an authorized person may make changes to the configuration.

For configuration changes, use the password hierarchy provided by your engineering software.

The effectiveness of the safety device must be retested each time its configuration is changed.

8.1 Configuration

Overview

There are two options for configuring the devices.

On the one hand, an EDS file is available for download on the wenglor website.

As described in section Reading In the EDS Files [► 30], these can be imported into the programming software in order to use the advantages of the preconfigured connections.

On the other hand, it is possible to configure the devices via the integrated web server.



INFORMATION

To apply index changes via the web server and adopt an acyclical ISDU Writes into the DataStorage, a ParamDownloadStore Command must be sent after the index changes.

The ParamDownloadStore Command can be triggered by writing value 0x05 to index 0x02

Configuration via EDS

After importing the EDS into the programming software and selecting a connection suitable for the application, the configuration files can be found in the controller tags.

The input and output tags associated with the device can be found next to it.

Name	Value	Force Mask	Style	Data Type	Class	Description	Constant
EP8E001:C		(...)	(...)		Standard		<input type="checkbox"/>
EP8E001:C.Pin_Port_based_IO_layout_for_digital_cha	0		Decimal	SINT	Standard		
EP8E001:C.Quick_Connect	0		Decimal	SINT	Standard		
EP8E001:C.Diag_Param_Global_Diagnostic_Report	1		Decimal	SINT	Standard		
EP8E001:C.Diag_Param_Under_Voltage_Sensor_Supply1	1		Decimal	SINT	Standard		
EP8E001:C.Diag_Param_Under_Voltage_Sensor_Supply2	0		Decimal	INT	Standard		
EP8E001:C.Diag_Param_Under_Voltage_Actuator_Supp1	1		Decimal	SINT	Standard		
EP8E001:C.Diag_Param_Under_Voltage_Actuator_Supp2	0		Decimal	INT	Standard		
EP8E001:C.Diag_Param_No_Actuator_Supply_Diagnosti	1		Decimal	SINT	Standard		
EP8E001:C.Diag_Param_LED_Indication_For_Suppresse	0		Decimal	SINT	Standard		
EP8E001:C.Diag_Param_Diagnostic_Message_Acknowled	0		Decimal	SINT	Standard		
EP8E001:C.Diag_Param_Port_X0_Diagnostic_Report	0		Decimal	SINT	Standard		
EP8E001:C.Diag_Param_Port_X1_Diagnostic_Report	0		Decimal	SINT	Standard		
EP8E001:C.Diag_Param_Port_X2_Diagnostic_Report	0		Decimal	SINT	Standard		
EP8E001:C.Diag_Param_Port_X3_Diagnostic_Report	0		Decimal	SINT	Standard		
EP8E001:C.Diag_Param_Port_X4_Diagnostic_Report	0		Decimal	SINT	Standard		

All configuration tags have a specific name that describes the function of the areas.

Enter the appropriate values for your application. The device is configured correctly each time it is connected to the controller.

For information on the adjustable values, see section Configuration Values [► 36]

WebUI

The device can also be configured via WebUI if required. To use this function, one of the Exclusive Owner connections starting with the symbols “WE” must be selected when configuring the connection in the PLC software.

How to navigate to the parameters is explained in section Access and Login [► 80].

8.2 Adjusting the Parameters

Navigate to the Controller Tags in the Controller Organizer window located on the left side of the program window.

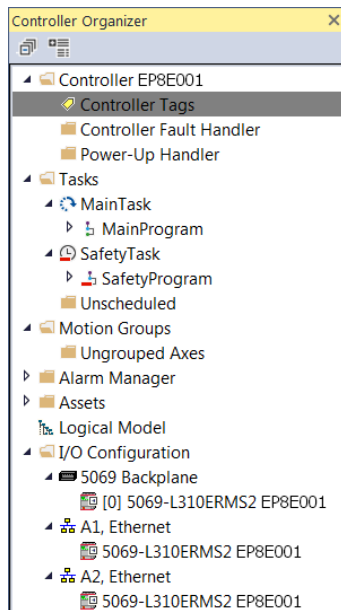

- Double-click the Controller Tags entry.
- The overview of the process and configuration data opens.

Name	Value	Force Mask	Style	Data Type	Class	Description	Constant
EP8E001:C		(...)	(...)	_0280:54611_3DF...	Standard		☐
EP8E001:I1		(...)	(...)	_0280:54611_B60...	Standard		☐
EP8E001:O1		(...)	(...)	_0280:54611_9E88...	Standard		☐

- Click on the plus symbol in the configuration data line Name_Of_Module: C. All parameters of the device expand.
- Enter the values for the application.



INFORMATION

Parameters are transferred to Forward Open Telegram (power reset or disconnection required).

Adjustable values of the parameters, see section Configuration Values [► 36]

8.3 Requested Packet Interval (RPI) Configuration

Setting RPI Values

Search Device.

When setting up an EtherNet/IP system, the RPI value in the controller must be set carefully. To set the RPI values, the properties must be opened.

In the **Controller Organizer**:

- Double-click on the device or
- Right-click the device and select Properties from the context menu.

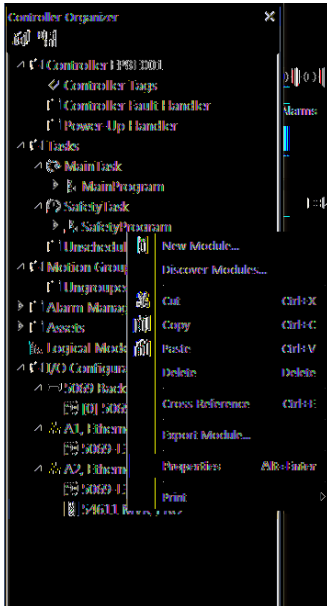

Setting RPI Values

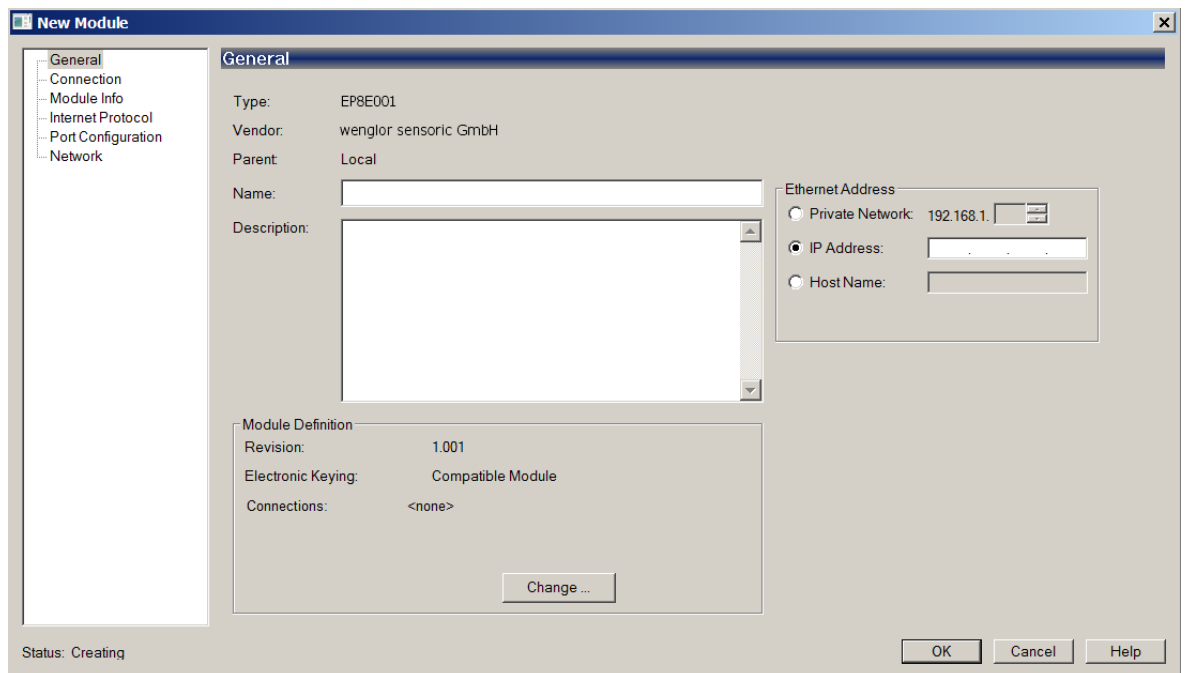

Click the **Connection** tag.

Under the **Requested Packet Interval (RPI) (ms)** column, set the desired RPI values.



INFORMATION

The RPI minimum is 1 ms.

8.4 Device Level Ring (DLR) Configuration

Device Level Ring (DLR) is a protocol that allows ring topology with EtherNet/IP devices. The ring network consists of at least one ring supervisor and any number of participants. There are two methods for building the topology and detecting line breaks within the ring:

1. Beacon-based
2. Announce-based

Prerequisites for configuration and diagnostics:

- Participants support the DLR
- The DLR object (0 x 47) is implemented by the participant

The use of non-DLR-capable devices in an EtherNet/IP ring network is not excluded, but results in an increased ring recovery time when the ring topology is separated.



INFORMATION

The devices described in this manual support beacon-based DLR technology.

8.5 IO-Link Configuration

The EP8E001 enables the configuration and parameterization of IO-Link devices via IO-Link Device Configuration Explicit Messages in EtherNet/IP.

IO-Link Device Configuration via EtherNet/IP Explicit Messages

It is possible to parameterize the connected IO-Link devices using EtherNet/IP explicit messages.



INFORMATION

For more information, see section Diagnostic Structure in the Control System [► 73]

8.6 Industrial Internet of Things (IIoT)

8.6.1 JSON

General JSON Settings

No.	REST API URL	Description	Supports
1	GET /iolink/v1/gateway/identification	Identification of the gateway	OK
2	GET /iolink/v1/gateway/capabilities	Capabilities of the gateway	OK
3	GET /iolink/v1/gateway/configuration	Read network configuration of the gateway	OK
4	POST /iolink/v1/gateway/configuration	Write network configuration of the gateway	OK
5	POST /iolink/v1/gateway/reset	Reset the gateway including all masters	-
6	POST /iolink/v1/gateway/reboot	Reboot the gateway including all masters	-

No.	REST API URL	Description	Supports
7	GET /iolink/v1/gateway/events	Event log containing all events from gateway, masters, ports and devices	OK
8	GET /iolink/v1/masters	Get all available master number keys and identification information	OK
9	GET /iolink/v1/masters/\$MASTER_NUMBER/capabilities	Capabilities of the master	OK
10	GET /iolink/v1/masters/\$MASTER_NUMBER/identification	Read identification of the master	OK
11	POST /iolink/v1/masters/\$MASTER_NUMBER/identification	Write identification of the master	OK
12	GET /iolink/v1/masters/\$MASTER_NUMBER/ports	Get all available port number keys	OK
13	GET /iolink/v1/masters/\$MASTER_NUMBER/ports/\$PORT_NUMBER/capabilities	Read capability information of the specified port	OK
14	GET /iolink/v1/masters/\$MASTER_NUMBER/ports/\$PORT_NUMBER/status	Read status of the master	OK
15	GET /iolink/v1/masters/\$MASTER_NUMBER/ports/\$PORT_NUMBER/configuration	Read configuration of the specified port	OK
16	POST /iolink/v1/masters/\$MASTER_NUMBER/ports/\$PORT_NUMBER/configuration	Write configuration of the specified port	OK
17	GET /iolink/v1/masters/\$MASTER_NUMBER/ports/\$PORT_NUMBER/datastorage	Read data storage content of the specified port	OK
18	POST /iolink/v1/masters/\$MASTER_NUMBER/ports/\$PORT_NUMBER/datastorage	Write data storage content of the specified port	OK
19	GET /iolink/v1/devices	Address all devices of all masters	OK
20	GET /iolink/v1/devices/{deviceAlias}/capabilities	Read capability information of the specified device	OK
21	GET /iolink/v1/devices/{deviceAlias}/identification	Read identification information of the specified device	OK
22	POST /iolink/v1/devices/{deviceAlias}/identification	Write identification information of the specified device	-
23	GET /iolink/v1/devices/{deviceAlias}/processdata/value?format=byteArray	Read process data value from the specified device	OK
24	GET /iolink/v1/devices/{deviceAlias}/processdata/getdata/value?format=byteArray	Read process data input value from the specified device	OK
25	GET /iolink/v1/devices/{deviceAlias}/processdata/setdata/value?format=byteArray	Read process data output value from the specified device	OK
26	POST /iolink/v1/devices/{deviceAlias}/processdata/value	Write the process data output value to the specified device	OK
27	GET /iolink/v1/devices/{deviceAlias}/parameters/{index}/value/?format=byteArray	Read a specific parameter value and its sub-parameter values (if the parameter has complex type) with the given index of the device	OK
28	GET /iolink/v1/devices/{deviceAlias}/parameters/{index}/subindices/{subindex}/value/?format=byteArray	Read the value of a specific sub-parameter with the given index and subindex	OK
29	GET /iolink/v1/devices/{deviceAlias}/parameters/{parameterName}/value/?format=byteArray	Read a specific parameter value with the given name	-

No.	REST API URL	Description	Sup-ports
30	POST /iolink/v1/devices/{deviceAlias}/parameters/{index}/value	Write the parameter with the given index to the device	OK
31	POST /iolink/v1/devices/{deviceAlias}/parameters/{parameterName}/value	Write the parameter with the given name to the device	-
32	POST /iolink/v1/devices/{deviceAlias}/parameters/{index}/subindices/{subindex}/value	Write the sub-parameter with the given index and subindex to the device	OK
33	POST /iolink/v1/devices/{deviceAlias}/parameters/{parameterName}/subindices/{subParameterName}/value	Write the sub-parameter with the given parameter name and sub-parameter name to the device	OK
34	POST /iolink/v1/devices/{deviceAlias}/blockparametrization/?format=byteArray	Read or write one or more parameters as a block	OK
35	GET /iolink/v1/devices/{deviceAlias}/events	Read event log from the specified device	OK
36	GET /iolink/v1/mqtt/configuration	Read configuration of MQTT clients	OK
37	POST /iolink/v1/mqtt/configuration	Write configuration of MQTT clients	-
38	GET /iolink/v1/mqtt/topics	Read list of MQTT topics	-
39	POST /iolink/v1/mqtt/topics	Write list of MQTT topics	-
40	DELETE /iolink/v1/mqtt/topics/{topicID}	Delete a specific MQTT topic	-
41	GET /iolink/v1/mqtt/topics/{topicID}	Read a specific MQTT topic	-
42	GET /iolink/v1/mqtt/connectionstatus	Read connection status	OK

Vendor-Specific JSON Settings

No.	REST API URL	Description	Sup-ports
43	GET /iolink/v1/vendor/masters/\$MASTER_NUMBER/diagnostics/configuration	Diagnostic configuration of the master	OK
44	GET /iolink/v1/vendor/masters/\$MASTER_NUMBER/diagnostics/value	Diagnostic values of the master	OK
45	GET /iolink/v1/vendor/masters/\$MASTER_NUMBER/ports/\$PORT_NUMBER/statistics/current	Current statistic values of the specified port of the master	OK
46	GET /iolink/v1/vendor/masters/\$MASTER_NUMBER/ports/\$PORT_NUMBER/statistics/voltage	Voltage statistic values of the specified port of the master	OK
47	GET /iolink/v1/vendor/masters/\$MASTER_NUMBER/ports/\$PORT_NUMBER/statistics/temperature	Temperature statistic values of the specified port of the master	OK
48	GET /iolink/v1/vendor/masters/1/ports/1/statistics/stack	IO-Link stack statistic values of the specified port of the master	-
49	GET /iolink/v1/vendor/masters/\$MASTER_NUMBER/ports/\$PORT_NUMBER/diagnostics/configuration	Diagnostic configuration of the specified port of the master	OK
50	GET /iolink/v1/vendor/masters/\$MASTER_NUMBER/ports/\$PORT_NUMBER/diagnostics/current	Diagnostic current value of the specified port of the master	OK

No.	REST API URL	Description	Supports
51	GET /iolink/v1/vendor/masters/ \$MASTER_NUMBER/ports/ \$PORT_NUMBER/diagnostics/voltage	Diagnostic voltage value of the specified port of the master	OK
52	GET /iolink/v1/vendor/masters/ \$MASTER_NUMBER/ports/ \$PORT_NUMBER/diagnostics/temperature	Diagnostic temperature value of the specified port of the master	OK

8.6.2 MQTT



INFORMATION

When activating MQTT, JSON must be activated.

MQTT Settings

No.	REST API URL	Description
1	\$MQTT_CLIENT_HEAD_TOPIC/iolink/v1/gateway/identification	Identification of the gateway
2	\$MQTT_CLIENT_HEAD_TOPIC/iolink/v1/gateway/capabilities	Capabilities of the gateway
3	\$MQTT_CLIENT_HEAD_TOPIC/iolink/v1/gateway/configuration	Network configuration of the gateway
4	\$MQTT_CLIENT_HEAD_TOPIC/iolink/v1/masters	Get all available master number keys and identification information
5	\$MQTT_CLIENT_HEAD_TOPIC/iolink/v1/vendor/masters/ \$MASTER_NUMBER/diagnostics/value	Diagnostic values of the master
6	\$MQTT_CLIENT_HEAD_TOPIC/iolink/v1/vendor/masters/ \$MASTER_NUMBER/diagnostics/configuration	Diagnostic configuration of the master
7	\$MQTT_CLIENT_HEAD_TOPIC/iolink/v1/masters/ \$MASTER_NUMBER/capabilities	Capabilities of the master
8	\$MQTT_CLIENT_HEAD_TOPIC/iolink/v1/masters/ \$MASTER_NUMBER/identification	Identification of the master
9	\$MQTT_CLIENT_HEAD_TOPIC/iolink/v1/masters/ \$MASTER_NUMBER/ports	Get all available port number keys
10	\$MQTT_CLIENT_HEAD_TOPIC/iolink/v1/masters/ \$MASTER_NUMBER/ports/\$PORT_NUMBER/capabilities	Read capability information of the specified port
11	\$MQTT_CLIENT_HEAD_TOPIC/iolink/v1/masters/ \$MASTER_NUMBER/ports/\$PORT_NUMBER/status	Read actual status of the specified port
12	\$MQTT_CLIENT_HEAD_TOPIC/iolink/v1/masters/ \$MASTER_NUMBER/ports/\$PORT_NUMBER/configuration	Read/Write configuration of the specified port
13	\$MQTT_CLIENT_HEAD_TOPIC/iolink/v1/vendor/masters/ \$MASTER_NUMBER/ports/\$PORT_NUMBER/diagnostics/Configuration	Diagnostic configuration of the specified port of the master
14	\$MQTT_CLIENT_HEAD_TOPIC/iolink/v1/vendor/masters/	Diagnostic current value of the specified port of the master

No.	REST API URL	Description
	\$MASTER_NUMBER/ports/\$PORT_NUMBER/diagnostics/current	
15	\$MQTT_CLIENT_HEAD_TOPIC/iolink/v1/vendor/masters/ \$MASTER_NUMBER/ports/\$PORT_NUMBER/diagnostics/voltage	Diagnostic voltage value of the specified port of the master
16	\$MQTT_CLIENT_HEAD_TOPIC/iolink/v1/vendor/masters/ \$MASTER_NUMBER/ports/\$PORT_NUMBER/diagnostics/temperature	Diagnostic temperature value of the specified port of the master
17	\$MQTT_CLIENT_HEAD_TOPIC/iolink/v1/vendor/masters/ \$MASTER_NUMBER/ports/\$PORT_NUMBER/statistics/current	Current statistic values of the specified port of the master
18	\$MQTT_CLIENT_HEAD_TOPIC/iolink/v1/vendor/masters/ \$MASTER_NUMBER/ports/\$PORT_NUMBER/statistics/voltage	Voltage statistic values of the specified port of the master
19	\$MQTT_CLIENT_HEAD_TOPIC/iolink/v1/vendor/masters/ \$MASTER_NUMBER/ports/\$PORT_NUMBER/statistics/temperature	Temperature statistic values of the specified port of the master
20	\$MQTT_CLIENT_HEAD_TOPIC/iolink/v1/devices/ \$DEVICE_ALIAS/processdata/value	Read/Write process data value from/to the specified device
21	\$MQTT_CLIENT_HEAD_TOPIC/iolink/v1/devices/ \$DEVICE_ALIAS/processdata/getdata/value	Read process data input value from the specified device
22	\$MQTT_CLIENT_HEAD_TOPIC/iolink/v1/devices/ \$DEVICE_ALIAS/processdata/setdata/value	Temperature statistic values of the specified port of the master
23	\$MQTT_CLIENT_HEAD_TOPIC/iolink/v1/devices/ \$DEVICE_ALIAS/events	Read/Write process data value from/to the specified device
24	\$MQTT_CLIENT_HEAD_TOPIC/Asset	Information about the publisher (network, vendor, firmware)
25	\$MQTT_CLIENT_HEAD_TOPIC/iolink/v1/devices/ \$DEVICE_ALIAS/events	Status of the publisher (online when connected)

8.6.3 OPC UA

The devices mentioned in the screenshots serve as examples.

The device has an OPC-UA server. An OPC UA client can connect to the device and access the following parameters:

- Device identification,
- Configuration parameters,
- Process data,
- Measured values,
- Diagnostics Information,
- Statistical information, etc.

The OPC UA client connects using the following URL:

opc.tcp://IP address:4840



INFORMATION

For **IP address**, the IP address of the device is used.

The client can access device parameters anonymously (read only) or with username/password (read and write). The user name and password are set with the web server.

The following figure shows a section of the device's information model.

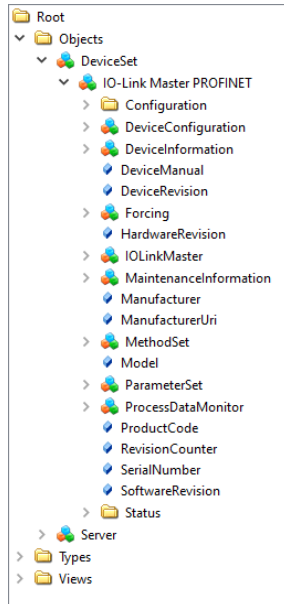

The following figure shows a section of the information model of an IO-Link port.

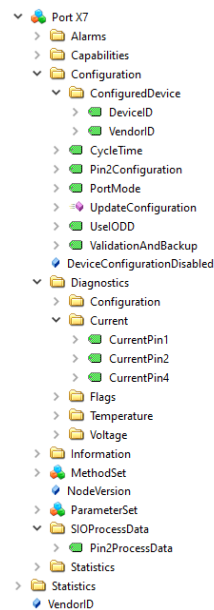

8.6.3.1 Authenticate

User Login

For OPC UA, the same users and passwords apply as documented in the web server description 10 “Web server”

A connection to the OPC UA server is started with the user “guest”, with which read access to the OPC UA objects is possible.

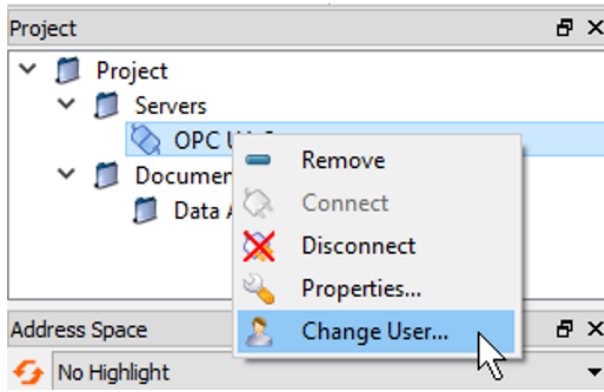

The user must be switched over for further actions.

- Username <admin>
- Password <private>

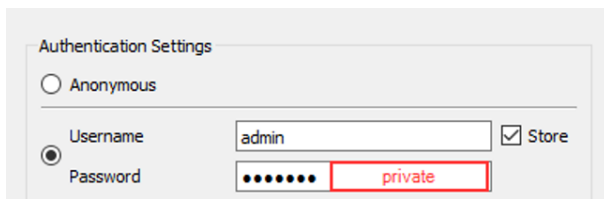

Forcing

Digital outputs can be switched manually (forcing) via OPC UA.

Step 1

Use the GetForcingID method to generate an ID from the device.

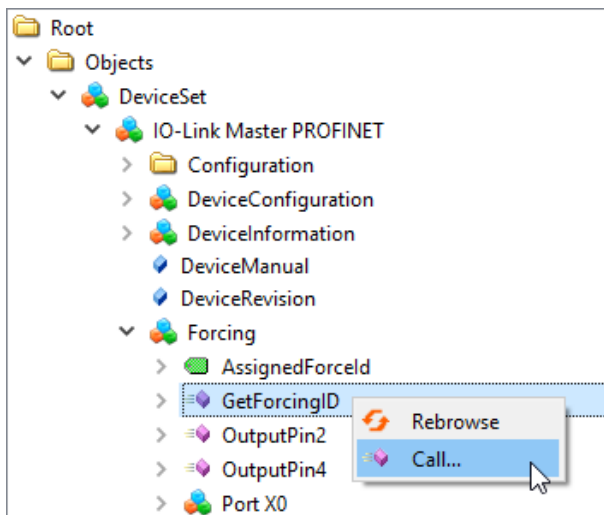

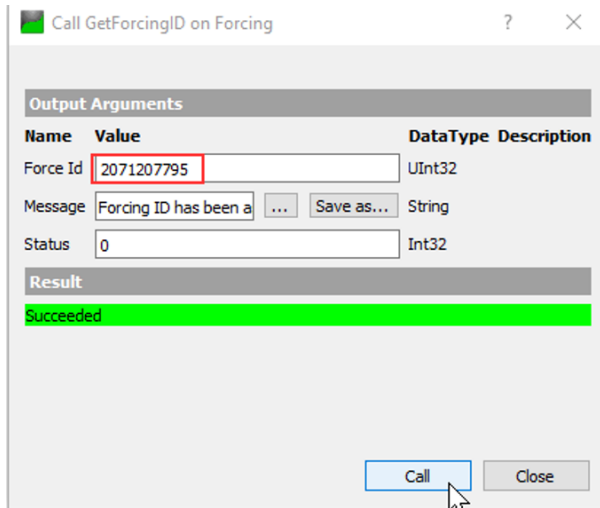

INFORMATION

The ForcingID is only valid for 10 seconds. The validity is extended to 10 seconds each time a forcing function is called up.

Step 2

Set digital outputs using the OutputPin2 or OutputPin4 methods.

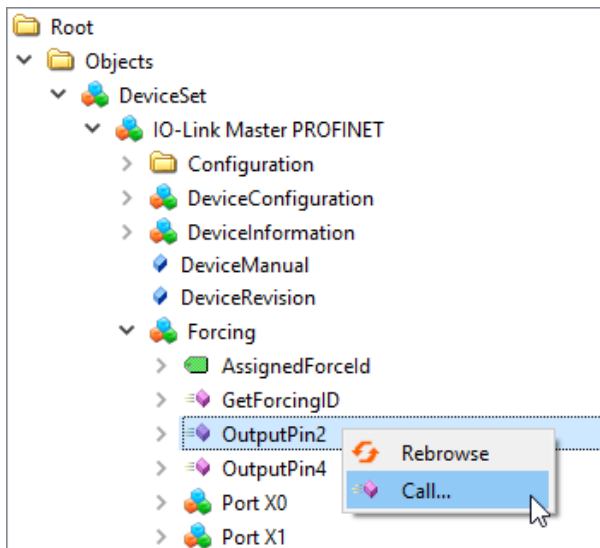

The method expects the received forcing ID, a bit mask and data to be written to be entered as parameters.

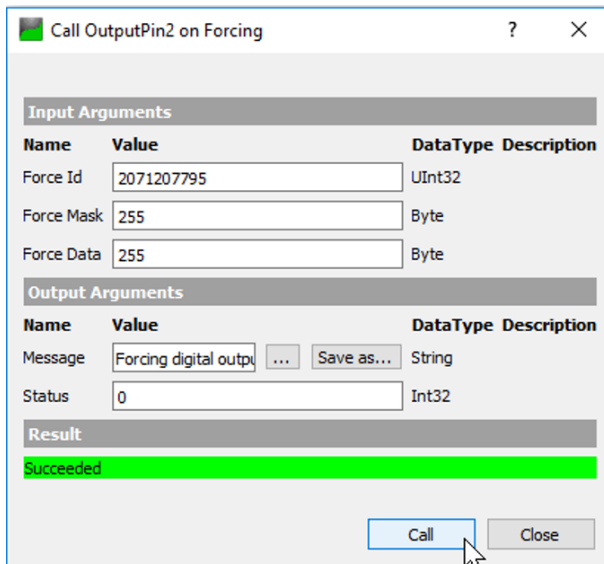

8.6.3.2 Device Identification

The device provides nodes for device identification. For example, the OPC UA client can read the version of the device firmware used in the **SoftwareRevision** node.

Node name	Node class	Access	Description
Manufacturer	Variable	Read	Device manufacturer
ManufacturerUri	Variable	Read	Device manufacturer URL
Model	Variable	Read	Model designation of the device
ProductCode	Variable	Read	Product code of the device
RevisionCounter	Variable	Read	Device hardware revision
SerialNumber	Variable	Read	Serial number of device
SoftwareRevision	Variable	Read	Device firmware revision/version

#	Server	Node Id	Display Name	Value	Datatype	Source Timestamp	Server Timestamp	StatusCode
1	OPC UA ...	NS6[Numeric]161	Manufacturer	"en", "wenglor ...	LocalizedText	06:27:09.000	06:27:09.000	Good
2	OPC UA ...	NS6[Numeric]166	ManufacturerUri	www.wenglor.c...	String	06:27:16.000	06:27:16.000	Good
3	OPC UA ...	NS6[Numeric]162	Model	"en", "IO-Link ...	LocalizedText	06:27:38.000	06:27:38.000	Good
4	OPC UA ...	NS6[Numeric]167	ProductCode	EP8P001	String	06:27:49.000	06:27:49.000	Good
5	OPC UA ...	NS6[Numeric]163	RevisionCounter	1	Int32	06:27:51.000	06:27:51.000	Good

8.6.3.3 Configuration Parameters

The OPC UA server provides nodes with configuration parameters of the device. For example, the OPC UA client can read the upper limit for the temperature in the **OverTemperature** node.

Device-Related Configuration Parameters

Node name	Node class	Access	Default	Description
CurrentHysteresis	Variable	Read	10 mA	Current hysteresis, unit: mA If the current exceeds the limit value, the current must first fall below the limit value again by the hysteresis value in order to cancel the diagnostics.
OverTemperature	Variable	Read	70 °C	Upper limit for the temperature of a port, unit: 0.1 °C
OverVoltageL	Variable	Read	30 V	Upper limit value for the voltage in supply line 1, pins can be monitored with the function L+, DI, DO, DIO, IO-Link, unit: mV

Node name	Node class	Access	Default	Description
OverVoltageL2	Variable	Read	30 V	Upper limit for the voltage in supply line 2, unit: mV
TemperatureHysteresis	Variable	Read	2 °C	Temperature hysteresis, unit: 0.1 °C If the temperature exceeds the limit value, the temperature must first fall below the limit value by the hysteresis value in order to cancel the diagnostics.
UnderTemperature	Variable	Read	-25 °C	Lower limit for the temperature of a port, unit: 0.1 °C
UnderVoltage L	Variable	Read	18 V	Lower limit value for the voltage in supply line 1, pins can be monitored with the function L+, DI, DO, DIO, IO-Link, unit: mV
UnderVoltage L2	Variable	Read	18 V	Lower limit for the voltage in supply line 2, unit: mV
Voltage Hysteresis	Variable	Read	300 mV	Voltage hysteresis, unit: mV If the voltage exceeds the limit value, the voltage must first drop back below the limit value by the hysteresis value in order to cancel the diagnostics.

#	Server	Node Id	Display Name	Value	Datatype	Source Timestamp	Server Timestamp	Statuscode
1	OPC UA ...	NS5(Numeric...	CurrentHysteresis	10	UInt16	06:29:43.000	06:29:43.000	Good
2	OPC UA ...	NS5(Numeric...	OverTemperature	70	Float	06:29:48.000	06:29:48.000	Good
3	OPC UA ...	NS5(Numeric...	OverVoltageL	30000	Int32	06:29:51.000	06:29:51.000	Good
4	OPC UA ...	NS5(Numeric...	OverVoltageL2	30000	Int32	06:29:54.000	06:29:54.000	Good
5	OPC UA ...	NS5(Numeric...	TemperatureHy...	2	Float	06:29:56.000	06:29:56.000	Good
6	OPC UA ...	NS5(Numeric...	UnderTemperat...	-40	Float	06:29:57.000	06:29:57.000	Good
7	OPC UA ...	NS5(Numeric...	UnderVoltageL	17000	Int32	06:29:59.000	06:29:59.000	Good
8	OPC UA ...	NS5(Numeric...	UnderVoltageL2	17000	Int32	06:30:00.000	06:30:00.000	Good
9	OPC UA ...	NS5(Numeric...	VoltageHysteresis	300	UInt16	06:30:01.000	06:30:01.000	Good

Port-Related Configuration Parameters

Node name	Node class	Access	Default	Description
OverCurrentPin1, OverCurrentPin2, OverCurrentPin4	Variable	Read	0	Warning level for upper current limit at pin 1, pin 2 or pin 4, unit: 1 mA 0: Monitoring not activated
UnderCurrentPin1, UnderCurrentPin2, UnderCurrentPin4	Variable	Read	0	Warning level for lower current limit at pin 1, pin 2 or pin 4, unit: 1 mA 0: Monitoring not activated

The screenshot shows the 'Address Space' tree on the left and the 'Data Access View' table on the right. The tree is expanded to 'Port X0' > 'Diagnostics' > 'Configuration', with 'UnderCurrentPin4' selected. The table lists 6 rows of data for various pins.

#	Server	Node Id	Display Name	Value	Datatype	Source Timestamp	Server Timestamp	Statuscode
1	OPC UA ...	NS6[Numeric]...	OverCurrentPin1	0	Int32	06:31:26.000	06:31:26.000	Good
2	OPC UA ...	NS6[Numeric]...	OverCurrentPin2	0	Int32	06:31:26.000	06:31:26.000	Good
3	OPC UA ...	NS6[Numeric]...	OverCurrentPin4	0	Int32	06:31:27.000	06:31:27.000	Good
4	OPC UA ...	NS6[Numeric]...	UnderCurrentPi...	0	Int32	06:31:28.000	06:31:28.000	Good
5	OPC UA ...	NS6[Numeric]...	UnderCurrentPi...	0	Int32	06:31:28.000	06:31:28.000	Good
6	OPC UA ...	NS6[Numeric]...	UnderCurrentPi...	0	Int32	06:31:29.000	06:31:29.000	Good

8.6.3.4 Process Data

The OPC UA server provides nodes with process data. For example, the OPC UA client can read the value at pin 2 of a port in the node **Pin2ProcessData**.

Node name	Node class	Access	Description
Pin2ProcessData	Variable	Read	Process data to pin 2
Pin4ProcessData	Variable	Read	Process data to pin 4

The screenshot shows the 'Address Space' tree on the left and the 'Data Access View' table on the right. The tree is expanded to 'Port X0' > 'Diagnostics' > 'SIOPProcessData', with 'Pin2ProcessData' selected. The table lists 2 rows of data for Pin2ProcessData and Pin4ProcessData.

#	Server	Node Id	Display Name	Value	Datatype	Server Timestamp	Source Timestamp	Statuscode
1	OPC UA ...	NS6[Numeric]...	Pin2ProcessData	false	Boolean	06:32:34.000	06:32:34.000	Good
2	OPC UA ...	NS6[Numeric]...	Pin4ProcessData	false	Boolean	06:32:35.000	06:32:35.000	Good

8.6.3.5 Measured Values

The OPC UA server provides nodes with calculated measured values. For example, the OPC UA client can read the calculated sum current of supply line 1 in node **SumCurrentL**.

Device-Related Measured Values

Node name	Node class	Access	Description
SumCurrentL	Variable	Read	Total current calculated from individual measurements in supply line 1, unit: mA
SumCurrentL2	Variable	Read	Total current calculated from individual measurements in supply line 2, unit: mA
MeanTemperature	Variable	Read	Mean value for the temperature of the assembly, calculated from the temperature values measured individually at the three chips, unit: °C
MeanVoltageL	Variable	Read	Mean voltage in supply line 1, unit: mV
MeanVoltageL2	Variable	Read	Mean voltage in supply line 2, unit: mV

The screenshot shows the 'Data Access View' window. On the left is a tree view of the address space, with 'IO-Link Master PROFINET' expanded to show various nodes. On the right is a table with the following columns: #, Server, Node Id, Display Name, Value, Datatype, Server Timestamp, Source Timestamp, and Statuscode. The table contains five rows of data:

#	Server	Node Id	Display Name	Value	Datatype	Server Timestamp	Source Timestamp	Statuscode
1	OPC UA ...	NS6(Numeric...	SumCurrentL	89	Int32	06:34:44.000	06:34:44.000	Good
2	OPC UA ...	NS6(Numeric...	SumCurrentL2	0	Int32	06:34:25.000	06:34:25.000	Good
3	OPC UA ...	NS6(Numeric...	SumCurrentL2	34.5	Float	06:34:29.000	06:34:29.000	Good
4	OPC UA ...	NS6(Numeric...	MeanVoltageL	23837	Int32	06:34:44.000	06:34:44.000	Good
5	OPC UA ...	NS6(Numeric...	MeanVoltageL2	24245	Int32	06:34:44.000	06:34:44.000	Good

Port-Related Measured Values

Node name	Node class	Access	Description
CurrentPin1, CurrentPin2, CurrentPin4	Variable	Read	Current measured at pin 1, pin 2 or pin 4, unit: mA
TemperaturePin1, TemperaturePin2, TemperaturePin4	Variable	Read	Temperature measured at pin 1, pin 2 or pin 4, unit: °C
VoltagePin1, VoltagePin2, VoltagePin4	Variable	Read	Voltage measured at pin 1, pin 2 or pin 4, unit: mA

#	Server	Node Id	Display Name	Value	Datatype	Server Timestamp	Source Timestamp	Statuscode
1	OPC UA ...	NS0(Numeric...	CurrentPin1	12	Int32	06:35:57.000	06:35:57.000	Good
2	OPC UA ...	NS0(Numeric...	CurrentPin2	0	Int32	06:35:40.000	06:35:40.000	Good
3	OPC UA ...	NS0(Numeric...	CurrentPin4	0	Int32	06:35:41.000	06:35:41.000	Good
4	OPC UA ...	NS0(Numeric...	MaxTemperatur...	35,7	Float	06:35:45.000	05:54:48.000	Good
5	OPC UA ...	NS0(Numeric...	MaxTemperatur...	35,7	Float	06:35:45.000	03:17:01.000	Good
6	OPC UA ...	NS0(Numeric...	MaxTemperatur...	35,7	Float	06:35:46.000	03:17:17.000	Good
7	OPC UA ...	NS0(Numeric...	VoltagePin1	23890	Int32	06:35:57.000	06:35:57.000	Good
8	OPC UA ...	NS0(Numeric...	VoltagePin2	-113	Int32	06:35:57.000	06:35:57.000	Good
9	OPC UA ...	NS0(Numeric...	VoltagePin4	-102	Int32	06:35:57.000	06:35:57.000	Good

8.6.3.6 Diagnostics

The OPC UA server provides nodes with diagnostic information. For example, the OPC UA client can read in the DiagnosticsPin1 node whether the device has detected an overcurrent on pin 1 of a port.

Node name	Node class	Access	Description
DiagnosticsPin1, DiagnosticsPin2, DiagnosticsPin4	Variable	Read	Diagnostics at pin 1, pin 2 or pin 4. The numeric value contains bit-coded information: <ul style="list-style-type: none"> • Bit 0: Short circuit, • Bit 1: Overload protection, • Bit 2: Over-temperature protection, • Bit 3: Overvoltage protection, • Bit 4: Overcurrent, • Bit 5: Undercurrent • Bit 0: Over-temperature • Bit 1: Under-temperature • Bit 2: Overvoltage • Bit 3: Undervoltage • Bit 4: Watchdog 0: Diagnostics not active 1: Diagnostics active

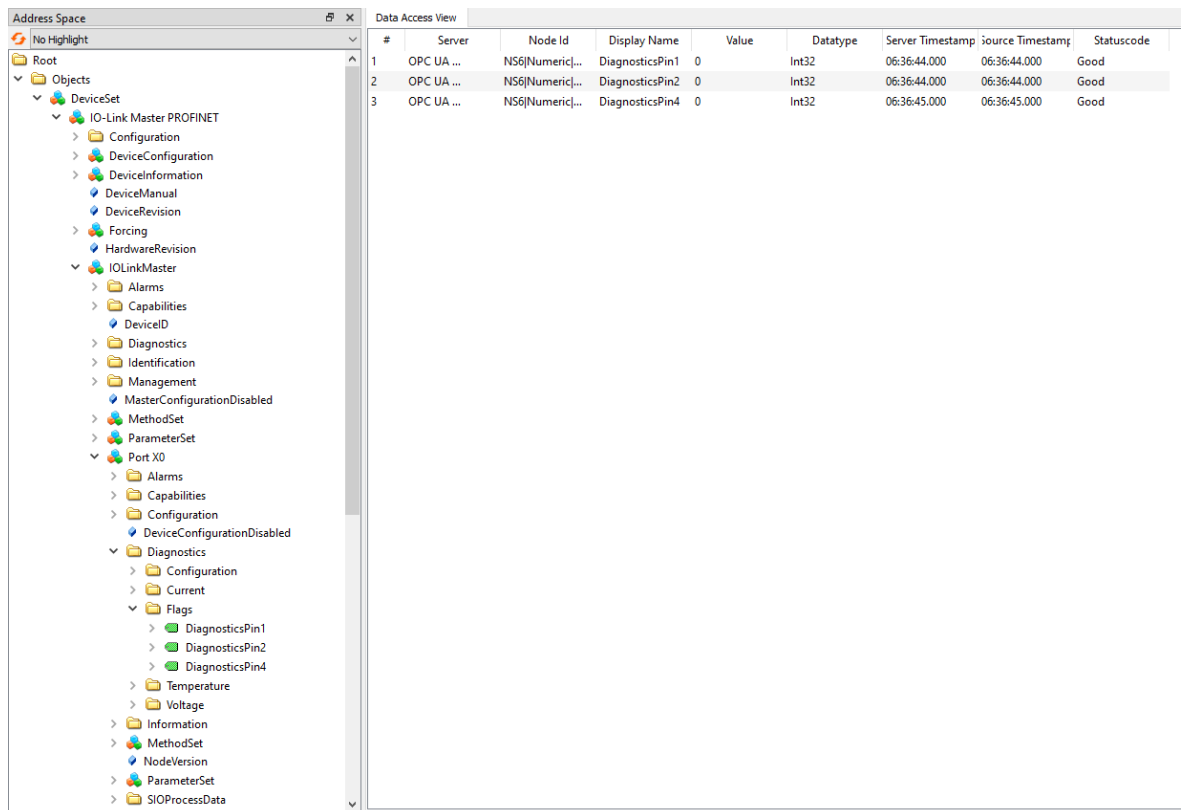

8.6.3.7 Statistics

The OPC UA server provides nodes with statistical information. For example, the OPC UA client can read the maximum measured current at pin 1 of a port in node **MaxCurrentPin1**.

Node name	Node class	Access	Description
Current			
MaxCurrentPin1, MaxCurrentPin2, MaxCurrentPin4	Variable	Read	Maximum current at pin 1, pin 2 or pin 4 since reset of value, unit: mA
MinCurrentPin1, MinCurrentPin2, MinCurrentPin4	Variable	Read	Minimum current at pin 1, pin 2 or pin 4 since reset of value, unit: mA
Temperature			
MaxTemperaturePin1, MaxTemperaturePin2, MaxTemperaturePin4	Variable	Read	Maximum temperature at pin 1, pin 2 or pin 4 since reset of value, unit: °C
MinTemperaturePin1, MinTemperaturePin2, MinTemperaturePin4	Variable	Read	Minimum temperature at pin 1, pin 2 or pin 4 since reset of value, unit: °C
Template			
MaxVoltagePin1, MaxVoltagePin2, MaxVoltagePin4	Variable	Read	Maximum voltage at pin 1, pin 2 or pin 4 since resetting the value, unit: mV
MinVoltagePin1, MinVoltagePin2, MinVoltagePin4	Variable	Read	Minimum voltage at pin 1, pin 2 or pin 4 since reset of value, unit: mV

#	Server	Node Id	Display Name	Value	Datatype
1	OPC UA Server	NS6 Numeric 34...	MaxCurrentPin1	109	Int32
2	OPC UA Server	NS6 Numeric 34...	MaxCurrentPin2	0	Int32
3	OPC UA Server	NS6 Numeric 34...	MaxCurrentPin4	0	Int32
4	OPC UA Server	NS6 Numeric 34...	MinCurrentPin1	104	Int32
5	OPC UA Server	NS6 Numeric 34...	MinCurrentPin2	0	Int32
6	OPC UA Server	NS6 Numeric 34...	MinCurrentPin4	0	Int32
7	OPC UA Server	NS6 Numeric 34...	MaxTemperaturePin1	43.7	Float
8	OPC UA Server	NS6 Numeric 34...	MaxTemperaturePin2	43.7	Float
9	OPC UA Server	NS6 Numeric 34...	MaxTemperaturePin4	43.7	Float
10	OPC UA Server	NS6 Numeric 34...	MinTemperaturePin1	42.2	Float
11	OPC UA Server	NS6 Numeric 34...	MinTemperaturePin2	42.2	Float
12	OPC UA Server	NS6 Numeric 34...	MinTemperaturePin4	42.2	Float
13	OPC UA Server	NS6 Numeric 34...	MaxVoltagePin1	23550	Int32
14	OPC UA Server	NS6 Numeric 34...	MaxVoltagePin2	-220	Int32
15	OPC UA Server	NS6 Numeric 34...	MaxVoltagePin4	-213	Int32
16	OPC UA Server	NS6 Numeric 34...	MinVoltagePin1	23525	Int32
17	OPC UA Server	NS6 Numeric 34...	MinVoltagePin2	-244	Int32
18	OPC UA Server	NS6 Numeric 34...	MinVoltagePin4	-233	Int32

8.6.3.8 NTP Client Configuration

The OPC UA server provides nodes for configuring the NTP client.

Node name	Node class	Access	Description
NtpClientServerIpAddress	Variable	Read/ write	<ul style="list-style-type: none"> IP address of the NTP server The NTP client uses the set IP address to get the time from an NTP server. The IP address must be converted to a decimal number. The calculation is described according to the table. The value 0 disables the function.
NtpClientServerIpAddressFallback	Variable	Read/ write	<ul style="list-style-type: none"> IP address of the NTP server (fallback) The optional additional IP address if the NTP server cannot be reached via the IP address in node NtpClientServerIpAddress. The IP address must be converted to a decimal number. The calculation is described according to the table. The value 0 disables the function.
NtpClientUpdateConfiguration	Variable	Write	Method for writing the nodes NtpClientServerIpAddress and NtpClientServerIpAddressFallback.

The following formula is used to convert the IP address to a decimal number. Starting from an IP address in A.B.C.D format:

$$((A * 256 + B) * 256 + C) * 256 + D = \text{IP address as a decimal number}$$

Example for IP address 192.53.103.108

8.6.3.9 OPC UA PC Client

The IO-Link master is equipped with an integrated web server. With an OPC UA client, you can communicate with the IO-Link master.

For test purposes, the UaExpert from Unified Automation GmbH can be used, for example: www.unifiedautomation.com

An OPC UA client can access the IO-Link master in read mode with “anonymous” authentication.

An OPC UA client can access the IO-Link master in read and write mode with the authentication “User name and password” if the user used has write permissions.

Connect to IO-Link Master

Prerequisites

- You have an OPC UA client.
- If you want to write to the IO-Link master: You know the username and password and have write access.
- You know the IP address of the IO-Link master.

Without a user name and password, you can access the IO-Link Master “anonymously” and read data.

Step-by-Step Instructions

Establish a connection to the IO-Link master:

- Start UaExpert
- Use File > New to create a new project.
- Use Server > Add to add a new server.

The Add Server dialog appears with the Discovery tab.

Discovery tab (default)

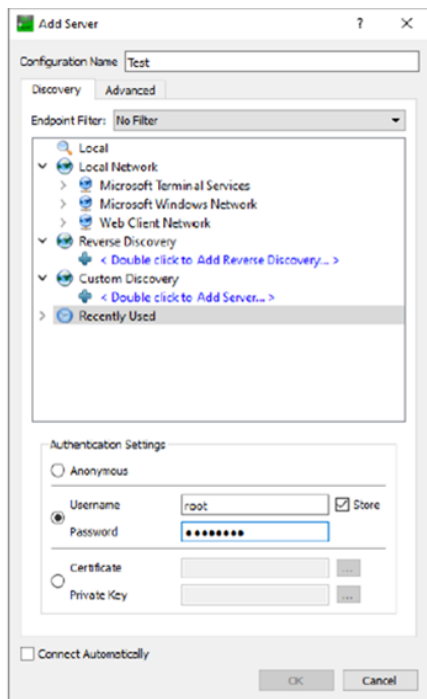

Advanced tab

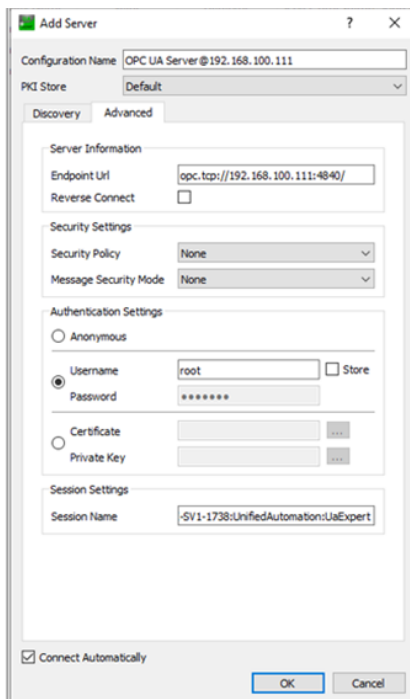

- In the Configuration name field, enter a name for your configuration, e.g. Test.
- Select the Advanced tab.
- In the Server Information section of the Advanced tab, enter the following in the Endpoint Url data field: `opc.tcp://<IP Address>:4840` For `<IP Address>`, enter the device's IP address.
- In the Authentication Settings area, select Username/Password if you want write access to the device or Anonymous if read access is sufficient.
- If you have selected the Username/Password option, enter your username and, if applicable, your password there.
- Then click OK.

In the project window, the UaExpert enters the server under Project >Servers, e.g. Test.

- Open the context menu of the server (Test) and select Connect.

The connection is established.

Prerequisites

- You have an OPC UA client.
- You know the username and password and have write access.
- You know the IP address of an NTP server.
- You have converted the IP address of this NTP server to a decimal number as described below.
- You have already established a connection to the MVK device.

Example of an NTP Server

NTP server `ptbtime1.ptb.de` of the Physikalisch-Technische Bundesanstalt in Braunschweig with the IP address `192.53.103.108`

Replacement NTP server (optional) of the NTP server `ptbtime2.ptb.de` of the Physikalisch-Technische Bundesanstalt in Braunschweig with the IP address `192.53.103.104`

Converting an IP address to a decimal number

The following formula is used to convert the IP address to a decimal number. Starting from an IP address in A.B.C.D format:

$$((A * 256 + B) * 256 + C) * 256 + D = \text{IP address as a decimal number}$$

Example for IP address `192.53.103.108`

$$((192 * 256 + 53) * 256 + 103) * 256 + 108 = 3224725356$$

Step-by-Step Instructions

- In the Address Space window, open the context menu:

Root> Objects> DeviceSet> [Device name] > Configuration> NtpClient>NtpClientUpdateConfiguration.

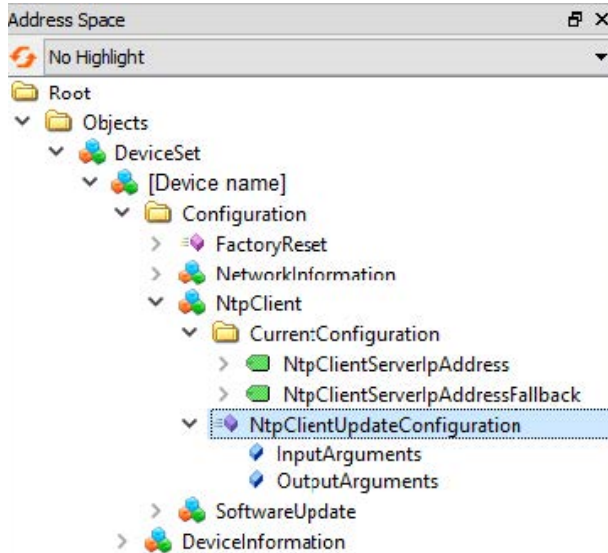

- Select Call from the context menu.

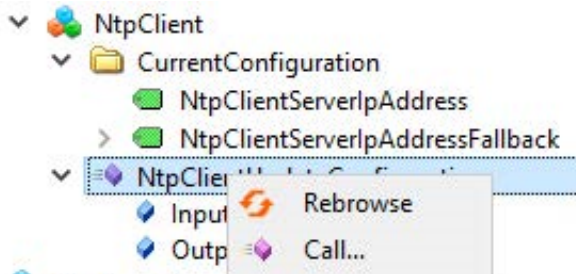

The Call **NtpClientUpdateConfiguration on NtpClient** dialog box is displayed:

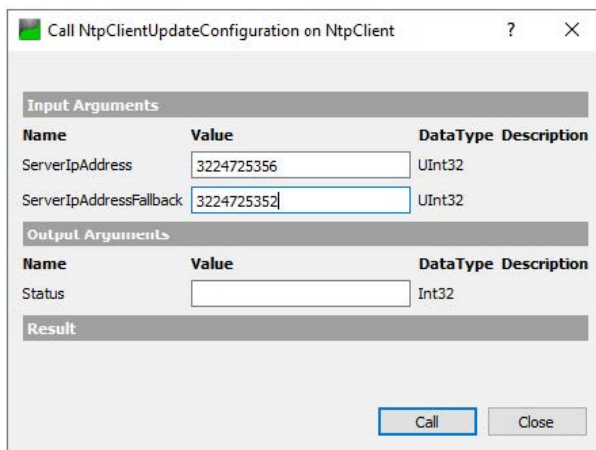

- In the **Input Arguments** area, enter the value 3224725356 in the **ServerIpAddress** input field for the IP address of the NTP server.
- In the **Input Arguments** area, enter the number 3224725352 in the **ServerIpAddressFallback** input field for the IP address of the replacement NTP server.
- Click **Call**.

If the function call was successful, the output field to the right of Status in the **Output Arguments** area displays the value 0. A green bar with the text "Succeeded" is displayed in the **Result** area.

The two variables ServerIpAddress and ServerIpAddressFallback are now set. The device obtains the current time from the time server via NTP and synchronizes its internal time.

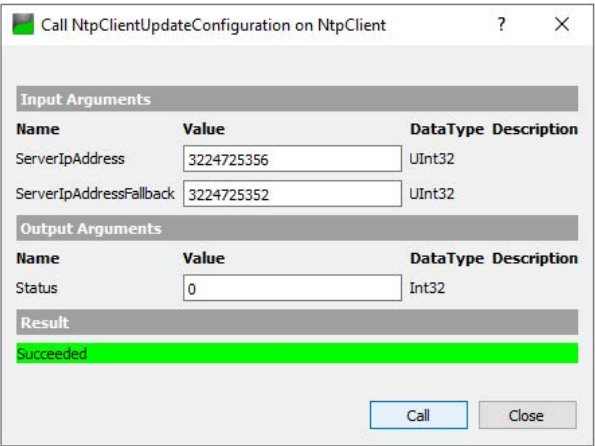

9 Operation

9.1 LED Display

The device has separate and clearly arranged displays:

- LED display for inputs and outputs
- LED display BUS
- LED display POWER
- Advanced LED displays

In order to assure unequivocal allocation of displayed information, the LEDs are correspondingly identified at the device's front panel. Displays include static illumination and blinking LEDs.

9.1.1 LED Assignment to Channel and Pin

A separate status display is assigned to each input and output.

- LED of channel 0X (X=port number) is assigned to pin 4.
- LED of channel 1X (X=port number) is assigned to pin 2.

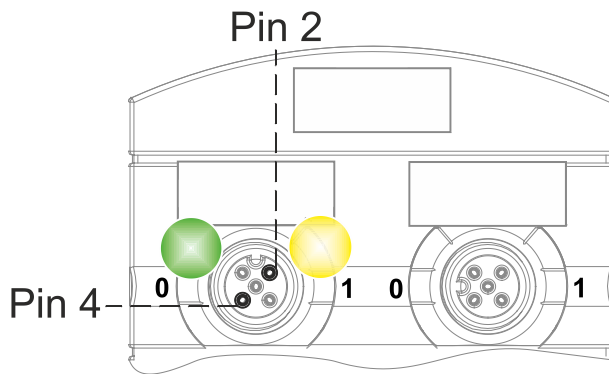

9.1.2 * Flashing Behavior:

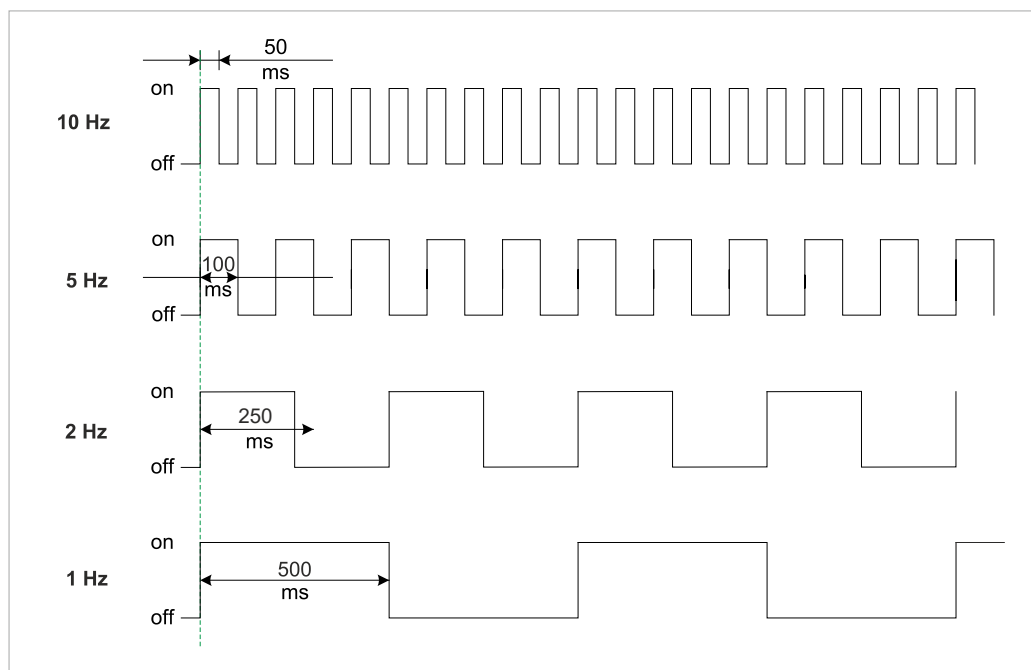

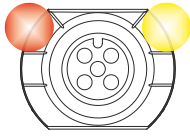

9.1.3 LED Display for Inputs and Outputs







A separate status display is assigned to each input and output.

Pin 2 Digital Input DI

Indicator	Status	Description
 Yellow	Continuous light	Fixed configuration: DI (NO) visible in process data. 24 V
 Red	Flashing 1 Hz	Overload/short-circuit of the sensor supply 24 V + Pin 1
 Red	Off	Pin 2 is not used or is switched off



Pin 2 Digital Output DO

Indicator	Status	Description
 Yellow	Continuous light	Fixed configuration: DO can be switched via process data 24 V
 Red	Continuous light	Overload/short circuit at pin 2
 Red	Flashing 1 Hz	Overload/short-circuit of the sensor supply 24 V + Pin 1
 Red	Off	Pin 2 is not used or is switched off

Input or Output Error



If an error occurs on an input or output, the corresponding LED on the M12 slot lights up red.

Pin 4 Digital Input DI







Indicator	Status	Description
 Yellow	Continuous light	Fixed configuration: DI (NO) visible in process data 24 V
 Red	Flashing 1 Hz	Overload/short-circuit of the sensor supply 24 V + Pin 1
 Red	Off	Pin 4 is not used or is switched off

Pin 4 Digital Output DO

Indicator	Status	Description
 Yellow	Continuous light	Fixed configuration: DO can be switched via process data 24 V

Indicator	Status	Description
 Red	Continuous light	Overload/short circuit at pin 4
 Red	Flashing 1 Hz	Overload/short-circuit of the sensor supply 24 V + Pin 1
 Red	Off	Pin 4 is not used or is switched off

Pin 4 IO-Link Mode



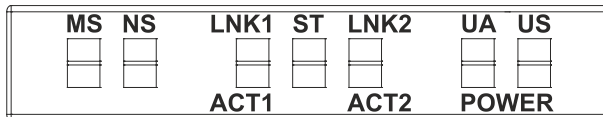

Indicator	Status	Description
 Green	Continuous light	IO-Link in status Operate.
 Green	Flashing 1 Hz	<ul style="list-style-type: none"> Device is not connected No communication with connected device.
 Green	Flashing 10 Hz	<ul style="list-style-type: none"> IO-Link in Pre-Operate status during data retention Validation failed. Incompatible IO-Link device connected.
 Red	Continuous light	Overload/short circuit at pin 4
 Red	Flashing 1 Hz	<ul style="list-style-type: none"> Validation failed. Incompatible IO-Link device connected for data storage. Data storage failed.
 Red	Off	IO-Link connection deactivated.



9.1.4 LED Display MS and NS



- NS shows the status of the bus system.
- MS shows the status of the PLC configuration.

LED Display MS

Indicator	Status	Description
 Green	Continuous light	Device in operation
 Green	Flashing 1 Hz	Standby: The device has not been configured.
 Green	Flashing 1 Hz	Self-test
 Red	Flashing 1 Hz	Self-test
 Red	Flashing 1 Hz	Serious repairable error.*

Indicator	Status	Description
 Red	Continuous light	Serious non-repairable error.
 Off		No supply power



INFORMATION

* Serious repairable error







An incorrect or inconsistent configuration is considered a serious repairable error.

LED Display Red

You can do this:

- Check IP address conflict.

LED Display NS

Indicator	Status	Description
 Green	Continuous light	<ul style="list-style-type: none"> • Connection to master present, • IP address is configured.
 Green	Flashing 1 Hz	<ul style="list-style-type: none"> • No connection to master. • IP address is configured.
 Green  Red	Flashing 1 Hz	Self-test
 Red	Flashing 1 Hz	At least one connection has timed out.
 Red	Continuous light	Duplicate IP address: the device has detected that its IP address is already in use.
 Off		<ul style="list-style-type: none"> • No supply power, • No IP address configured.

LED Display Red

You can do this:

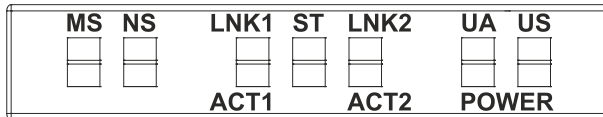

- Check IP address conflict.

9.1.5 LED Display LNK/ACT





- LNK/ACT (Link/Activity) show the status of the EtherCAT communication on the respective port.

LED Display LNK

LED display	LED status	Description
 Green	Continuous light	Connection to the network established.
 Off		No connection to network.

LED Display ACT

LED display	LED status	Description
 Yellow	Flashing	The device sends/receives Ethernet frames
 Off		The device is not sending/receiving Ethernet frames

LED Display Off

You can do this:



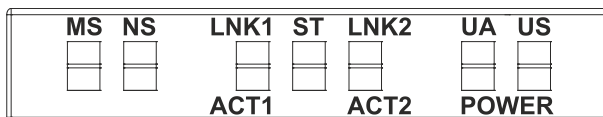

- Check the cable connections

9.1.6 LED Display Status



- ST – indicates the status of the entire device.

LED Display ST

LED display	LED status	Description
 Green	Continuous light	Connection to the network established.
 Green	Flashing 4 Hz	The process requested by the position of the rotary switch is carried out. Do not switch off the device.
 Red	Flashing 2 Hz	Invalid rotary switch position. The system will not start.
 Red	Continuous light	Initialization error. Error during device initialization. <ul style="list-style-type: none"> • HW problems, • No valid configuration, • No COM FW found • Rotary switch operation failed etc.

Red LED Flashes

You can do this:

- Select a valid position.
- Restart the device.



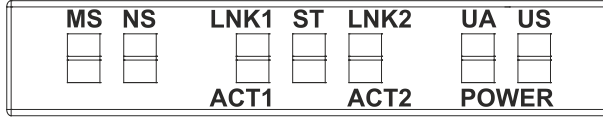

9.1.7 LED Display POWER US and UA







The power LEDs indicate the status of the supply voltages

- UA actuator voltage
- US operating voltage

LED Display POWER US

LED display	LED status	Description
 Green	Continuous light	$18\text{ V} \leq \text{US} \leq 30\text{ V}$ Trouble-free operation
 Red	Continuous light	$11\text{ V} \leq \text{US} \leq 18\text{ V}$ Undervoltage
 Red	Flashing 4 Hz	$\text{US} > 30\text{ V}$ Overvoltage
 Off	Off	$\text{US} < 11\text{ V}$ No voltage

LED Display POWER UA

LED display	LED status	Description
 Green	Continuous light	$18\text{ V} \leq \text{UA} \leq 30\text{ V}$ Trouble-free operation
 Red	Continuous light	$11\text{ V} \leq \text{UA} \leq 18\text{ V}$ Undervoltage
 Red	Flashing 4 Hz	$\text{UA} > 30\text{ V}$ Overvoltage
 Off	Off	$\text{UA} < 11\text{ V}$ No voltage



INFORMATION

At $\text{US} < 18\text{ V}$, fault-free operation is no longer guaranteed.

9.1.8 Advanced LED Display

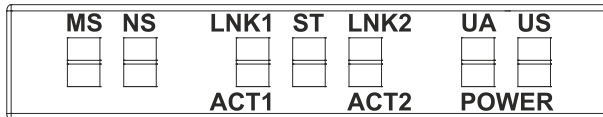

Identification of the Device

LED	Indicator	Status	Description
MS		Flashing	Identification of the device
NS	Green	1 Hz	
ST			
POWER UA			
POWER USF			

Update

LED	Indicator	Status	Description
MS		Cascading running light	Update transfer in progress
NS	Yellow		
ST			Update flashing
POWER UA	Red		
POWER USF			





Update

LED	Indicator	Status	Description
MS		Flashing 1 Hz alternating	Update transfer in progress
POWER UA	Yellow		
POWER US		Fast Flashing	Update flashing aborted
	Red		
	Red	Flashing 1 Hz alternating	Update not successful
ST			
	Off		





Recovery Firmware: System Startup

LED	Indicator	Status	Description
ST		Double flash (Double flash)	Recovery firmware: System startup
	Yellow		
NS			
POWER UA	Off		
POWER US			



Recovery Firmware: System Initialization

LED	Indicator	Status	Description
NS	 Green	Continuous light	Recovery firmware: System initialization
ST	 Yellow	Double flash (Double flash)	
MS	 Yellow	Flashing 1 Hz	
POWER UA POWER US	 Off		





Recovery Firmware: System Running



LED	Indicator	Status	Description
MS	 Green	Continuous light	Recovery firmware: System running
ST	 Yellow	Double flash (Double flash)	
POWER UA	 Yellow	Flashing 1 Hz	
POWER US	 Off		

Firmware Update: Initialization of the Transmission

LED	Indicator	Status	Description
MS POWER UA	 Green	Continuous light	Firmware Update: Initialization of the transmission
ST	 Yellow	Double flash (Double flash)	
POWER US	 Yellow	Flashing 1 Hz	

Firmware Update

LED	Indicator	Status	Description
ST	 Yellow	Double flash (Double flash)	Transferring the new firmware
MS POWER UA	 Yellow	Cascading running light	
POWER US	 Yellow	Flashing 1 Hz alternating	
	 Red	Cascading running light	Writing the new firmware

LED	Indicator	Status	Description
	 Red	Single flash (Single flash)	Writing aborted
	 Red	Flashing 1 Hz alternating	Writing firmware failed

9.2 Diagnostics

9.2.1 Diagnostic Structure in the Control System

Byte	Description	Value
0	Last octet of the device's IP address	Last octet of the device's IP address
1	IO-Link specification	0 = Default code 0x40 = IO-Link Master Event Code 0x41 = IO-Link Device Event Code 0x42 = wenglor IO-Link Device Event Code
2	Number of the master channel in which the error occurred	
3	Number of the device channel in which the error occurred	Only available if the IO-Link identifier (byte1) is set to the value 0x42.
4	ErrorCode Byte1	In the case of IO-Link, this is the LSB of the IO-Link error code, otherwise it is the global error code.
5	ErrorCode Byte2	In the case of IO-Link, this is the MSB of the IO-Link error code, otherwise this is the specific error code
6	Severity and active/inactive display	Bit 0: <ul style="list-style-type: none"> • 0 = Inactive diagnostics • 1 = Active diagnostics Bit 6 and 7: <ul style="list-style-type: none"> • 1 = Minor Fault • 2 = Major Fault • 3 = Information
7	Reserved	



9.2.2 Diagnostics in the Web Server

Diagnostic Monitoring

Another way to monitor the device's diagnostics is the diagnostics page of the built-in web server.

Display

The diagnoses are shown here in plain text as far as they are known:

1. Key: indicates which diagnostics is involved
2. Description: provides a more precise description of the error
3. Severity: differentiate between 3 categories
 -  Information
 -  Maintenance requirement
 -  Error

4. Type: This shows whether the diagnostics just occurred or has been rectified.

There are two types of diagnostics.

 Active

 Inactive

9.2.3 Diagnostic Value

9.2.3.1 Short Circuit Diagnostics

Global Error Code 0x01

Description	Value
Sensor Short Circuit	0x01
Actuator Warning	0x17
Actuator Short Circuit	0x18

9.2.3.2 Undervoltage Diagnostics

Global Error Code 0x02

Description	Value
Undervoltage Actuator Power Supply	0x28
No Voltage Actuator Power Supply	0x29
Undervoltage External Actuator Power Supply	0x2A
No Voltage External Actuator Power Supply	0x2B
Undervoltage Sensor Power Supply	0x32
No Voltage Sensor Power Supply	0x33
Undervoltage U1	0xD0
Undervoltage U2	0xD1

9.2.3.3 Overvoltage Diagnostics

Global Error Code 0x03

Description	Value
Overvoltage Actuator Power Supply	0x2C
Overvoltage External Actuator Power Supply	0x2D
Overvoltage Sensor Power Supply	0x34
Overvoltage U1	0xD4
Overvoltage U2	0xD5

9.2.3.4 General Diagnostics

Global Error Code 0x09

Description	Value
Error	0x00
PLC Connection Of Exclusive Owner Timed Out	0x59

9.2.3.5 Buffer-Overflow-Diagnostics

Global Error Code 0xFF

Description	Value
Overflow	0xFF

9.2.3.6 IO-Link-Master Diagnostics

IO-Link Identification 0x40

The meaning of the IO-Link event codes can be found:

- in the Profinet specification IO-Link Integration – Edition 2, Version 1.1 (IO-Link-Integration-for-PROFINET_Ed2_2832_V11_Feb20.pdf p. 45–46)
- in the IO-Link Interface and System Specification Version 1.1.3 June 2019 (IOL-Interface-Spec_10002_V113_Jun19.pdf S. 259-260).

9.2.3.7 IO-Link-Device Diagnostics

IO-Link Identification 0x41

Description	Value
Error	0x0000
General Malfunction	0x1000
Temperature Fault	0x4000
Ambient Temperature: General Error	0x4100
Ambient Temperature: Over-Run	0x4110
Ambient Temperature: Under-Run	0x4120
Device Temperature: General Error	0x4200
Device Temperature: Over-Run	0x4210
Device Temperature: Under-Run	0x4220
Outside Temperature: General Error	0x4300
Outside Temperature: Over-Run	0x4310
Outside Temperature: Under-Run	0x4320
Device Hardware Fault	0x5000
Component Malfunction	0x5010
Non Volatile Memory Loss	0x5011
Batteries Low	0x5012
General Power Supply Fault	0x5100
Fuse Blown/Open	0x5101
Primary Supply Voltage Over-Run	0x5110
Primary Supply Voltage Under-Run	0x5111
Secondary Supply Voltage Fault	0x5112
Device Supply: Voltage Under-Run U3	0x5113
Device Supply: Voltage Under-Run U4	0x5114
Device Supply: Voltage Under-Run U5	0x5115
Device Supply: Voltage Under-Run U6	0x5116
Device Supply: Voltage Under-Run U7	0x5117
Device Supply: Voltage Under-Run U8	0x5118
Device Supply: Voltage Under-Run U9	0x5119
Device Supply: Short Circuit	0x5151

Description	Value
Device Supply: Error In Periphery	0x5160
Device Controller: General Error	0x5200
Device Control Section: General Error	0x5300
Device Power Section: General Error	0x5400
Device Power Section: Error In Output Driver	0x5410
Device Power Section: Fuse Blown/Open	0x5450
Device Power Section: Fuse Blown/Open S1	0x5451
Device Power Section: Fuse Blown/Open S2	0x5452
Device Power Section: Fuse Blown/Open S3	0x5453
Device Power Section: Fuse Blown/Open S4	0x5454
Device Power Section: Fuse Blown/Open S5	0x5455
Device Power Section: Fuse Blown/Open S6	0x5456
Device Power Section: Fuse Blown/Open S7	0x5457
Device Power Section: Fuse Blown/Open S8	0x5458
Device Power Section: Fuse Blown/Open S9	0x5459
Error In Additional Device Communication	0x5500
Error In Device Communication Interface 2	0x5501
Device Software Fault	0x6000
Device Software: Reset (Watchdog)	0x6010
Device Software: Internal Fault	0x61000
Device Software: Dataset Error	0x6300
Loss Of Parameter	0x6310
Parameter Missing	0x6320
Parameter Missing	0x6321
Parameter Not Initialized	0x6330
Parameter Not Specific	0x6340
Parameter Changed	0x6350
Wire Break Of A Subordinate Device	0x7700
Wire Break Of Subordinate Device 1	0x7701
Wire Break Of Subordinate Device 2	0x7702
Wire Break Of Subordinate Device 3	0x7703
Wire Break Of Subordinate Device 4	0x7704
Wire Break Of Subordinate Device 5	0x7705
Wire Break Of Subordinate Device 6	0x7706
Wire Break Of Subordinate Device 7	0x7707
Wire Break Of Subordinate Device 8	0x7708
Wire Break Of Subordinate Device 9	0x7709
Wire Break Of Subordinate Device 10	0x770A
Wire Break Of Subordinate Device 11	0x770B
Wire Break Of Subordinate Device 12	0x770C
Wire Break Of Subordinate Device 13	0x770D
Wire Break Of Subordinate Device 14	0x770E
Wire Break Of Subordinate Device 15	0x770F
Short Circuit	0x7710
Ground Fault	0x7711
Communication Monitoring: General Error	0x8100
Process Data Monitoring: General Error	0x8110
Technology Specific Application Fault	0x8C00
Simulation Active	0x8C01

Description	Value
Process Variable Range Over-Run	0x8C10
Measurement Range Over-Run	0x8C20
Process Variable Range Under-Run	0x8C30
Maintenance Required - Cleaning	0x8C40
Maintenance Required - Refill	0x8C41
Maintenance Required - Wear And Tear	0x8C42

9.3 Acyclic IO-Link Device Accesses

IO-Link Device Parameter Object (Class Code 0x83)

The fieldbus device enables the configuration of the connected IO-Link devices with acyclic write and read access via the IO-Link Device Parameter Object (Class Code 0x83).

The IO-Link Device Parameter Object can be used to access parameters of an IO-Link device via ISDU (Index Service Data Unit). The object offers services that map CIP services to IO-Link services. An IO-Link port is addressed via the CIP instance of the "IO-Link Device Parameter Object".

9.3.1 Reading an IO-Link Device Index

Read ISDU Request

Read IO-Link device index

- To read an index of a connected IO-Link device, use the EtherNet/IP service Read_ISDU 75 (0x4B).
- To do this, send the service to the correct attribute of the IO-Link Device Parameter Object (Class Code 0x83).
- An attribute represents the IO-Link port to which the IO-Link device is connected.

Structure of a Read ISDU Service Request

Name	Value	Type	Description
CIP Service	75 (0x4B)		ISDU read service
CIP Class	131 (0x83)		IO-Link Device Parameter Object
CIP Instance	1 ... Number of available IO-Link Ports		Addresses the IO-Link Port the IO-Link device is connected to
CIP Data	Index	UINT	IO-Link ISDU object index
	Subindex	USINT	IO-Link ISDU Object Subindex

Read ISDU Response

Positive Response (CIP Status in Service Response == 0)

Name	Value	Type	Description
CIP Service	75 (0x4B)		ISDU read service
CIP Class	131 (0x83)		IO-Link Device Parameter Object
CIP Instance	1 ... Number of available IO-Link Ports		Addresses the IO-Link Port the IO-Link device is connected to
CIP Data	ISDU Data	ARRAY of BYTE	IO-Link object data retrieved from the IO-Link device. Maximum number of bytes: 0 – 232

Negative Response (CIP Status in Service Response != 0)

Name	Value	Type	Description
CIP Service	75 (0x4B)		ISDU read service
CIP Class	131 (0x83)		IO-Link Device Parameter Object
CIP Instance	1 ... Number of available IO-Link Ports		Addresses the IO-Link Port the IO-Link device is connected to
CIP Data	The structure of the error codes can be found CIP Status Codes [► 79]	UINT	IO-Link Master Error
		USINT	IO-Link Device Error
		USINT	IO-Link Device Additional Error

9.3.2 Writing an IO-Link Device Index

Write ISDU Request

Write IO-Link Device Index

- To write an index of a connected IO-Link device, use the EtherNet/IP service Write_ISDU 76 (0x4C).
- To do this, send the service to the correct attribute of the IO-Link Device Parameter Object (Class Code 0x83).
- An attribute represents the IO-Link port to which the IO-Link device is connected.

Structure of a Write ISDU Service Request

Name	Value	Type	Description
CIP Service	76 (0x4C)		ISDU write service
CIP Class	131 (0x83)		IO-Link Device Parameter Object
CIP Instance	1 ... Number of available IO-Link Ports		Addresses the IO-Link Port the IO-Link device is connected to
CIP Data	Index	UINT	IO-Link ISDU object index
	Subindex	USINT	IO-Link ISDU Object Subindex
	Data	ARRAY of Bytes	Data that shall be written to IO-Link device. Maximum number of bytes: 0 – 232

Write ISDU Response

Positive Response (CIP Status in Service Response == 0)+

The positive response to this service does not contain CIP data.

Name	Value	Type	Description
CIP Service	76 (0x4C)		ISDU write service
CIP Class	131 (0x83)		IO-Link Device Parameter Object
CIP Instance	1 ... Number of available IO-Link Ports		Addresses the IO-Link Port the IO-Link device is connected to
CIP Data	The positive response to this service does not hold any CIP Data (Number of bytes: 0).		

Negative Response (CIP Status in Service Response != 0)

Name	Value	Type	Description
CIP Service	76 (0x4C)		ISDU write service
CIP Class	131 (0x83)		IO-Link Device Parameter Object
CIP Instance	1 ... Number of available IO-Link Ports		Addresses the IO-Link Port the IO-Link device is connected to

Name	Value	Type	Description
CIP Data	The positive response to this service does not hold any CIP Data (Number of bytes: 0).	UINT	IO-Link Master: Error code
		USINT	IO-Link Device: Error code
		USINT	IO-Link Device: Additional error code

9.3.3 CIP Status Codes

CIP Error Codes

The following table gives a brief overview of which CIP status code can be returned when accessing the “IO-Link Device Parameter Object” via a CIP service. The table is not intended to be exhaustive.

CIP Status	Description
0 (0x00)	Success. Service was successfully performed.
5 (0x05)	Path destination unknown. Addressed CIP Class or CIP Instance is not known.
8 (0x08)	Service not supported. The requested service is not implemented or was not defined for this Object Class/Instance.
19 (0x13)	Not enough data. The service did not supply enough data to perform the specified operation.
20 (0x14)	Attribute not supported. The attribute specified in the request is not supported.
21 (0x15)	Too much data. The service supplied more data than was expected.
30 (0x1E)	An embedded service resulted in an error. The IO-Link specific error codes within the CIP response data might provide more information about what went wrong.

10 Web Server

The wenglor web server is a graphical tool with which you can quickly and intuitively obtain information about the device.

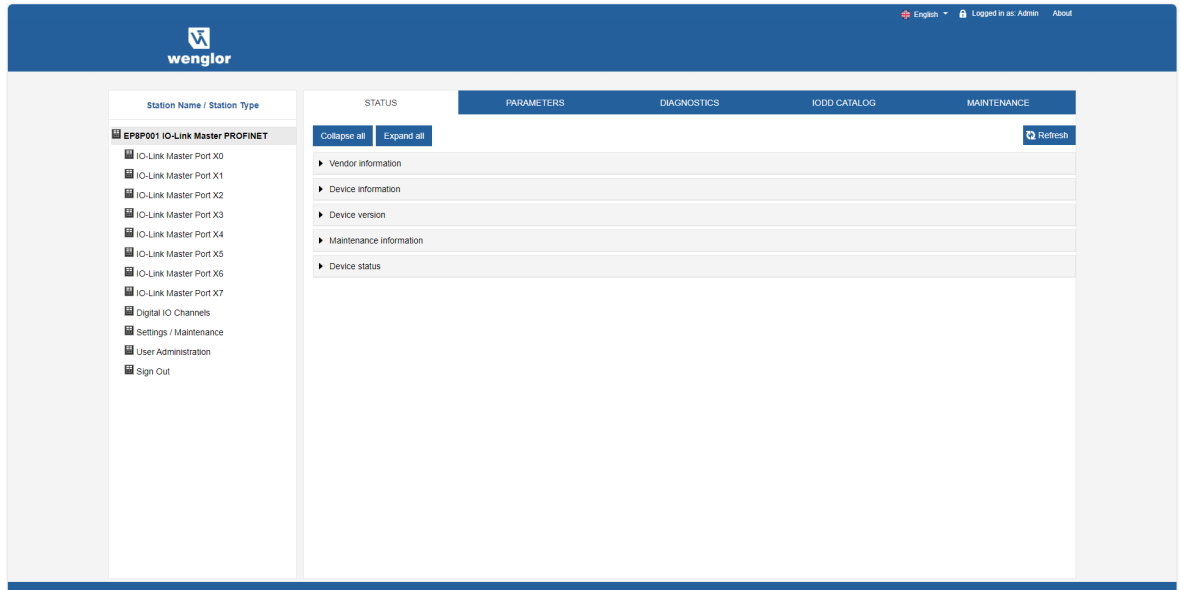

The devices mentioned in the screenshots serve as examples.

10.1 Start Web Server

Prerequisites

Prerequisite for a correct graphical representation of the web server:

The following browsers with HTML5 and ES5 are supported by:

- Mozilla Firefox
- Microsoft Edge
- Google Chrome

To start the web server, proceed as follows:

- Start the web browser.
- Enter the IP address of the device in the web browser. The start screen of the web server is displayed.

10.2 Access and Login

Username and Password

Username and password at first startup

1. At first start-up, enter the login details for user name and password:

- a) User name <admin>
- b) Password <private>

Second Click on Login.

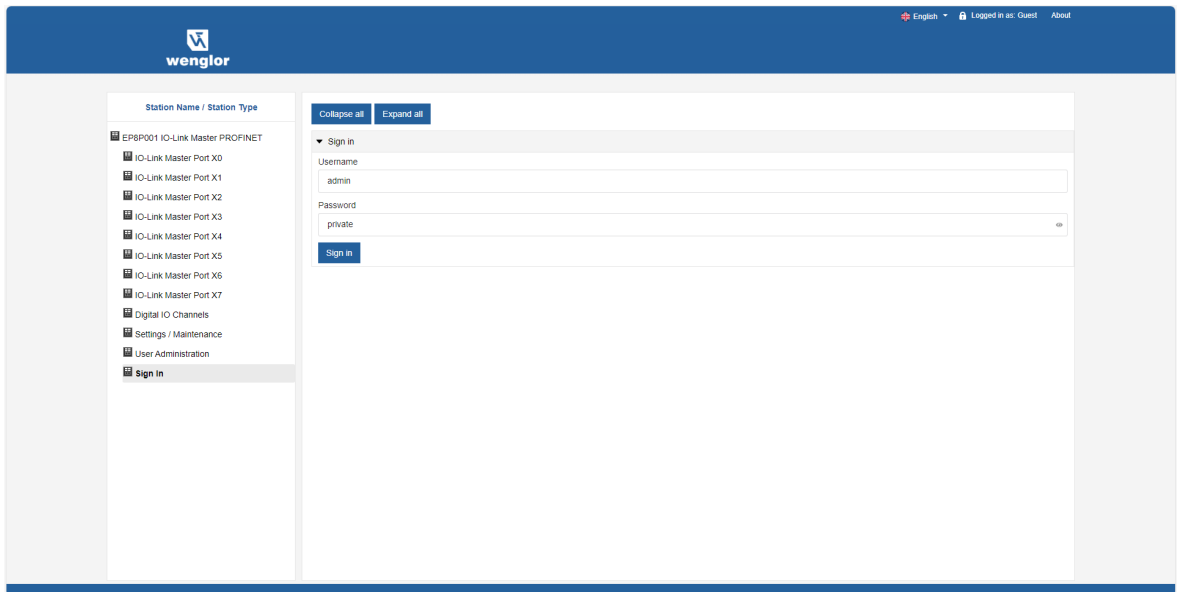

Change Password



INFORMATION

Ensure data security.

→ Change user name and password after the first login and after each factory reset.

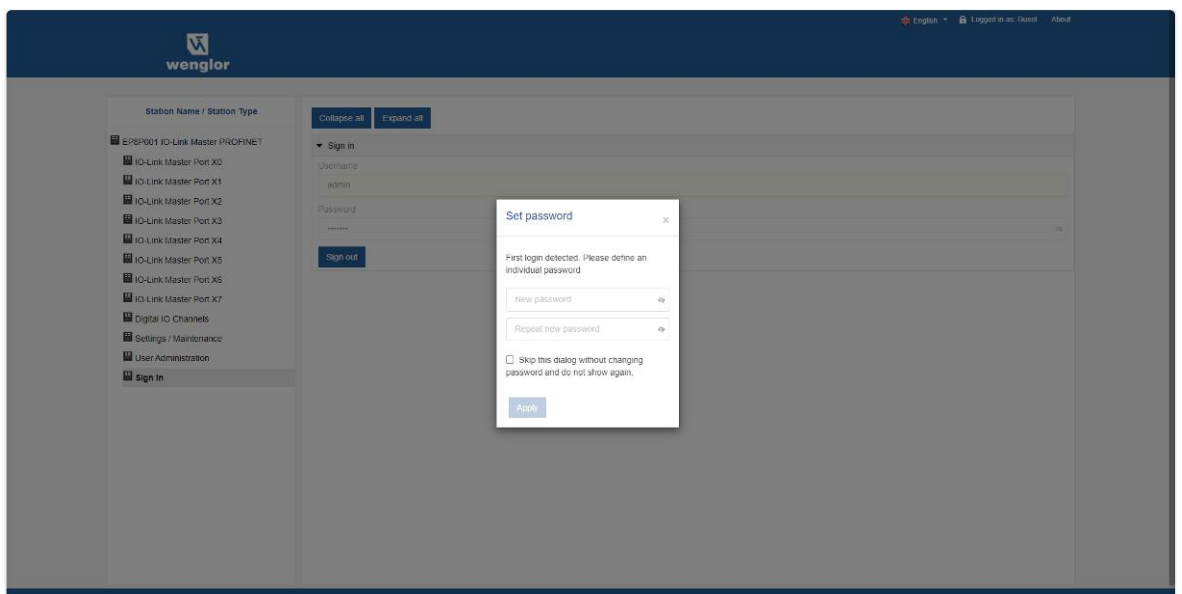

10.3 Start Screen

Operating Ranges

The web server is divided into 4 operating areas.

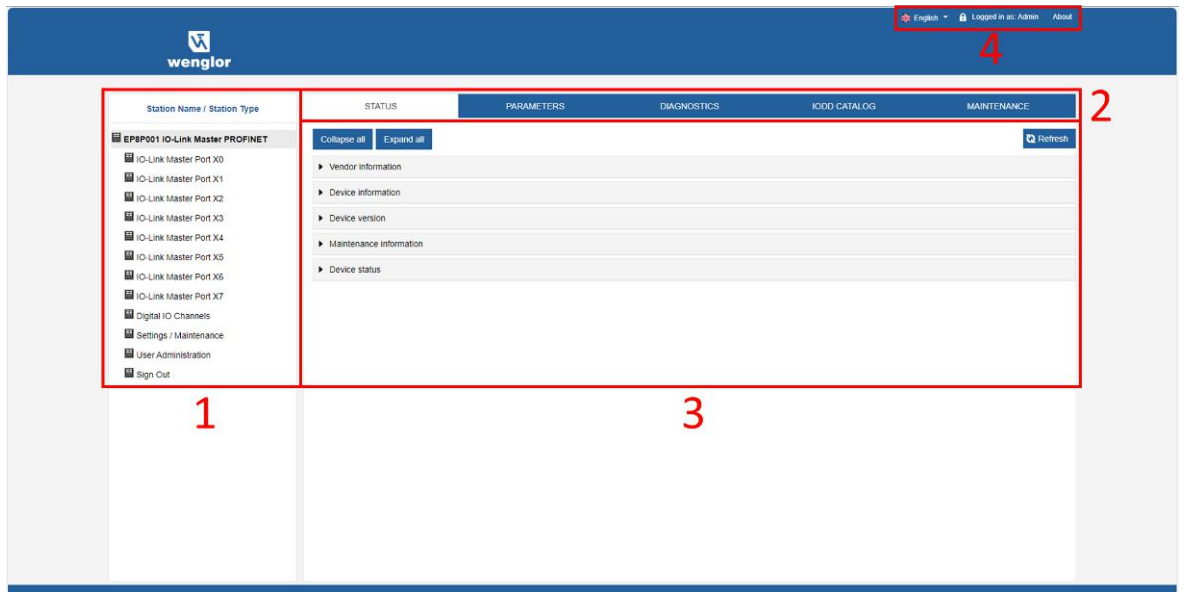

1. **System tree**

This shows the device and available sub-functions.

2. **Menu bar**

The menu bar can be used to switch between the different pages of the device or the subfunction. In addition, the white highlighting shows which page you are currently on.

3. **Page content**

This area displays the content of the selected page.

4. **Header bar**

Language and interface settings, system information.

10.4 Menu Bar

The first line of the system tree displays the device with article number and product name.

The menu bar contains the following clickable menu items:

- STATUS
- PARAMETER
- DIAGNOSTICS
- IODD CATALOG
- MAINTENANCE

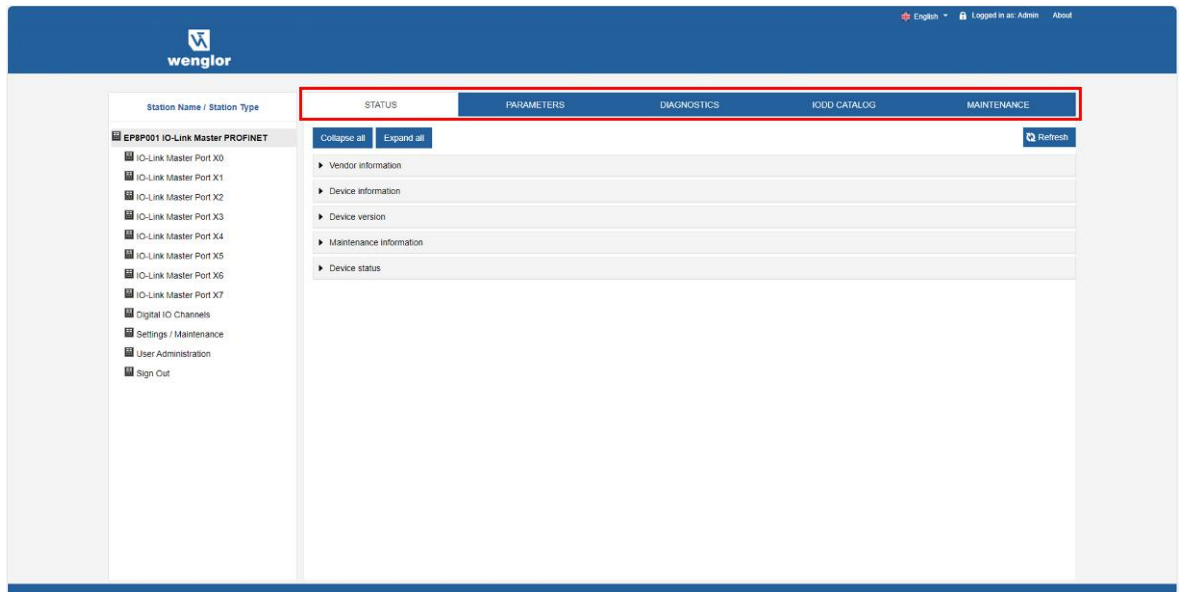

10.4.1 STATUS Menu

The “Status” menu item contains the following sub-items:

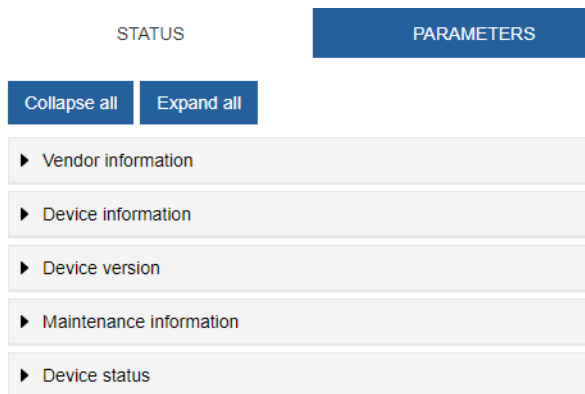

Manufacturer Information

“Manufacturer information” shows the following information:

Parameter name	Meaning
Manufacturer name	Fixed manufacturer data
Manufacturer address	Fixed manufacturer data
Manufacturer phone	Fixed manufacturer data
Manufacturer URL	Manufacturer website

Device Information

“Device information” displays the following information:

Parameter name	Meaning
Order Number	Article number of the device
Hardware name	Fixed article designation of the device
Software name	Device fieldbus designation
Software number	Serial number of the device

Device Version

“Device version” shows the following information:

Parameter name	Meaning
Hardware version	Version of hardware
Software version	Current software version in the device
Website version	Current version of the web server in the device

Maintenance Information



INFORMATION

The maintenance information can only be read here. The fields are entered or changed via “Settings/Maintenance → Maintenance information”.

“Maintenance information” displays the following information:

Parameter name	Meaning
Name	Device name, free text
Installation location	Place name, free text
Contact information	Contact, free text
Description	Description, free text
Last maintenance date (yyyy-mm-dd)	Free date entry
Next maintenance date (yyyy-mm-dd)	Free date entry

IO-Link Device Information

Parameter name	Meaning
1L voltage [V]	Display of sensor voltage in volts
1L current [A]	Display of sensor voltage in amperes
2L voltage [V]	Display of sensor voltage in volts
2L current [A]	Display of sensor voltage in amperes
Temperature [°C]	Display of the device temperature in Celsius
Total operating time [hh:mm:ss] Number of starts	Operating time since the device was switched on
Number of starts	Number of device restarts

10.4.2 PARAMETERS Menu

The “Parameters” menu item contains the following sub-items:

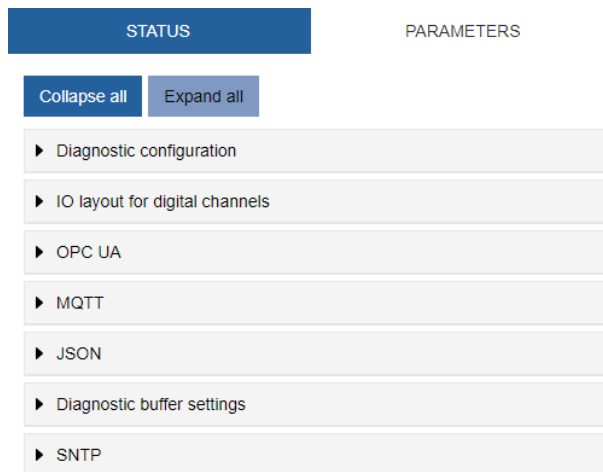

OPC UA

Users with Admin and Operator rights can change settings and enter the OPC UA port number. Guest users have read access.

OPC UA displays the following information:

Parameter name	Meaning
Enable OPC UA Server	OPC-UA server on the module active/passive
Allow OPC UA clients to write ISDU data	OPC-UA client may write ISDU data (Indexed Service Data Unit) to the module on the IO-Link master
Allow OPC UA clients to write PDO data	OPC-UA client is allowed to write PDO (process data objects) to the assembly on the IO-Link master
OPC UA port number	Display/definition of OPC-UA port

MQTT

Users with admin and operator rights can change settings and enter the IP address of the MQTT server. Guest users have read access.

“MQTT” shows the following information:

Parameter name	Meaning
Activate MQTT	MQTT client on the assembly active/passive
MQTT server IP address	IP address of the MQTT server
MQTT Client ID	Read/Write MQTT Client ID
Client head topic	Reading/writing an MQTT topic
Topic for system	Reading/writing an MQTT topic

JSON

Users with admin and operator rights can enable and disable JSON. Guest users have read access.

“JSON” shows the following information:

Parameter name	Meaning
Activate JSON	JSON interface on the module active/passive

10.4.3 DIAGNOSTICS

The “Diagnostics” menu item displays the incoming and outgoing alarms of the master.

The menu shows an overview of the diagnostic messages.

Depending on the setting in the “Please select an entry” drop-down menu, the following diagnostics of the device are displayed:

- Enabled
- All diagnoses pending at the time of the web server call.
- All diagnoses that no longer exist are not displayed.
- History
- All diagnoses no longer available from the residual diagnostic memory are displayed.
- More than 40 diagnoses in memory. The latest diagnostics overwrites the oldest in the memory.

The screenshot shows the Wenglor web interface. The top navigation bar includes the Wenglor logo and user information (English, Logged in as: Admin, About). The main content area has a sidebar on the left with a tree view of navigation items: Station Name / Station Type, EP8E001 IO-Link Master PROFINET, IO-Link Master Port X0 through X7, Digital IO Channels, Settings / Maintenance, User Administration, and Sign Out. The main area has tabs for STATUS, PARAMETERS, DIAGNOSTICS (selected), IODD CATALOG, and MAINTENANCE. Below the tabs is a dropdown menu labeled "Please select an entry:" with "Active" selected. A "Refresh" button is to the right. Below this is a table with columns: Key, Description, Channel, Severity, Type, and Time. The table contains one row: IO-Link master event, No Device (communication), 0, Fault, Occured, 0006.13.15.14.

Key	Description	Channel	Severity	Type	Time
IO-Link master event	No Device (communication)	0	Fault	Occured	0006.13.15.14

10.4.4 IODD CATALOG Menu

In the “IODD CATALOG” menu item, users can manage the IODD files on the device.

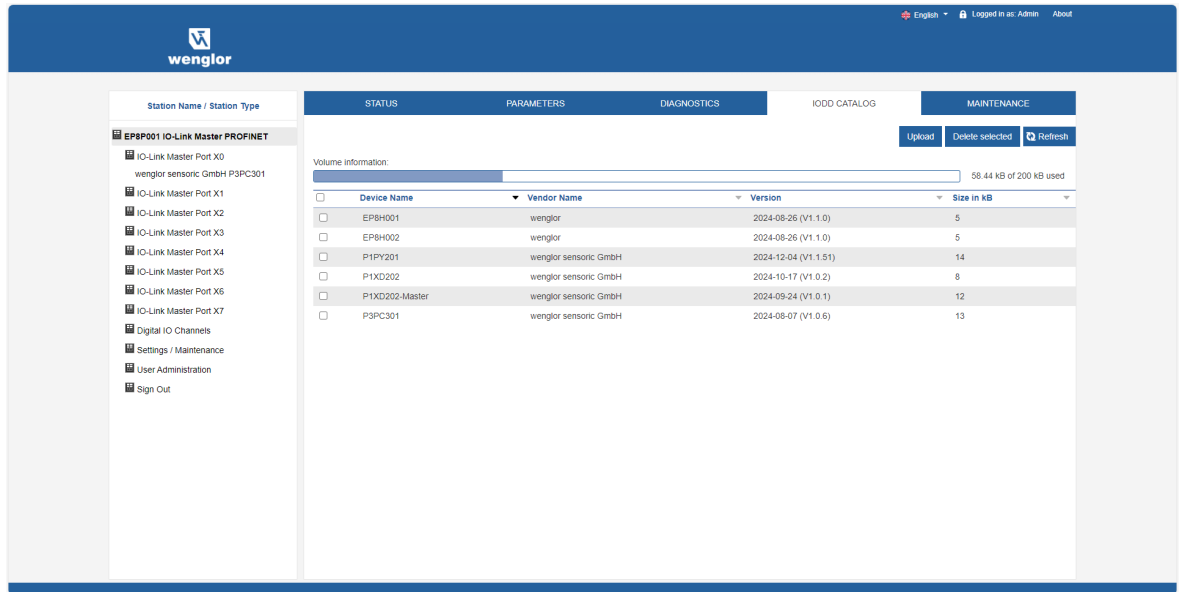

10.4.5 MAINTENANCE Menu

Users with administrator and operator rights can delete the diagnostic memory in the “Maintenance” menu item.

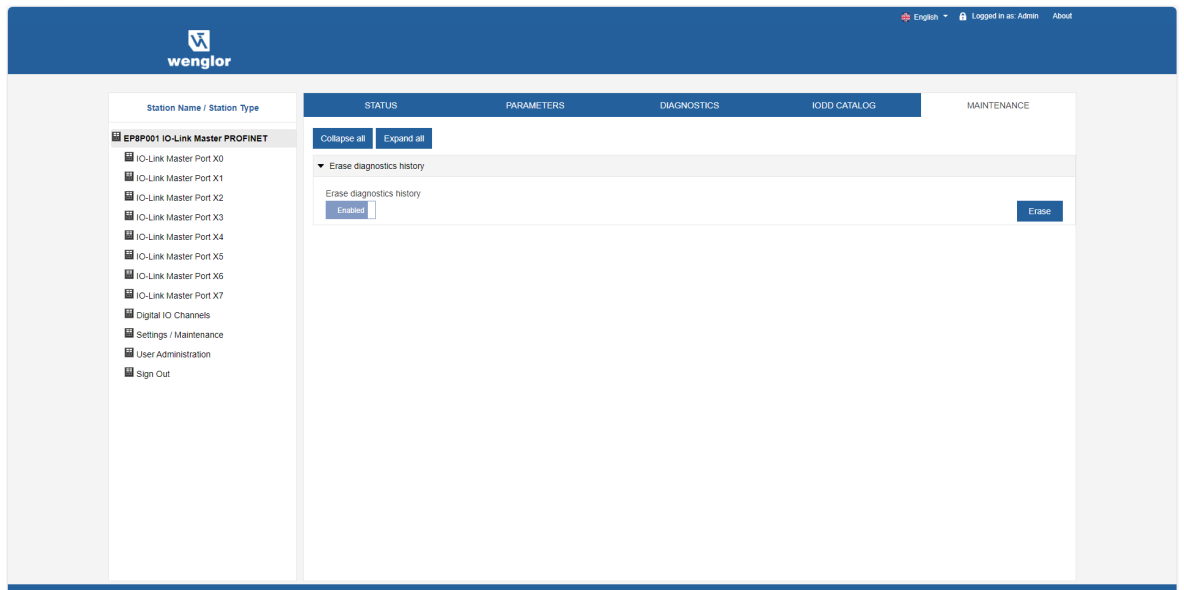

10.5 IO-Link Master Port

The system tree displays 8 IO-Link master ports (X0 ... X7), which can be selected individually. Depending on the user role, information can be read or functions configured here. When IO-Link communication is active, the IO-Link device name automatically appears under the relevant port.

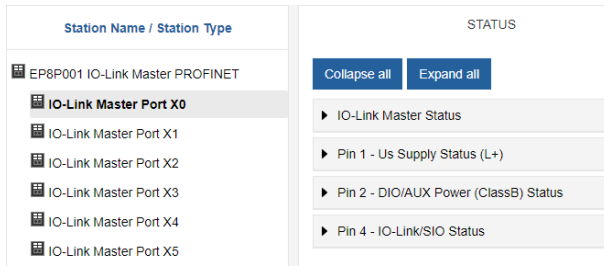

10.5.1 STATUS Menu

The IO-Link master status is displayed here in the Status menu.

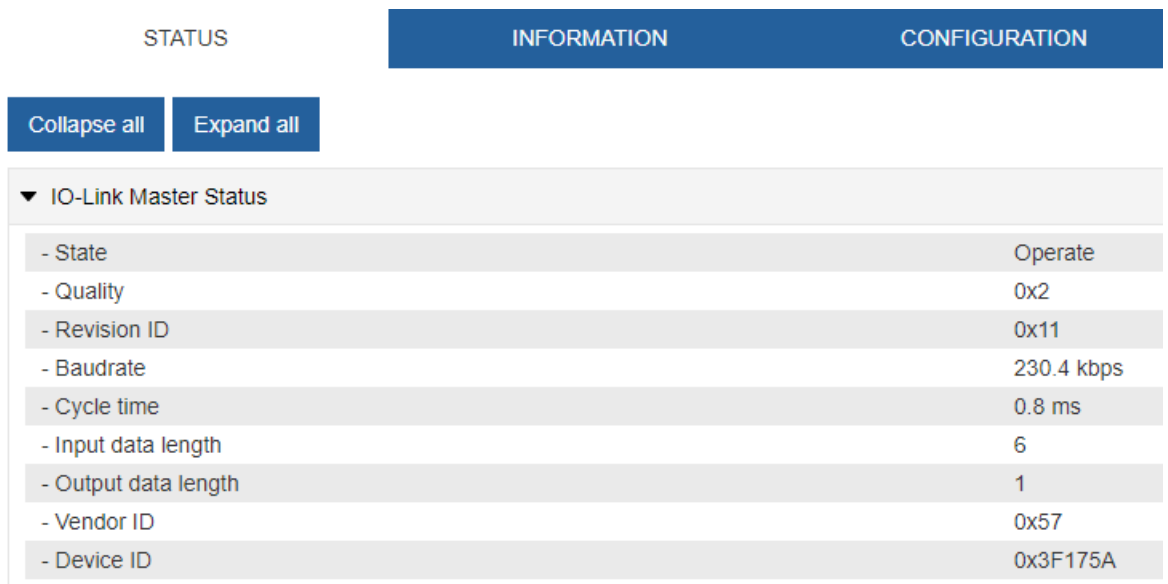

If pin 4 is in IO-Link mode, all relevant IO-Link data including the I/O bytes of the device are displayed (see Fig. 10-10: “IO-Link Master Port – IO-Link Master Status”).

If pin 4 is in operation without an IO-Link device connected, it is displayed that no device is connected.

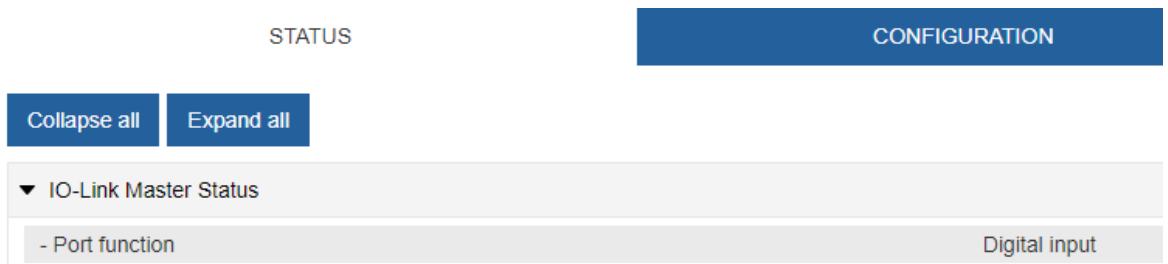

For example, if pin 4 is configured as a digital input, this is also displayed here (see Fig. 10-11: “IO-Link master port – IO-Link master status in digital mode”).

Possible status displays:

- Status: Deactivated
- Status: Digital input
- Status: Digital output

Port Status – Pin 1

“Port Status – Pin 1” displays the following information

Parameter name	Meaning
Temperature [°C]	Temperature in degrees Celsius
Voltage [V]	Voltage in volts
Current [A]	Current in amps
Status	Status of pin

Port Status – Pin 2

“Port Status – Pin 2” displays the following information

Parameter name	Meaning
Temperature [°C]	Temperature in degrees Celsius
Voltage [V]	Voltage in volts
Current [A]	Current in amps
Status	Status of pin

Port Status – Pin 4

“Port Status – Pin 4” displays the following information

Parameter name	Meaning
Temperature [°C]	Temperature in degrees Celsius
Voltage [V]	Voltage in volts
Current [A]	Current in amps
Status	Status of pin

10.5.2 INFORMATION Menu

The “Information” menu item contains the following sub-items:

STATUS INFORMATION CONFIGURATION IO-LINK PARAMETERS

Collapse all Expand all

▼ IO-Link Device Information

- Min cycle time	0.8 ms
- Function ID	0
- Number of profile IDs	4
- Vendor name	wenglor sensoric GmbH
- Vendor text	the innovative family
- Product name	P3PC301
- Product ID	P3PC301
- Product text	Laser Distance Sensor Triangulation
- Serial number	750073271
- Hardware revision	V01.00.00
- Firmware revision	V01.00.00

IO-Link Device Information

The technical data and manufacturer information of a connected and active IO-Link device on the corresponding master port are displayed here.

“IO-Link Device Information” displays the following information:

Parameter name	Meaning
Min. cycle time	Minimum process cycle time of the IO-Link device
Function-ID	Function ID of the IO-Link device
Number of profile IDs	Number of profiles supported by the IO-Link device
Manufacturer name	Manufacturer name of the IO-Link device
Manufacturer text	Manufacturer text of the IO-Link device
Product name	Product name of the IO-Link device
Product ID	Article number of the IO-Link device
Product text	Additional description of the IO-Link device
Serial number	Serial number
Hardware status	Hardware status
Firmware status	Firmware status

10.5.3 CONFIGURATION Menu

In the “Configuration” menu item of the selected IO-Link port, the setting of pin 1, pin 2 and pin 4 on the selected port is displayed and can be configured there.

Users with Operator and Admin rights can set the functions and behavior of Pin 1, Pin 2 and Pin 4.

Users with service and maintenance rights have read access.

Pin 4 can be deactivated or configured as IO-Link master, input or output.

Pin 2 can be deactivated or configured as input, output or DIO in “Automatic Mode”.

If pin 2 or pin 4 is configured as an input, the digital input filters can be set individually.

STATUS	CONFIGURATION	PROCESS DATA						
Collapse all Expand all		Save Refresh						
<ul style="list-style-type: none"> Port Functions - Pin 4 Port Functions - Pin 2 <table border="1"> <tr> <td>Port function</td> <td>Automatic mode (DIO)</td> </tr> <tr> <td>Digital input signal filter</td> <td>No digital input filter</td> </tr> <tr> <td>Output current limitation for DIO</td> <td> No digital input filter 1ms 3ms 5ms 10ms 15ms </td> </tr> </table> Port Functions - Pin 1 Port Diagnostics IODD Assignment 			Port function	Automatic mode (DIO)	Digital input signal filter	No digital input filter	Output current limitation for DIO	No digital input filter 1ms 3ms 5ms 10ms 15ms
Port function	Automatic mode (DIO)							
Digital input signal filter	No digital input filter							
Output current limitation for DIO	No digital input filter 1ms 3ms 5ms 10ms 15ms							

10.5.4 IO-LINK PARAMETERS Menu

This menu item can be used to read and write the ISDU (Index Service Data Unit) of the device during IO-Link operation. This primarily allows an IO-Link device to be evaluated or parameterized without a control system. The input can be made in both Hex and ASCII format.



INFORMATION

Follow the instructions in the IO-Link device manufacturer's manual.

Users with maintenance and admin rights can write ISDU values. Users with service rights have read access.

STATUS	INFORMATION	CONFIGURATION	IO-LINK PARAMETERS	PROCESS DATA								
Collapse all Expand all		Save Refresh										
<ul style="list-style-type: none"> ISDU Communication <table border="1"> <tr> <td>Index</td> <td>00</td> </tr> <tr> <td>Subindex</td> <td>00</td> </tr> <tr> <td>Input data</td> <td>00</td> </tr> <tr> <td>Format</td> <td>Hex</td> </tr> </table> 					Index	00	Subindex	00	Input data	00	Format	Hex
Index	00											
Subindex	00											
Input data	00											
Format	Hex											
Read Write												
<small>* All values are in hexadecimal without spaces.</small>												
Clear history												

10.5.5 PROCESS DATA Menu

In the "Process data" menu item, the current process data of the connected IO-Link device is displayed continuously if pin 4 of the corresponding port has been configured as an IOL port. Example: Port X2: Pin 4 (IOlink Autostart) and Pin 2 (Digital output static on).

STATUS	INFORMATION	CONFIGURATION	IO-LINK PARAMETERS	PROCESS DATA
Collapse all Expand all				
▼ Process Data				
Pin 4 IOL Input				00,07,0b,d0,fa,03
Pin 4 IOL Output				00
Force Pin 4 IOL Output Data	Write	Disable Forcing		
Pin 2 DO				1
Pin 2 DI				1
Format				Hexadecimal

This menu item displays the current statuses of the digital inputs. Example: Port X1: Pin 4 (DI) and Pin 2 (DI)

STATUS	CONFIGURATION	PROCESS DATA
Collapse all Expand all		
▼ Process Data		
Pin 4 DI	1	
Pin 2 DO	1	
Pin 2 DI	1	
Format	Hexadecimal	

10.6 Digital IO Channels / IO Overview

In the “Configuration” menu of the selected IO-Link port, the setting of pin 2 and pin 4 on the selected port is displayed. Outputs can be set under certain conditions.

10.6.1 Input Data

Each user can observe the digital states of the inputs configured on the device.

IO OVERVIEW	
Collapse all Expand all	
▼ Input data	
Port X1 Pin 4 (Channel 01)	Enabled
Port X2 Pin 4 (Channel 02)	Enabled
Port X3 Pin 4 (Channel 03)	Enabled
Port X4 Pin 4 (Channel 04)	Enabled
▶ Allow forcing outputs	
▶ Output data	

10.6.2 Output Data

Allow Outputs Setting

Users with Admin, Service and Maintenance rights can allow setting of outputs in this menu.

The right is only granted if the device is not in an active fieldbus connection with the control. The control has priority.

The screenshot shows the 'IO OVERVIEW' page with a 'Collapse all' and 'Expand all' button at the top. Below, there are sections for 'Input data', 'Allow forcing outputs', and 'Output data'. The 'Allow forcing outputs' section is expanded, showing the text 'Allow forcing of output values when there is no data exchange with PLC.' and a toggle switch set to 'Enabled'. An 'Allow' button is located to the right of the toggle.

Setting of Output Data

Guest users are not allowed to set the outputs.

All other users (admin, operator, maintenance) are allowed to set the outputs.

As soon as the user (admin, operator, maintenance) logs out, the outputs go to “0”.

As soon as a fieldbus is actively working with the device, the outputs go to “0” and then assume the status that they receive from the controller.

The screenshot shows the 'IO OVERVIEW' page with the 'Output data' section expanded. It lists eight ports from Port X0 to Port X7, each with a corresponding 'Enabled' or 'Disabled' toggle switch. Port X0 and X1 are 'Enabled', while Ports X2 through X7 are 'Disabled'. An 'Allow' button is visible at the top right of the 'Allow forcing outputs' section.

10.7 Settings / Maintenance

10.7.1 DEVICE CONFIGURATION Menu

In Profinet, the address is usually assigned by the control system using the DCP. Therefore, only the IP setting can be read in the web server.

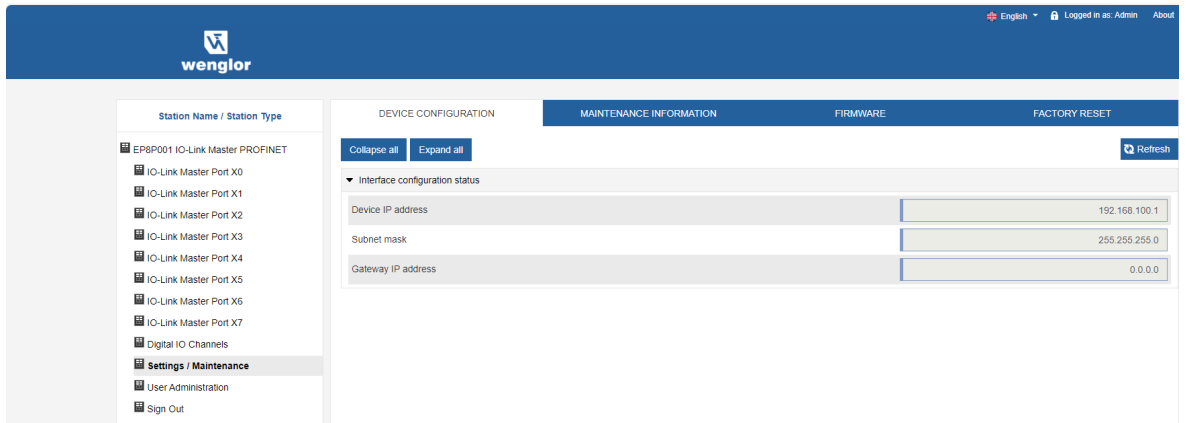

10.7.2 MAINTENANCE INFORMATION Menu

The maintenance information appears in the device in the menu item “Status” and submenu “Maintenance information”.

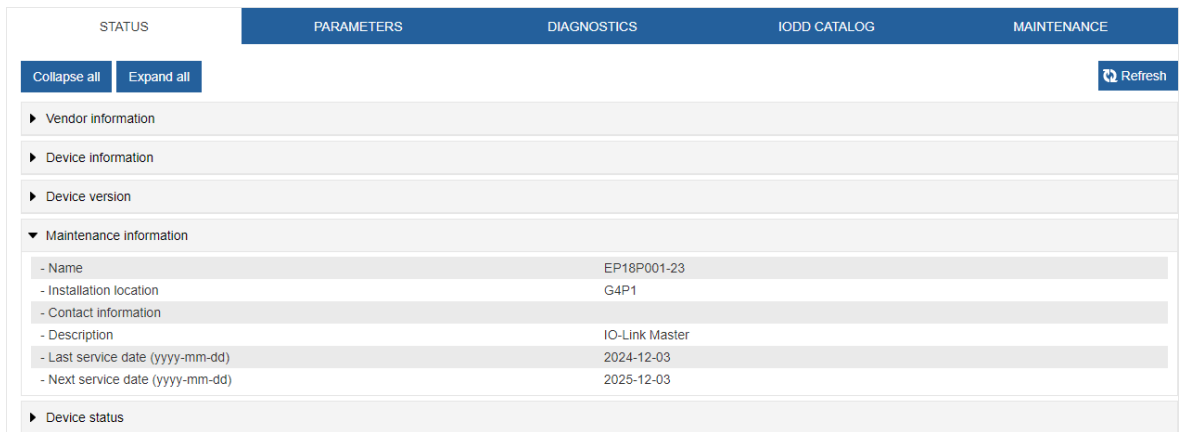

Users with service, maintenance and admin rights can enter information about the device here.

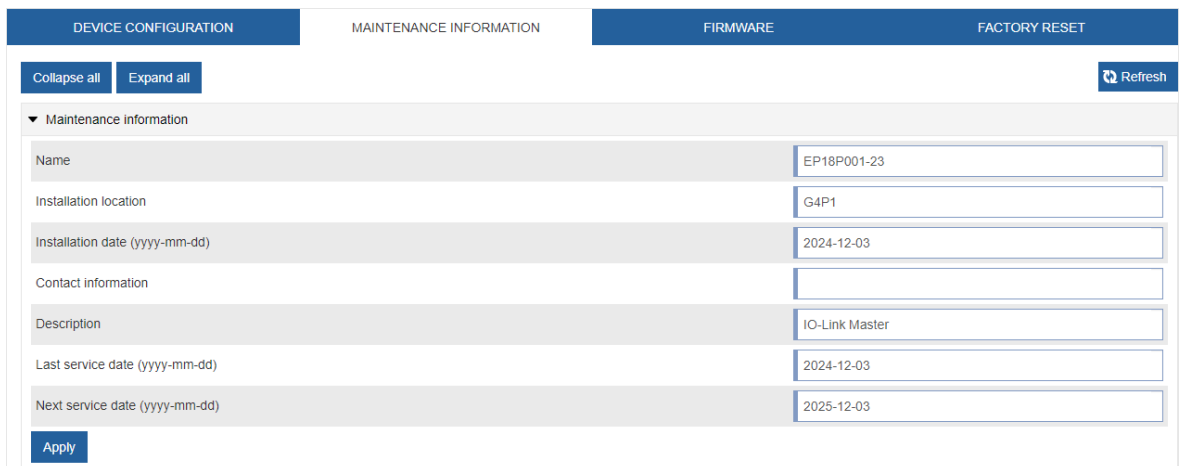

10.7.3 FIRMWARE Menu

This menu item displays the data of the firmware running on the device.

Users with service, maintenance and admin rights can install new firmware on the device here, provided in ZIP folders. After successful loading, the device checks the firmware container and starts automatically with the new firmware version.

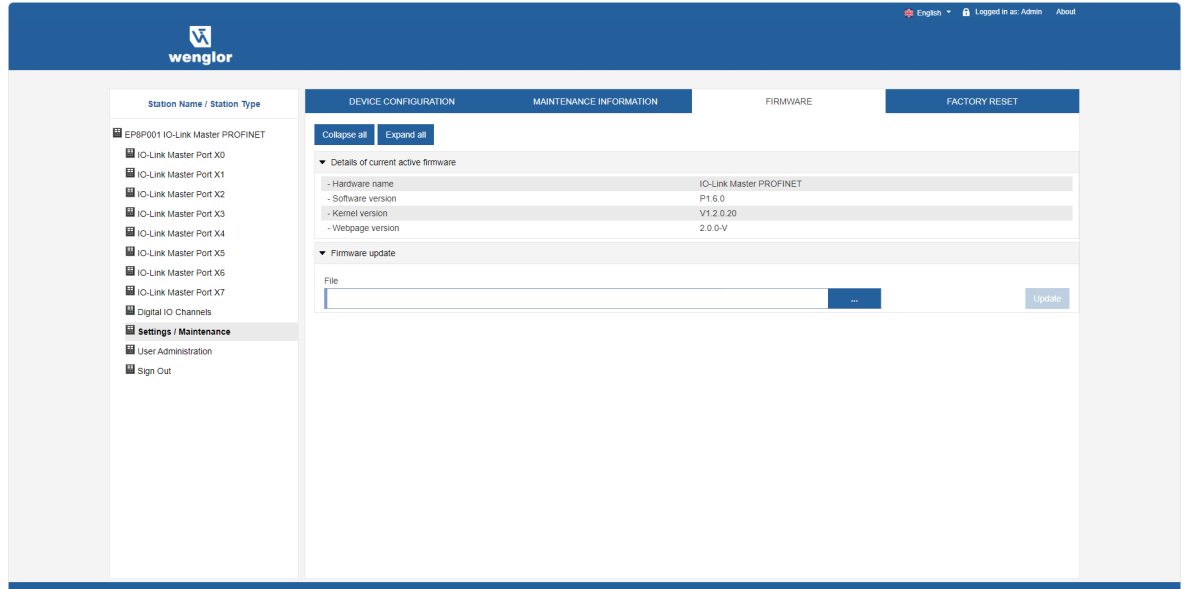

10.7.4 FACTORY RESET Menu

In this menu item, users with service, maintenance and admin rights can reset the entire device or individual sub-areas (device information, network, application).

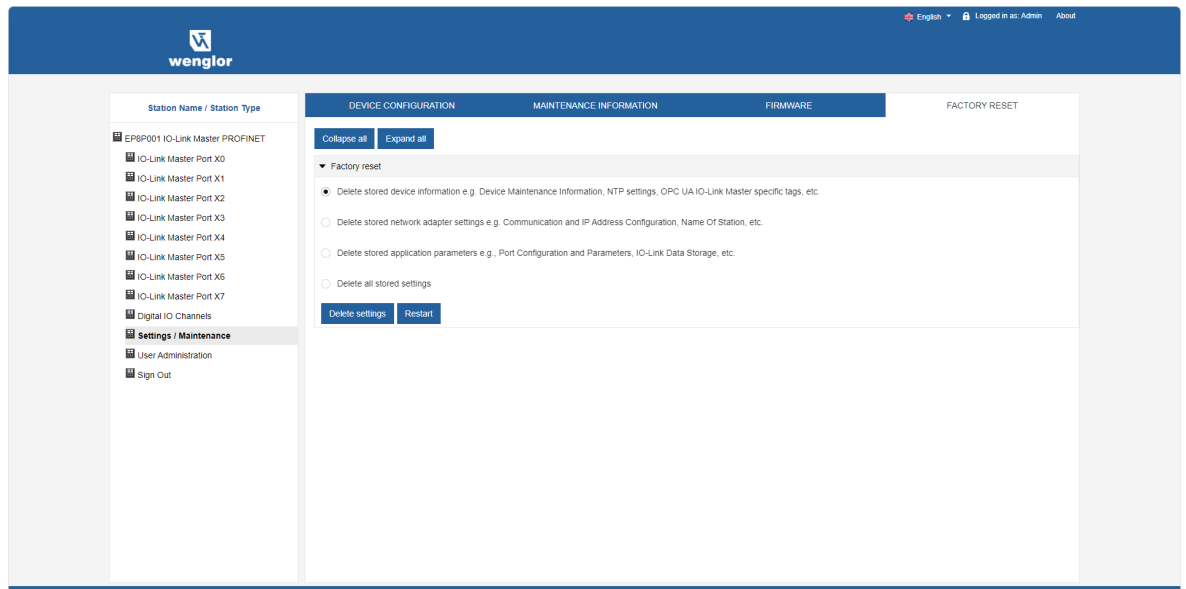

10.8 User Management

User administration can only be carried out with admin rights. Additional users with different user roles can be created here.

The administrator default password can be changed in the system with the fieldbus running from the controller.

Users log on and off in the system tree:

- Click on Logout.

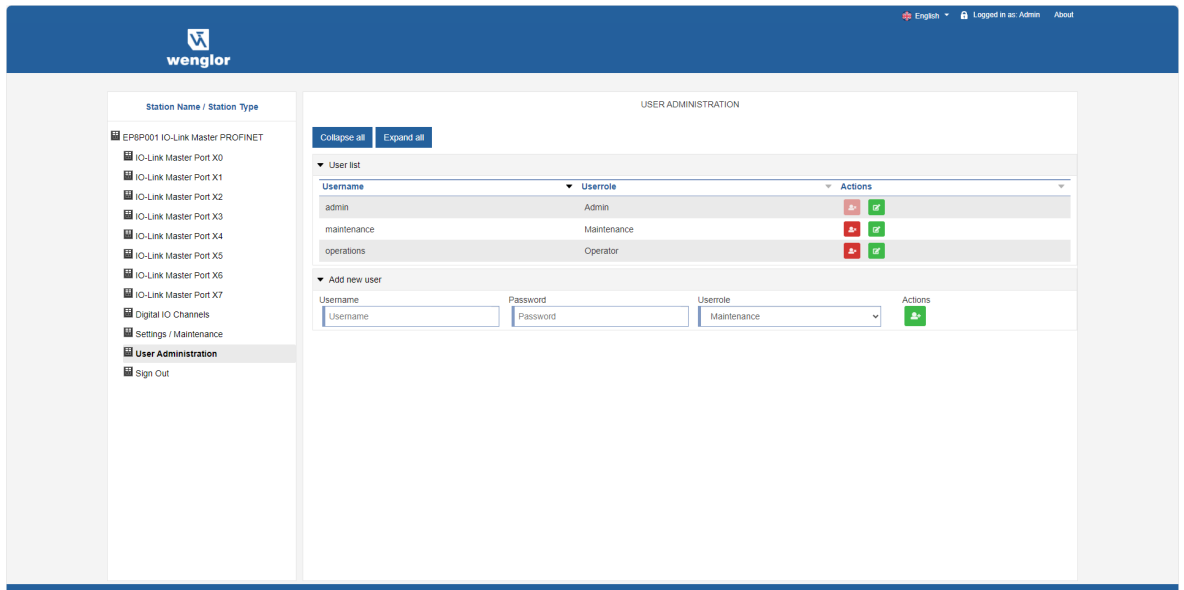

11 Appendix

11.1 Supported EtherNet/IP Objects

This section is a list of the CIP objects and services supported and implemented in this product. For more detailed descriptions of the individual objects and attributes, see the EtherNet/IP specification.

11.1.1 Standard Object Class

11.1.1.1 Identity Object (Class Code: 0x01)

Class Attribute

Attribute ID	Access rule	Name	Data type	Attribute description	Value semantics
1	Get	Revision	UINT	Object revision	The value two (02) is currently assigned to this attribute. For updates that require an increase in this value, the value of this attribute is increased by 1
2	Get	Max. Instance	UINT	Maximum instance number of an object that is currently created in this class level of the device.	The largest instance number of a created object in this class hierarchy level. The value currently assigned to this attribute is one (01).
6	Get	Max ID Class Attribute	UINT	The ID number of the last class attribute of the class definition implemented in the device.	The value of this attribute is seven (07).
7	Get	Max ID Instance Attributes	UINT	The ID number of the last instance attribute of the class definition implemented in the device.	The value of this attribute varies depending on the product variant. This attribute displays nine (09).

Instance Attribute

Attribute ID	Access rule	Name	Data type	Attribute description	Value semantics
1	Get	Vendor ID	UINT	Identify each vendor by number	640
2	Get	Device Type	UINT	Indication of the general product type	7
3	Get	Product Code	UINT	Identifying a specific product from a single vendor	
4	Get	Revision	STRUCT of:	Change the element representing the Identity Object	
		Major Revision	USINT	Major firmware revision	
		Minor Revision	USINT	Minor firmware revision	
5	Get	State	WORD	Summarized status information about the device	
6	Get	Serial Number	UDINT	Serial number of device	

Attribute ID	Access rule	Name	Data type	Attribute description	Value semantics
7	Get	Product Name	SHORT_STRING	Human readable designation	
8	Get	State	USINT	Current state of the device as shown by the state transition diagram	

Common Services

Service code	Implemented for		Service name	Service designation
	Class	Instance		
0x01	No	Yes	Get_Attribute_All	Provides a predefined list of these object attributes.
0x05	No	Yes	Reset	Calls the reset service for the device. Option 0 restarts the device. Option 1 calls up a factory reset of the device.
0x0E	Yes	Yes	Get_Attribute_Single	Returns the contents of the specified attribute.

11.1.1.2 Message Router Object (Class Code: 0x02)

This object has no accessible attributes.

11.1.1.3 Assembly Object (Class Code: 0x04)

Class Attribute

Attribute ID	Access rule	Name	Data type	Attribute description	Value semantics
1	GET	Revision	UINT	Object revision	The value one (01) is currently assigned to this attribute. If updates are carried out that require an increase of this value, the value of this attribute is increased by 1.

Instance Attribute

Attribute ID	Access rule	Name	Data type	Attribute description
3	Set,Get	Data	ARRAY of BYTE	
4	Get	Size	UINT	Number of bytes in attribute 3

Common Services

Service code	Implemented for		Service name	Service designation
	Class	Instance		
0x0E	Yes	Yes	Get_Attribute_Single	Returns the contents of the specified attribute.
0x10	No	Yes	Set_Attribute_Single	Changes an attribute value.

11.1.1.4 Connection Manager Object (Class Code: 0x06)

Ethernet Link Object Class Attribute

Attribute ID	Access rule	Name	Data type	Attribute description	Value semantics
1	Get	Revision	UINT	Object revision	The value one (01) is currently assigned to this attribute. If updates are made that require an increase in this value, the value of this attribute is increased by 1.
2	Get	Max. Instance	UINT	Maximum instance number of an object that is currently created in this class level of the device.	The largest instance number of a created object in this class hierarchy level. This attribute displays one (01).

Instance Attribute

No instance attributes are implemented for this object.

Shared Services

Common Services of Ethernet Link Object.

Service code	Implemented for		Service name	Service designation
	Class	Instance		
0x0E	Yes	No	Get_Attribute_Single	Delivers the contents of the specified attribute.

11.1.1.5 Device Level Ring (DLR) Object (Class Code: 0x47)

Class Attribute

Attribute ID	Access rule	Name	Data type	Attribute description	Value semantics
1	Get	Revision	UINT	Revision of this object	The value one (01) is currently assigned to this attribute. If updates are made that require an increase in this value, the value of this attribute is increased by 1.

Instance Attribute

Attribute ID	Access rule	Name	Data type	Attribute description
1	Get	Network Topology	USINT	Current Network Topology Mode
2	Get	Network State	USINT	Current network status
10	Get	Active Supervisor Address	STRUCT of:	IP and/or MAC address of the active ring supervisor
			UDINT	IP address of the supervisor
			ARRAY of 6	MAC address of the supervisor

Attribute ID	Access rule	Name	Data type	Attribute description
			USINTs	
12	Get	Capability Flags	USINT	Describes the DLR functions of the device

Common Services

Service code	Implemented for		Service name	Service designation
	Class	Instance		
0x01	No	Yes	Get_Attribute_All	Provides a predefined list of these object attributes.
0x0E	Yes	Yes	Set_Attribute_Single	Returns the contents of the specified attribute.

11.1.1.6 Quality of Service Object (Class Code: 0x48)

Class Attribute

Attribute ID	Access rule	Name	Data type	Attribute description	Value semantics
1	Get	Revision	UINT	Revision of this object	The value one (01) is currently assigned to this attribute. If updates are made that require an increase in this value, the value of this attribute is increased by 1.
2	Get	Max. Instance	UINT	Maximum instance number of an object that is currently created in this class level of the device.	The largest instance number of a created object in this class hierarchy level. This attribute displays one (01).

Instance Attribute

Attribute ID	Access rule	Name	Data type	Attribute description
1	Set, Get	802.1Q Tag Enable	USINT	Enables or disables sending 802.1Q frames on CIP and IEEE 1588 messages
4	Set, Get	DSCP Urgent	USINT	DSCP value for urgent priority messages for CIP transport classes 0/1
5	Set, Get	DSCP Scheduled	USINT	DSCP value for planned messages with priority for CIP transport classes 0/1
6	Set, Get	DSCP High	USINT	DSCP value for high priority messages for CIP transport classes 0/1
7	Set, Get	DSCP Low	USINT	DSCP value for low priority messages for CIP transport classes 0/1
8	Set, Get	DSCP Explicit	USINT	DSCP value for explicit CIP messages (transport class 2/3 and UCMM) and all other encapsulated EtherNet/IP messages

Common Services

Service code	Implemented for		Service name	Service designation
	Class	Instance		
0x0E	Yes	Yes	Get_Attribute_All	Returns the contents of the specified attribute.
0x10	No	Yes	Set_Attribute_Single	Changes the contents of the attributes of the class or object.

11.1.1.7 TCP/IP Interface Object (Class Code: 0xF5)

Class Attribute

Attribute ID	Access rule	Name	Data type	Attribute description	Value semantics
1	Get	Revision	UINT	Revision of this object	The value four (04) is currently assigned to this attribute. If updates are made that require an increase in this value, the value of this attribute is increased by 1.
2	Get	Max. Instance	UINT	Maximum instance number of an object that is currently created in this class level of the device.	The largest instance number of a created object in this class hierarchy level. This attribute displays one (01).

Instance Attribute

Attribute ID	Access rule	Name	Data type	Attribute description
1	Set, Get	802.1Q Tag Enable	USINT	Enables or disables sending 802.1Q frames on CIP and IEEE 1588 messages
2	Get	Configuration Capability	USINT	Interface capability flag
3	Set, Get	Configuration Capability	USINT	Interface control flag
4	Get	Physical Link Object	STRUCT of	Path to physical link object
		Path size	UINT	Path size
		Path	Padded EPATH	Logical segments that identify the physical link object
5	Set, Get	Interface Configuration	STRUCT of	TCP/IPNetwork Interface configuration.
		IP Address	UDINT	Device IP address
		Network Mask	UDINT	Device network mask
		Gateway Address	UDINT	Default gateway address
		Name server	UDINT	Primary name server
		Name server 2	UDINT	Secondary name server
Domain Name	STRING	Default domain name		

Attribute ID	Access rule	Name	Data type	Attribute description
6	Set, Get	Host Name	STRING	Host name
10	Set, Get	SelectAcid	BOOL	Enables ACD usage
11	Set, Get	LastConflictDetecte	STRUCT of	Structure that contains information on the last detected conflict
		AcidActivity	USINT	Status of the ACD activity when the last conflict was detected
		RemoteMAC	Array of 6 USINT	MAC address of a remote node of the ARP PDU in which the conflict was detected
		ArpPdu	ARRAY of 28 USINT	Copy of the raw ARP PDU in which the conflict was detected
12	Unused			
13	Get	Encapsulation Inactivity Timeout	UINT	Number of seconds of inactivity before closing the TCP connection or DTLS session

Common Services

Service code	Implemented for		Service name	Service designation
	Class	Instance		
0x01	No	Yes	Get_Attribute_All	Provides a predefined list of these object attributes.
0x0E	Yes	Yes	Get_Attribute_All	Returns the contents of the specified attribute.
0x10	No	Yes	Set_Attribute_Single	Changes a single attribute..

11.1.1.8 EtherNet/IP Link Object (Class Code: 0xF6)

Class Attribute

Attribute ID	Access rule	Name	Data type	Attribute description	Value semantics
1	Get	Revision	UINT	Revision of this object	The value four (04) is currently assigned to this attribute. If updates are made that require an increase in this value, the value of this attribute is increased by 1.
2	Get	Max. Instance	UINT	Maximum instance number of an object that is currently created in this class level of the device.	The largest instance number of a created object in this class hierarchy level. This attribute displays two (02).
3	Get	Number of Instances	UINT	Number of object instances currently created in this class level of the device.	The number of object instances in this class hierarchy level. This attribute displays two (02).

Instance Attribute

Attribute ID	Access rule	Name	Data type	Attribute description
1	Get	Interface Speed	USINT	Interface speed

Attribute ID	Access rule	Name	Data type	Attribute description
2	Get	Interface Flags	USINT	Interface status flag
3	Get	Physical Address	USINT	MAC Layer Address
4		Interface Counters	STRUCT of	
		In Octets	UDINT	Octet received at the interface
		In Ucast Packets	UDINT	Unicast packets received on the interface
		In NUcast packets	UDINT	Non-unicast packets received on the interface
		In Discards	UDINT	Incoming packets received but rejected at the interface
		In Errors	UDINT	Incoming packets containing errors (excluded in Discards)
		In Unknown Protos	UDINT	Incoming packets with unknown protocol
		Out Octets	UDINT	Octet sent to the interface
		Out Ucast Packets	UDINT	Unicast packets sent to the interface
		Out NUcast Packets	UDINT	Non-unicast packets sent to the interface
		Out Discards	UDINT	Outbound packets discarded
		Out Errors	UDINT	Outgoing packets containing errors
5	Get	Media Counters	STRUCT of	Media-specific counters
		Alignment Errors	UDINT	Receive frames that are not just full octets
		FCS Errors	UDINT	Received frames that fail the FCS check
		Single Collisions	UDINT	Successfully transferred frames that have exactly experienced a collision
		Multiple collisions	UDINT	Successfully transferred frames that have experienced more than one collision
		SQE Test Errors	UDINT	Number of error messages generated by SQE test
		Deferred Transmissions	UDINT	Frames whose transmission is delayed by a busy medium
		Late Collisions	UDINT	Number of times a collision is detected later than after 512 bits of the packet are transmitted
		Excessive Collisions	UDINT	Frames whose transmission fails due to intense collisions
		MAC Transmit Errors	UDINT	Frames whose transmission failed due to an internal transmission error in the MAC sublayer
		Carrier Sense Errors	UDINT	Number of failed or not performed carrier checks when trying to transfer a frame
		Frame Too Long	UDINT	Frames exceeding the maximum permitted size
		MAC Receive Errors	UDINT	Frames whose reception at the interface fails due to an internal reception error in the MAC sublayer

Attribute ID	Access rule	Name	Data type	Attribute description
6	Set, Get	Interface Control	STRUCT of	Physical interface configuration
		Control Bits	WORD	Interface control bits
		Forced Interface Speed	UINT	Speed at which the interface should work
7	Get	Interface Type	USINT	Twisted pair, fiber, internal, etc.
8	Get	Interface State	USINT	Current status of the interface: in operation, deactivated, etc.
9	Set, Get10	Admin State	USINT	Administrative status: activated, deactivated
10	Set, Get	Interface Label	SHORT_STRING	Human readable designation
11	Get	Interface Capability	STRUCT of	Display of interface capabilities
		Capability Bits	DWORD	Interface capabilities excluding speed and duplex
		Speed/Duplex Options	STRUCT of	Displays the speed and duplex pairs supported by the interface control attribute
			USINT	Speed/duplex array counter
		ARRAY of STRUCT of	Speed/duplex array	
		UINT	Interface speed	
		UINT	Interface duplex mode	

Common Services

Service code	Implemented for		Service name	Service designation
	Class	Instance		
0x01	No	Yes	Get_Attribute_All	Provides a predefined list of these object attributes.
0x0E	Yes	Yes	Get_Attribute_Single	Returns the contents of the specified attribute.
0x4C	No	Yes ¹	Set_Attribute_Single	Changes a single attribute..

¹ The Get_and_Clear service is only implemented for the attributes 4 and 5.

11.1.2 Vendor-Specific Objects

11.1.2.1 IO-Link Device Parameter Object (Class Code 0x83)

Class Attribute

Attribute ID	Access rule	Name	Data type	Attribute description	Value semantics
1	Get	Revision	UINT	Revision of this object	The value one (01) is currently assigned to this attribute. If updates are made that require an in-

Attribute ID	Access rule	Name	Data type	Attribute description	Value semantics
					crease in this value, the value of this attribute is increased by 1.
2	Get	Max. Instance	UINT	Maximum instance number of an object that is currently created in this class level of the device.	The largest instance number of a generated object in this class hierarchy level This attribute displays one (01).
6	Get	Max ID Class Attribute	UINT	The ID number of the last class attribute of the class definition implemented in the device.	The value of this attribute is seven (07).
7	Get	Max ID Instance Attributes	UINT	The ID number of the last instance attribute of the class definition implemented in the device.	The value of this attribute varies depending on the product variant. Part number 55143 has 2 and part number 55144 has 4.

Instance Attribute

Instance attributes are not supported.

Object-Specific Services

The following class-specific services are defined for the IO-Link Device parameter object.

Service code	Implemented for		Service name	Service designation
	Class	Instance		
0x4B	No	Yes	Read_ISDU	Read parameters in the IO-Link device in raw format, i.e. Big Endian
0x4C	No	Yes	Write_ISDU	Write parameters to the IO-Link device in raw format, i.e. Big Endian

Read_ISDU Service

Name	Data type	Description
Index	UINT	IO-Link device index
Subindex	USINT	IO-Link device subindex

Write_ISDU Service

Name	Data type	Description
Index	UINT	IO-Link device index
Subindex	USINT	IO-Link device subindex
Data	ARRAY of USINT	IO-Link device ISDU data

11.2 Explanation of the Process Data

11.2.1 Digital Input

The sequence of the digital input data depends on the configuration parameter “Pin_Port_based_IO_Layout”. The following tables explain this:

Port Based

Byte	1								0							
Bits	7	6	5	4	3	2	1	0	7	6	5	4	3	2	1	0
Port	X7	X7	X6	X6	X5	X5	X4	X4	X3	X3	X2	X2	X1	X1	X0	X0
Pin	2	4	2	4	2	4	2	4	2	4	2	4	2	4	2	4
Channel	17	07	16	06	15	05	14	04	13	03	12	02	11	01	10	00

Pin Based

Byte	1								0							
Bits	7	6	5	4	3	2	1	0	7	6	5	4	3	2	1	0
Port	X7	X7	X6	X6	X5	X5	X4	X4	X3	X3	X2	X2	X1	X1	X0	X0
Pin	2	2	2	2	2	2	2	2	4	4	4	4	4	4	4	4
Channel	17	16	15	14	13	12	11	10	07	06	05	04	03	02	01	00



INFORMATION

The tables for Port and Pin Based are also valid for Digital Input Qualifier, Digital Output Qualifier and Digital Output.

11.2.2 DI Qualifier

The digital input qualifiers provide you with information about the integrity of the input signal quickly.

Bit value	Description
0	Invalid
1	Valid



INFORMATION

Bit sequence depends on configuration parameter “Pin_Port_based_IO_Layout”. See section 12.2.1 “Digital Input”

11.2.3 DO Qualifier

The digital output qualifiers provide you with information about the integrity of the output signal in a quickly.

Bit value	Description
0	Invalid
1	Valid



INFORMATION

Bit sequence depends on configuration parameter "Pin_Port_based_IO_Layout". See Section 12.2 "Explanation of process data"

11.2.4 System Status

The system status bit bar reflects the information about the entire device.

Byte	Description
0...3	Bit 0: Undervoltage at bus and sensor supply power Bit 1: Undervoltage at actuator supply power Bit 2: No actuator supply power Bit 3: Reserved Bit 4: At least one channel has a sensor short circuit Bit 5: At least one channel has an actuator short circuit Bit 6: Reserved Bit 7: Reserved Bit 8: Reserved Bit 9: At least one IO-Link channel has an error (except wire break) Bit 10: Overvoltage at bus/sensor supply power Bit 11: Overvoltage at actuator supply power Bit 12: At least one IO-Link channel has a wire break Bit 13 ... 31: Reserved, set to 0

11.2.5 IO-Link Port X Status

Byte	Description	Value
0...1	IO-Link Data Status	Bit 0 - 4: reserved Bit 5: DevCom, is set when a device is detected and is in the PREOPERATE or OPERATE state. It is reset if no device is present. Bit 6: DevErr, set when an error or warning has occurred that is assigned to either a device or a port. It is reset when there is no fault or warning. Bit 7: PQ, is set when valid process data is exchanged between master and device. It is reset if the process data is not valid.
2...3	Vendor ID of connected IO-Link Device	
4...7	Device ID of connected IO-Link Device	

11.2.6 Diagnostic Buffer

The diagnostic buffer consists of an array of diagnostics structures and has a length of 8 structures. A diagnostics structure is 8 bytes in size. This gives the total length of the diagnostic buffer 64 bytes.



INFORMATION

For further information on a diagnostics structure, please see Diagnostic Structure in the Control System [▶ 73]

11.2.7 Digital Output



INFORMATION

The sequence of the digital output data depends on the configuration parameter “Pin_Port_based_IO_Layout”. See Digital Input [▶ 106]

12 Maintenance Instructions



NOTICE

This wenglor product is maintenance-free.

Cleaning and inspection of the plug connections at regular intervals are advisable.

Do not clean the product with solvents or cleaning agents that could damage the product.

The product must be protected against contamination during initial start-up.

13 Proper Disposal

wenglor sensoric GmbH does not accept the return of unusable or irreparable products. Respectively valid national waste disposal regulations apply to product disposal.

14 **Declarations of Conformity**

Declarations of conformity can be found on our website at www.wenglor.com in the product's separate download area.