

Through-Beam Sensor

ZK100VD8

LASER

Part Number



- Miniature design
- Rugged design with full encapsulation

Technical Data

Optical Data	
Range	10000 mm
Smallest Recognizable Part	500 μm
Switching Hysteresis	< 15 %
Light Source	Laser (red)
Service Life (T = +25 °C)	100000 h
Laser Class (EN 60825-1)	2
Max. Ambient Light	10000 Lux
Opening Angle	5 °

Electrical Data	
Sensor Type	Receiver
Supply Voltage	10...30 V DC
Current Consumption (U _b = 24 V)	< 20 mA
Switching Frequency	5 kHz
Response Time	100 μs
Temperature Drift	< 10 %
Temperature Range	-25...60 °C
Switching Output Voltage Drop	< 2,5 V
Switching Output/Switching Current	100 mA
Short Circuit and Overload Protection	yes
Reverse Polarity Protection	yes
Protection Class	III

Mechanical Data	
Setting Method	Potentiometer
Housing Material	Plastic
Full Encapsulation	yes
Degree of Protection	IP67
Connection	M8 \times 1; 3-pin
PNP NC	●
Connection Diagram No.	109
Control Panel No.	K1
Suitable Connection Technology No.	8
Suitable Mounting Technology No.	400

Suitable Emitter

ZK1008

These through beam sensors are best suited for use in industrial environments. Thanks to their large working range, the devices demonstrate excellent functional reliability in highly contaminated environments. The sensors can be checked for correct functioning via the test input.

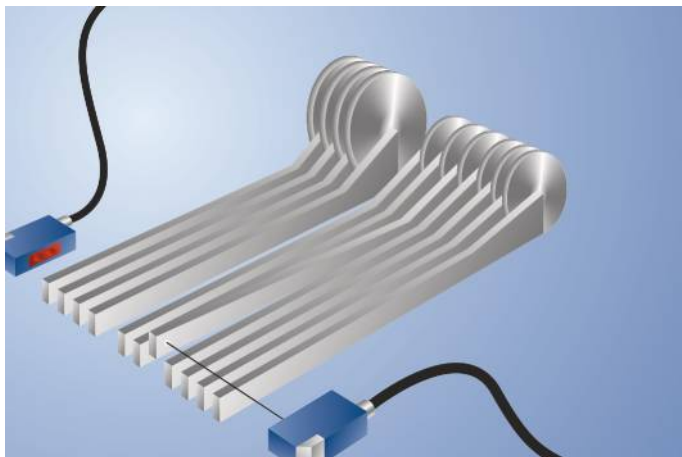

Complementary Products

PNP-NPN Converter BG8V1P-N-2M

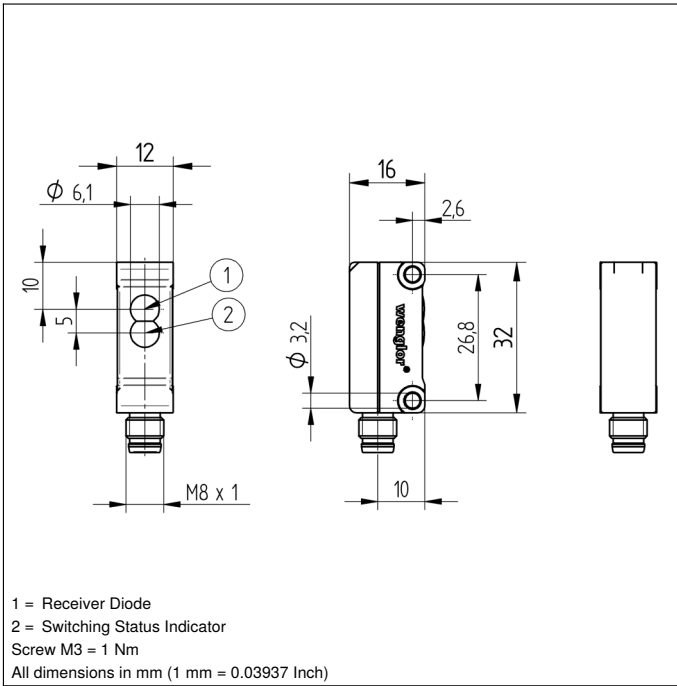

Ctrl. Panel

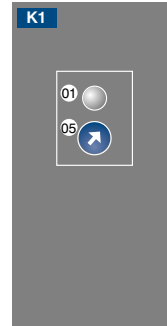

01 = Switching Status Indicator
 05 = Switching Distance Adjuster

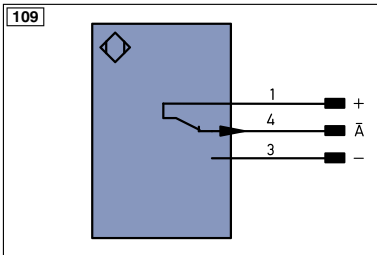

Legend

+	Supply Voltage +	nc	not connected	ENa	Encoder A
-	Supply Voltage 0 V	U	Test Input	ENb	Encoder B
~	Supply Voltage (AC Voltage)	U	Test Input inverted	AMIN	Digital output MIN
A	Switching Output (NO)	W	Trigger Input	AMAX	Digital output MAX
A̅	Switching Output (NC)	O	Analog Output	AOK	Digital output OK
V	Contamination/Error Output (NO)	O-	Ground for the Analog Output	SY In	Synchronization In
V̅	Contamination/Error Output (NC)	BZ	Block Discharge	SY OUT	Synchronization OUT
E	Input (analog or digital)	AWV	Valve Output	Out	Brightness output
T	Teach Input	a	Valve Control Output +	M	Maintenance
Z	Time Delay (activation)	b	Valve Control Output 0 V		
S	Shielding	SY	Synchronization		
RxD	Interface Receive Path	E+	Receiver-Line		
TxD	Interface Send Path	S+	Emitter-Line		
RDY	Ready	≡	Grounding		
GND	Ground	SnR	Switching Distance Reduction		
CL	Clock	Rx+/-	Ethernet Receive Path		
E/A	Output/Input programmable	Tx+/-	Ethernet Send Path		
	IO-Link	Bus	Interfaces-Bus A(+)/B(-)		
PoE	Power over Ethernet	La	Emitted Light disengageable		
IN	Safety Input	Mag	Magnet activation		
OSSD	Safety Output	RES	Input confirmation		
Signal	Signal Output	EDM	Contactor Monitoring		
Bl..D+/-	Ethernet Gigabit bidirect. data line (A-D)	ENAR5422	Encoder A/A̅ (TTL)		
EN0.R5422	Encoder 0-pulse 0-0̅ (TTL)	ENBR5422	Encoder B/B̅ (TTL)		

Wire Colors according to DIN IEC 757

BK	Black
BN	Brown
RD	Red
OG	Orange
YE	Yellow
GN	Green
BU	Blue
VT	Violet
GY	Grey
WH	White
PK	Pink
GNVE	Green/Yellow

Smallest Recognizable Part

Based on the Distance between Emitter and Receiver

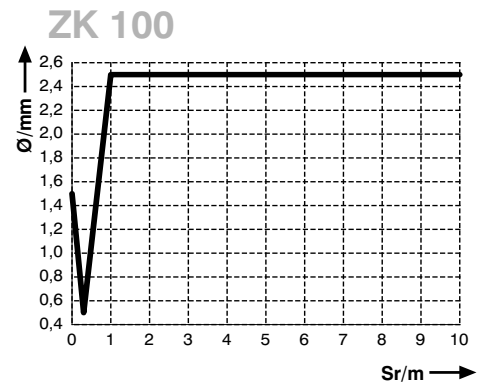

Sr = Switching Distance

Ø = Diameter, Smallest Recognizable Part

