

# Operating Instructions

## **P1PY207**

### **Laser Distance Sensor ToF**



EN



# Table of Contents

<b>1</b>	<b>General</b>	<b>4</b>
1.1	Information Concerning these Instructions	4
1.2	Explanation of Symbols	4
1.3	Limitation of Liability	5
1.4	Copyrights	5
<b>2</b>	<b>For Your Safety</b>	<b>6</b>
2.1	Use for Intended Purpose	6
2.2	Use for Other than the Intended Purpose	6
2.3	Personnel Qualifications	6
2.4	Modification of Products	7
2.5	General Safety Precautions	7
2.6	Laser Warnings	7
2.7	Approvals and Protection Class	7
<b>3</b>	<b>Technical Data</b>	<b>9</b>
3.1	General Data	9
3.1.1	Light Spot Diameter	10
3.2	Warm-Up Phase	10
3.3	Working Range	10
3.3.1	Switching Distance Deviation	10
3.4	Mode-Dependent Data	11
3.5	Housing Dimensions	12
3.6	Control Panel	12
3.7	Complementary Products	12
3.8	Scope of delivery	13
<b>4</b>	<b>Transport and Storage</b>	<b>14</b>
4.1	Transport	14
4.2	Storage	14
<b>5</b>	<b>Installation and Electrical Connection</b>	<b>15</b>
5.1	Installation	15
5.2	Electrical Connection	15
5.3	Diagnosis	16
5.4	Troubleshooting	17
<b>6</b>	<b>Settings</b>	<b>19</b>
6.1	Configuration with Push of Button / Teach-In	19
<b>7</b>	<b>Settings via menu</b>	<b>20</b>
<b>8</b>	<b>Function Description</b>	<b>23</b>
8.1	Sensor Functions	23
8.2	Display Functions	25
8.3	Input/Output Functions (E/A)	26
8.3.1	Pin Function	26
8.3.2	Output Functions	26
8.3.3	Input Functions	27
8.4	Switching Point Functions (SSC1/SSC2)	27
8.5	Condition Monitoring Functions	30

8.5.1	Status Message Function .....	30
8.5.2	Warning/Error Output Function .....	31
8.5.3	Speed Measurement .....	32
8.5.4	Signal Monitoring .....	32
8.5.5	Simulation Functions .....	32
<b>9</b>	<b>Bluetooth .....</b>	<b>34</b>
9.1	weCon Installation .....	34
9.2	Establishing Connection with Sensor .....	34
9.3	Using the weCon App.....	35
<b>10</b>	<b>IO-Link .....</b>	<b>36</b>
10.1	Parameters.....	36
10.2	Condition Monitoring/Process Data.....	36
10.2.1	Process Data In.....	36
10.2.2	Process Data Out.....	36
10.2.3	Events.....	36
<b>11</b>	<b>wTech2 Configuration Software.....</b>	<b>38</b>
<b>12</b>	<b>Maintenance Instructions .....</b>	<b>39</b>
<b>13</b>	<b>Proper Disposal .....</b>	<b>40</b>
<b>14</b>	<b>Declarations of Conformity.....</b>	<b>41</b>

# 1 General

## 1.1 Information Concerning these Instructions

- These instructions make it possible to use the product safely and efficiently.
- These instructions are an integral part of the product and must be kept on hand for the entire duration of its service life.
- Local accident prevention regulations and national work safety regulations must be complied with as well.
- The product is subject to further technical development, and thus the information contained in these operating instructions may also be subject to change. The current version can be found at [www.wenglor.com](http://www.wenglor.com) in the product's separate download area.



### INFORMATION

The operating instructions must be read carefully before using the product and must be kept on hand for later reference.

## 1.2 Explanation of Symbols

- Safety precautions and warnings are emphasized by means of symbols and signal words.
- Safe use of the product is only possible if these safety precautions and warnings are adhered to.

The safety precautions and warnings are laid out in accordance with the following principle:

### SIGNAL WORD

#### Type and source of danger!

Possible consequences in the event that the hazard is disregarded.

→ Measures for averting the hazard.

The meanings of the signal words, as well as the scope of the associated hazards, are listed below:



### DANGER

This signal word indicates a hazard with a high degree of risk which, if not avoided, results in death or severe injury.



### WARNING

This signal word indicates a hazard with a medium degree of risk which, if not avoided, may result in death or severe injury.



### CAUTION

This signal word indicates a hazard with a low degree of risk which, if not avoided, may result in minor or moderate injury.



### NOTICE

This signal word draws attention to a potentially hazardous situation which, if not avoided, may result in property damage.



## INFORMATION

Information draws attention to useful tips and suggestions, as well as information on efficient, error-free use.

---

### 1.3 Limitation of Liability

- The product has been developed in consideration of the current state-of-the-art technology, as well as applicable standards and guidelines. Subject to change without notice.
- A valid declaration of conformity can be accessed at [www.wenglor.com](http://www.wenglor.com) in the product's separate download area.
- wenglor sensoric elektronische Geräte GmbH (hereinafter referred to as "wenglor") excludes all liability in the event of:
  - Non-compliance with the instructions
  - Use of the product for purposes other than those intended.
  - Use by untrained personnel.
  - Use of unapproved spare parts.
  - Unapproved modification of products.
- These operating instructions do not include any guarantees from wenglor with regard to the described procedures or specific product characteristics.
- wenglor assumes no liability for printing errors or other inaccuracies contained in these operating instructions unless wenglor was verifiably aware of such errors at the point in time at which the operating instructions were prepared.

### 1.4 Copyrights

- The contents of these instructions are protected by copyright law.
- All rights are reserved by wenglor.
- Commercial reproduction or any other commercial use of the provided content and information, in particular graphics and images, is not permitted without previous written consent from wenglor.

## 2 For Your Safety

### 2.1 Use for Intended Purpose

#### Laser Distance Sensors ToF

Laser distance sensors Time-of-Flight (ToF) work according to the principle of transit time measurement, which means that they cover large working ranges up to 10,000 mm, so that objects can be reliably detected even at great distances. The ToF sensors are extremely robust against interfering ambient light, which ensures reliable operation.

#### This Product Can Be Used in the Following Industry Sectors:

- Special-purpose mechanical engineering
- Heavy mechanical engineering
- Logistics
- Automotive industry
- Food industry
- Packaging industry
- Pharmaceuticals industry
- Plastics industry
- Woodworking industry
- Consumer goods industry
- Paper industry
- Electronics industry
- Glass industry
- Steel industry
- Aviation industry
- Chemicals industry
- Alternative energies
- Raw materials extraction

### 2.2 Use for Other than the Intended Purpose

- Not a safety component in accordance with 2006/42/EC (Machinery Directive).
- The product is not suitable for use in potentially explosive atmospheres.
- The product may be used only with accessories supplied or approved by wenglor, or in combination with approved products. A list of approved accessories and combination products can be found at [www.wenglor.com](http://www.wenglor.com) on the product detail page.



#### **DANGER**

#### **Risk of personal injury or property damage in case of use for other than the intended purpose!**

Use for other than the intended purpose may lead to hazardous situations.

→ Observe instructions regarding use for intended purpose.

### 2.3 Personnel Qualifications

- Suitable technical training is a prerequisite.
- In-house electronics training is required.
- Trained personnel who use the product must have (permanent) access to the operating instructions.



## **DANGER**

### **Risk of personal injury or property damage in case of incorrect initial start-up and maintenance!**

Personal injury and damage to equipment may occur.

→ Adequate training and qualification of personnel

## 2.4 Modification of Products



## **DANGER**

### **Risk of personal injury or property damage if the product is modified!**

Personal injury and damage to equipment may occur. Noncompliance may result in loss of the CE and/or UKCA mark and voiding of the warranty.

→ Modification of the product is not permitted

## 2.5 General Safety Precautions



## **INFORMATION**

These instructions are an integral part of the product and must be kept on hand for the entire duration of its service life.

In the event of possible changes, the current version of the operating instructions can be found at [www.wenglor.com](http://www.wenglor.com) in the product's separate download area.

Read the operating instructions carefully before using the product.

Protect the sensor against contamination and mechanical influences.

## 2.6 Laser Warnings



### **Laser Class 1 (EN 60825-1)**

Applicable standards and safety regulations must be observed.

## 2.7 Approvals and Protection Class

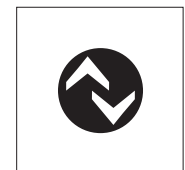
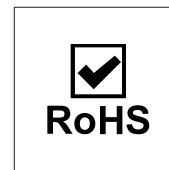
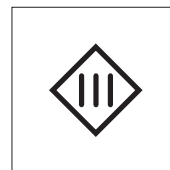
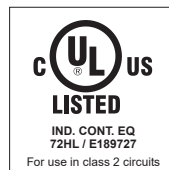



## NOTICE

This equipment has been tested and found to comply with the limits for a Class A digital device, pursuant to part 15 of the FCC Rules. These limits are designed to provide reasonable protection against harmful interference when the equipment is operated in a commercial environment. This equipment generates, uses, and can radiate radio frequency energy and, if not installed and used in accordance with the instruction manual, may cause harmful interference to radio communications. Operation of this equipment in a residential area is likely to cause harmful interference in which case the user will be required to correct the interference at his own expense.

This device complies with part 15 of the FCC Rules.

Operation is subject to the following two conditions:

- (1) This device may not cause harmful interference, and
- (2) this device must accept any interference received, including interference that may cause undesired operation.

FCC Caution: Any changes or modifications not expressly approved by the party responsible for compliance could void the user's authority to operate this equipment.

---

## 3 Technical Data

### 3.1 General Data

Technical Data	
<b>Optical Data</b>	
Working Range	0 ... 10000 mm
Measuring Range	50 ... 10000 mm
Reproducibility maximum	3 mm*
Linearity Deviation	10 mm*
Light Source	Laser (red)
Wavelength	660 nm
Service Life (T = +25 °C)	100000 h
Laser Class (EN 60825-1)	1
Beam Divergence	< 2 mrad
Max. Ambient Light	100000 Lux
Light Spot Diameter	See section Light Spot Diameter [► 10]
<b>Electrical Data</b>	
Supply Voltage	18 ... 30 V DC
Current Consumption (U <sub>b</sub> = 24 V)	< 60 mA
Measuring Rate	100 /s*
Measuring Rate (max.)	500 /s*
Temperature Drift	< 0.4 mm/K
Temperature Range	-40 ... 50 °C
Analog Output	0...10 V
Short Circuit Protection	yes
Reverse Polarity Protection	yes
Overload Protection	yes
Interface	IO-Link V1.1.3
IO-Link transmission speed	COM3
Protection Class	III
<b>Mechanical Data</b>	
Setting Method	(OLED)/Bluetooth menu
Housing Material	Plastic, ABS
Optic Cover	Plastic, PMMA
Degree of Protection	IP67/IP68
Connection	M12 × 1; 5-pin
Contains FCC ID: 2A30LDC1392	x
<b>Output functions</b>	
	Analog Output PNP
Circuit	NO contact
<b>Safety technology data</b>	
MTTFd (EN ISO 13849-1)	349.11 a

\* Depends on mode, see section Mode-dependent data [► 11]

### 3.1.1 Light Spot Diameter

Working Distance	0 m	5 m	10 m
Light Spot Diameter	5 mm	10 mm	15 mm

## 3.2 Warm-Up Phase

The warm-up phase lasts 6 minutes. The switch-on drift during this time is shown in the following diagram.

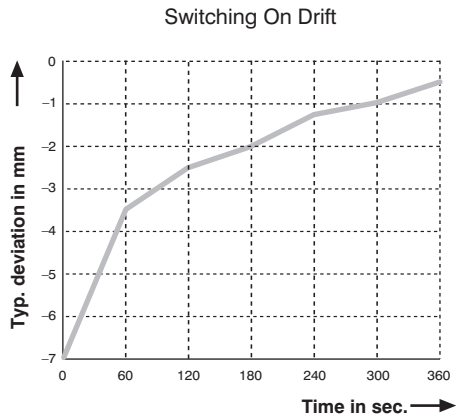

### NOTICE

Specifications correspond to measured value without load. With the analog variants, specifications may differ due to the load on the analog output.

## 3.3 Working Range

The sensor's working range is influenced by two parameters:

- Object remission
- Ambient light

The following values become typical in Precision mode (default):

Remission	Ambient light			
	100 lux	5,000 lux	20,000 lux	100,000 lux
White (90% remission)	50...10,000 mm	50...10,000 mm	50...10,000 mm	50...10,000 mm
Gray (18% remission)	50...10,000 mm	50...10,000 mm	50...10,000 mm	50...5,000 mm
Black (6% remission)	50...8,000 mm	50...6,500 mm	50...5,500 mm	50...3,000 mm

### 3.3.1 Switching Distance Deviation

Typical characteristic curve based on Kodak white (90% remission).

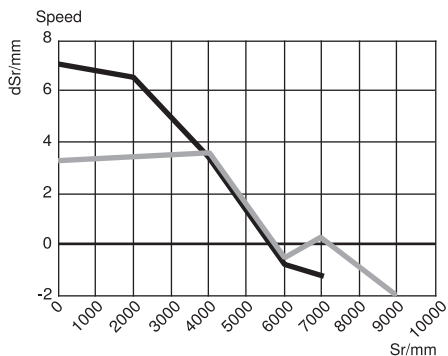

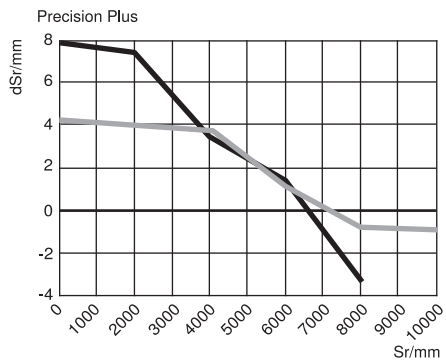
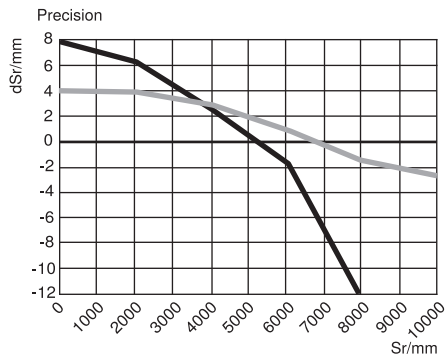

Sr = switching distance

dSr = change in switching distance

Black, 6% remission

Gray, 18% remission

### 3.4 Mode-Dependent Data

Some technical data depend on the mode set. Depending on the setting, the following data are obtained:

Mode	Working range White (90% remission)	Working range Gray (18% remission)	Working range Black (6% remission)	Measuring rate	Maximum reproducibility	Linearity deviation	Low signal detection
Speed	0... 10,000 mm	0... 9,000 mm	0... 7,000 mm	500/s	5 mm	15 mm	+
Precision (default)	0... 10,000 mm	0... 10,000 mm	0... 8,000 mm	100/s	3 mm	10 mm	++
Precision Plus	0... 10,000 mm	0... 10,000 mm	0... 8,000 mm	50/s	3 mm	10 mm	+++

## 3.5 Housing Dimensions

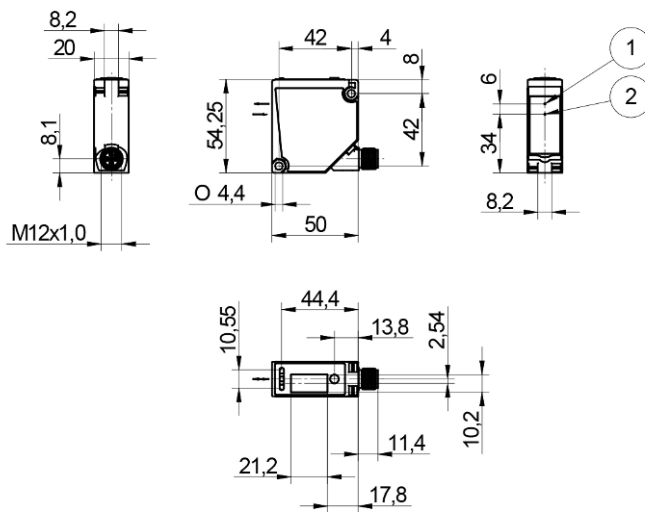

① = emitter diode

② = receiver diode

M4 screw = 0.5 Nm

Dimensions in mm (1 mm = 0.03937 inch)

## 3.6 Control Panel

**X6**

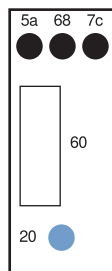

5a = switching status display, A1

7c = analog output O display

20 = enter key

60 = display

68 = power LED

## 3.7 Complementary Products

wenglor offers you the right connection and mounting technology as well as other accessories for your product. You can find this at [www.wenglor.com](http://www.wenglor.com) on the product details page at the bottom.

## **3.8 Scope of delivery**

- Sensor
- Safety precaution
- Z1PE002 spacer sleeves

## 4 Transport and Storage

### 4.1 Transport

Upon receipt of shipment, the goods must be inspected for damage in transit. In the case of damage, conditionally accept the package and notify the manufacturer of the damage. Then return the device, making reference to damage in transit.

### 4.2 Storage

The following points must be taken into consideration with regard to storage:

- Do not store the product outdoors.
- Store the product in a dry, dust-free place.
- Protect the product against mechanical impacts.
- Protect the product against exposure to direct sunlight.



#### NOTICE

#### **Risk of property damage in case of improper storage!**

The product may be damaged.

→ Storage instructions must be complied with.

---

# 5 Installation and Electrical Connection

## 5.1 Installation

- Protect the product from contamination during installation.
- Relevant electrical and mechanical regulations, standards, and safety rules must be observed.
- Protect the product from mechanical impact.
- Ensure that the sensor is mechanically secure.
- Torque values must be observed (see section Technical Data [► 9]).
- Insert the supplied spacer sleeves into the pockets provided on the side facing the mounting surface.
- Mount the sensor using M4 screws through the mounting hole.
- Do not exceed the maximum tightening torque of 0.5 Nm.



### NOTICE

#### Risk of property damage in case of improper installation!

The product may be damaged!

→ Comply with installation instructions.



### CAUTION

#### Risk of personal injury or property damage during installation!

Personal injury and damage to the product may occur.

→ Ensure a safe installation environment.

## 5.2 Electrical Connection

- Wire the sensor in accordance with the connection diagram.
- Switch on the supply voltage (see section Technical Data [► 9]).
- If using IO-Link, connect the sensor to 18...30 V DC.
- If not using IO-Link, connect the sensor to 10...30 V DC.
- The blue supply voltage indicator lights up.
- Adjust the sensor so that the light spot strikes the object to be detected/measured.



## ⚠ DANGER

### Risk of personal injury or property damage due to electric current.

Voltage-conducting parts may cause personal injury or damage to equipment.

→ The electric device may be connected by appropriately qualified personnel only.

241

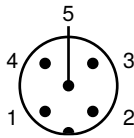
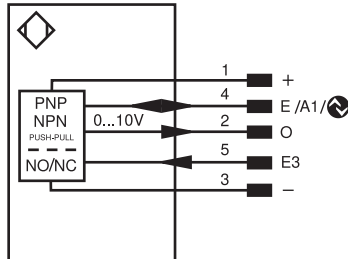

1	Brown	2	White
3	Blue	4	Black
5	Gray		

#### Legend







+	Supply Voltage +
-	Supply Voltage 0 V
~	Supply Voltage (AC Voltage)
A	Switching Output (NO)
Ā	Switching Output (NC)
V	Contamination/Error Output (NO)
∇	Contamination/Error Output (NC)
E	Input (analog or digital)
T	Teach Input
Z	Time Delay (activation)
S	Shielding
RxD	Interface Receive Path
TxD	Interface Send Path
RDY	Ready
GND	Ground
CL	Clock
E/A	Output/Input programmable
	IO-Link
PoE	Power over Ethernet
IN	Safety Input
OSSD	Safety Output
Signal	Signal Output
Bl_D+/-	Ethernet Gigabit bidirect. data line (A-D)
EN0 RS422	Encoder 0-pulse 0-0̄ (TTL)

PT	Platinum measuring resistor
nc	not connected
U	Test Input
Ū	Test Input inverted
W	Trigger Input
W-	Ground for the Trigger Input
O	Analog Output
O-	Ground for the Analog Output
BZ	Block Discharge
AW	Valve Output
a	Valve Control Output +
b	Valve Control Output 0 V
SY	Synchronization
SY-	Ground for the Synchronization
E+	Receiver-Line
S+	Emitter-Line
±	Grounding
SnR	Switching Distance Reduction
Rx+/-	Ethernet Receive Path
Tx+/-	Ethernet Send Path
Bus	Interfaces-Bus A(+)/B(-)
La	Emitted Light disengageable
Mag	Magnet activation
RES	Input confirmation
EDM	Contacting Monitoring

ENARs422	Encoder A/Ā (TTL)
ENBRs422	Encoder B/B̄ (TTL)
ENA	Encoder A
ENB	Encoder B
AMIN	Digital output MIN
AMAX	Digital output MAX
AOK	Digital output OK
SY In	Synchronization In
SY OUT	Synchronization OUT
QLT	Brightness output
M	Maintenance
rsv	reserved
Wire Colors according to IEC 60757	
BK	Black
BN	Brown
RD	Red
OG	Orange
YE	Yellow
GN	Green
BU	Blue
VT	Violet
GY	Grey
WH	White
PK	Pink
GYE	Green/Yellow

## 5.3 Diagnosis

Indicator	Status	Meaning
Power LED		Sensor ready for operation
P		No voltage supply
		<b>Warning</b> LEDs for switching status indicators A1, A2 and analog display O are still working properly

Indicator	Status	Meaning
		<b>Error</b> LEDs for switching status indicators A1, A2 and analog display O are not working properly
		Sensor ready for Bluetooth connection
Switching status indicator A1, A2		Switching outputs active
		Switching outputs not active
Analog indicator O		Object within set measuring range
		Object outside set measuring range
Localization		Localization function active

 = not lit

 = permanently lit

 = flashing

## 5.4 Troubleshooting

Error	Possible cause	Elimination
Warning	Warning signal	<ul style="list-style-type: none"> <li>Reduce distance between sensor and object</li> <li>Adjust angle of sensor to object</li> </ul>
	Undervoltage	<ul style="list-style-type: none"> <li>Increase voltage supply to min. 18 V DC</li> </ul>
Error	Short circuit	<ul style="list-style-type: none"> <li>Check the electrical wiring and eliminate the short circuit</li> </ul>
	Temperature error	<ul style="list-style-type: none"> <li>Disconnect the sensor from the supply voltage and allow it to cool</li> <li>Mount the mounting bracket as a heat sink</li> <li>Reduce load on outputs</li> </ul>
	Device error	<ul style="list-style-type: none"> <li>Disconnect the sensor from the supply voltage and restart it</li> <li>Replace the sensor</li> </ul>

Via IO-Link, it is possible to identify the respective causes precisely by means of condition monitoring. Further diagnosis functions and status messages are also possible. See section Condition Monitoring/Process Data [▶ 36].



### INFORMATION

#### Required action in case of fault:

1. Shut down the machine.
2. Analyze and eliminate the cause of error with the aid of the diagnostics information.
3. If the error cannot be eliminated, please contact wenglor's support department.
4. Do not operate in case of indeterminate malfunctioning.
5. The machine must be shut down if the error cannot be definitively explained or properly eliminated.



## **DANGER**

### **Risk of personal injury or property damage in case of non-compliance!**

The system's safety function is disabled. Personal injury and damage to equipment may occur.

→ Required action as specified in case of fault.

---

# 6 Settings

The sensor can be adjusted via teach-in, IO-Link, wTeach2 and weCon. The different setting options are outlined below.

## 6.1 Configuration with Push of Button / Teach-In

This section describes the settings that can be configured directly on the sensor using the button.

### switching output

#### teach-in

Various teach-in modes are available. These can be set via IO-Link (see section Parameters [▶ 36]). The default setting is foreground teach-in.



#### teach-in for A1

1. Adjust the sensor so that the light spot strikes the object to be taught in.
2. Press and hold the teach-in key or enter button for 2 seconds until LED A1 starts flashing.
3. Release the teach-in key or Enter button.
4. The distance is taught in and the LED A1 flashes twice briefly to confirm successful teaching.



### INFORMATION

When teaching in, if there is no object or the object is too far from the sensor, the switching distance is set to the end of the setting range. The Power LED lights up yellow, and the switching status LEDs for the respective switching output flash twice. The same applies to an object that is too close; here, the switching distance is set to the start of the setting range. If there is an error during teach-in preventing it from being carried out, this is indicated by a red LED.

### Analog Output

#### Analog Output Function

The sensor reads out its measured value as a linear proportional current or voltage value. The characteristic curve can be set within the entire measuring range.

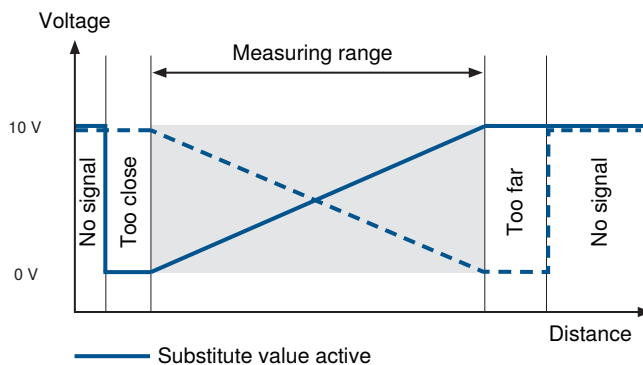

# 7 Settings via menu

This section describes the settings that can be configured via the integrated OLED display. The menu is controlled by pressing the Enter button.



The currently measured distance is shown in display mode.

## Menu control

Press the Enter button to navigate through the menu and make settings.

Short press in display mode	Jump to the menu
Short keystroke	Next menu item
Press button for 2 sec.	Selection
Press button for 5 sec.	Exit the menu, display mode



## Menu structure

The menu is divided into 2 areas. Various sensor status messages are displayed in the Info menu. The Info menu is also used to open the main menu where the settings can be made.

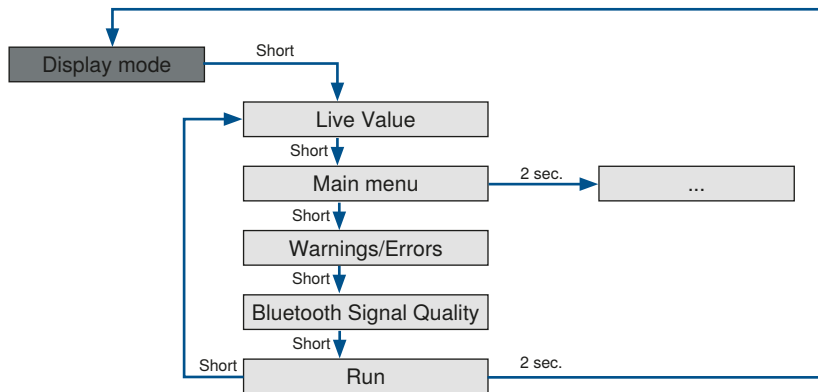
### Info menu



Live value		This display is shown after jumping to the Info menu. The currently measured distance is displayed in combination with the measured value unit.
Main menu		Jump to the main menu to make settings

Warnings/Errors		Warnings or errors are displayed in this view
Bluetooth signal quality		The Bluetooth signal quality is displayed in this view.
Display mode		Jump back to the display mode

## Main menu

The respective functions are described in the section Parameters [▶ 36].

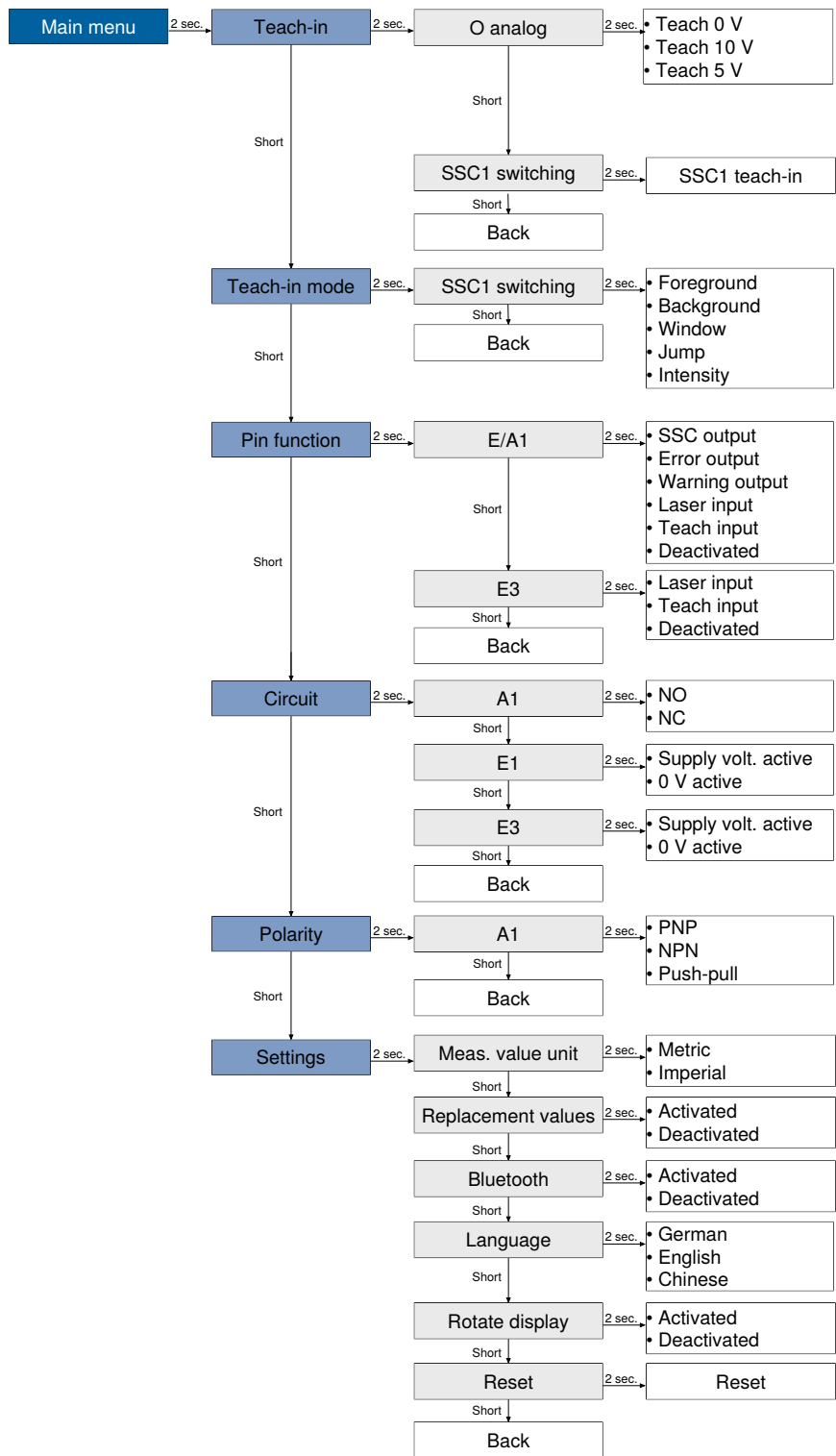

## 8 Function Description

The functions described in the following section can be adjusted via wTeach or IODD per IO-Link, as well as via the weCon app per Bluetooth, and the basic functions via the Display menu.

### 8.1 Sensor Functions

Function	Possible settings	Default
Measuring mode	<p><b>Speed</b> The sensor is optimized for fast applications.</p> <p><b>Precision</b> The sensor is optimized for high-accuracy applications.</p> <p><b>Precision Plus</b> The sensor is optimized for high-accuracy applications and even higher sensitivity to low signals.</p> <p><b>Note!</b> The technical data resulting from the various modes are specified in Mode-Dependent Data [► 11].</p>	Precision
Detection mode	<p><b>First Object</b> The signal reflected by an object that is within the working range and closest to the sensor is used.</p> <p><b>Last Object</b> The signal reflected by an object that is within the working range and farthest from the sensor is used.</p> <p><b>Highest Intensity</b> The signal with the highest signal strength is used.</p> <p><b>Note!</b> If an object is hidden by this function, a blind spot directly behind the object results. The sensor cannot detect any objects within this blind spot. The size of the blind spot depends on the reflectance of the interfering object.</p>	First object
Distance range	<p>A distance range in which signals are to be evaluated can be defined within the working range. Signals outside the set distance range are ignored and are not included in the signal evaluation. This means that ranges for which no usable signals are expected can be completely hidden.</p> <p>This function can be used to suppress interfering signals, such as those produced by a glass disk, for instance. Depending on the set mode and the resulting working range, the distance range can be set within it.</p> <p><b>Min. distance: working range</b></p> <p><b>Max. distance: working range</b></p> <p><b>Note!</b></p> <ul style="list-style-type: none"> <li>• Objects outside the set distance range are evaluated as “No signal”.</li> <li>• If a distance range is set, a blind spot directly behind this range results. The sensor cannot detect any objects within the blind spot. The size of the blind spot depends on the reflectance of the interfering objects in the hidden area.</li> </ul>	Setting range

Function	Possible settings	Default																																																
Sensitivity	<p>The sensor has very high sensitivity and can detect objects with very weak signals and measure distances to them. Constant interferences in the measured section, e.g., due to fog or dust, can result in incorrect measurements. Such interfering influences can be suppressed by reducing the sensitivity. Reducing the sensitivity also reduces the working range.</p> <p><b>Maximum</b></p> <p>In this setting, the working range corresponds to the values specified in the data sheet.</p> <p><b>Medium</b></p> <p>With this setting, the working range changes to: white (90% remission): 10,000 mm, gray (18% remission): 8,000 mm, black (6% remission): 5,000 mm</p> <p><b>Low</b></p> <p>With this setting, the working range changes to: white (90% remission): 9,000 mm, gray (18% remission): 5,000 mm, black (6% remission): 3,000 mm</p> <p><b>Minimum</b></p> <p>With this setting, the working range changes to: white (90% remission): 6,000 mm, gray (18% remission): 3,000 mm, black (6% remission): 1,800 mm</p> <p>The technical data relating to reproducibility and linearity correspond to the typical data sheet values in the various settings.</p>	Maximum																																																
Interference filter	<p>The interference filter can be used to increase measurement reliability in the case of brief interferences in the measured section. Interferences such as rain, snow or chips in the air generate brief signals, which can result in incorrect measurements. A higher filter level allows the interfering signals to be ignored for a defined period. If the distance changes suddenly, the response time is extended. This extension of the response time depends on the filter level and the mode used. If the distance changes continuously, the response time remains unchanged when the filter is activated.</p> <table border="1"> <thead> <tr> <th></th> <th colspan="3">Mode</th> </tr> <tr> <th>Filter</th> <th>Speed</th> <th>Precision</th> <th>Precision Plus</th> </tr> </thead> <tbody> <tr> <td>Off</td> <td>-</td> <td>-</td> <td>-</td> </tr> <tr> <td>1</td> <td>2 ms</td> <td>10 ms</td> <td>20 ms</td> </tr> <tr> <td>2</td> <td>4 ms</td> <td>20 ms</td> <td>40 ms</td> </tr> <tr> <td>3</td> <td>6 ms</td> <td>30 ms</td> <td>60 ms</td> </tr> <tr> <td>4</td> <td>10 ms</td> <td>50 ms</td> <td>100 ms</td> </tr> <tr> <td>5</td> <td>20 ms</td> <td>100 ms</td> <td>200 ms</td> </tr> <tr> <td>6</td> <td>40 ms</td> <td>200 ms</td> <td>400 ms</td> </tr> <tr> <td>7</td> <td>60 ms</td> <td>300 ms</td> <td>600 ms</td> </tr> <tr> <td>8</td> <td>100 ms</td> <td>500 ms</td> <td>1,000 ms</td> </tr> <tr> <td>9</td> <td>200 ms</td> <td>1,000 ms</td> <td>2,000 ms</td> </tr> </tbody> </table>		Mode			Filter	Speed	Precision	Precision Plus	Off	-	-	-	1	2 ms	10 ms	20 ms	2	4 ms	20 ms	40 ms	3	6 ms	30 ms	60 ms	4	10 ms	50 ms	100 ms	5	20 ms	100 ms	200 ms	6	40 ms	200 ms	400 ms	7	60 ms	300 ms	600 ms	8	100 ms	500 ms	1,000 ms	9	200 ms	1,000 ms	2,000 ms	Off
	Mode																																																	
Filter	Speed	Precision	Precision Plus																																															
Off	-	-	-																																															
1	2 ms	10 ms	20 ms																																															
2	4 ms	20 ms	40 ms																																															
3	6 ms	30 ms	60 ms																																															
4	10 ms	50 ms	100 ms																																															
5	20 ms	100 ms	200 ms																																															
6	40 ms	200 ms	400 ms																																															
7	60 ms	300 ms	600 ms																																															
8	100 ms	500 ms	1,000 ms																																															
9	200 ms	1,000 ms	2,000 ms																																															
Emitted light	<p>The sensor's laser can be switched on or off.</p> <p><b>On</b></p> <p>Laser on</p> <p><b>Off</b></p> <p>Laser off</p>	On																																																

	<p>The sensor no longer supplies a measured value.</p> <p><b>Note!</b></p> <ul style="list-style-type: none"> <li>• If an input is set as a laser-off input, the emitted light can also be switched on and off via the input.</li> <li>• If the laser is switched off, the sensor behavior corresponds to the status “No signal.”</li> </ul>	
Localization	<p>The sensor's supply voltage indicator can be set to flash green. This makes it easy to locate the sensor in a system.</p> <p><b>On</b></p> <p>The supply voltage for the LED flashes green.</p> <p><b>Off</b></p> <p>LEDs in normal operation.</p>	Off
Measured value unit	<p>The measured distance can be read out in millimeters or inches.</p> <p><b>Millimeter</b></p> <p>Distance values read out in mm</p> <p><b>Inch</b></p> <p>Distance values read out in 1/10 inch</p>	Millimeter
Bluetooth	<p>The Bluetooth interface can be switched on/off.</p> <p><b>On</b></p> <p><b>Off</b></p>	On
Bluetooth Password Function	<p>The Bluetooth function can be password protected to prevent unauthorized access.</p> <p><b>On</b></p> <p><b>Off</b></p> <p><b>Note!</b></p> <p>Only the Bluetooth function is protected. Communication is possible via IO-Link or the OLED menu at any time.</p>	Off
Bluetooth Password	<p>Enter a Bluetooth password. To access the device using the Bluetooth app, enter this password in the app.</p> <p><b>Note!</b></p> <p>If the password has been forgotten, a new password can be assigned via IO-Link.</p>	–

## 8.2 Display Functions

Function	Possible settings	Default
Language	<p>Selecting the display language</p> <p><b>German</b></p> <p><b>English</b></p> <p><b>Chinese</b></p>	English
Rotate display	<p>Rotates the display 180°.</p> <p><b>On</b></p> <p><b>Off</b></p>	Off

## 8.3 Input/Output Functions (E/A)

### 8.3.1 Pin Function

The pin function is used to define the function of pins E/A1 and E3, as these can be used for different functions.

Pin	Possible settings	Default
E/A1	<p><b>Switching output</b> Switching point SSC1 is assigned to the switching output.</p> <p><b>Error output</b> The error output switches if one of the assigned errors occurs; see table Status messages [▶ 31].</p> <p><b>Warning output</b> The warning output switches if one of the assigned warnings occurs; see table Status messages [▶ 31].</p> <p><b>Laser-off input</b> See E3 for an explanation</p> <p><b>Teach-in input</b> See E3 for an explanation</p> <p><b>Speed measurement reset input</b> See E3 for an explanation</p> <p><b>Deactivated</b> The pin is deactivated.</p>	Switching output
E3	<p><b>Laser-off input</b> The sensor's emitted light is deactivated as long as the input is activated. The sensor then does not send a measured value and sets the status to "No signal".</p> <p><b>Teach-in input</b> Teach-in The outputs can be set by following the same procedure as with the Teach-in key (see section Configuration with Push of Button / Teach-In [▶ 19]). An activated input corresponds to a depressed Teach-in key.</p> <p><b>Locking</b> If 18...30 V DC is continuously applied to the teach-in input, the teach-in key is locked and protected against inadvertent changes, like the input signal.</p> <p><b>Speed measurement reset input</b> The status message "Speed" is reset.</p> <p><b>Deactivated</b> The pin is deactivated.</p>	Laser off Input

### 8.3.2 Output Functions

The output functions are used to set the physical outputs.

#### Digital Outputs

Function	Possible settings	Default
Polarity	PNP	PNP

Function	Possible settings	Default
	<b>NPN</b> <b>Push-pull</b>	
Circuit	<b>NO</b> Light switching (Normally Open) The output is high when the condition has been satisfied, depending on settings (switching point, warning, error). <b>NC</b> Dark switching (normally closed) The output is low when the condition has been fulfilled depending on the setting (switching point, warning, error).	NO
On-delay	<b>0...10,000 ms</b>	0 ms
Off-delay	<b>0...10,000 ms</b>	0 ms

### Analog outputs

Function	Possible settings	Default
0 V	The 0 V value is assigned to a distance within the measuring range. <b>measuring range</b>	50 mm
10	The 10 V value is assigned to a distance within the measuring range. <b>measuring range</b>	10,000 mm
Analog Replacement values	The substitute values described in the section Settings – Analog output can be activated or deactivated. <b>Enabled</b> Sensor outputs substitute values. <b>Deactivated</b> Sensor does not use substitute values. <b>Note!</b> Function can only be used for current output.	Enabled

## 8.3.3 Input Functions

The input functions are used to set the physical inputs.

Function	Possible settings	Default
Input mode	<b>Supply voltage active</b> Function is triggered as soon as supply voltage is applied to the input. <b>Supply voltage inactive</b> Function is triggered as soon as 0 V is applied to the input or the input is opened.	Supply voltage active

## 8.4 Switching Point Functions (SSC1/SSC2)

The switching point functions are used to set the two switching points, SSC1 and SSC2.

SSC1 and SSC2 initially only available via IO-Link. If E/A1 is configured as a switching output, SSC1 is assigned to it.

Function	Possible settings	Default
Teach-in	Starts the teach-in process.	

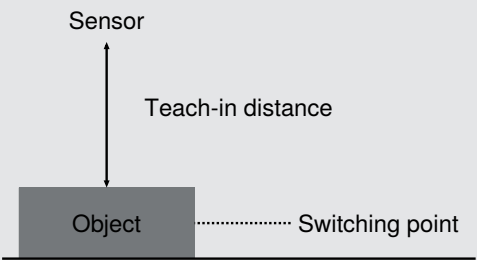
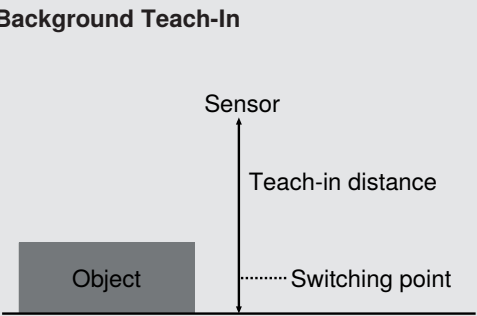
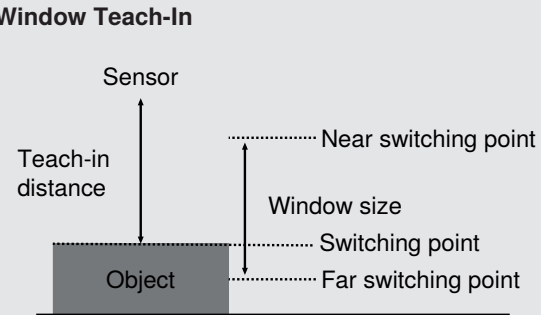
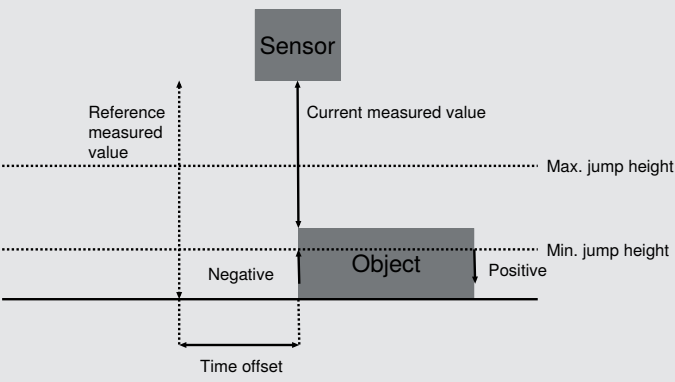
Function	Possible settings	Default
Teach-in mode	<p><b>Foreground Teach-In</b></p>  <p><b>Background Teach-In</b></p>  <p><b>Window Teach-In</b></p>  <p><b>Jump Detection</b></p> <p>In this mode, there is no switch to an absolute measured value, but rather to a measured value jump occurring between 2 measurements.</p>  <p><b>Distance and Intensity</b></p>	Foreground teach-in

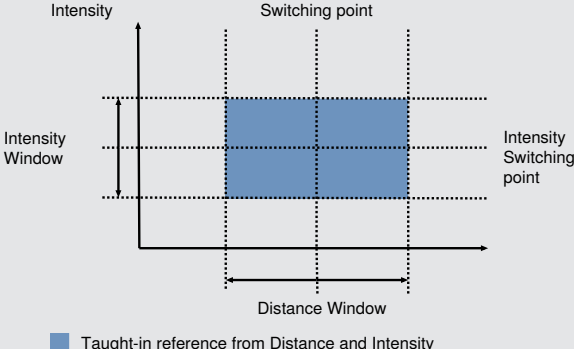
Function	Possible settings	Default
	<p>In this mode, the intensity of the received signal is also evaluated for distance. The sensor is taught in a reference that consists of a switching point for the distance and a switching point for the intensity. As soon as the sensor detects a deviation in distance or intensity, this is registered via the output.</p>  <p><b>Note!</b> The teach-in function is necessary to ensure that the sensor works properly.</p>	
switching point	50...10,000 mm  <b>Note</b> If a distance range has been set, the switching point can only be set within the set distance range.	5,000 mm
Hysteresis	Hysteresis is the difference between the switch-on and switch-off point. 5...1,000 mm	15 mm
Window switching point close	In teach-in mode window teach-in Distance from the set window center to the switching point of the window close to the sensor.  The window can be set so that it extends from the minimum setting range to the maximum setting range of the sensor. The minimum and maximum possible settings result from the respective set window center.	
Window switching point far	In teach-in mode window teach-in Distance from the set window center to the switching point of the window far from the sensor.  The window can be set so that it extends from the minimum setting range to the maximum setting range of the sensor. The minimum and maximum possible settings result from the respective window center setting.	
Jump height min	In teach-in mode Jump detection The minimum jump height defines the jump in the measured value at which a jump event is to be detected. In the "Automatic" setting, the sensor calculates the smallest possible jump independently. 0 = Automatic 10...1,000 mm	50
Maximum jump height	In teach-in mode, jump detection The max. jump height defines the maximum jump in the measured value at which a jump event is to be detected. In the "No restriction" setting, there is no limit to the max. jump height. A change from a valid measured value to "No measured value" is evaluated as a negative jump.	1,000 mm

Function	Possible settings	Default
	4294967295 = No restriction 0...100.000 mm	
Jump direction	In teach-in mode, jump detection <b>Positive</b> A jump is detected when the measured value jumps to a higher value, i.e. the contrast value becomes brighter. <b>Negative</b> A jump is detected when the measured value jumps to a lower value, i.e. the contrast value becomes darker. <b>Both</b> A jump is detected for both positive and negative.	Negative
Cycle offset	In teach-in mode Jump detection The cycle offset specifies the time-shifted reference measurement value with which the current measured value is to be compared in order to detect the jump. 1...64 Cycles	10
Jump pulse duration	In teach-in mode Jump detection <b>0 = hold</b> The output remains active until the next jump in the opposite direction is detected. 1...1.000 ms When a jump is detected, the output is activated with the corresponding pulse length.	0
Distance Window	In teach-in mode Distance + Intensity Distance from the set switching point (center of the window) to the boundaries of the window. The distance window is symmetrical around the switching point. 0...300 mm	50 mm
Switching point Intensity	In teach-in mode Distance + intensity Switching point of intensity in digits 0...255	200
Intensity window	In teach-in mode, distance + intensity from the set switching point intensity (center of the window) to the limits of the window. The intensity window is symmetrical around the switching point. 0...255	5%
Intensity hysteresis	In teach-in mode, distance + intensity 0...255	5

## 8.5 Condition Monitoring Functions

### 8.5.1 Status Message Function

The sensor provides various status messages. Due to the process data structure, four status messages can be transmitted as individual process data.

These parameters can be used to set the status messages that are transmitted via the process data.

Function	Possible settings	Default
Message 1	See table "Status Messages" [▶ 31]	Warning signal
Message 2	See table "Status Messages" [▶ 31]	Optics dirty
Message 3	See table "Status Messages" [▶ 31]	Ambient light
Message 4	See table "Status Messages" [▶ 31]	Temperature too high

## 8.5.2 Warning/Error Output Function

The status messages used to trigger the collective message can be defined for the warning output and the error output respectively. The status messages are OR-linked so that the output is activated when one of the defined status messages is activated.

Function	Possible settings	Default
Warning output	See table "Status Messages"	Signal warning, optics dirty, ambient light, temperature too high, temperature too low, undervoltage, interference in the working range
Error output	See table "Status Messages"	Object too close, object too far, no signal, device error, over-temperature, short circuit

### Status Messages

Warning	
Undervoltage	The supply voltage is too low.
Signal warning	The signal received is too low.
Contaminated optics	The sensor detects when the optic cover is dirty, and the signal deteriorates as a result
Ambient light	Object detection is impeded by ambient light.
Interference in the working range	When using the interference filter, the sensor detects whether a brief interfering event has occurred in the measuring range. This could be chips, water droplets, etc., for instance.
Temperature too high	The sensor's internal temperature is high.
Temperature too low	The sensor's internal temperature is low.
Device warning	An internal device error has occurred.
Emitted light off	The sensor's emitted light is switched off.

Error	
Short circuit	A short circuit has occurred on at least one pin.
No signal	The sensor is not receiving a signal.
Object too close	The object is below the setting range or the set measuring range.
Object too far	The object is above the setting range or the set measuring range.
Over-temperature	The over-temperature has been exceeded. To protect the emitting unit, the laser is switched off.
Device error	A hardware error has occurred. For safety reasons, the emitted light is switched off.

Speed measurement	
Overspeed detected	The sensor has detected a speed above the set threshold via the internal speed measurement.

### 8.5.3 Speed Measurement

The sensor has an integrated speed measurement function. This detects the speed of objects approaching or moving axially away from the sensor.

Function	Possible settings	Default setting
Speed measurement	<p><b>On</b> Speed measurement activated</p> <p><b>Off</b> Speed measurement deactivated</p> <p>A status message is triggered if the set threshold is exceeded. This can be linked to the warning or error output and thus trigger a corresponding switching signal (see section Warning/Error Output Function [► 31]).</p>	On
Speed Threshold	<p>The threshold defines how sensitively the speed measurement reacts</p> <p><b>0...30.000</b></p>	50
Speed filters	<b>0...300</b>	300
Speed hysteresis	<b>1...60.000</b>	10
Approach direction	<p>The direction of approach defines the direction of movement of the object in relation to the sensor at which the set threshold triggers the status message.</p> <p><b>Approach</b> <b>Move away</b> <b>Both</b></p>	Both

### 8.5.4 Signal Monitoring

The sensor can detect up to four objects in its working range. A distance and signal strength are determined for each of these objects.

Function	Possible settings	Default
Signal monitoring	<p><b>On</b> Signal observation activated</p> <p><b>Off</b> Signal observation deactivated</p>	Off
Object detection status	<p>Indicates the object used for signal evaluation.</p> <p><b>Object 1–4</b></p>	—
Object distance	<p>Indicates the respective distance from a maximum of four objects.</p> <p>50...10,000 mm</p>	—
Object signal	<p>Indicates the respective signal strength of a maximum of four objects.</p> <p><b>1...1,000</b></p>	—

### 8.5.5 Simulation Functions

This function simulates the behavior of the sensor regardless of the current status and measured value. This can be used to check whether a plant in which the sensor is integrated reacts correctly to the data supplied by the sensor and processes them accordingly.

If a measured value is specified, the sensor behaves as if the specified measured value corresponds to the actual measured value. This means that the behavior of the outputs and status messages is simulated according to the specified measured value.

In addition, the individual outputs and status messages can be simulated separately from the measured value.

Function	Possible settings	Default
Simulation mode	<b>On</b> <b>Off</b>	Off
Test measured value	Current measured value min...max. measuring range	Current measured value
Output O test	According to the measured value 0...10 V	According to the measured value
SSC1 Test	According to the measured value <b>On</b> <b>Off</b>	According to measured value
SSC2 Test	According to the measured value <b>On</b> <b>Off</b>	According to measured value
Status messages test	Tests the individual status messages according to the measured value <b>On</b> <b>Off</b>	According to measured value



## INFORMATION

Output A1 is used for IO-Link communication in this function and cannot be simulated.  
Simulation mode ends automatically as soon as the power supply is interrupted.

# 9 Bluetooth

These sensors have an integrated Bluetooth interface. This interface can be used to configure and parameterize devices using a smartphone and the wenglor “weCon” app. In addition, process data is sent to the app, where it is displayed in a clear, concise manner.

## 9.1 weCon Installation

The wenglor app can be downloaded free of charge from the Google Play Store and Apple App Store. Download the app and follow the installation instructions.



Scan the code below to access the wenglor app directly.

## 9.2 Establishing Connection with Sensor

Open the weCon app on your smartphone.

When the app is opened, all wenglor sensors with Bluetooth interface and within range are set to Pairing mode.

This mode is indicated by the flashing blue LED on the sensors.

Pairing mode is used to pair the app with a corresponding sensor.

Once the app is opened, a list of all sensors within range is shown.

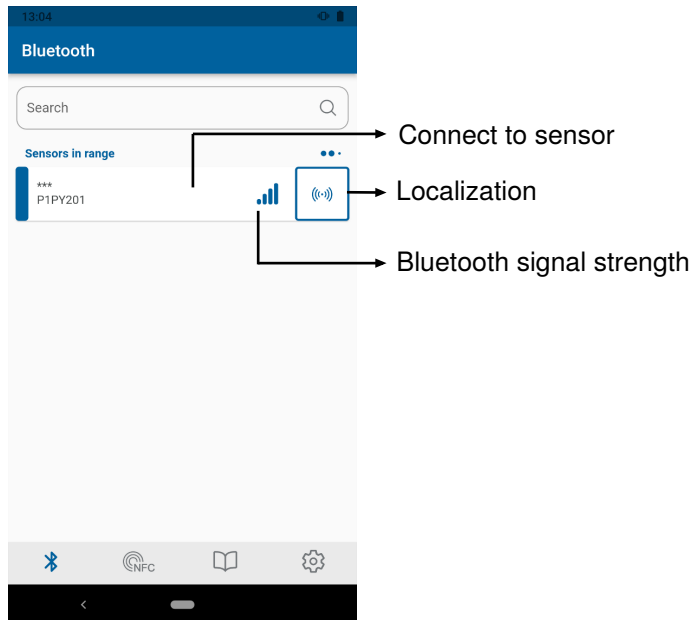

If too many sensors of the same type are fitted within the Bluetooth range, the sensor’s supply voltage LEDs can be switched to flashing green by pressing the “Localization” button. This simplifies identification.

Press the “Back” button to open the sensor list again. Pressing the “Connect with sensor” button establishes a connection to the sensor and opens the user interface.

The blue LED will continuously illuminate from now on, indicating that the sensor is paired, and Pairing mode will deactivate.

## 9.3 Using the weCon App

The sensor parameters are configured using the “Configuration” tab. A detailed description of the individual parameters can be found in section “Function overview”.

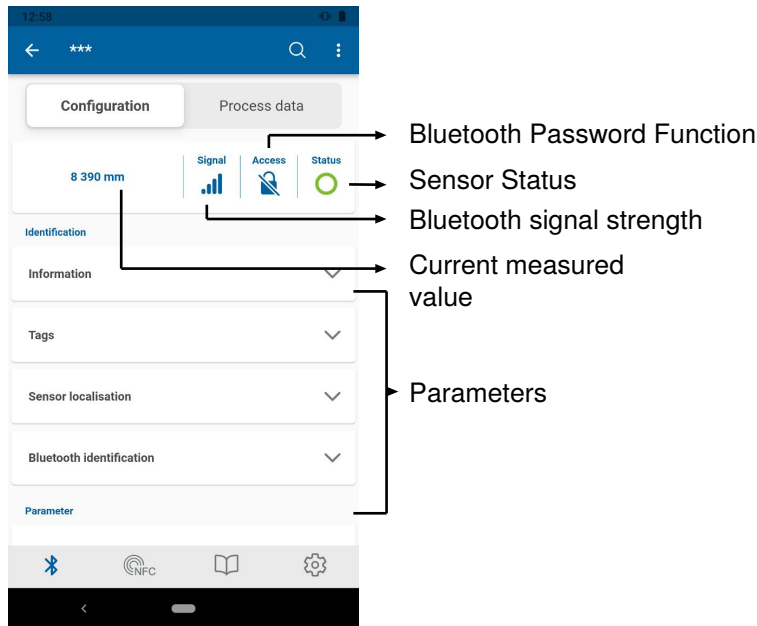

The “Process Data” tab shows the current measured value, visualizing this value over time in a diagram. The axis scaling can be adjusted in the diagram settings.

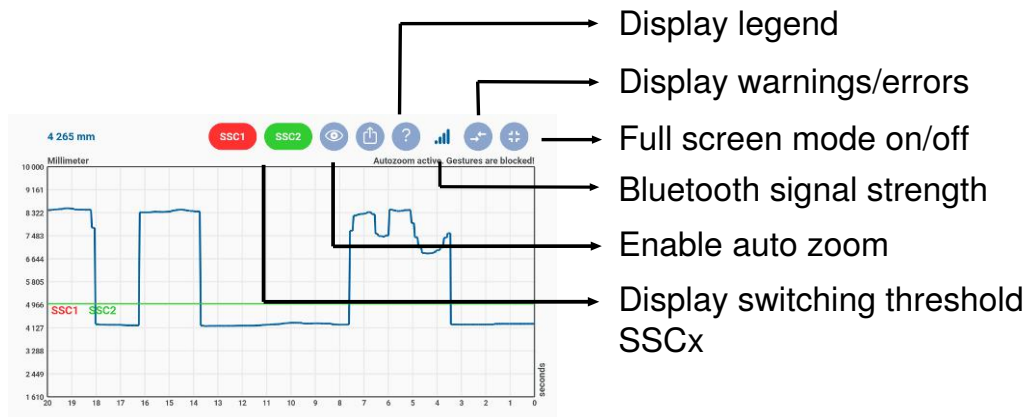

### NOTICE

The Bluetooth range is approx. 10 m. If the sensor is encapsulated in a system or set up close to obstacles, the range may decrease accordingly.

# 10 IO-Link

The sensors can exchange parameters and process data via IO-Link. The parameters can be used to make many additional settings on the device. The process data transmit cyclical data and condition monitoring.

To this end, the sensor is connected to a suitable IO-Link master (see product detail page/complementary products). The interface protocol and the IODD can be found at [www.wenglor.com](http://www.wenglor.com) in the download area for the respective product.

## 10.1 Parameters

The parameters that can be configured via IO-Link are given in the functional description in the section Function description [▶ 23].

## 10.2 Condition Monitoring/Process Data

The data described in the following section can be read or written cyclically via IO-Link/process data.

### 10.2.1 Process Data In

Data	Meaning
Measured value	Measured distance in mm or 1/10 inch As the sensor cannot determine a measured value in the following error cases, substitute values are read out: No signal: 0x7FFC / 32764 mm Object too close: 0x8008 / -32760 mm Object too far: 0x7FF8 / 32760 mm
Scale	Scaling of the measured value to the base length unit; -3 corresponds to mm.
SSC1	Switching point 1
SSC2	Switching point 2
Warning	Collective warning in the event of one of the warning status messages (see table "Status messages") in the error output function)
Error	Collective warning in the event of one of the error status messages (see table "Status messages") in error output function.
Message 1	Status message 1 read out see Status Message Function [▶ 30]
Message 2	Status message 2 read out see Status Message Function [▶ 30]
Message 3	Status message 3 read out see Status Message Function [▶ 30]
Message 4	Status message 4 read out see Status Message Function [▶ 30]

### 10.2.2 Process Data Out

Data	Meaning
Emitted light	Transmit signal on/off
Localization	Sensor flashes for easy sensor location
Teach-in SSC1	Starts the teach-in process for SSC1
Teach-in SSC2	Starts the teach-in process for SSC2

### 10.2.3 Events

Events are diagnostic information that is standardized by IO-Link and exchanged between the IO-Link master and the device. The following events are supported:

Name	Event code	Type	Specification
Maintenance necessary: Clean	0x8C40	Notification	IO-Link
Device error – unknown error	0x1000	Error	IO-Link
Short circuit – check installation	0x7710	Error	IO-Link
Device temperature too high: Remove heat source	0x4210	Warning	IO-Link
Device temperature too low: Isolate device	0x4220	Warning	IO-Link
Temperature error: Overload	0x4000	Error	IO-Link
Supply voltage too low – check tolerances	0x5111	Warning	IO-Link
Speed measurement	0x1801	Warning	wenglor-specific

# 11 wTeach2 Configuration Software

For information on installing and connecting the wTeach2 software and its structure, as well as information on the general functions, see the wTeach2 operating instructions. They can be found online in the download area at [www.wenglor.com](http://www.wenglor.com) under order number DNNF005.

## 12 Maintenance Instructions



### NOTICE

This wenglor product is maintenance-free.

Cleaning and inspection of the plug connections at regular intervals are advisable.

Do not clean the product with solvents or cleaning agents that could damage the product.

The product must be protected against contamination during initial start-up.

---

## 13 Proper Disposal

wenglor sensoric GmbH does not accept the return of unusable or irreparable products. Respectively valid national waste disposal regulations apply to product disposal.

## 14 **Declarations of Conformity**

Declarations of conformity can be found on our website at [www.wenglor.com](http://www.wenglor.com) in the product's separate download area.