

Operating Instructions

P1XD001

Fiber-optic amplifier



EN



Table of Contents

1	General	3
1.1	Information Concerning these Instructions.....	3
1.2	Explanation of Symbols.....	3
1.3	Limitation of Liability.....	4
1.4	Copyrights.....	4
2	For Your Safety	5
2.1	Use for Intended Purpose.....	5
2.2	Use for Other than the Intended Purpose.....	5
2.3	Personnel Qualifications.....	5
2.4	Modification of Products.....	6
2.5	General Safety Precautions	6
2.6	Approvals and Protection Class	6
3	Technical Data	7
3.1	General Data	7
3.2	Housing Dimensions	8
3.3	Control Panel.....	8
3.4	Complementary Products	8
3.5	Scope of delivery	8
4	Transport and Storage	9
4.1	Transport	9
4.2	Storage	9
5	Installation and Electrical Connection	10
5.1	Installation	10
5.1.1	Mounting on a DIN Rail.....	10
5.1.2	Removal.....	11
5.1.3	Side Mounting (Using Optional Accessories).....	11
5.1.4	Connecting Plastic Fiber-Optic Cables	12
5.2	Electrical Connection	13
5.3	Diagnosis	14
6	Settings	16
6.1	Adjustment via Potentiometer.....	16
6.2	Setting via IO-Link and wTeach2	16
7	Function Description	17
7.1	Sensor Functions.....	17
7.2	Output Functions	17
7.3	Pin Function	18
7.4	Switching Point Functions (SSC1).....	18
8	IO-Link	19
9	wTeach2 Configuration Software	20
10	Maintenance Instructions	21
11	Proper Disposal	22
12	Declarations of Conformity	23

1 General

1.1 Information Concerning these Instructions

- These instructions make it possible to use the product safely and efficiently.
- These instructions are an integral part of the product and must be kept on hand for the entire duration of its service life.
- Local accident prevention regulations and national work safety regulations must be complied with as well.
- The product is subject to further technical development, and thus the information contained in these operating instructions may also be subject to change. The current version can be found at www.wenglor.com in the product's separate download area.



INFORMATION

The operating instructions must be read carefully before using the product and must be kept on hand for later reference.

1.2 Explanation of Symbols

- Safety precautions and warnings are emphasized by means of symbols and signal words.
- Safe use of the product is only possible if these safety precautions and warnings are adhered to.

The safety precautions and warnings are laid out in accordance with the following principle:

SIGNAL WORD

Type and source of danger!

Possible consequences in the event that the hazard is disregarded.

→ Measures for averting the hazard.

The meanings of the signal words, as well as the scope of the associated hazards, are listed below:



DANGER

This signal word indicates a hazard with a high degree of risk which, if not avoided, results in death or severe injury.



WARNING

This signal word indicates a hazard with a medium degree of risk which, if not avoided, may result in death or severe injury.



CAUTION

This signal word indicates a hazard with a low degree of risk which, if not avoided, may result in minor or moderate injury.



NOTICE

This signal word draws attention to a potentially hazardous situation which, if not avoided, may result in property damage.



INFORMATION

Information draws attention to useful tips and suggestions, as well as information on efficient, error-free use.

1.3 Limitation of Liability

- The product has been developed in consideration of the current state-of-the-art technology, as well as applicable standards and guidelines. Subject to change without notice.
- A valid declaration of conformity can be accessed at www.wenglor.com in the product's separate download area.
- wenglor sensoric elektronische Geräte GmbH (hereinafter referred to as "wenglor") excludes all liability in the event of:
 - Non-compliance with the instructions
 - Use of the product for purposes other than those intended.
 - Use by untrained personnel.
 - Use of unapproved spare parts.
 - Unapproved modification of products.
- These operating instructions do not include any guarantees from wenglor with regard to the described procedures or specific product characteristics.
- wenglor assumes no liability for printing errors or other inaccuracies contained in these operating instructions unless wenglor was verifiably aware of such errors at the point in time at which the operating instructions were prepared.

1.4 Copyrights

- The contents of these instructions are protected by copyright law.
- All rights are reserved by wenglor.
- Commercial reproduction or any other commercial use of the provided content and information, in particular graphics and images, is not permitted without previous written consent from wenglor.

2 For Your Safety

2.1 Use for Intended Purpose

Fiber-Optic Amplifiers

Plastic fiber-optic cables or glass fiber-optic cables can be connected to fiber-optic amplifiers. Universal reflex sensors can be used both with and without fiber-optic cables. Fiber-optic amplifiers evaluate light reflected from the object. The output switches when an object reaches the set detection range (reflex mode operation) or the active light beam is interrupted (through-beam mode). Bright objects reflect more light than dark objects, and can thus be recognized from greater distances. The color of the object has no influence on working range in barrier mode operation.

This Product Can Be Used in the Following Industry Sectors:

- Special-purpose mechanical engineering
- Heavy mechanical engineering
- Logistics
- Automotive industry
- Food industry
- Packaging industry
- Pharmaceuticals industry
- Plastics industry
- Woodworking industry
- Consumer goods industry
- Paper industry
- Electronics industry
- Glass industry
- Steel industry
- Aviation industry
- Chemicals industry
- Alternative energies
- Raw materials extraction

2.2 Use for Other than the Intended Purpose

- Not a safety component in accordance with 2006/42/EC (Machinery Directive).
- The product is not suitable for use in potentially explosive atmospheres.
- The product may be used only with accessories supplied or approved by wenglor, or in combination with approved products. A list of approved accessories and combination products can be found at www.wenglor.com on the product detail page.



DANGER

Risk of personal injury or property damage in case of use for other than the intended purpose!

Use for other than the intended purpose may lead to hazardous situations.

- Observe instructions regarding use for intended purpose.

2.3 Personnel Qualifications

- Suitable technical training is a prerequisite.
- In-house electronics training is required.
- Trained personnel who use the product must have (permanent) access to the operating instructions.



DANGER

Risk of personal injury or property damage in case of incorrect initial start-up and maintenance!

Personal injury and damage to equipment may occur.

→ Adequate training and qualification of personnel

2.4 Modification of Products



DANGER

Risk of personal injury or property damage if the product is modified!

Personal injury and damage to equipment may occur. Noncompliance may result in loss of the CE and/or UKCA mark and voiding of the warranty.

→ Modification of the product is not permitted

2.5 General Safety Precautions



INFORMATION

These instructions are an integral part of the product and must be kept on hand for the entire duration of its service life.

In the event of possible changes, the current version of the operating instructions can be found at www.wenglor.com in the product's separate download area.

Read the operating instructions carefully before using the product.

Protect the sensor against contamination and mechanical influences.

2.6 Approvals and Protection Class

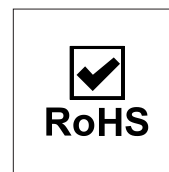
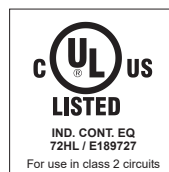

3 Technical Data

3.1 General Data

Technical Data	
Optical Data	
Switching Hysteresis	< 15 %
Light Source	Red Light
Wavelength	633 nm
Service Life (T = +25 °C)	> 100000 h
Max. Ambient Light	10000 Lux
Electrical Data	
Supply Voltage	10 ... 30 V DC
Supply Voltage with IO-Link	18 ... 30 V DC
Current Consumption (U _b = 24 V)	< 30 mA
Switching Frequency	0.9 kHz
Switching frequency (speed mode)	1.8 kHz
On-/Off-Delay	0 ... 200 ms
Temperature Drift	< 10 %
Temperature Range	-25 ... 60 °C
Switching Output Voltage Drop	< 2 V
Switching Output/Switching Current	100 mA
Short Circuit Protection	yes
Reverse Polarity Protection	yes
Overload Protection	yes
Interface	IO-Link V1.1
Baud Rate	COM2
Protection Class	III
Mechanical Data	
Setting Method	Potentiometer
Housing Material	Plastic, PC Plastic, ABS Plastic, PA
Degree of Protection	IP50
Connection	M8 × 1; 4-pin
DIN-Rail mounting	35 mm
Output Functions	
Output	PNP NC+NO
Adjustable Parameters	
Output	Push-pull NPN PNP
Circuit	NC+NO inactive

3.2 Housing Dimensions

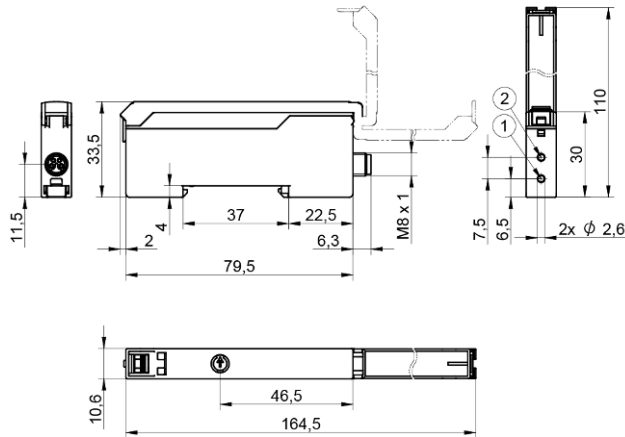

3.3 Control Panel



68 = supply voltage indicator

5a = switching status display, A1

05 = switching distance adjuster

3.4 Complementary Products

wenglor offers you the right connection and mounting technology as well as other accessories for your product. You can find this at www.wenglor.com on the product details page at the bottom.

3.5 Scope of delivery

- Sensor
- Commissioning instructions

4 Transport and Storage

4.1 Transport

Upon receipt of shipment, the goods must be inspected for damage in transit. In the case of damage, conditionally accept the package and notify the manufacturer of the damage. Then return the device, making reference to damage in transit.

4.2 Storage

The following points must be taken into consideration with regard to storage:

- Do not store the product outdoors.
- Store the product in a dry, dust-free place.
- Protect the product against mechanical impacts.
- Protect the product against exposure to direct sunlight.



NOTICE

Risk of property damage in case of improper storage!

The product may be damaged.

→ Storage instructions must be complied with.

5 Installation and Electrical Connection

5.1 Installation

- Protect the product from contamination during installation.
- Observe all applicable electrical and mechanical regulations, standards, and safety rules.
- Protect the product against mechanical influences.
- Make sure that the sensor is mounted in a mechanically secure fashion.
- Specified torque values must be complied with (see section Technical Data [▶ 7]).



NOTICE

Risk of property damage in case of improper installation!

The product may be damaged!

→ Comply with installation instructions.



CAUTION

Risk of personal injury or property damage during installation!

Personal injury and damage to the product may occur.

→ Ensure a safe installation environment.

5.1.1 Mounting on a DIN Rail

Mounting on a DIN rail is tool-free. Hook the sensor onto the DIN rail and push the sensor down until it clicks into place through the integrated spring.

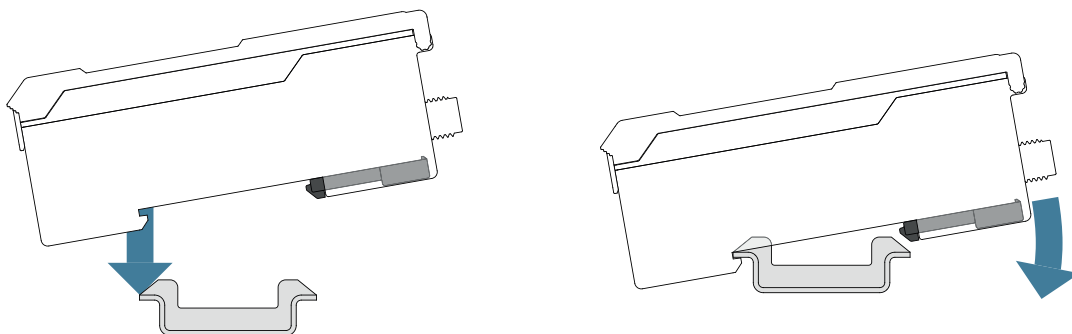

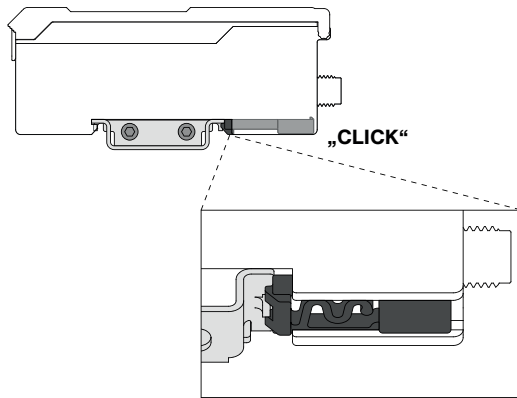

5.1.2 Removal

The sensor can also be removed without tools. Disengage the sensor from the DIN rail by pushing the sensor to the front so that the integrated spring is compressed. This allows you to release the sensor upwards.

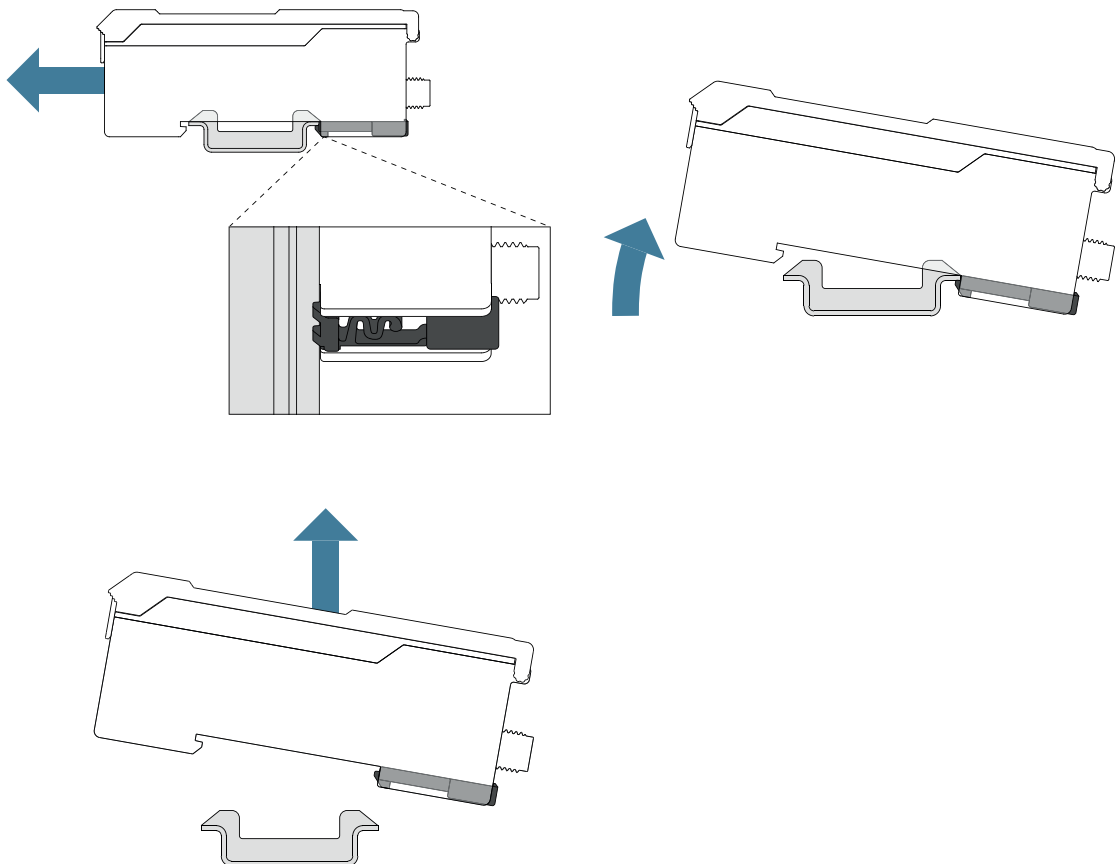

5.1.3 Side Mounting (Using Optional Accessories)

The Z1XZ001 adapter allows the sensor to be mounted on a table or on the side.

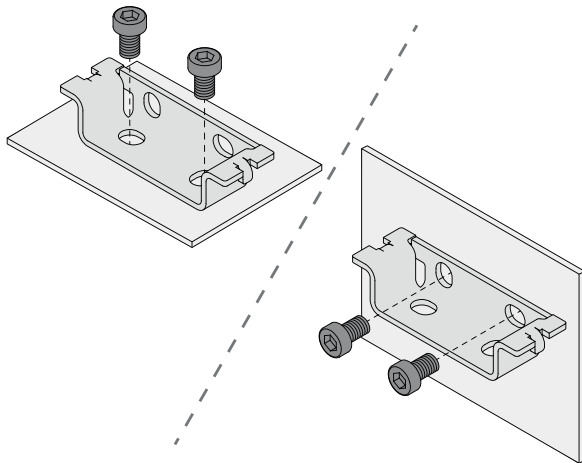

- Fasten the Z1XZ001 adapter with the enclosed mounting set through the mounting holes in the desired position.
- Snap the sensor onto the adapter as described in Mounting on a DIN Rail [▶ 10].

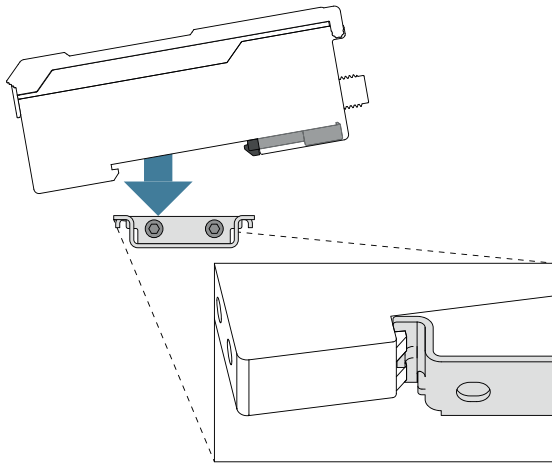

5.1.4 Connecting Plastic Fiber-Optic Cables

- Before first use, shorten the plastic fiber-optic cable once with the SW cutting tool or cut it to the desired length.
- Open the cover and unlock the rocker arm.

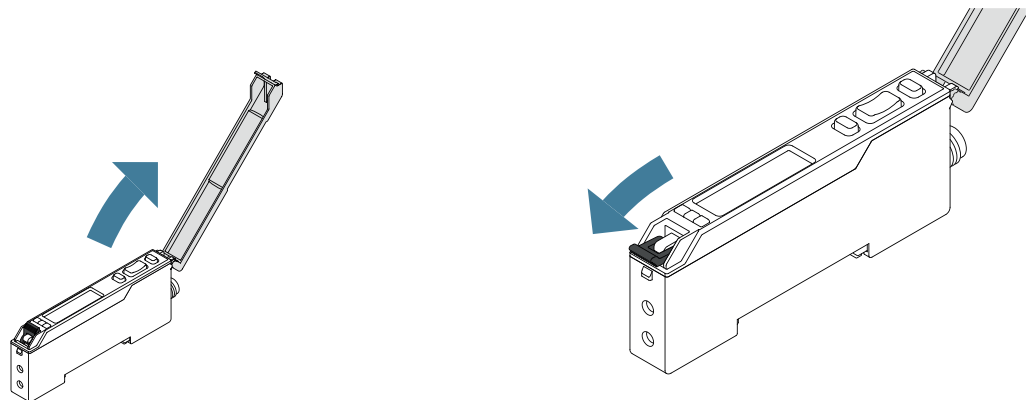

- Insert the fiber-optic cable into the openings provided as far as it will go.

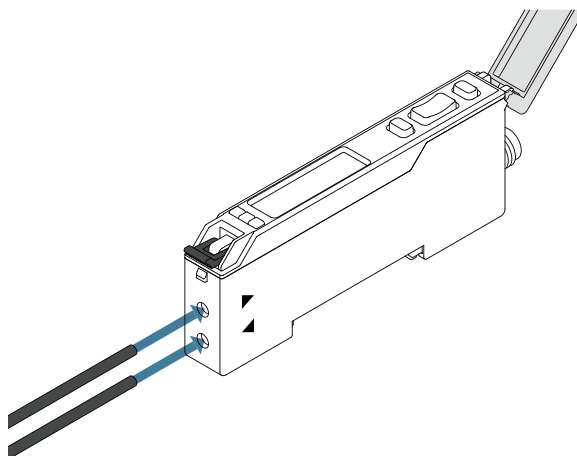

NOTICE

Depending on the fiber-optic cable used, it may be necessary to check how the emitter/receiver is assigned.

- Lock the rocker arm and close the cover.

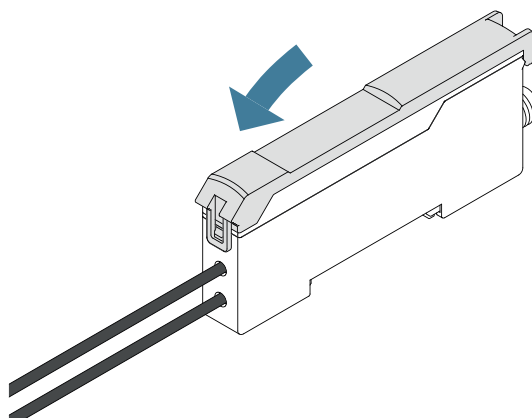
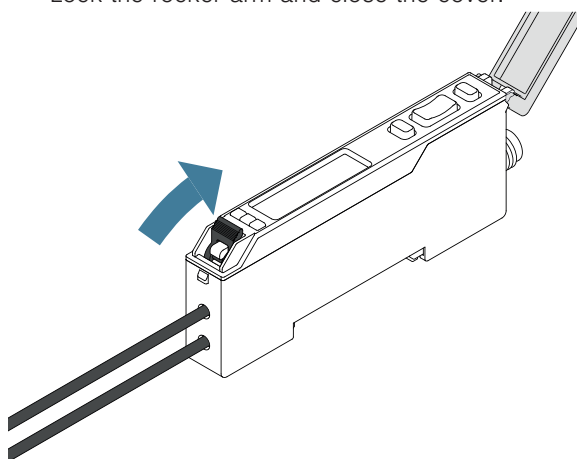

NOTICE

The cover can only be closed when the fiber-optic cable is correctly locked.

5.2 Electrical Connection

- Wire the sensor in accordance with the connection diagram.
- Switch on the supply voltage (see section Technical Data [► 7])
- If using IO-Link, connect the sensor to 18...30 V DC.
- If not using IO-Link, connect the sensor to 10...30 V DC.



DANGER

Risk of personal injury or property damage due to electric current.

Voltage-conducting parts may cause personal injury or damage to equipment.

→ The electric device may be connected by appropriately qualified personnel only.

215

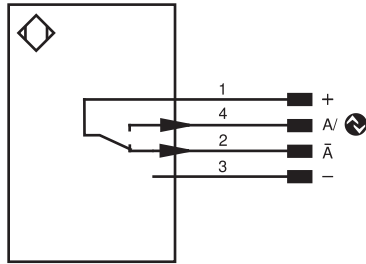

Legend

+	Supply Voltage +
-	Supply Voltage 0 V
~	Supply Voltage (AC Voltage)
A	Switching Output (NO)
Ā	Switching Output (NC)
V	Contamination/Error Output (NO)
ṽ	Contamination/Error Output (NC)
E	Input (analog or digital)
T	Teach Input
Z	Time Delay (activation)
S	Shielding
RxD	Interface Receive Path
TxD	Interface Send Path
RDY	Ready
GND	Ground
CL	Clock
E/A	Output/Input programmable
	IO-Link
PoE	Power over Ethernet
IN	Safety Input
OSSD	Safety Output
Signal	Signal Output
BI_D+/-	Ethernet Gigabit bidirect. data line (A-D)
ENo RS422	Encoder 0-pulse 0-0̄ (TTL)

PT	Platinum measuring resistor
nc	not connected
U	Test Input
Ū	Test Input inverted
W	Trigger Input
W-	Ground for the Trigger Input
O	Analog Output
O-	Ground for the Analog Output
BZ	Block Discharge
AWV	Valve Output
a	Valve Control Output +
b	Valve Control Output 0 V
SY	Synchronization
SY-	Ground for the Synchronization
E+	Receiver-Line
S+	Emitter-Line
≡	Grounding
SnR	Switching Distance Reduction
Rx+/-	Ethernet Receive Path
Tx+/-	Ethernet Send Path
Bus	Interfaces-Bus A(+)/B(-)
La	Emitted Light disengageable
Mag	Magnet activation
RES	Input confirmation
EDM	Contactors Monitoring

ENARs422	Encoder A/Ā (TTL)
ENBRs422	Encoder B/B̄ (TTL)
ENA	Encoder A
ENB	Encoder B
AMIN	Digital output MIN
AMAX	Digital output MAX
OK	Digital output OK
SY In	Synchronization In
SY OUT	Synchronization OUT
OLT	Brightness output
M	Maintenance
rsv	reserved
Wire Colors according to IEC 60757	
BK	Black
BN	Brown
RD	Red
OG	Orange
YE	Yellow
GN	Green
BU	Blue
VT	Violet
GY	Grey
WH	White
PK	Pink
GNYE	Green/Yellow

5.3 Diagnosis

Causes triggering the contamination warning (flashing LED):

Display LED	Diagnosis/Cause	Elimination
Continuous flashing at approx. 2.5 Hz	Contamination	Carefully clean the optic cover with a cloth
	Aged emitter diode	Replace the sensor
	Unreliable working range	<ul style="list-style-type: none"> • Increase the sensor's switching distance • Reduce distance between sensor and object
Continuous flashing at approx. 5 Hz	Short circuit	Check electrical wiring and eliminate the short circuit
	Over-temperature	Disconnect the sensor from the supply voltage and allow it to cool
	Hardware error	Replace the sensor



NOTICE

Required action in case of fault:

1. Shut down the machine.
2. Analyze and eliminate the cause of error with the aid of the diagnostics information.
3. If the error cannot be eliminated, please contact wenglor's support department.
4. Do not operate in case of indeterminate malfunctioning.
5. The machine must be shut down if the error cannot be definitively explained or properly eliminated.



DANGER

Risk of personal injury or property damage in case of non-compliance!

The system's safety function is disabled. Personal injury and damage to equipment may occur.

→ Required action as specified in case of fault.

6 Settings

The sensor can be set via the control, IO-Link and wTeach2. The different setting options are outlined below.

6.1 Adjustment via Potentiometer

Control Panel



- Adjust and securely mount the sensor such that the spot strikes the object to be detected.
- Turn the potentiometer all the way to the left.
- Turn up the potentiometer until activation occurs and, if required, turn it up a bit further for increased switching reliability.

6.2 Setting via IO-Link and wTeach2

The sensors can exchange parameters and process data via IO-Link. The parameters can be used to make many additional settings on the device. The process data transmit cyclical data and condition monitoring.

To this end, the sensor is connected to a suitable IO-Link master (see product detail page/complementary products). The interface protocol and the IODD can be found at www.wenglor.com in the download area for the respective product.

For information on installing and connecting the wTeach2 software and its structure, as well as information on the general functions, see the wTeach2 operating instructions. They can be found online in the download area at www.wenglor.com under order number DNNF005.



NOTICE

When changing the mode of operation, a reset must then be carried out so that the changeover is carried out.

7 Function Description

7.1 Sensor Functions

Function	Possible settings	Default setting
mode of operation	There are two operating modes available. Standard Speed	Standard
Emitted light	The transmit LED of the sensor can be switched on or off. On Transmit LED on Off Transmit LED off The sensor no longer supplies a measured value. Note! <ul style="list-style-type: none"> If the emitted light LED is switched off, the sensor behavior corresponds to the status "No signal." 	On
Hysteresis	The hysteresis is the difference between the switch-on and switch-off point and can be set in 3 stages. Minimum Medium Maximum	Minimum



NOTICE

When changing the mode of operation, a reset must then be carried out so that the changeover is carried out.

7.2 Output Functions

The output functions are used to set the physical outputs.

Function	Possible settings	Default
PNP/NPN/push-pull	PNP The load or analysis module is connected between the negative pole (reference) and the output. When the sensor switches, the output is connected to the positive pole via an electronic switch. The switching signal is maintained when a pull-down resistor is connected. NPN The load or the analysis module is connected between the positive pole (reference) and the output. When the sensor switches, the output is connected to the negative pole via an electronic switch. The switching signal is maintained when a pull-up resistor is connected. push-pull PNP and NPN are switched alternately.	PNP
Normally closed/normally open	NO Light switching (normally open) The output is closed when the condition has been met, depending on the setting (switching point, warning, error).	A1: NO A2: NC

Function	Possible settings	Default
	NC Dark switching The output is open when the condition has been met, depending on the setting (switching point, warning, error).	
On-delay	0...10,000 ms	0 ms
Off-delay	0...10,000 ms	0 ms

7.3 Pin Function

The pin function is used to define the function of pins A1 and A2, as these can be used for different functions.

Function	Possible settings	Default
E/A2	Antivalent switching output The switching output switches antivalently to switching output A1. Error output The error output switches if one of the assigned errors occurs; see table Status messages.	Antivalent switching output

7.4 Switching Point Functions (SSC1)

The switching point functions are used to set the switching point. This is assigned to output A1.

Function	Possible settings	Default setting
switching point	The switching point corresponds to the switching threshold of the contrast value and is defined in digits. 0...255	255

8 IO-Link

The sensors can exchange parameters and process data via IO-Link. The parameters can be used to make many additional settings on the device. The process data transmit cyclical data and condition monitoring.

To this end, the sensor is connected to a suitable IO-Link master (see product detail page/complementary products). The interface protocol and the IODD can be found at www.wenglor.com in the download area for the respective product.

9 **wTeach2 Configuration Software**

For information on installing and connecting the wTeach2 software and its structure, as well as information on the general functions, see the wTeach2 operating instructions. They can be found online in the download area at www.wenglor.com under order number DNNF005.

10 Maintenance Instructions



NOTICE

This wenglor product is maintenance-free.

Cleaning and inspection of the plug connections at regular intervals are advisable.

Do not clean the product with solvents or cleaning agents that could damage the product.

The product must be protected against contamination during initial start-up.

11 Proper Disposal

wenglor sensoric GmbH does not accept the return of unusable or irreparable products. Respectively valid national waste disposal regulations apply to product disposal.

12 **Declarations of Conformity**

Declarations of conformity can be found on our website at www.wenglor.com in the product's separate download area.