

Fiber-optic amplifier

P1XD001

Part Number



- Can be adjusted using potentiometers
- Diverse usage options: Barrier, reflex, reflex light barrier
- IO-Link 1.1
- Tool-free assembly

Fiber-optic sensors work according to the energetic principle in which light is emitted via one fiber-optic cable and received via another. The amplifier can be adapted to a wide range of application requirements through the use of flexible plastic fiber-optic cables or glass fiber-optic cables with adapter no. 7. The switching point can be easily adjusted using the potentiometer. Both the fiber-optic cable and the sensor can be mounted without tools, which further simplifies handling.

Technical Data

Optical Data	
Switching Hysteresis	< 15 %
Light Source	Red Light
Service Life (T = +25 °C)	> 100000 h
Max. Ambient Light	10000 Lux
Electrical Data	
Supply Voltage	10...30 V DC
Supply Voltage with IO-Link	18...30 V DC
Current Consumption (U _b = 24 V)	< 30 mA
Switching Frequency	0,9 kHz
Switching frequency (speed mode)	1,8 kHz
Response Time	263 μs
On-/Off-Delay	0...200 ms
Temperature Drift	< 10 %
Temperature Range	-25...60 °C
Switching Output Voltage Drop	< 2 V
Switching Output/Switching Current	100 mA
Short Circuit Protection	yes
Reverse Polarity Protection	yes
Overload Protection	yes
IO-Link transmission speed	COM2
Interface	IO-Link V1.1
Protection Class	III
Mechanical Data	
Setting Method	Potentiometer
Housing Material	Plastic, ABS
Housing Material	Plastic, PA
Housing Material	Plastic, PC
Degree of Protection	IP50
Connection	M8 × 1; 4-pin
DIN-Rail mounting	35 mm
Safety-relevant Data	
MTTFd (EN ISO 13849-1)	640,47 a
IO-Link	●
PNP NC, PNP NO	●
Connection Diagram No.	215
Control Panel No.	P17
Suitable Connection Equipment No.	7

Complementary Products

IO-Link Master
Plastic Fiber-Optic Cable

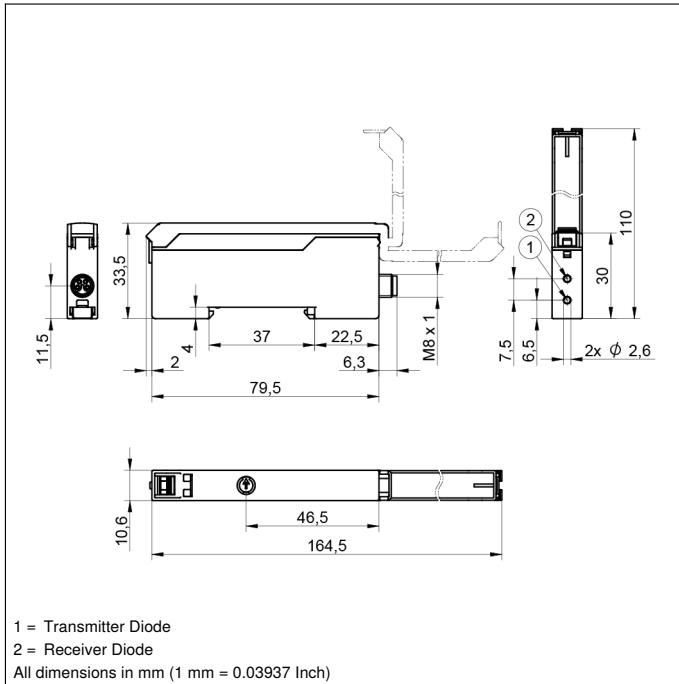

Ctrl. Panel

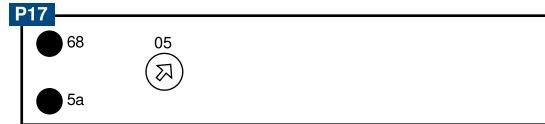

05 = Switching Distance Adjuster
 5a = Switching Status Indicator, A1
 68 = Power LED

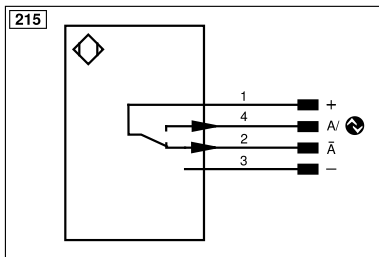

Legend					
+	Supply Voltage +	nc	Not connected	ENBRS422	Encoder B/B̄ (TTL)
-	Supply Voltage 0 V	U	Test Input	ENA	Encoder A
~	Supply Voltage (AC Voltage)	Ū	Test Input inverted	ENb	Encoder B
A	Switching Output (NO)	W	Trigger Input	AMIN	Digital output MIN
Ā	Switching Output (NC)	W-	Ground for the Trigger Input	AMAX	Digital output MAX
V	Contamination/Error Output (NO)	O	Analog Output	AOK	Digital output OK
ȳ	Contamination/Error Output (NC)	O-	Ground for the Analog Output	SY In	Synchronization In
E	Input (analog or digital)	BZ	Block Discharge	SY OUT	Synchronization OUT
T	Teach Input	Amv	Valve Output	OLT	Brightness output
Z	Time Delay (activation)	a	Valve Control Output +	M	Maintenance
S	Shielding	b	Valve Control Output 0 V	rsv	Reserved
RxD	Interface Receive Path	SY	Synchronization	Wire Colors according to DIN IEC 60757	
TxD	Interface Send Path	SY-	Ground for the Synchronization	BK	Black
RDY	Ready	E+	Receiver-Line	BN	Brown
GND	Ground	S+	Emitter-Line	RD	Red
CL	Clock	±	Grounding	OG	Orange
E/A	Output/Input programmable	SnR	Switching Distance Reduction	YE	Yellow
⚡	IO-Link	Rx+/-	Ethernet Receive Path	GN	Green
PoE	Power over Ethernet	Tx+/-	Ethernet Send Path	BU	Blue
IN	Safety Input	Bus	Interfaces-Bus A(+)/B(-)	VT	Violet
OSSD	Safety Output	La	Emitted Light disengageable	GY	Grey
Signal	Signal Output	Mag	Magnet activation	WH	White
BI_D+/-	Ethernet Gigabit bidirect. data line (A-D)	RES	Input confirmation	PK	Pink
ENo RS422	Encoder 0-pulse 0/0̄ (TTL)	EDM	Contact Monitoring	GNYE	Green/Yellow
PT	Platinum measuring resistor	ENARS422	Encoder A/Ā (TTL)		

