

Mounting Console

for \varnothing 16...17.8 mm (OHII/OKI/U2GT)

Z16M001

Part Number



Technical Data

Mechanical Data

Mounting type, device-side	Bayonet fastening
Mounting type, system-side	Mounting bracket
Mounting type, system-side	Mounting in through-hole
Material	Silicone (FDA)
Material	Stainless steel, V4A (1.4404 / 316L)
Degree of Protection	IP68
Degree of Protection	IP69K
Scope of delivery	1 × mounting console
Packaging unit	1 Piece
Use	for round housing
Hygienic Design	<input checked="" type="checkbox"/>
Detergent resistant	<input checked="" type="checkbox"/>

- For holes from > 24 mm to < 35 mm
- Hygienic design makes it easy to clean
- Made with food safe materials that are FDA approved
- Resistant to cleaning agents
- Seamless integration of hygiene sensor directly into mounting console
- Self-centering in M30 bore, thanks to integrated step in the threaded sleeve

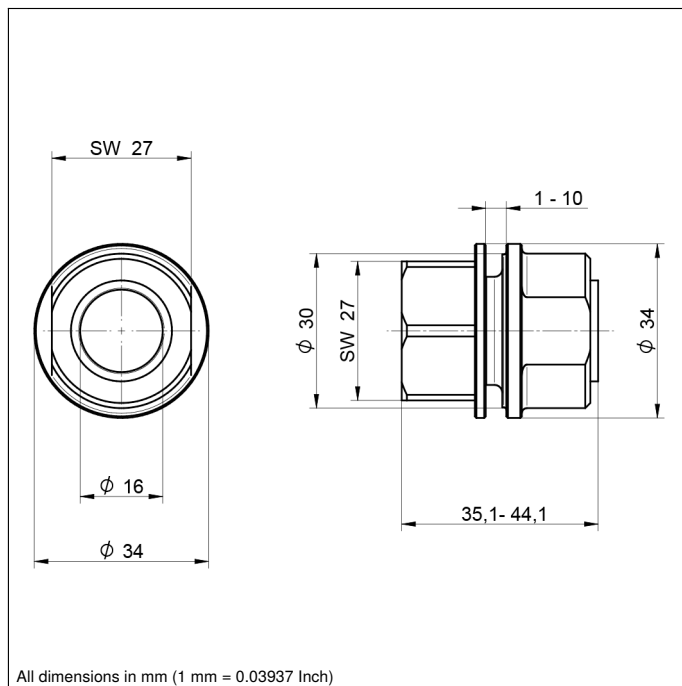

This complete system, which integrates seamlessly into the machine, includes numerous other components as well as the mounting console. The hygiene sensors and mounting tubes can be fed through the system's side panel with the aid of the mounting console and fastened there without any gaps.

