



# LRLx200

## OPERATING INSTRUCTIONS

wenglor TPL

### PREAMBLE

This Technical User Guide contains warnings and guidance for correct and safe operation of the product. These instructions must be followed at all times. wenglorTPL will not be held responsible for problems caused by using the product contrary to these instructions and the Warranty will be deemed invalid.



### UNPACKING

This product is packed at the factory using suitable materials for safe transport. To open the package, do not use any cutting blade to avoid damaging the product(s). Please use the delivered accessories if needed. (Do not use any other products or equivalents to replace the delivered accessories).

In the event of damage occurring during shipping, it must be reported to the carrier at time of delivery (including noting the damage in writing on the delivery documents). It is also your responsibility to notify wenglorTPL in writing of the damage within 24 hours of receipt of the package. If these instructions are not followed, wenglorTPL reserves the right not to accept requests for return and exchange of damaged products.

### RISK CLASS

The applicable Standard EN-62471 classifies LED Lighting into 4 classes according to their degree of hazard severity. The table below summarises the risks associated with our standard products.

Colour	Class	Risk
Red 630 nm	0	none
White WHI, IR 850 nm	1	low

wenglorTPL can provide **guidance notes to minimise photo-biological risks**, including the nominal minimum operating distance. Please contact wenglorTPL through your **usual representative** for this information.

In all cases, wenglorTPL recommends the use of **the protection glasses**.



# LRLx200

## OPERATING INSTRUCTIONS

P2/8

### ■ DIMENSIONS

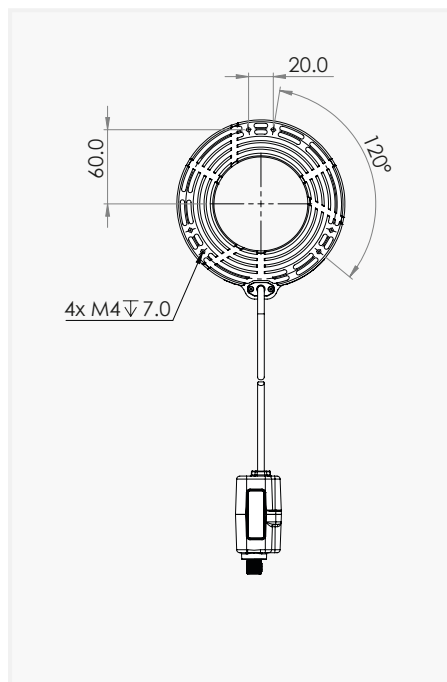
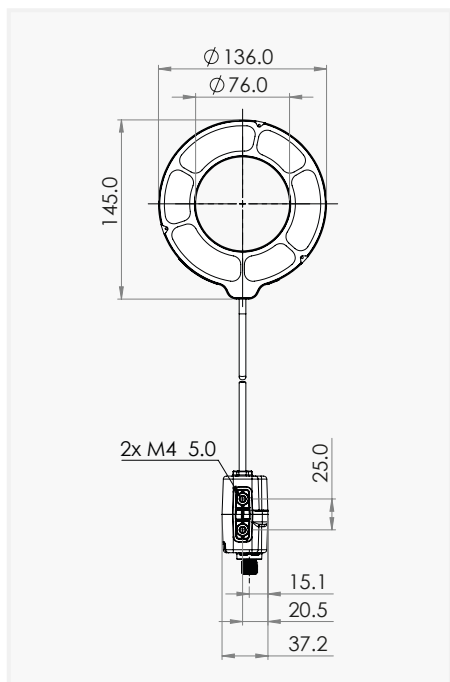

	External Ø (mm)	Internal Ø (mm)	Thickness (mm)
<b>LRLx200</b>	136	76	28.7

	Length (mm)	Width (mm)	Thickness (mm)
<b>Power supply</b>	83.3	37.2	42.7

### ■ LED INDICATORS

The power supply is equipped with 2 LED indicators :

- **N°1:** indicates that the light is powered but the LEDs are not turned ON with this indicator alone.
- **N°2:** indicates that the LEDs are switched on.

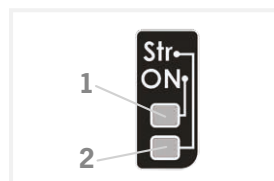



## ANGLE CHANGER FIXING

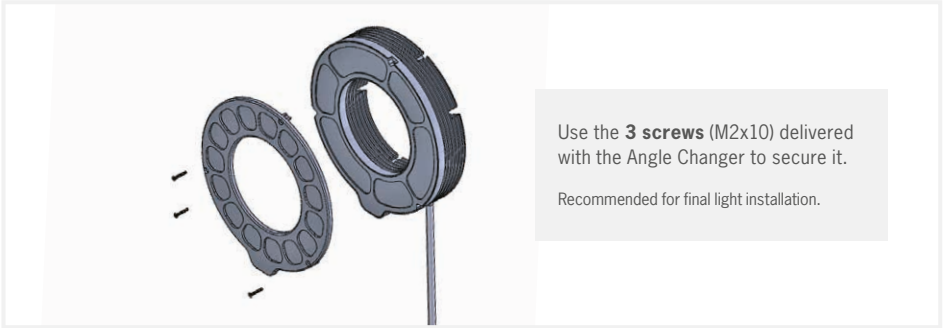

## CONNECTION

### M12 Connector 5 male points

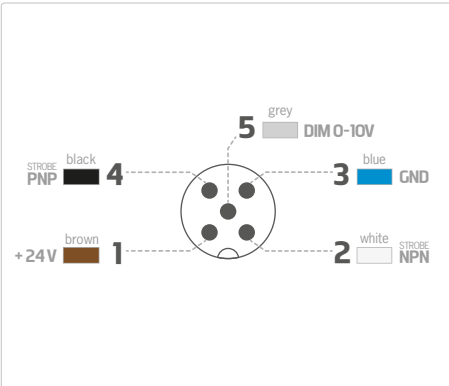

#### STROBE PNP :

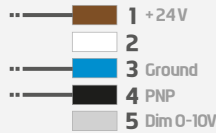

#### STROBE NPN :

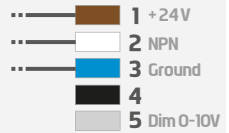

#### CONTINUOUS MODE :

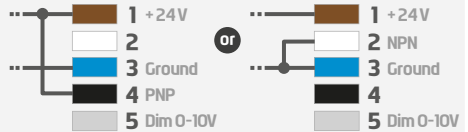

**EMC IMMUNITY CONNECTIONS:** for greater EMC immunity when using the light under Strobe operation, configure the signal connections as illustrated here. For Dimming, the Pin (5) should be connected to a voltage between 0V and 10V to ensure light output is correctly configured.



#### STROBE PNP :

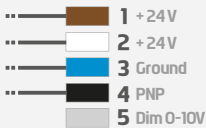

#### STROBE NPN :

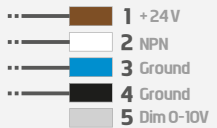



# LRLx200

## OPERATING INSTRUCTIONS

P4/8

### CONTROL

The product is optimised for a lifespan >50kh in a 40°C (104°F) atmosphere.  
In strobe mode, the strobing time is directly equivalent to the time during which the strobe entry is activated.

#### STROBE PNP & NPN:

- **PNP** : from 5 to 24V for 100% ON. From 0 to 1V for 100% OFF.
- **NPN** : less than 1V for 100% ON. Above 2V for 100% OFF. Max 20V.

Brightness	D max	t max	f max
30% to 100%	N/A	CW	N/A
100% to 300%	10%	10 ms	750Hz

CW : Continuous Working  
D : Duty Cycle  
t : pulse duration  
f : frequency

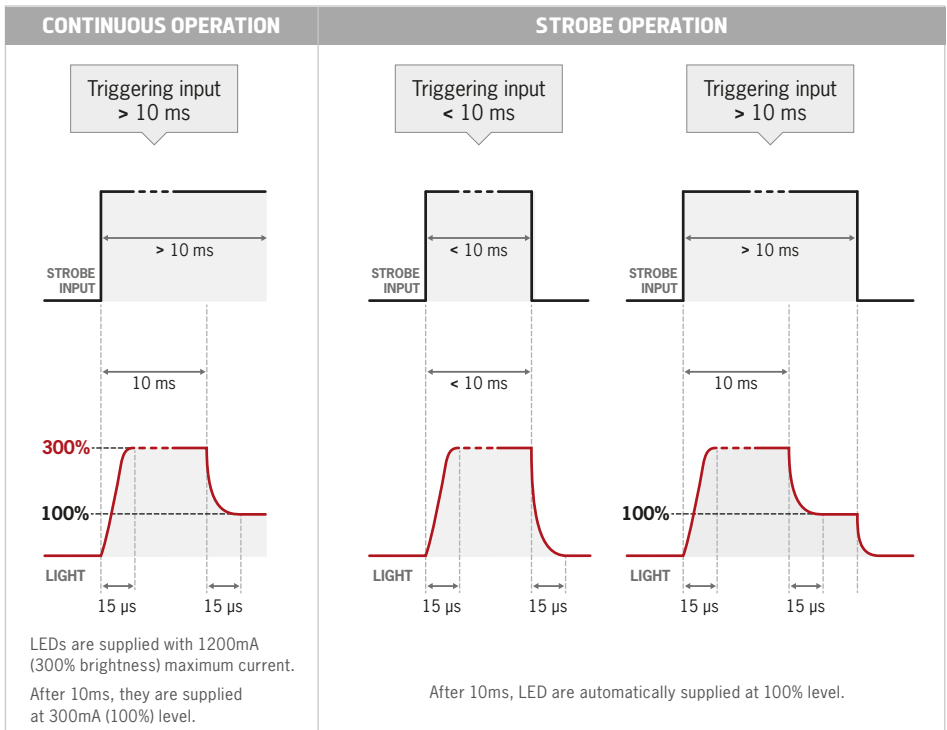



## ■ DIMMING 0-10V ON PIN 5

PLEASE DO NOT EXCEED THE 0-10V DIMMING RANGE  
DO NOT CONNECT PIN 5 DIRECTLY TO 24VDC 

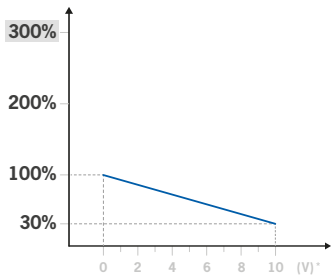

### CONTINUOUS WORKING

Dimming during continuous working (CW) operation

\* Voltage applied to PIN 5.

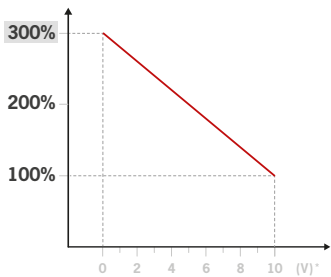

### STROBE OVERDRIVE ≤10ms ON TIME

Dimming during strobe mode  
≤10ms maximum on time

\* Voltage applied to PIN 5.

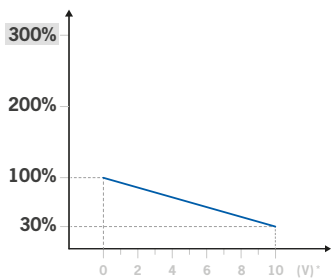

### STROBE >10ms ON TIME

Dimming during strobe mode after LEDs are ON for more than 10ms

\* Voltage applied to PIN 5.



# LRLx200

## OPERATING INSTRUCTIONS

P6/8

### POWER SUPPLY

	LRLx200
Consumption CW mode	0.9A
Consumption Strobe mode*	3.6A
Min. functioning Voltage	20V in the light input
Normal functioning Voltage	24V in the light input ( $\pm 10\%$ )
Max. functioning Voltage	30V in the light input
Max. consumption Strobe and Dimming signal	10mA

\*Strobed with 10% duty cycle – this is the peak consumption. You must use a power supply with this rating.

### USER SAFETY

**Do not modify or dismantle all or part of the product.**

**Respect the power supply voltages and the connection terminals.**

**Ensure power supply is switched off whilst connecting product and turn on only once product is fully connected. Failure to do this may damage the product and invalidate the Warranty**

**Do not stare at the lighting source directly.**

**Follow advice below for installation to minimise operator exposure to the light source.**



### INSTALLATION GUIDANCE:

- Forbid or limit the direct access to the lighting source (exposure into the radiation axis).
- Establish a security perimeter to prevent the operators from approaching the lighting source beyond the recommendations of the manufacturer.
- If the workstation permits it, introduce a filter that will stop the lighting radiation under a fixed or adjustable frame between the source and the operator. When these measures cannot be implemented, supply the operators with glasses.

It is the responsibility of the persons installing this product to ensure that all means possible (such as those stated above) have been implemented to reduce exposure of the machine operators to the light emitted from this product.



High ambient temperatures and insufficient heat dissipation can lead to hot housing surfaces. Do not touch the light during operation. Keep a minimum distance of 20 mm between the light and thermally insulating surfaces or mount the light on a thermally conductive surface.



## ■ PRODUCT LIFETIME

LED lifetime can typically be increased using strobe mode where possible. Strobing the light or turning the illumination on and off (using PNP or NPN lines) allows less temperature build up at the LED junction. The junction temperature of the LED is directly correlated with the lifetime of the LED chip. Maximum ambient air temperature = maximum 40°C/104°F.

LEDs naturally lose some intensity over time because of heat. Using the dimming and setting a reference brightness is a method for keeping the brightness level constant over a very long time, especially on brightness critical applications. wenglorTPL products have been integrated in factories since 2006, many of which are still in operation today. LED lifetime and heat management are at the forefront of our design considerations.

## ■ EQUIPMENT MAINTENANCE

### CLEANING (when the product is switched off)

Please use a soft and dry cloth. Do not use any abrasive material.  
Do not use any cleaning solvent or aggressive chemical product.  
wenglorTPL recommends to use isopropyl alcohol.

## ■ OPERATING CONDITIONS

-10° to +40°C (14° to +104°F) / 80% of humidity without condensation.  
No thermal shock (max temperature variation: 10°C (18°F) in 24h).  
Not for outdoor use.

**wenglor**TPL

wenglor Straße 3  
88069 Tettnang  
Germany

+49 (0)7542 5399 800

support@wenglor.com



www.wenglor.com