

Machine Vision Camera

BBVK002

Part Number



- Compact and robust housing in 29 × 64.4 × 29 mm format
- Different lenses can be adapted thanks to standard thread
- Flexible mounting options from 4 sides
- Image chip with Global Shutter for dynamic applications

Machine Vision Cameras make it possible to record images in vision applications. The images are read out via a 1-gigabit Ethernet interface. The camera can be connected via a PoE port so that only one cable is required. The small and rugged housing and the C mount threaded connection can be easily and flexibly integrated. State-of-the-art CMOS sensor technology ensures high resolution and optimum image quality without noise even in difficult lighting conditions.

Technical Data

Optical Data	
Resolution	1440 × 1080 Pixel
Resolution	1,6 MP
Pixel Size	3,45 × 3,45 μm
Sensor Type	CMOS
Sensor Designation	Sony IMX273
Image Chip	color
Image chip size	1/2,9"
Frame rate (fullframe)	< 71,6 fps
Electrical Data	
Supply Voltage	12...24 V DC
Current Consumption (Ub = 24 V)	< 130 mA
Temperature Range	-20...55 °C
Storage temperature	-30...60 °C
Atmospheric humidity	20...95 %
Number of GPIOs (general purpose I/Os)	2
Number of Flash Outputs	1
Flash Output	Optoisolator
Number of trigger inputs	1
Trigger Input	Optoisolator
Supported PoE Standard	IEEE802.3af
Mechanical Data	
Lens thread	C-Mount
Housing Material	Aluminum, powder-coated
Optic Cover	Glass
Degree of Protection	IP67
Connection	M8 × 1; 8-pin
Type of Connection Ethernet	M12 × 1; 8-pin, X-cod.
Function	
Global Shutter	yes
PoE	yes

Complementary Products

EHSS001 Switch
Illumination Technology
Lens
Machine Vision Controller MVC
Software
ZBVG protective tube

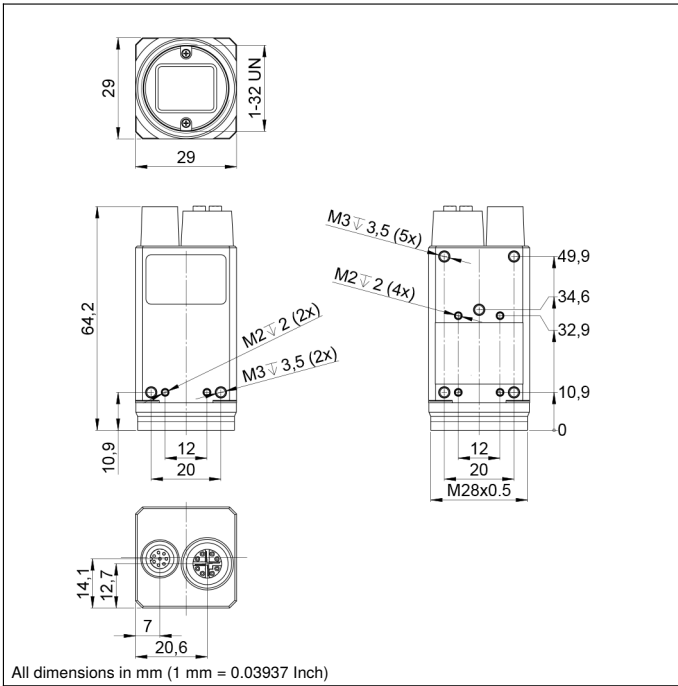

All dimensions in mm (1 mm = 0.03937 Inch)

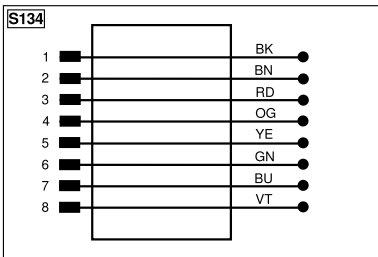
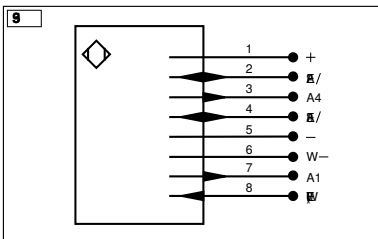

Legend			
+	Supply Voltage +	PT	Platinum measuring resistor
-	Supply Voltage 0 V	nc	Not connected
~	Supply Voltage (AC Voltage)	U	Test Input
A	Switching Output (NO)	Ū	Test Input inverted
Ā	Switching Output (NC)	W	Trigger Input
V	Contamination/Error Output (NO)	W-	Ground for the Trigger Input
Ṽ	Contamination/Error Output (NC)	O	Analog Output
E	Input (analog or digital)	O-	Ground for the Analog Output
T	Teach Input	BZ	Block Discharge
R	Reset input	Amv	Valve Output
Z	Time Delay (activation)	a	Valve Control Output +
S	Shielding	b	Valve Control Output 0 V
RxD	Interface Receive Path	SY	Synchronization
TxD	Interface Send Path	SY-	Ground for the Synchronization
RDY	Ready	E+	Receiver-Line
GND	Ground	S+	Emitter-Line
CL	Clock	⊕	Grounding
E/A	Output/Input programmable	SnR	Switching Distance Reduction
IO-Link		Rx+/-	Ethernet Receive Path
PoE	Power over Ethernet	Tx+/-	Ethernet Send Path
IN	Safety Input	Bus	Interfaces-Bus A(+)/B(-)
OSSD	Safety Output	La	Emitted Light disengageable
Signal	Signal Output	Mag	Magnet activation
BI_D+/-	Ethernet Gigabit bidirect. data line (A-D)	RES	Input confirmation
ENo RS422	Encoder 0-pulse 0/0 (TTL)	EDM	Contactor Monitoring
			ENARs422 Encoder A/Ā (TTL)
			ENBRs422 Encoder B/B̄ (TTL)
			ENA Encoder A
			ENB Encoder B
			AMIN Digital output MIN
			AMAX Digital output MAX
			AOK Digital output OK
			SY In Synchronization In
			SY OUT Synchronization OUT
			OLT Brightness output
			M Maintenance
			rsv Reserved
			Wire Colors according to DIN IEC 60757
			BK Black
			BN Brown
			RD Red
			OG Orange
			YE Yellow
			GN Green
			BU Blue
			VT Violet
			GY Grey
			WH White
			PK Pink
			GNYE Green/Yellow

Connection options

for L series illumination

