

Ring Light

infrared, 37 mm

LRL100

Part Number



- Auto strobe (overdrive) light with robust housing & integrated current control
- Compact and powerful, designed for easy installation
- Flexibility: expand the beam angle with an Angle Changer
- IP67-certified LED ring light

wenglor LRLx100 ring lights are compact and bright ring lights with two operating modes: Continuous mode and strobe overdrive. The robust IP67 housing is equipped with magnets and fixing points for mounting angle changers, providing unparalleled flexibility in ring light illumination.

Technical Data

Optical Data	
Light Source	Infrared Light
Wavelength	850 nm
Beam angle	± 5 °
Infrared light output	677,2 W/m ²
Measuring point distance	200 mm
Compatible with	Angle Changer
Environmental conditions	
Temperature Range	-10...40 °C
Storage temperature	-20...60 °C
Atmospheric humidity	< 80%, non-condensing
Electrical Data	
Supply Voltage	21,6...26,4 V DC
Power	15,4 W
Peak power	63,36 W
Current Consumption Continuous Mode (U _b = 24 V)	0,66 A
Current consumption flash mode overdrive (operating voltage = 24 V)	2,64 A
Flash Duration (max.)	10 ms
Duty Cycle (max.)	< 0,1
Rise time	15 μs
Fall time	15 μs
Input signal	PNP/NPN
Short Circuit Protection	yes
Reverse Polarity Protection	yes
Overload Protection	yes
Protection Class	III
Dimming	0...10 V ± 100...30%
Overdrive	yes
Mechanical Data	
Luminous Field	Ø 86 mm
Housing Material	Aluminum, anodised
Housing Material	Plastic, PMMA
Degree of Protection	IP67
Connection	M12 × 1; 5-pin
Max. cable length	10 m
Function	
Operating modes	Continuous, Strobe Overdrive

Complementary Products

Connection cables
Mounting adapter
ZRLG angle changer

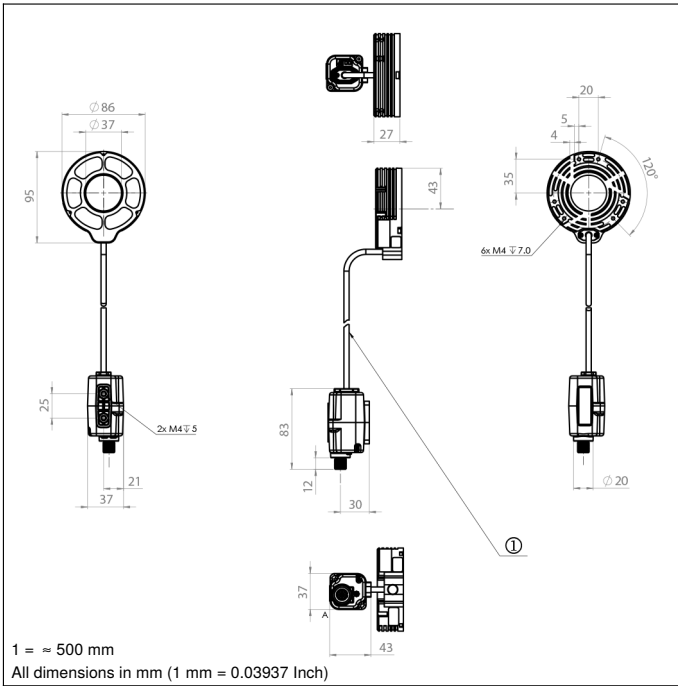
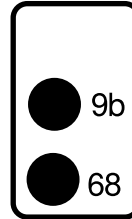
Ctrl. Panel
T21

68 = supply voltage indicator
 9b = Strobe Mode Indicator



Legend			
+	Supply Voltage +	nc	Not connected
-	Supply Voltage 0 V	U	Test Input
~	Supply Voltage (AC Voltage)	Ü	Test Input inverted
A	Switching Output (NO)	W	Trigger Input
Ā	Switching Output (NC)	W-	Ground for the Trigger Input
V	Contamination/Error Output (NO)	O	Analog Output
ȳ	Contamination/Error Output (NC)	O-	Ground for the Analog Output
E	Input (analog or digital)	BZ	Block Discharge
T	Teach Input	Amv	Valve Output
Z	Time Delay (activation)	a	Valve Control Output +
S	Shielding	b	Valve Control Output 0 V
RxD	Interface Receive Path	SY	Synchronization
TxD	Interface Send Path	SY-	Ground for the Synchronization
RDY	Ready	E+	Receiver-Line
GND	Ground	S+	Emitter-Line
CL	Clock	±	Grounding
E/A	Output/Input programmable	SnR	Switching Distance Reduction
IO-Link		Rx+/-	Ethernet Receive Path
PoE	Power over Ethernet	Tx+/-	Ethernet Send Path
IN	Safety Input	Bus	Interfaces-Bus A(+)/B(-)
OSSD	Safety Output	La	Emitted Light disengageable
Signal	Signal Output	Mag	Magnet activation
BI_D+/-	Ethernet Gigabit bidirect. data line (A-D)	RES	Input confirmation
ENo RS422	Encoder 0-pulse 0/0 (TTL)	EDM	Contactor Monitoring
PT	Platinum measuring resistor	ENARs422	Encoder A/Ā (TTL)
			Encoder B/B̄ (TTL)
			Encoder A
			Encoder B
			Digital output MIN
			Digital output MAX
			Digital output OK
			Synchronization In
			Synchronization OUT
			Brightness output
			Maintenance
			Reserved
			Wire Colors according to DIN IEC 60757
			BK Black
			BN Brown
			RD Red
			OG Orange
			YE Yellow
			GN Green
			BU Blue
			VT Violet
			GY Grey
			WH White
			PK Pink
			GNYE Green/Yellow

