

Operating Instructions

PNBC108

Laser Distance Sensor Triangulation



EN



Table of Contents

1	General	5
1.1	Information Concerning these Instructions	5
1.2	Explanation of Symbols	5
1.3	Limitation of Liability	6
1.4	Copyrights	6
2	For Your Safety	7
2.1	Use for Intended Purpose	7
2.2	Use for Other than the Intended Purpose	7
2.3	Personnel Qualifications	7
2.4	Modification of Products	8
2.5	General Safety Precautions	8
2.6	Laser Warnings	8
2.7	Approvals and Protection Class	9
3	Technical Data	10
3.1	General Data	10
3.2	Default Settings	11
3.3	Surface Effects	11
3.4	Housing Dimensions	12
3.5	Layout	12
3.6	Control Panel	13
3.7	Complementary Products	13
3.8	Scope of delivery	13
4	Transport and Storage	14
4.1	Transport	14
4.2	Storage	14
5	Installation and Electrical Connection	15
5.1	Installation	15
5.2	Electrical Connection	15
5.3	Troubleshooting	16
6	Function Description	18
6.1	Network Settings	18
6.2	Exposure Control	19
6.3	Evaluation Method	21
6.3.1	Center of Gravity (FCOG)	22
6.3.2	MEDIAN	22
6.3.3	FCOG Filter	22
6.3.4	Flanks (Edge)	22
6.4	Input/Output Functions (E/A)	23
6.4.1	Pin Functions	23
6.4.2	Output Functions	23
6.4.3	Input Functions	24
6.5	Switching Point Functions	24
6.6	Encoder Input	25
6.7	Analog Output	27
6.8	Condition Monitoring Functions	27

6.9	Digital Read-Out of Measured Values	27
6.9.1	Distance Measurement with Encoder Output Filter	29
6.9.2	Distance Measurement with Single-Channel Trigger	29
6.10	Measuring Accuracy and Error Influence.....	30
6.10.1	Calibration Report.....	30
6.10.2	Surface Structure and Condition of the Object to Be Measured	31
6.10.3	Ambient Light.....	32
7	Settings via Website.....	33
7.1	Accessing the Website	33
7.2	Network Settings.....	34
7.3	Basic Adjustment Parameters	34
7.4	Input/Output Functions.....	35
8	wTeach2 Configuration Software.....	37
8.1	wTeach2 Functions	37
9	Interface Protocol Ethernet TCP/IP.....	38
9.1	General Measuring Commands.....	38
9.1.1	Selecting the “Continuous Distance Measurement” Data Format.....	38
9.1.2	Selecting the “Extended Continuous Measurement” Data Format	38
9.1.3	Stop Measurement.....	38
9.1.4	Selecting the Data Format for Peak Data.....	38
9.1.5	Package Length	39
9.1.6	Fast Retransmissions	39
9.1.7	Reply Mode	39
9.2	Device Specific Information	39
9.2.1	Querying the Order Number	39
9.2.2	Querying the Product Version	39
9.2.3	Querying the Manufacturer.....	39
9.2.4	Querying the Description.....	40
9.2.5	Querying the Serial Number	40
9.2.6	Querying the MAC Address	40
9.2.7	Querying the Hardware Version.....	40
9.3	Network Settings.....	40
9.3.1	IP Address.....	40
9.3.2	Gateway Address.....	40
9.3.3	Reset Network Settings to Default Values	40
9.4	Measured Value Settings	41
9.4.1	Evaluation Method	41
9.4.2	Average Filter.....	41
9.4.3	Measuring Rate	41
9.4.4	Output Rate.....	41
9.4.5	Output Filter.....	42
9.4.6	Downsampling Parameters.....	42
9.4.7	Exposure Mode	42
9.4.8	Control of Laser Power and Exposure Time.....	42
9.4.9	Switch Laser On/Off	43
9.4.10	Fixed Laser Power	43
9.4.11	Maximum Laser Power	43
9.4.12	Current Laser Power.....	43
9.4.13	Fixed Exposure Time.....	44
9.4.14	Maximum Exposure Time.....	44
9.4.15	Current Exposure Time	44
9.4.16	Offset	44
9.4.17	Protective Screen Compensation	44
9.4.18	Encoder Reset.....	45
9.4.19	Encoder Counter Right Shift	45
9.4.20	Reset to Default Values	45
9.5	I/O Settings.....	45
9.5.1	Analog Mode	45
9.5.2	Querying Input Status.....	45

9.5.3	Querying the Input/Output Status of All Inputs/Outputs.....	45
9.5.4	Pin Function	46
9.5.5	Output.....	46
9.5.6	Output Function.....	46
9.5.7	Teach-In Mode	47
9.5.8	Teaching In the Switching Distance	47
9.5.9	Window Size.....	47
9.5.10	Changing the Switching Point.....	48
9.5.11	Switching Hysteresis.....	48
9.5.12	Switching Reserve	48
9.5.13	Input Load.....	49
9.5.14	Input Function	49
9.5.15	Minimum Intensity	49
9.6	Header and Data Format	49
9.6.1	Continuous Distance Measurement	50
9.6.2	Extended Continuous Measurement (Distance, Intensity, Encoder)	51
9.6.3	Peak Data	52
9.6.4	Description of the Measurement Data	53
10	Interface Protocol EtherCAT	55
11	Maintenance Instructions	70
12	Proper Disposal	71
13	Declarations of Conformity.....	72

1 General

Valid for sensors with firmware V5.3.3 or higher.

1.1 Information Concerning these Instructions

- These instructions make it possible to use the product safely and efficiently.
- These instructions are an integral part of the product and must be kept on hand for the entire duration of its service life.
- Local accident prevention regulations and national work safety regulations must be complied with as well.
- The product is subject to further technical development, and thus the information contained in these operating instructions may also be subject to change. The current version can be found at www.wenglor.com in the product's separate download area.



INFORMATION

The operating instructions must be read carefully before using the product and must be kept on hand for later reference.

1.2 Explanation of Symbols

- Safety precautions and warnings are emphasized by means of symbols and signal words.
- Safe use of the product is only possible if these safety precautions and warnings are adhered to.

The safety precautions and warnings are laid out in accordance with the following principle:

SIGNAL WORD

Type and source of danger!

Possible consequences in the event that the hazard is disregarded.

→ Measures for averting the hazard.

The meanings of the signal words, as well as the scope of the associated hazards, are listed below:



DANGER

This signal word indicates a hazard with a high degree of risk which, if not avoided, results in death or severe injury.



WARNING

This signal word indicates a hazard with a medium degree of risk which, if not avoided, may result in death or severe injury.



CAUTION

This signal word indicates a hazard with a low degree of risk which, if not avoided, may result in minor or moderate injury.



NOTICE

This signal word draws attention to a potentially hazardous situation which, if not avoided, may result in property damage.



INFORMATION

Information draws attention to useful tips and suggestions, as well as information on efficient, error-free use.

1.3 Limitation of Liability

- The product has been developed in consideration of the current state-of-the-art technology, as well as applicable standards and guidelines. Subject to change without notice.
- A valid declaration of conformity can be accessed at www.wenglor.com in the product's separate download area.
- wenglor sensoric elektronische Geräte GmbH (hereinafter referred to as "wenglor") excludes all liability in the event of:
 - Non-compliance with the instructions
 - Use of the product for purposes other than those intended.
 - Use by untrained personnel.
 - Use of unapproved spare parts.
 - Unapproved modification of products.
- These operating instructions do not include any guarantees from wenglor with regard to the described procedures or specific product characteristics.
- wenglor assumes no liability for printing errors or other inaccuracies contained in these operating instructions unless wenglor was verifiably aware of such errors at the point in time at which the operating instructions were prepared.

1.4 Copyrights

- The contents of these instructions are protected by copyright law.
- All rights are reserved by wenglor.
- Commercial reproduction or any other commercial use of the provided content and information, in particular graphics and images, is not permitted without previous written consent from wenglor.

2 For Your Safety

2.1 Use for Intended Purpose

High-Precision Laser Distance Sensor

This product group includes high-performance sensors for measuring distance, which function in accordance with various principles in scanning mode operation. High-Precision Laser Distance Sensors are especially fast or accurate, or have large working ranges. They're extremely well suited for demanding applications. Even black and glossy objects can be reliably detected. Ethernet technology is integrated into selected sensors.

This product can be used in the following industry sectors:

- Special-purpose mechanical engineering
- Heavy mechanical engineering
- Logistics
- Automotive industry
- Food industry
- Packaging industry
- Pharmaceuticals industry
- Plastics industry
- Woodworking industry
- Consumer goods industry
- Paper industry
- Electronics industry
- Glass industry
- Steel industry
- Aviation industry
- Chemicals industry
- Alternative energies
- Raw materials extraction

2.2 Use for Other than the Intended Purpose

- Not a safety component in accordance with 2006/42/EC (Machinery Directive).
- The product is not suitable for use in potentially explosive atmospheres.
- The product may be used only with accessories supplied or approved by wenglor, or in combination with approved products. A list of approved accessories and combination products can be found at www.wenglor.com on the product detail page.



DANGER

Risk of personal injury or property damage in case of use for other than the intended purpose!

Use for other than the intended purpose may lead to hazardous situations.

→ Observe instructions regarding use for intended purpose.

2.3 Personnel Qualifications

- Suitable technical training is a prerequisite.
- In-house electronics training is required.
- Trained personnel who use the product must have (permanent) access to the operating instructions.



DANGER

Risk of personal injury or property damage in case of incorrect initial start-up and maintenance!

Personal injury and damage to equipment may occur.

→ Adequate training and qualification of personnel

2.4 Modification of Products



DANGER

Risk of personal injury or property damage if the product is modified!

Personal injury and damage to equipment may occur. Noncompliance may result in loss of the CE and/or UKCA mark and voiding of the warranty.

→ Modification of the product is not permitted

2.5 General Safety Precautions



INFORMATION

These instructions are an integral part of the product and must be kept on hand for the entire duration of its service life.

In the event of possible changes, the current version of the operating instructions can be found at www.wenglor.com in the product's separate download area.

Read the operating instructions carefully before using the product.

Protect the sensor against contamination and mechanical influences.

2.6 Laser Warnings

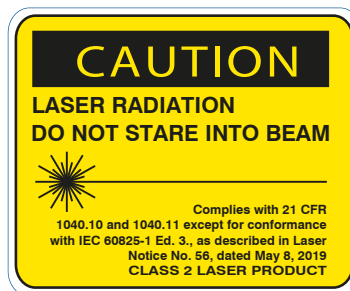
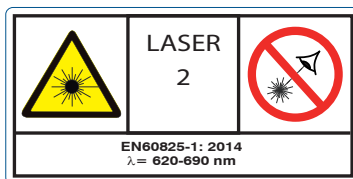

Laser Class 2 (EN 60825-1)

Applicable standards and safety regulations must be observed. The accompanying laser warnings must be attached. Do not look into the laser beam.



CAUTION

Use of control and/or adjusting devices other than those specified here, as well as the execution of other procedures, may result in hazardous exposure to laser radiation.

2.7 Approvals and Protection Class

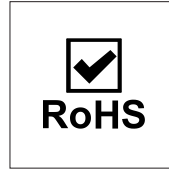
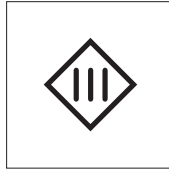
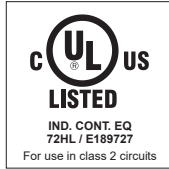

3 Technical Data

3.1 General Data

Technical Data	
Working Range	200...1000 mm
Measuring Range	800 mm
Linearity Deviation	375 µm
Reproducibility maximum	100 µm
Reproducibility: 1 Sigma	15 µm
Light Source	Laser (red)
Wavelength	658 nm
Service Life (T = +25 °C)	100000 h
Laser Class (EN 60825-1)	2
Max. Ambient Light	10000 Lux
Light Spot Diameter	< 1.6 mm
Electrical Characteristics	
Supply Voltage	15 ... 30 V DC
Current Consumption (U _b = 24 V)	280 mA
Switching Frequency	15 kHz
Response Time	< 33 µs
Output rate	1 ... 30000 /s
Temperaturdrift*	37.5 µm/K
Temperature Range	-10 ... 40 °C
Number of Switching Outputs	4
Switching Output Voltage Drop	< 1.5 V
Switching Output/Switching Current	100 mA
Schalteingang Low Pegel	< 2V
Schalteingang High Pegel	> 2,5 V
Schalteingang Eingangsimpedanz **	> 24kΩ
Switchable to NC/NO	NC/NO
Configurable as PNP/NPN/Push-Pull	yes
Analog output	Analog Output
Short Circuit Protection	yes
Reverse Polarity Protection	yes
Overload Protection	yes
Teach Mode	VT, FT
Interface	Ethernet TCP/IP; EtherCat
Baud Rate	100 Mbit/s
Protection Class	III
Web server	yes
Mechanical Characteristics	
Setting Method	Teach-In
Housing Material	Aluminum, anodised
Degree of Protection	IP67
Connection	M12 × 1; 8-pin
Type of Connection Ethernet	M12 × 1; 4-pin, D-cod.
Optic Cover	Glass

* with a sensor temperature of 20...40 °C

** only valid if input load switched off

3.2 Default Settings

Description	Default value
IP address	192.168.0.225
Subnet mask	255.255.0.0
Evaluation method	FCOG
Average filter	0 (corresponds to the off state)
Measuring rate	Auto
Laser	Auto
Offset	0.0 mm
Analog mode	4...20 mA
O1	Ext. teach-in: O3
E2 Hex Nut	Ext. teach-in: O4
A3 Hex Nut	Switching output: PNP / NO
A4 Hex Nut	Switching output: PNP / NO
Input load: 2 mA	On
Input	Operating voltage active
Teach-In mode	Foreground Teach-In

3.3 Surface Effects

The exposure time/measuring rate of the sensor depends on the nature of the object to be measured and the angle of impact. The following table shows the measuring rate for diffusely reflective objects of different reflectivities.

Object color	Reflectivity	Measuring rate
White	90%	30 kHz
Gray	20%	30 kHz
Black	6%	30 kHz

Values measured with Zenith Polymer diffuser with transmitting beam perpendicular to surface.

3.4 Housing Dimensions

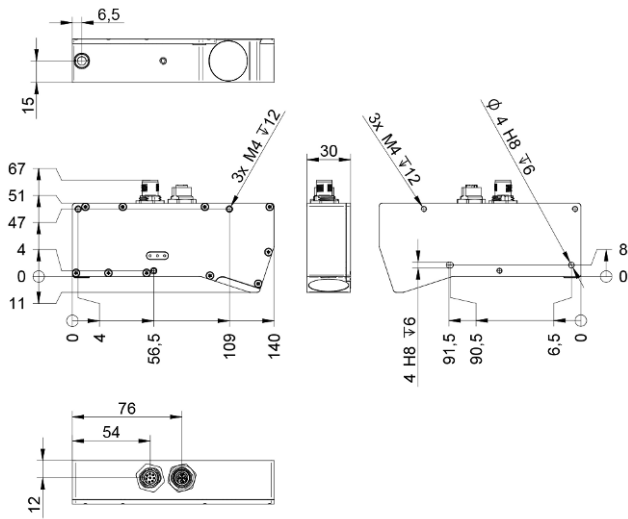

Dimensions specified in mm (1 mm = 0.03937")

3.5 Layout

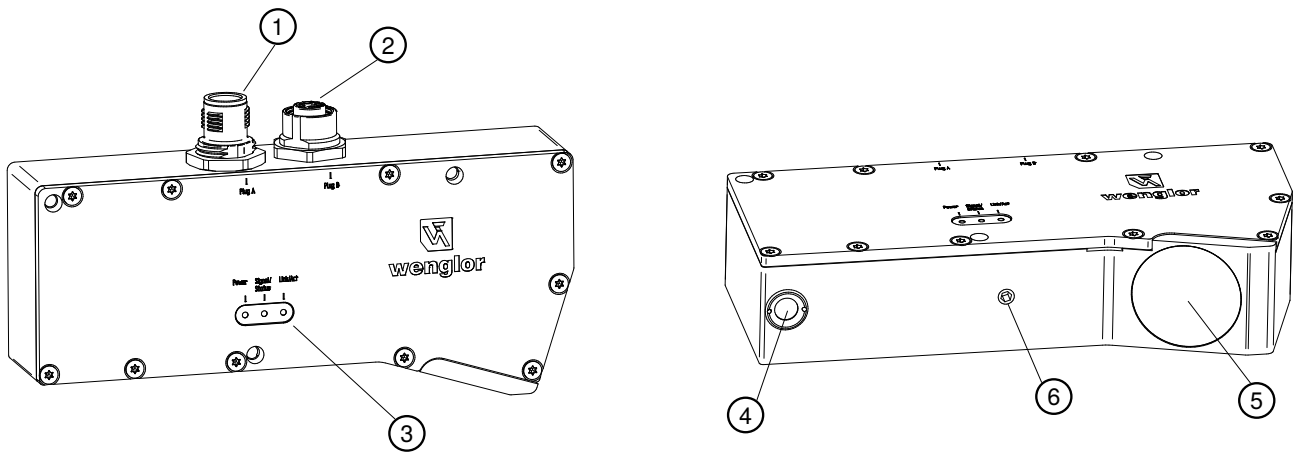

1	Voltage supply connector plug	2	Ethernet connection socket
3	LED Display	4	Laser Outlet
5	Receivers	6	Thread for mounting the protective screen retainer

3.6 Control Panel

A52

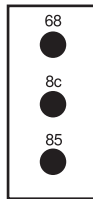

68 = supply voltage indicator

85 = Link/Act LED

8c = signal/status

Designation	Status	Function
Power	Blue	Operating voltage on
	Off	Operating voltage off
Signal/status	Green	Signal strength OK, sensor ready to measure
	Blinking green	Weak signal, unreliable measurement results
	Red	No signal, sensor contaminated and/or outside the measuring range
Link/act	Yellow	Link included (TCP/IP)
	Blinking yellow	Communication
	Green	EtherCAT active

3.7 Complementary Products

wenglor offers you the right connection and mounting technology as well as other accessories for your product. You can find this at www.wenglor.com on the product details page at the bottom.

3.8 Scope of delivery

- Sensor
- Safety precaution
- Calibration protocol
- BEF-SET-21 mounting set

4 Transport and Storage

4.1 Transport

Upon receipt of shipment, the goods must be inspected for damage in transit. In the case of damage, conditionally accept the package and notify the manufacturer of the damage. Then return the device, making reference to damage in transit.

4.2 Storage

The following points must be taken into consideration with regard to storage:

- Do not store the product outdoors.
- Store the product in a dry, dust-free place.
- Protect the product against mechanical impacts.
- Protect the product against exposure to direct sunlight.



NOTICE

Risk of property damage in case of improper storage!

The product may be damaged.

→ Storage instructions must be complied with.

5 Installation and Electrical Connection

5.1 Installation

- Protect the product from contamination during installation.
- Observe all applicable electrical and mechanical regulations, standards and safety rules.
- Protect the product against mechanical influences.
- Make sure that the sensor is mounted in a mechanically secure fashion.

Direct eye contact with the laser beam must be avoided when installing the sensor. The laser warning label must be attached in the visible area.

When installing the sensor it must be ensured that the measuring beam is exactly perpendicular to the surface to be measured to assure accurate measurement results. An unexact alignment results in a geometrically longer measuring path.

Moving or Striped Objects

If moving or striped objects will be measured, the sensor head should be mounted with its long side perpendicular to the motion of direction or the stripes. In this way, optimal measurement results can be achieved in the corners because shadowing is avoided:

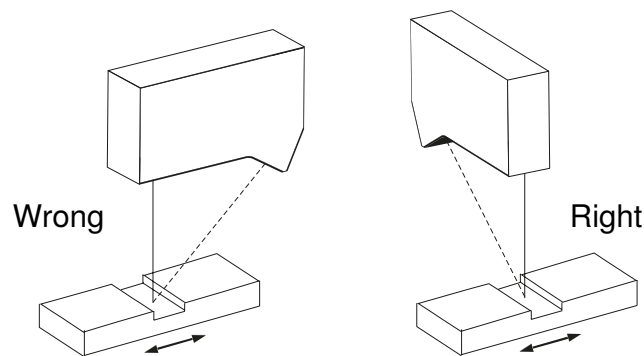

NOTICE

Risk of property damage in case of improper installation!

The product may be damaged!

→ Comply with installation instructions.



CAUTION

Risk of personal injury or property damage during installation!

Personal injury and damage to the product may occur.

→ Ensure a safe installation environment.

5.2 Electrical Connection

- Wire the sensor in accordance with the connection diagram.
- Switch on the supply voltage (see section Technical Data [► 10])



⚠ DANGER

Risk of personal injury or property damage due to electric current.

Voltage-conducting parts may cause personal injury or damage to equipment.

→ The electric device may be connected by appropriately qualified personnel only.

Connection diagram Supply Voltage

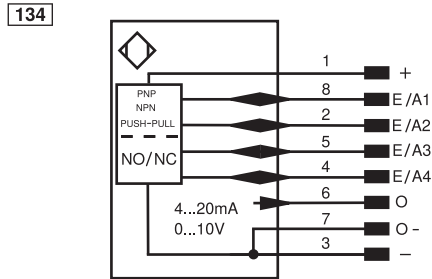

Connection diagram Ethernet

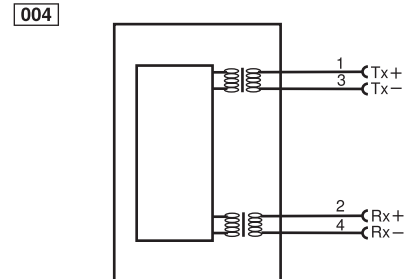

Two connector plugs are integrated in to the sensor's housing. The 8-pin plug supplies the sensor with +24 V operating voltage, whereas communication for parameters configuring and process data is conducted via the 4-pin socket.

Legend					
+	Supply Voltage +	PT	Platinum measuring resistor	ENARs422	Encoder A/Ā (TTL)
-	Supply Voltage 0 V	nc	Not connected	ENBRs422	Encoder B/B̄ (TTL)
~	Supply Voltage (AC Voltage)	U	Test Input	ENA	Encoder A
A	Switching Output (NO)	Ū	Test Input inverted	ENb	Encoder B
Ā	Switching Output (NC)	W	Trigger Input	AMIN	Digital output MIN
V	Contamination/Error Output (NO)	W-	Ground for the Trigger Input	AMAX	Digital output MAX
Ṽ	Contamination/Error Output (NC)	O	Analog Output	AoK	Digital output OK
E	Input (analog or digital)	O-	Ground for the Analog Output	SY In	Synchronization In
T	Teach Input	BZ	Block Discharge	SY OUT	Synchronization OUT
R	Reset input	Amv	Valve Output	OLT	Brightness output
Z	Time Delay (activation)	a	Valve Control Output +	M	Maintenance
S	Shielding	b	Valve Control Output 0 V	rsv	Reserved
RxD	Interface Receive Path	SY	Synchronization	Wire Colors according to DIN IEC 60757	
TxD	Interface Send Path	SY-	Ground for the Synchronization	BK	Black
RDY	Ready	E+	Receiver-Line	BN	Brown
GND	Ground	S+	Emitter-Line	RD	Red
CL	Clock	⊥	Grounding	OG	Orange
E/A	Output/Input programmable	SnR	Switching Distance Reduction	YE	Yellow
	IO-Link	Rx+/-	Ethernet Receive Path	GN	Green
PoE	Power over Ethernet	Tx+/-	Ethernet Send Path	BU	Blue
IN	Safety Input	Bus	Interfaces-Bus A(+)/B(-)	VT	Violet
OSSD	Safety Output	La	Emitted Light disengageable	GY	Grey
Signal	Signal Output	Mag	Magnet activation	WH	White
BI_D+/-	Ethernet Gigabit bidirect. data line (A-D)	RES	Input confirmation	PK	Pink
ENo RS422	Encoder 0-pulse 0/0̄ (TTL)	EDM	Contacting Monitoring	GNYE	Green/Yellow

5.3 Troubleshooting



INFORMATION

Required action in case of fault:

1. Shut down the machine.
2. Analyze and eliminate the cause of error with the aid of the diagnostics information.
3. If the error cannot be eliminated, please contact wenglor's support department.
4. Do not operate in case of indeterminate malfunctioning.
5. The machine must be shut down if the error cannot be definitively explained or properly eliminated.



DANGER

Risk of personal injury or property damage in case of non-compliance!

The system's safety function is disabled. Personal injury and damage to equipment may occur.

→ Required action as specified in case of fault.

6 Function Description

PNBC laser distance sensors use a high-resolution CMOS linear image sensor and determine the distance by means of triangulation at a sampling rate of up to 30 kHz. The sensor is equipped with integrated electronics and no additional controller is required as a result.

Measured distance values are read out as process data via the interface and at the analogue output with 16-bit resolution.

The diffusely reflected light from the measuring point is crucial for this measurement. An LED signal lamp on the sensor control panel indicates if the intensity of the reflected light is too low. To provide accurate measurement results, the sensor automatically adjusts its laser power and exposure time to the sample's reflectance. Various automatic and manual modes are provided to control the exposure. The "Exposure Control" section [▶ 19] provides detailed information.

The laser's light point generates an intensity curve on the CMOS linear image sensor, which is distributed over several pixels. This intensity curve is referred to as the peak in the following. The peak's curve or position depends on the distance, the internal optics and the surface of the object to be measured. The evaluation method is decisive with regard to attainable measuring accuracy. Some surfaces require a specifically-adapted evaluation method. Possible evaluation methods are described in the "Evaluation Methods" section [▶ 21]. PNBC sensors accurately measure the distance to objects regardless of the materials used, e.g., metal, plastic, ceramic, rubber or paper. In the case of highly reflective surfaces or liquids, the sensors to be used must be checked on a case-by-case basis and correct installation must be ensured.

The encoder input can be used to synchronize several sensors with each other or to trigger the measurement by a trigger signal. The required settings are described in "Operation with A/B Channel Encoder [▶ 25]" section.

The functions and parameters of the sensor (see section 9 [▶ 33]) and wTeach2 display software (see wTeach2 Configuration Software [▶ 37]) can be activated or set via TCP/IP command (see interface protocol Ethernet TCP/IP [▶ 38]) or via EtherCAT (see Interface Protocol EtherCAT [▶ 55]). The respective subsections include the corresponding commands and adjustment limits.

6.1 Network Settings

The sensor is in "Ethernet TCP/IP" network mode when delivered and can be accessed via the integrated website (Settings via Website [▶ 33]) or via the TCP/IP interface (Interface Protocol Ethernet TCP/IP [▶ 38]). The following settings can be made for the network configuration.

Function	Possible settings	Default
IP address	Unique IP address in the network. The IP address can be changed via the website without power interruption. When changing via TCP/IP or wTeach2, a power interruption is required to activate the new address.	192.168.0.225
IP address and subnet mask	Subnet mask of the network. The subnet mask can be changed via the web page without power interruption. When changing by TCP/IP command, a power interruption is required to activate the new address.	255.255.0.0
Gateway address	Gateway address in the network. The gateway address can be changed via the website without power interruption. When changing by TCP/IP command, a power interruption is required to activate the new address.	169.254.150.1
Function	Possible settings	Default
EtherCAT	The sensor can be switched to EtherCAT mode via the website.	Deactivated



INFORMATION

To switch back from EtherCAT mode to Ethernet TCP/IP mode, an EtherCAT master is required, as the EthernetEnable register must be written for this. See Interface Protocol EtherCAT [▶ 55]

6.2 Exposure Control

The sensor projects a laser light point onto the object and maps it onto the CMOS image sensor on the receiver side. The sensor has an electronic shutter to regulate the amount of light falling on the CMOS line. The amount of laser light can also be varied by changing the laser light output.

With automatic control, the sensor automatically adjusts the exposure time t_s and/or the laser power so that an optimal signal for distance measurement is available (figure, red curve). The sensor operates with a fixed, adjustable measuring rate f , so that a maximum exposure time $t_{s,max}$ can be used depending on the set measuring rate, whereby $t_{s,max}$ is limited by the set measuring rate f .

If the exposure time, laser power or object reflectance is too low, a reduced, non-optimal peak height is achieved, which reduces the measuring accuracy or prevents the measurement (see figure, purple curve).

The background level of the peak (figure, blue curve) increases with external light and can lead to reduced measuring accuracy or an incorrect measurement. In general and especially in the case of increased levels of ambient light in the application, it is recommended to minimize the influence of external light by reducing the exposure time $t_{s,max}$. An automatically controlled laser power ensures that sufficient light is always available and that a high dynamic can be used due to reflectance changes of the objects to be measured (figure, green curve).

To view the CMOS image sensor signal, either the wTeach2 software can be used (see wTeach2 Configuration Software [▶ 37]) or the image sensor signal can be called up via TCP/IP interface (see Peak Data [▶ 52])

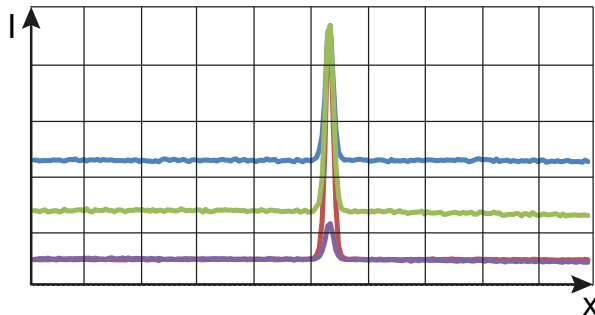

Function	Possible settings	Default
Exposure mode	<p>The exposure preset selects a combination of measuring rate, control mode, exposure time and laser power for predefined use cases.</p> <p>For most applications, the “Maximum measuring rate, good black sensitivity” preset is recommended. In this setting, a large dynamic range with high sensitivity is covered at the maximum possible measuring rate by controlling the exposure time and laser power.</p> <p>The exposure presets can be activated via the TCP/IP interface or the integrated web server.</p> <p>An exposure preset can also be set manually by setting the individual tabs Exposure mode, Measuring rate, Maximum exposure time, Fixed exposure time, Maximum laser power, and Fixed laser power.</p> <p>0: Individual: The values of the parameters relevant for exposure do not correspond to any exposure time mode and can be selected individually.</p> <p>1: Maximum measuring rate, good black sensitivity: Measuring rate 30 kHz, automatic exposure time control, maximum exposure time 29 μs, automatic laser power control</p>	0: Individual

Function	Possible settings	Default
	<p>2: Maximum measuring rate, high resistance to external light: Measuring rate 30 kHz, automatic exposure time control, maximum exposure time 5 μs, automatic laser power control</p> <p>3: High black sensitivity: Measuring rate 20 kHz, automatic exposure time control, maximum exposure time 50 μs, automatic laser power control</p> <p>4: Maximum black sensitivity Measuring rate 10 kHz, automatic exposure time control, maximum exposure time 200 μs, automatic laser power control</p> <p>5: Laser class 1: Measuring rate 10 kHz, automatic exposure time control, maximum exposure time 100 μs, fixed laser power control with laser power setting 390 μs</p> <p>Note: This setting limits the laser power to the limit value of 390 μW applicable in laser class 1. However, the device cannot therefore be classified as a class 1 laser device in accordance with EN 60825-1, as operation with class 2 laser power is still possible by switching.</p> <p>6: Low jitter, maximum measuring rate, good black sensitivity: Measuring rate 30 kHz, fixed exposure time of 29 μs, auto laser power control</p> <p>7: Low jitter, maximum measuring rate, high resistance to external light: Measuring rate 30 kHz, fixed exposure time of 5 μs, auto laser power control</p>	
Laser power and exposure regulator	<p>Automatic exposure time or laser power control can be activated and deactivated</p> <p>0: Automatic exposure time and laser power control</p> <p>1: Automatic exposure time control, manually adjustable laser power control</p> <p>2: Automatic laser power control, manually adjustable exposure time control</p> <p>3: Exposure time and laser power control manually adjustable.</p> <p>In the case of laser power control and exposure time control, the sensor automatically selects the setting which results in the best pixel intensity. Either exposure time or laser power control may be preferable depending on the application. If a constant exposure time is desired, laser power control is suitable. If constant laser power is desired, exposure time control is more suitable.</p> <p>Note: The automatic exposure time control has a faster control speed compared to the laser power control.</p>	0

Function	Possible settings	Default
Measuring rate	The measuring rate can be set between 750...30,000 Hz. Note: The measuring rate is the central variable for the possible exposure times, i.e. if the maximum or fixed exposure time is selected greater than the maximum possible exposure time for the set measuring rate, the sensor limits the exposure time to the possible maximum.	10 kHz
Exposure time	The current set exposure time with automatic exposure time control can be queried via the website.	
Maximum exposure time	The maximum exposure time setting can be used to limit the automatic exposure time control (control mode 0 or 1). This is particularly beneficial in strong ambient light. The maximum exposure time that is adjusted by the device results from the measuring rate and the value set here. Exposure time must be less than the limit $t_{s,max} = 1/\text{measurement rate} - 3.725 \mu\text{s}$. If larger values are set, the $t_{s,max}$ is used.	200 μs
Fixed exposure time	If the automatic exposure time control is not active, a fixed exposure time can be selected. Control mode 2 or 3 includes this combination. 1.6...200 μs	n.a.
Laser power	The currently set laser power can be read off on the website or queried via TCP/IP command.	
Fixed laser power	The fixed laser power can be preselected in control modes 1 and 3. 0.03...0.9 mW	n.a.
Transmitting light (laser)	The transmitting light can be switched on or off either via the Ethernet interface or via the pin function of a user input/output. If a transmitting light is deactivated there is no usable measured value If the pin function for an input/output has been set to the input function laser on/off, the control of the transmitting light via Ethernet interface is deactivated and the pin status is dominant.	On

6.3 Evaluation Method

Function	Possible settings	Default
Evaluation process	The evaluation of the line signal intensity curve can be carried out with different evaluation methods 2: FCOG 3: FCOG filter 4: MEDIAN 5: EDGE Note: In most cases, the FCOG evaluation method offers the best compromise between resolution and robustness	2
Protective screen compensation	Compensates for the distance error when using the accessory protective screens	off

6.3.1 Center of Gravity (FCOG)

The FCOG evaluation method calculates the peak's center of gravity, whose X-coordinate is the sought crude result. For the center of gravity analysis, the signal is filtered and the peak is roughly localized. The center of gravity is then formed around the peak over a small interval. With 16-bit resolution, the measured values are highly precise thanks to this evaluation method.

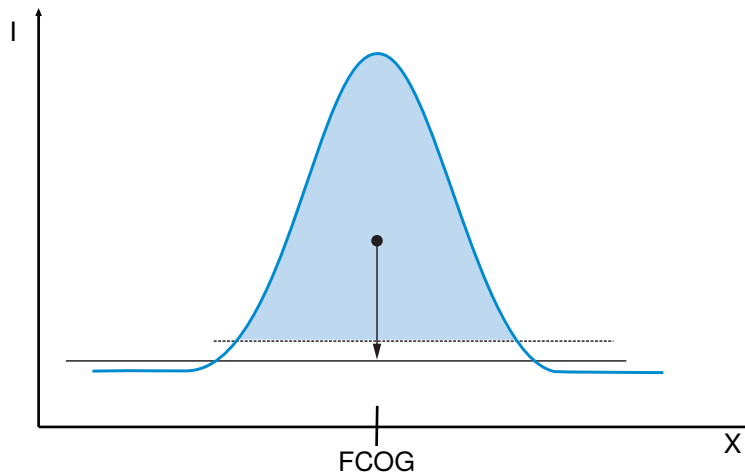

6.3.2 MEDIAN

The MEDIAN evaluation method calculates the x-coordinate of the peak based on the median. For calculation, the peak is localized in the same way as the FCOG evaluation method and split into two sub-intervals of the same area. The peak position corresponds to the limit of the two partial intervals. The median is less susceptible to errors due to noise at the flanks of the peak compared to the FCOG. A resolution of 16 bits is achieved

6.3.3 FCOG Filter

The FCOG filter evaluation method calculates the x-coordinate of the peak in the same way as the FCOG method, but is widened before evaluating the peak via an additional smoothing filter. This makes it possible to merge individual subpeaks into an overall peak, particularly for objects with a strong surface structure, so that the subsequent FCOG algorithm takes all peak components into account. The evaluation method is recommended for special applications where the FCOG or MEDIAN method poses problems. The algorithm achieves a resolution of 16 bits.

6.3.4 Flanks (Edge)

The EDGE process evaluates the flanks of the peak. The advantage of this evaluation method is the fact that the peak's asymmetrical crests, caused for example by speckle effects resulting from a sheet metal panel, are excluded from the evaluation. With edge evaluation, the measured values achieve a 11-bit resolution.

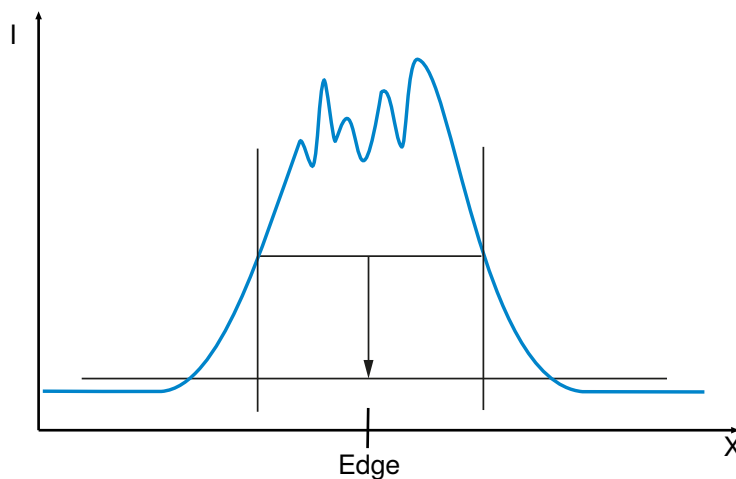

6.4 Input/Output Functions (E/A)

6.4.1 Pin Functions

Various pin functions can be selected for the individual inputs/outputs. Depending on the setting as input or output, there are corresponding further parametrization options that influence the behavior.

Pin	Possible settings	Default
E/A1 to E/A4	<p>Switching output:</p> <p>The selected pin acts as a switching output</p> <p>Teach-in input for A1</p> <p>Teach-in input for A2</p> <p>Teach-in input for A3</p> <p>Teach-in input for A4</p> <p>Encoder input:</p> <p>The two pins E/A1 and E/A2 can be configured together as an encoder input in pairs. This allows the sensor to be operated in combination with a two-channel rotary encoder with HTL signal or with a trigger at one of the inputs. See section 8.3.5 The function is not available for pins E/A3 and E/A4</p> <p>Encoder reset input:</p> <p>The encoder counter is set to "0".</p> <p>Laser-off input:</p> <p>The laser can be switched on or off by activating the input</p> <p>Error output:</p> <p>Output switches when the selected minimum and maximum intensity is exceeded or undershot or when the measured object is outside the measuring range.</p> <p>Note:</p> <p>The intensity thresholds set are not identical to the signal strength indication in the status indicator</p>	<p>E/A1: Teach-In A3</p> <p>E/A2: Teach-In A4</p> <p>E/A3: Switching output</p> <p>E/A4: Switching output</p>

6.4.2 Output Functions

Function	Possible settings	Default
PNP/NPN/push-pull	<p>PNP</p> <p>The load or the analysis module is connected between the minus pole (reference) and the output. When the sensor is switched, the output is connected to the plus pole via an electronic switch. The switching signal is maintained when a pull-down resistor is connected.</p> <p>NPN</p> <p>The load or the analysis module is connected between the plus pole (reference) and the output. When the sensor is switched, the output is connected to the minus pole via an electronic switch. The switching signal is maintained when a pull-up resistor is connected.</p>	<p>E/A3: PNP</p> <p>E/A4: PNP</p>

Function	Possible settings	Default
	Push-pull Alternate PNP and NPN switching	
NC/NO	Normally Open Contact (NO) The output is closed when the condition has been satisfied, depending on settings (switching point, warning, error). Normally Closed Contact (NC) The output is open when the condition has been satisfied, depending on settings (switching point, warning, error).	E/A3: NO E/A4: NO

6.4.3 Input Functions

The input functions are used to set the physical inputs.

Function	Possible settings	Default
Input mode	Operating voltage active The function stored at the respective pin (see Pin Functions [▶ 23]) is triggered as soon as operating voltage is applied to the input. Operating voltage inactive The function stored at the respective pin (see Pin Functions [▶ 23]) is triggered as soon as 0 V is applied to the input or the input is not assigned.	Operating voltage active
Input load	The input load of 2 mA can be switched off, e.g. if the PLC has a high-impedance PNP output.	Active

6.5 Switching Point Functions

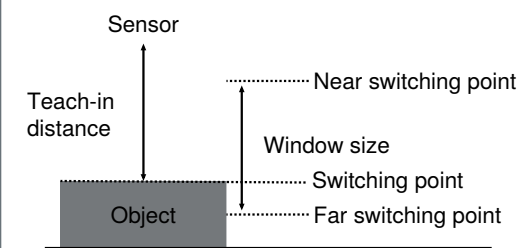
Function	Possible Settings	Default
Teach-in mode FT (Window teach-in)	<p>There are two switching points in the case of window teach-in. The distance between the two switching points is called the window. The dimensions of the window are referred to as the window size (adjustable). The sensor is switched when an object is within the window.</p>  <p>The diagram illustrates the window teach-in process. A sensor is positioned above an object. The distance between the sensor and the object is labeled 'Teach-in distance'. A horizontal line represents the 'Switching point'. A vertical double-headed arrow indicates the 'Window size', which is the distance between the 'Near switching point' and the 'Far switching point'. The object is shown within this window.</p>	
Teach-in mode VT (Foreground teach-in)	Teach-in is performed while the sensor is aligned to the object. The switching distance is then automatically set to a distance which is slightly greater than the clearance between the sensor and the object. The sensor is thus switched for all objects whose distance to the sensor is equal to or less than the distance to the object used for the teach-in procedure.	

Function	Possible Settings	Default
Switching point	The setting of the LaserActive Register has no effect in this case.	32768
Switching hysteresis	The switching hysteresis is the difference between the switch-on and switch-off point. 0...1/4 of the measuring range	2
Switching reserve	Switching reserve is clearance between the teach-in distance and the sensor's switching point. Switching reserve ensures reliable object detection even in the case of slightly fluctuating distances between the objects and the sensor. Switching reserve can only be set for foreground teach-in mode. 0...1/4 of the measuring range	0
Window size	In window teach-in mode, the window size is used to determine the distance between switching point 1 and switching point 2. 0... Measuring range	1300

6.6 Encoder Input

Two channels (typically A/B) of an HTL encoder with a high output voltage between 5 V and 30 V can be connected to the encoder inputs I1 and I2. The sensor can then add the current rotation angle to the current measured value and transfer both values together via its process data. The sensor and rotary encoder must have the same reference potential GND. The counting direction can be changed by swapping inputs I1 and I2. In addition, an encoder reset signal that resets the encoder counter can be connected to one of the remaining input pins.

Channel A is phase-shifted 90° relative to channel B. It must be assured that a shielded cable is used in order to avoid possible interference or crosstalk between the conductors. Inputs I1 and I2 must be used as encoder inputs. The setting is made via the website or via TCP/IP or EtherCAT commands.

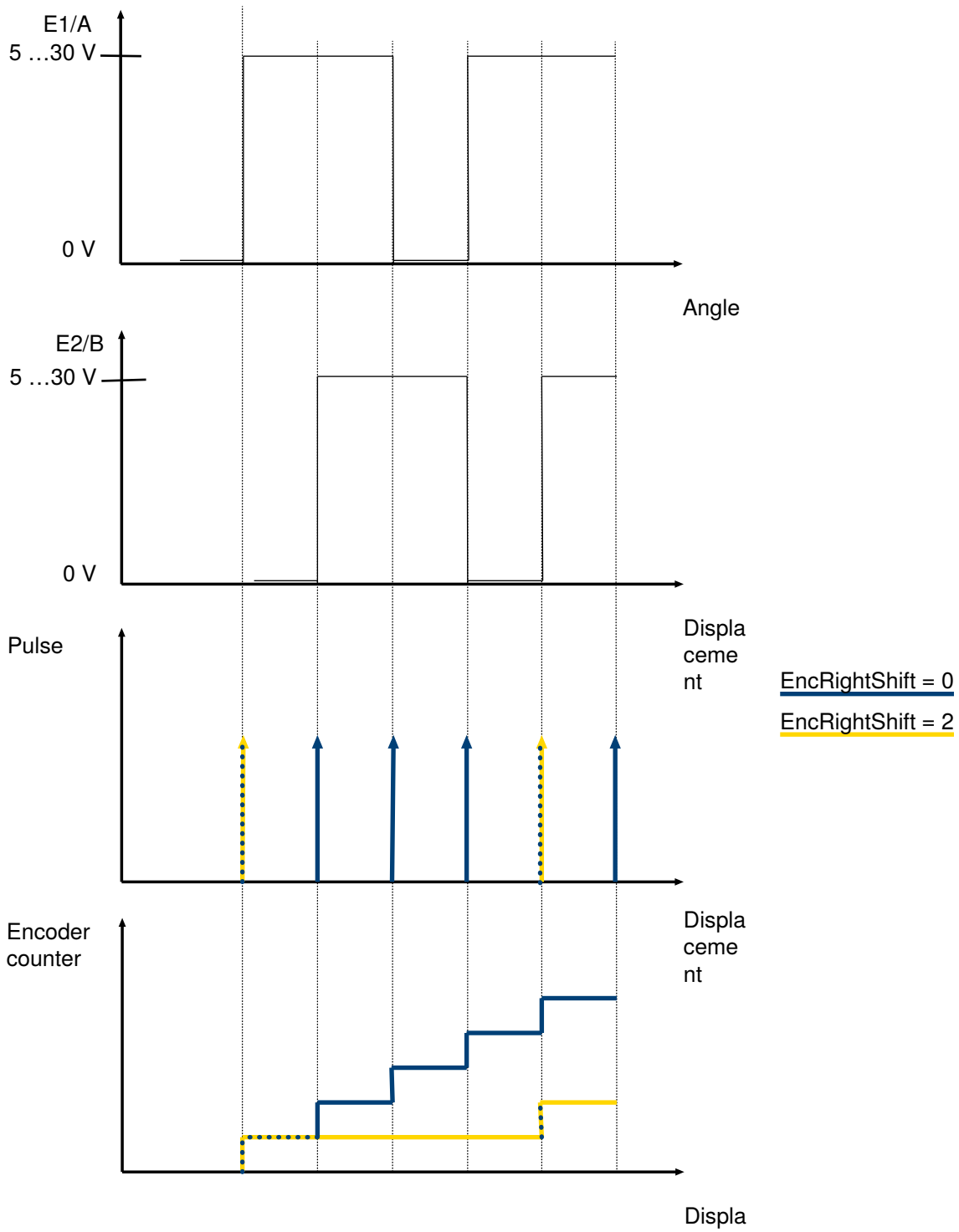

INFORMATION

The maximum input frequency at the encoder inputs is 500 kHz (90° phase shift between channel A and B, assuming pulse duty factor 1/2). This means that it is possible to work with a maximum encoder pulse rate of 2 MHz.

The encoder pulses increase/decrease the encoder counter value by 1 each time. The encoder counter value at the time of measurement capture is output in “Advanced continuous measurement” and “Peak data” mode via the digital TCP/IP interface or via the EtherCat interface. See Selecting the “Extended Continuous Measurement” Data Format [► 38] or Selecting the Data Format for Peak Data [► 38].

In the case of high-frequency encoders, every second, fourth, eighth, sixteenth... encoder pulse can be counted using the encoder right shift n, thus delaying/reducing an overrun of the 16-bit encoder counter value. The setting is made via the website or via the TCP/IP commands or the EtherCAT interface.

6.7 Analog Output

The measured value of the sensor is proportional to the current or voltage value of the analog output. The analog output is linear.

Function	Possible settings	Default
Analog mode	<p>Current output 4...20 mA The connected load should be $\geq 1 \text{ k}\Omega$.</p> <p>Voltage output 0...10 V The connected load should be $\leq 400 \Omega$.</p>	Current

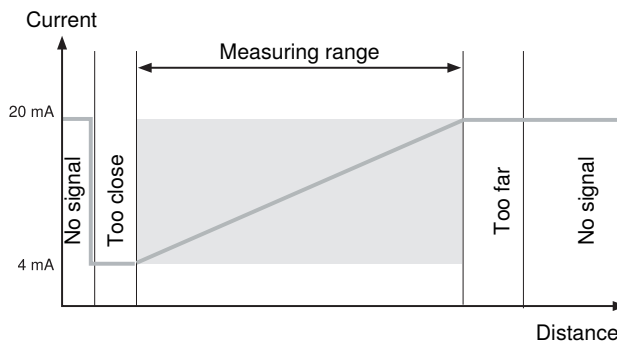
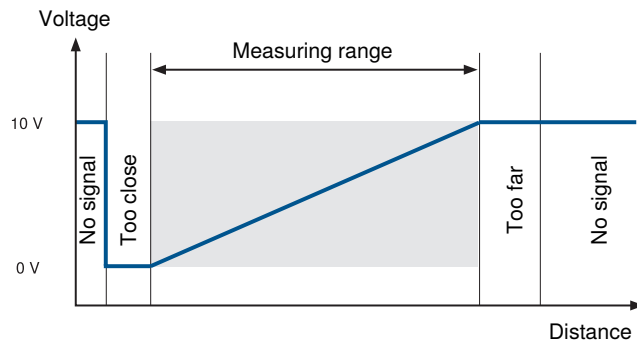

6.8 Condition Monitoring Functions

6.9 Digital Read-Out of Measured Values

The measured values distance, intensity and encoder counter can be transmitted via the digital protocols TCP/IP or EtherCAT.

Measured value	Explanation
Distance	The peak position determined from the x-coordinate of the signal peak (Evaluation Method [▶ 21]) is calibrated in the factory and can be output via the digital interfaces.
Intensity	The peak height of the signal peak (measured from the threshold or baseline) is output via the digital interface. This value can be used for intensity measurements with constant exposure time and laser power.
Encoder counter	The encoder counter is incremented/decremented with each encoder pulse and can be output together with the distance and intensity values. When using an encoder right shift $n > 0$, only every $2^{n^{\text{th}}}$ power of 2 is counted.

In Ethernet TCP/IP mode, several measured values are combined into one data package and transferred with a header from settings and metadata. The number of measured values per package can be adjusted. For more information on the structure of the packages, see Header and Data Format [▶ 49]. In Ethernet TCP/IP mode, all measured values up to the highest measuring rate of 30 kHz can be transmitted without loss.

In Ethernet TCP/IP mode, the output of the linear image sensor signal is still possible. For this purpose, the 1024 intensity values of the CMOS pixels are output and transferred together with a header from measured values, settings and metadata. For more information on the structure of the packages, see Header and Data Format [▶ 49].

Ethernet TCP/IP mode is activated by default. This means that the sensor can be controlled via a TCP/IP interface and operated via a website when delivered.

In EtherCAT mode, the measured values distance, intensity and encoder are transmitted in real time via the process data. The output rate in this mode is limited to a maximum value of 1 kHz.

The measured values transmitted in Ethernet TCP/IP or EtherCAT mode (distance, intensity and encoder) can be influenced and filtered by the following functions.

Function	Possible settings	Default
Measured value filter	The switchable measured value filter is a rolling mean value filter with length M and supplies the result of the averaging over the last M distance values as the distance output value. Invalid distance values with substitute value 65536 or 0 are not included in the averaging. This ensures that a brief dropout of the signal does not affect the mean value. In the event of incorrect measurements, e.g. due to a concealed receiver, 65535 is immediately output as the measured value. The condition of the filter is not affected by incorrect measurements. Each measurement is averaged with the valid previous measurements. In the case of long phases of incorrect measurements, these measurements can be far back in time. A bigger filter improves the sensor's reproducibility and smooths the signal waveform. The higher the filter number, the longer the sensor's response time when the measured values change. 0.1 = off 2...1,000	0
Offset	The Offset function is used to change the momentary measured value to a specified value. The switching thresholds and the analog measuring ranges are adapted along with this value. The offset value is added to the current distance. The offset also affects the analog output and the switching outputs.	0 μm
Ethernet output filter condition	The distance values output via the digital interface can be reduced, e.g. to obtain a lower output rate. In EtherCAT mode, the filter condition is not available. Instead, the filter condition "sampling, one from N" is automatically set with the best possible matching sampling/downsampling parameter N during parametrization of an output rate. In TCP/IP mode, the following parametrizations are possible:	0

Function	Possible settings	Default
	0: Output all measurements 1: Sampling, one from N In the case of sampling, every nth measured value is output. The effective output rate can be retrieved in the data packet or by command. 2: Encoder changed 3: Encoder increased (trigger mode) 4: Encoder decreased (trigger mode) In the case of encoder condition modes, the output of the measured values is linked to an encoder condition. For details, see separate section Distance Measurement with Encoder Output Filter [► 29].	
Sampling/downsampling parameters	The sampling parameter N is used when the output filter is set to Sampling. If scanning is activated, every nth measured value is output. 1...32767	1
Encoder counter right shift	Encoder counter right shift n reduces the pulse frequency on the encoder counter. Every second pulse is counted. 0...8	0
Encoder reset	The encoder counter is set to 0	

6.9.1 Distance Measurement with Encoder Output Filter

In the output filter mode with encoder condition, only one measured value is output via the TCP/IP interface if the encoder value changes. It is possible to switch between the modes

- Encoder changed
- Encoder increased (trigger mode)
- Encoder decreased (trigger mode)

The encoder counter right shift is applied before the comparison operation between the previous and current encoder counter value.

The measured values to be output according to the above conditions are collected and sent in packages over TCP/IP.



INFORMATION

The package size of the TCP/IP output can be adjusted, see Header and Data Format [► 49].

The encoder signal is detected with frequencies up to the cutoff frequency of the encoder filter and the resulting encoder counter value is used as a decision criterion for the output.

6.9.2 Distance Measurement with Single-Channel Trigger

If a trigger is to be implemented via the encoder input, only channel A or B should be connected and the unused channel must be connected to GND. Channel A corresponds to input E/A1 with encoder setting and channel B corresponds to input E/A2.

If channel B is to GND, each rising edge of trigger channel A increases the encoder value by 1 and each falling edge decreases by 1.

In order to obtain only one measured value per rising edge of the trigger signal, the Output filter trigger should be set to encoder increased.



INFORMATION

In the “Output filter trigger” mode, a measured value is output at the next possible time after the trigger pulse. A higher measurement frequency reduces the possible latency between trigger signal and measured value capture

Example: Measuring rate 30 kHz, maximum exposure time 5 μ s. The measured value output was recorded with a time inaccuracy of $1/30$ kHz = 33 μ s compared to the trigger signal.



INFORMATION

The maximum trigger rate of a single-channel trigger signal with a duty cycle of $1/2$ must not exceed $1/4$ of the measuring rate. Otherwise, trigger pulses may be skipped.

6.10 Measuring Accuracy and Error Influence

6.10.1 Calibration Report

A calibration report is included with the sensor, which graphically represents linearity error as a percentage for the measured value on a diffuse white surface.

The following is an example of a calibration report:

Example:

Calibration Protocol



Order Number: PNBC108.A
Serial Number: 020042
Production Number: 1328332
MAC Address: 54:4A:05:0A:4E:4D

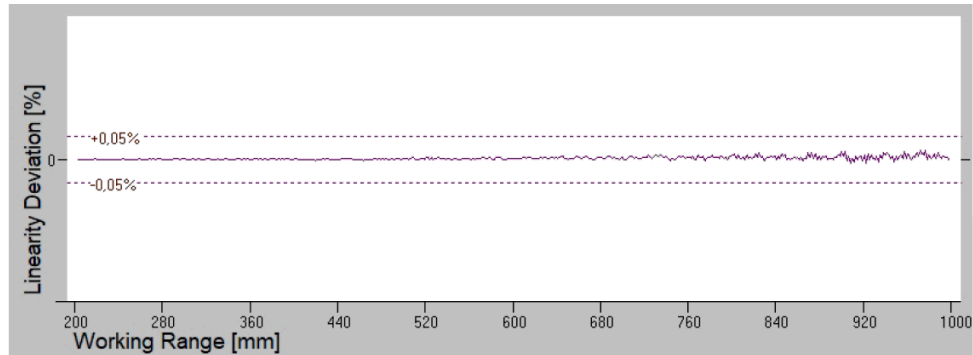

Measurement Conditions:

Measuring Range	800 mm
Working Range	200...1000 mm
Measured Surface	White
Evaluation Method	COG
Temperature	20° C (+/-1° C)
Laser Class	2 (max 1.0 mW)

Differences to the above data can appear due to:

1. Target material and surface
2. Target geometry
3. Sensor mounting
4. Temperature fluctuation during the measurement
5. Strong circulation of warm air between sensor and target

Further statements in the datasheet and the operation instructions are valid.

Inspector:
Date: 04.06.2024

6.10.2 Surface Structure and Condition of the Object to Be Measured

The condition and structure of the surface of the object being measured can influence the quality of the measured value. The structure and remission of surface elements within the laser light spot always influence the determined distance value. The result can be influenced by selecting an adapted algorithm.

In the case of moving objects with a textured or rough surface, the measured value may fluctuate when the surface is crossed, but the average measured value (see section Evaluation Method [▶ 21]) remains constant when the textured surface is scanned. Choosing a suitable average filter minimizes unwanted deflections.

6.10.3 Ambient Light

Ambient light can impair the capture of measured values. Therefore, when installing the sensor, care must be taken to avoid direct or reflected sunlight in the receiver optics. If this is not possible, the influence of ambient light can be reduced by selecting the shortest possible exposure time and the largest possible laser power.



INFORMATION

In order to achieve the highest possible resistance to ambient light, the shortest possible maximum exposure time should be set.

7 Settings via Website

Settings on the device can be adjusted via the integrated website with which the PNBC sensors are equipped. This website works independently of the operating system. The sensor can be conveniently parameterized via a web browser. The web-based configuration interface is not required for normal operation with a controller.

7.1 Accessing the Website

To access the product's website, the IP address must be entered in the address line of the browser. The home page / initial page appears with general information concerning the connected sensor.



INFORMATION

To access the website, the sensor and the end device with web browser must be in a compatible IP and subnet mask range. Note the factory default network parameters IP address (192.168.0.225) and subnet mask (255.255.0.0)

The screenshot shows a web browser window with the URL 192.168.0.225/index.htm. The website features a blue header with the Wenglor logo and the tagline 'the innovative family'. A navigation menu on the left includes 'Home', 'Network Settings', 'Basic Settings', and 'I/O Settings'. The main content area displays a 3D rendering of several blue PNBC108.A sensors. To the right, a 'Status' box provides real-time data: Measured value: 790,148 mm; I1: 0; I2: 0; O3: 0; O4: 0; Measurement rate: 30000 Hz; Shutter time: 1.600 us; Laser power: 0.78 mW; Signal strength: 100%; Temperature: +31 °C Ok!; Encoder: 0. Below the sensor image, three tables list product details, hardware/firmware information, and the calibration protocol.

Order number	PNBC108.A
Product version	A
Producer	Wenglor Sensoric
Description	High Performance Distance Sensor
Serial number	PNBC108_A_020042
MAC Address	54-4A-05-0A-4E-4D

Hardware version	1.0.0
Firmware version	5.3.3release_candidate2
EtherCAT COM	Unknown
EtherCAT APP	Unknown

Calibration protocol	PNBC108_A_020042.pdf
----------------------	----------------------

The left-hand column of the website contains the menu for accessing various information and settings pages.

In the right-hand column there is a status field that displays automatically updated live data of important sensor parameters. For a description of the individual parameters, see section Function Description [► 18].

7.2 Network Settings

The network settings of the sensor can be changed on the “Network Settings” subpage. The sensor can also be set to EtherCAT mode.

Changing network settings requires confirmation by entering the password “admin”. After entering the password and confirming, the sensor will restart and be unavailable for a short time.

Note: Note that changing the network parameters may mean that the device can no longer be found in the network. In the case of an unknown IP address or subnet mask, use the wTeach2 tool to correct the network setting via > wTeach2 configuration software.



INFORMATION

Please note that activating EtherCAT mode means that the device can no longer be reached via the website, wTeach2 and TCP/IP interface. To deactivate EtherCAT mode, use an EtherCAT capable controller.

The screenshot displays the 'Network Settings' page of the wenglor sensor's web interface. The browser window shows the URL '192.168.0.225/network.htm'. The page layout includes a navigation sidebar on the left with options for 'Home', 'Network Settings', 'Basic Settings', and 'IO Settings'. The main content area is divided into two sections: a configuration form and a status panel. The configuration form contains the following fields and values:

- IP address: 192.168.0.225
- Subnet mask: 255.255.0.0
- Standard gateway: 169.254.150.1
- Ethernet mode (EtherCAT): IP (Webserver, TCP)
- Password: (empty)

Below the form is an 'Ok' button and a warning: 'Important: Access to settings may get lost. Reboots automatically!'. The status panel on the right provides the following data:

- Measured value: 790,148 mm
- I1: 0
- I2: 0
- O3: 0
- O4: 0
- Measurement rate: 30000 Hz
- Shutter time: 1.600 us
- Laser power: 0.78 mW
- Signal strength: 100%
- Temperature: +31 °C Ok!
- Encoder: 0

The footer of the page contains contact information for wenglor sensoric GmbH, including the address 'wenglor Straße 3, 88069 Tettnang, Germany', phone numbers '+49 7542 5399-0' and '+49 7542 5399-988', and email 'info(at)wenglor.com'. It also includes links for 'Legal Disclaimer', 'Privacy Policy', and 'Links | Liability | Privacy Statement'.

7.3 Basic Adjustment Parameters

Basic adjustment parameters that influence the measurement performance and behavior of the sensor can be set on the “**Basic Settings**” subpage.



INFORMATION

Resetting the device to “Default values” resets all sensor parameters to the factory settings, except for the network settings.

The screenshot shows the Wenglor web interface for a sensor. The browser address bar shows the URL `192.168.0.225/device.htm`. The interface includes a navigation menu on the left with options: Home, Network Settings, Basic Settings, and I/O Settings. The main content area is divided into several sections:

- Measurement value computations:** Includes fields for Offset (0.000 mm), Average filter (2, 1000, 0: Off), Evaluation method (FCOG Filter), and Screening Grid (checkbox).
- Timing and Exposure:** Includes Exposure mode (Maximum measurement rate, good blade), Measurement rate (30000 Hz), Automatic shutter control (checked), Maximum shutter time (29.000 us), Fixed shutter time (--- us), Automatic laser power control (checked), Maximum laser power (1.00 mW), and Fixed laser power (--- mW).
- Ethernet Output:** Includes Filter condition (Output all measurements), Encoder counter right shift (0), and Encoder reset (Reset button).
- Reset:** Includes Default values (Reset button).

A Status panel on the right displays the following information:

- Measured value: 790,185 mm
- I1: 0
- I2: 0
- O3: 0
- O4: 0
- Measurement rate: 30000 Hz
- Shutter time: 1.600 us
- Laser power: 0.78 mW
- Signal strength: 100%
- Temperature: +31 °C Ok!
- Encoder: 0

7.4 Input/Output Functions

The “I/O Settings” subpage can be used to parameterize the input/output functions of the sensor at the physical pins and the behavior of the analog output.

PNBC x +

192.168.0.225/settings_io1.htm

Choose a language



Home

Network Settings

Basic Settings

I/O Settings

Analog Output

Analog Mode: 4..20mA

I/O 1 I/O 2 I/O 3 I/O 4

Pin Function: Encoder II+I2

2mA Input load: On

Input setting: Ub activ

Status

Measured value: 790,234 mm

I1: 0

I2: 0

O3: 0

O4: 0

Measurement rate: 30000 Hz

Shutter time: 1.600 us

Laser power: 0.78 mW

Signal strength: 100%

Temperature: +31 °C OK!

Encoder: 0

Legal Disclaimer

Print

wenglor sensoric GmbH

wenglor Straße 3

88069 Tettnang

Germany

Contact

+49 7542 6399-0

+49 7542 6399-988

info(at)wenglor.com

Privacy Policy

Links | Liability | Privacy Statement

Trademark | Google Analytics

E&OE

8 wTeach2 Configuration Software

For information on installing and connecting the wTeach2 software and its structure, as well as information on the general functions, see the wTeach2 operating instructions. They can be found online in the download area at www.wenglor.com under order number DNNF005.

8.1 wTeach2 Functions

Selected functions according to the function description can be set using the wTeach2 operating software. Process data such as distance and intensity measured values, as well as temperature and measuring rate can be displayed to support sensor integration. wTeach2 offers the option of outputting the linear image sensor signal.



INFORMATION

If the IP address is unknown, the sensor can be found using wTeach2 and the network configuration can be changed without knowing the IP address.

9 Interface Protocol Ethernet TCP/IP

This section describes the structure and function of the TCP commands for controlling and adjusting the PNBC1xx high-precision laser distance sensor with firmware version 5.3.3 and higher.

The commands are sent via port 3000. After opening the port, the device transmits data packets without any further prompting.

Further information regarding the header and the data format can be found in Header and Data Format [▶ 49].

It's advisable to stop the measurement before configuring the parameters.



INFORMATION

Upper and lower case letters must be observed.

Numbers must generally be entered via the TCP/IP interface with a decimal separator as . Ensure that the format specified in the following section is adhered to, including the number of decimal places appended, if applicable.



INFORMATION

Set commands are only acknowledged with a response when Reply Mode [▶ 39] is activated.

9.1 General Measuring Commands

9.1.1 Selecting the “Continuous Distance Measurement” Data Format

Command	set_measure_start<CR>
Response	Data stream
Description	Starts the “continuous measurement data stream [▶ 49] “(distance data).

9.1.2 Selecting the “Extended Continuous Measurement” Data Format

Command	set_ext_measure_start<CR>
Response	Data stream
Description	Starts the “extended continuous measurement data stream “(distance, intensity and encoder data).

9.1.3 Stop Measurement

Command	set_measure_stop<CR>
Response	No response
Description	The data stream is stopped and no more measurement data is transferred.

9.1.4 Selecting the Data Format for Peak Data

Command	set_peak<CR>
Response	Data stream
Description	A peak is transmitted.

9.1.5 Package Length

Command (set)	set_packet_size=x<CR>
Command (query)	get_packet_size=x<CR>
Response	OK:packet_size=x<CR>
Description	Number of distance values per packet. Possible values for “x” include: <ul style="list-style-type: none">• In the event of continuous measurement: 1...450• In the event of extended continuous measurement: 1...220 The entered value remains valid until the data format is changed. The values are then reset to the default values (150/450).

9.1.6 Fast Retransmissions

Command (set)	set_fast_retransmissions=x<CR>
Command (query)	get_fast_retransmissions<CR>
Response	OK:fast_retransmissions=x<CR>
Description	Enables fast sending of retransmissions in case of missing ACK. Note: For slow network connections, sending retransmissions quickly can lead to multiple retransmissions and disconnection. Possible values for “x” include: 0: Normal retransmissions (default) 1: Fast retransmissions

9.1.7 Reply Mode

Command	set_reply_echo_activate<CR> set_reply_echo_deactivate<CR>
Response	Only for “reply echo activate”: OK:reply_echo_activate<CR>
Description	All commands are acknowledged (default setting: mode deactivated).

9.2 Device Specific Information

9.2.1 Querying the Order Number

Command	get_name<CR>
Response	For example: OK:name=PNBC105<CR>
Description	The order number is read out.

9.2.2 Querying the Product Version

Command	get_pversion<CR>
Response	For example: OK:pversion=1.0.0<CR>
Description	The product version is read out.

9.2.3 Querying the Manufacturer

Command	get_manufacturer<CR>
---------	----------------------

Response	OK:manufacturer=wenglor_sensoric_GmbH<CR>
Description	The manufacturer is read out. Blanks are replaced with underlines!

9.2.4 Querying the Description

Command	get_description<CR>
Response	OK:description=High_Performance_Distance_Sensor<CR>
Description	The description is read out. Blanks are replaced with underlines!

9.2.5 Querying the Serial Number

Command	get_serial<CR>
Response	For example: OK:serial=001020<CR>
Description	The serial number is read out.

9.2.6 Querying the MAC Address

Command	get_mac_address<CR>
Response	For example: OK:mac_address=0007ABF00CAB<CR>
Description	The MAC address is read out.

9.2.7 Querying the Hardware Version

Command	get_hwversion<CR>
Response	For example: OK:hw_version=3.0.0<CR>
Description	The hardware version is read out.

9.3 Network Settings

9.3.1 IP Address

Command (set)	set_ip_addr=192.168.0.225<CR>
Command (query)	get_ip_addr<CR>
Response	OK:ip_addr=192.168.0.225<CR>
Description	The newly set IP address does not become active until after restarting.

9.3.2 Gateway Address

Command (set)	set_gateway_addr=192.168.0.1<CR>
Command (query)	get_gateway<CR>
Response	OK:gateway_addr=192.168.0.1<CR>
Description	The new gateway address does not become active until after restarting.

9.3.3 Reset Network Settings to Default Values

Command	set_activate_network_default<CR>
Response	OK:activate_network_default<CR>
Description	IP address, gateway and subnet mask are reset.

9.4 Measured Value Settings

9.4.1 Evaluation Method

Command (set)	set_calc_mode=x<CR>
Command (query)	get_calc_mode<CR>
Response	OK:calc_mode=x<CR>
Description	This command determines the peak evaluation method. Possible values for "x" include: 2: FCOG (default setting) 3: FCOG filter 4: MEDIAN 5: EDGE

9.4.2 Average Filter

Command (set)	set_avg_filter_cnt=x<CR>
Command (query)	get_avg_filter_cnt<CR>
Response	OK:avg_filter_cnt=x<CR>
Description	The rolling average is between 2 and 1,000. The smaller the selected value, the faster the measured value reacts to jumps. The larger the selected value, the more smoothed the measured value becomes. Possible values for "x" include: 0 (= off, default setting) 1: off 2...1.000

9.4.3 Measuring Rate

Command (set)	set_meas_freq=x<CR>
Command (query)	get_meas_freq<CR>
Response	OK:meas_freq=x<CR>
Description	The measuring rate is set and output in hertz. Possible values for "x" include: 750...30,000

9.4.4 Output Rate

Command (set)	set_freq=x<CR>
Command (query)	get_freq<CR>
Response	OK:freq=x<CR>
Description	Command outdated! Use the Output filter setting and the Downsampling parameter instead to influence the rate of the output measured values. The output rate is set and output in Hertz (default setting: 10,000 Hz). Possible values for "x" include: 1...30,000

9.4.5 Output Filter

Command (set)	set_ethernet_filter_condition=x<CR>
Command (query)	get_ethernet_filter_condition<CR>
Response	ethernet_filter_condition=x <CR>
Description	Allows setting and querying the output filter condition. Possible values for "x" include: 0: Output all measurements 1: Scan, one from N 2: Encoder changed 3: Encoder increased (trigger mode) 4: Encoder decreased (trigger mode)

9.4.6 Downsampling Parameters

Command (set)	set_n_sampling=x<CR>
Command (query)	get_n_sampling<CR>
Response	OK:n_sampling=x<CR>
Description	The downsampling parameter N can be set and output. The Downsampling parameter is in use when the output filter is set to Downsampling. Possible values for "x" include: 1...32767

9.4.7 Exposure Mode

Command (set)	set_exposure_preset=x<CR>
Command (query)	get_exposure_preset <CR>
Response	OK:exposure_preset=x<CR>
Description	Allows setting and querying the set exposure preset. set_exposure_preset collectively sets the settings required for the preset, which can also be individually set via set_regulator, set_meas_freq, set_max_shutter and set_shutter and set_laser_power. Possible values for "x" include: 0: Individual 1: Maximum measuring rate, good black sensitivity 2: Maximum measuring rate, high resistance to ambient light 3: High black sensitivity 4: Maximum black sensitivity 5: Laser class 1 6: Low jitter, maximum measuring rate, good black sensitivity 7: Low jitter, maximum measuring rate, high resistance to ambient light:

9.4.8 Control of Laser Power and Exposure Time

Command (set)	set_regulator=x<CR>
Command (query)	get_regulator<CR>
Response	OK:regulator=x<CR>
Description	Exposure time / laser power regulation is set here. Possible values for "x" include:

	<p>0: Automatic exposure time regulation AND laser power regulation (default setting)</p> <p>1: Automatic exposure time control, manually adjustable laser power control</p> <p>2: Automatic laser power control, manually adjustable exposure time control</p> <p>3: Exposure time and laser power control manually adjustable.</p> <p>In the case of laser power control and exposure time control, the sensor automatically selects the setting which results in the best pixel intensity. Either exposure time or laser power control may be preferable depending on the application. If a constant exposure time is desired, laser power control is suitable. If constant laser power is desired, exposure time control is more suitable.</p>
--	--

9.4.9 Switch Laser On/Off

Command (set)	<pre>set_activate_laser<CR> set_deactivate_laser<CR></pre>
Response	<pre>OK:activate_laser<CR> OK:deactivate_laser<CR></pre>
Description	The laser is switched on or off by means of TCP commands (default setting: laser on). If the pin function for an USRIO has been set to the input function laser on/off, the setting via USRIO is dominant and switching the transmitting light via command has no effect.

9.4.10 Fixed Laser Power

Command (set)	<pre>set_laser_power=x<CR></pre>
Command (query)	<pre>get_laser_power<CR></pre>
Response	<pre>OK:laser_power=x<CR></pre>
Description	<p>Setting and reading out the laser power with manual laser power control (regulator = 1 or 3) in mW.</p> <p>Possible values for “x” include: 0.03...0.9</p> <p>Format: x.yy mW. Adjustable in 0.01 mW increments</p> <p>Example: <pre>set_laser_power=0.31</pre></p>

9.4.11 Maximum Laser Power

Command (set)	<pre>set_max_laser_power =x<CR></pre>
Command (query)	<pre>get_max_laser_power <CR></pre>
Response	<pre>OK:max_laser_power=x<CR></pre>
Description	<p>Setting and reading out the maximum controlled laser power with automatic laser power control (regulator = 0 or 2) in mW.</p> <p>Possible values for “x” include: 0.03...0.9</p> <p>Format: x.yy mW. Adjustable in 0.01 mW increments</p> <p>Example: <pre>set_max_laser_power=0.31</pre></p>

9.4.12 Current Laser Power

Command (query)	<pre>get_current_laser_power <CR></pre>
Response	<pre>OK:current_laser_power=x<CR></pre>
Description	Readout of the currently applied laser power with automatic and manual laser power control in mW.

9.4.13 Fixed Exposure Time

Command (set)	set_shutter=x<CR>
Command (query)	get_shutter<CR>
Response	OK:shutter=x<CR>
Description	Setting and reading of the exposure time with manual exposure time control (regulator = 2.3) in μs . Possible values for "x" include: 1.6...200 Format: x.yyy μs . Adjustable in 0.025 μs increments Example: set_shutter=1.625

9.4.14 Maximum Exposure Time

Command (set)	set_max_shutter=x<CR>
Command (query)	get_max_shutter<CR>
Response	OK:max_shutter=x<CR>
Description	Setting and reading of the maximum exposure time with automatic exposure time control (regulator = 0 oder 1) in μs . Possible values for "x" include: 1.6...200 Format: x.yyy μs . Adjustable in 0.025 μs increments Example: set_max_shutter=20.625

9.4.15 Current Exposure Time

Command (query)	get_current_shutter<CR>
Response	OK:get_current_shutter=x<CR>
Description	Readout of the currently set exposure time with automatic or manual exposure time control in μs .

9.4.16 Offset

Command (set)	set_digout_offset=x<CR>
Response	OK:digout_offset=x<CR>
Description	A zero-point offset can be entered here. The offset is entered as a 16-bit value (default setting: 0). Possible values for "x" include: -30000...30000 Conversion of offset from digital to mm: Offset [mm] = x / 65536 × measuring range [mm]

9.4.17 Protective Screen Compensation

Command (set)	set_compensation_activate<CR> set_compensation_deactivate<CR>
Response	No response
Description	Activates or deactivates the protective screen compensation.

9.4.18 Encoder Reset

Command (set)	set_clear_encoder<CR>
Response	OK:clear_encoder<CR>
Description	The internal encoder counter is reset to zero.

9.4.19 Encoder Counter Right Shift

Command (set)	set_enc_right_shift=x<CR>
Command (query)	get_enc_rshift<CR>
Response	OK:enc_rshift=x<CR>
Description	The scaling factor of the encoder input is set and read out. Possible values for "x" include: 0: Each encoder edge is counted 1: Every 2nd encoder edge is counted 2: Every 4th encoder edge is counted (factory setting) ... 8: Every 256th encoder edge is counted

9.4.20 Reset to Default Values

Command (set)	set_activate_default<CR>
Response	OK:activate_default<CR>
Description	Resets all settings to factory settings except network settings.

9.5 I/O Settings

9.5.1 Analog Mode

Command (set)	set_anaout_mode=x<CR>
Command (query)	get_anaout_mode<CR>
Response	OK:anaout_mode=x<CR>
Description	Selecting the display mode. Possible values for "x" include: 1: 0...10 V 8: 4...20 mA (default setting)

9.5.2 Querying Input Status

Command (query)	get_usr_io1<CR> get_usr_io2<CR> get_usr_io3<CR> get_usr_io4<CR>
Response	Beispiel: OK:usr_io1=1<CR>
Description	Reads out the input status at the pin – possible values: 0 and 1

9.5.3 Querying the Input/Output Status of All Inputs/Outputs

Command (set)	get_usr_allinputs<CR>
Response	OK:usr_io_allinputs=0111<CR>

Description	<p>Provides the status of all inputs/outputs in the order IO4, IO3, IO2 and IO1.</p> <p>Possible values include:</p> <p>0 and 1</p> <p>The example answer above represents:</p> <p>IO4: 0 (inactive)</p> <p>IO3: 1 (active)</p> <p>IO2: 1 (active)</p> <p>IO1: 1 (active)</p>
-------------	---

9.5.4 Pin Function

Command (set)	<pre>set_usrio1_pin_function=x<CR> set_usrio2_pin_function=x<CR> set_usrio3_pin_function=x<CR> set_usrio4_pin_function=x<CR></pre>
Command (query)	<pre>get_usrio1_pin_function<CR> get_usrio2_pin_function<CR> get_usrio3_pin_function<CR> get_usrio4_pin_function<CR></pre>
Response	(z. B. I/O1): OK:usr_io1_pin_function=x<CR>
Description	<p>Selects the pin function.</p> <p>Possible values for "x" include:</p> <p>1: Switching output</p> <p>2: Ext. teach-in input for O1</p> <p>3: Ext. teach-in input for O2</p> <p>4: Ext. teach-in input for O3</p> <p>5: Ext. teach-in input for O4</p> <p>6: Encoder input (I1+I2)</p> <p>7: Encoder reset input</p> <p>10: Input laser on/off</p> <p>11: Error output</p>

9.5.5 Output

Command (set)	<pre>set_usrio1_output_mode=x<CR> set_usrio2_output_mode=x<CR> set_usrio3_output_mode=x<CR> set_usrio4_output_mode=x<CR></pre>
Command (query)	<pre>get_usrio1_output_mode<CR> get_usrio2_output_mode<CR> get_usrio3_output_mode<CR> get_usrio4_output_mode<CR></pre>
Response	(z. B. I/O1): OK:usr_io1_output_mode=x<CR>
Description	<p>Determination of the output mode.</p> <p>Possible values for "x" include:</p> <p>1: PNP</p> <p>2: NPN</p> <p>3: Push-pull</p>

9.5.6 Output Function

Command (set)	set_usrio1_output_function=x<CR>
---------------	----------------------------------

	<pre>set_usrio2_output_function=x<CR> set_usrio3_output_function=x<CR> set_usrio4_output_function=x<CR></pre>
Command (query)	<pre>get_usrio1_output_function<CR> get_usrio2_output_function<CR> get_usrio3_output_function<CR> get_usrio4_output_function<CR></pre>
Response	(z. B. I/O1): OK:usr_io1_output_function=x<CR>
Description	<p>Determining the output function.</p> <p>Possible values for “x” include:</p> <p>1: Normally Open (NO)</p> <p>2: Normally Closed (NC)</p>

9.5.7 Teach-In Mode

Command (set)	<pre>set_usrio1_teach_mode=x<CR> set_usrio2_teach_mode=x<CR> set_usrio3_teach_mode=x<CR> set_usrio4_teach_mode=x<CR></pre>
Command (query)	<pre>get_usrio1_teach_mode<CR> get_usrio2_teach_mode<CR> get_usrio3_teach_mode<CR> get_usrio4_teach_mode<CR></pre>
Response	(z. B. I/O1): OK:usr_io1_teach_mode=x<CR>
Description	<p>Determining the teach mode.</p> <p>Possible values for “x” include:</p> <p>1: Foreground teach-in (default setting)</p> <p>2: Window teach-in</p> <p>Foreground teach-in: Teach-in is performed while the sensor is aligned to the object. The teach-in distance is set automatically, so that the sensor is switched as soon as distance between the sensor and the object is less than or equal to the previously taught-in distance.</p> <p>Window teach-in: There are two switching points in the case of window teach-in. The distance between the two switching points is the window width. The sensor is switched when the object is within the window.</p>

9.5.8 Teaching In the Switching Distance

Command	<pre>set_usrio1_teach_in set_usrio2_teach_in set_usrio3_teach_in set_usrio4_teach_in</pre>
Response	(z. B. I/O1): OK:usr_io1_switch_dist_mm=87.614<CR>
Description	<p>Future setting values are automatically calculated and saved from the values currently recorded.</p> <p>Note:</p> <p>The pin function of the respective output must be configured as a switching output.</p>

9.5.9 Window Size

Command (set)	<pre>set_usrio1_window_size_mm=x<CR> set_usrio2_window_size_mm=x<CR> set_usrio3_window_size_mm=x<CR> set_usrio4_window_size_mm=x<CR></pre>
Command (query)	<pre>get_usrio1_window_size_mm<CR> get_usrio2_window_size_mm<CR></pre>

	get_usrio3_window_size_mm<CR> get_usrio4_window_size_mm<CR>
Response	(z. B. I/O1): OK:usr_io1_window_size_mm=x<CR>
Description	Determining the window width The entered value must be smaller than the sensor's measuring range. Example: 0.100 (specified in mm)

9.5.10 Changing the Switching Point

Command (set)	set_usrio1_switch_dist_mm=x<CR> set_usrio2_switch_dist_mm=x<CR> set_usrio3_switch_dist_mm=x<CR> set_usrio4_switch_dist_mm=x<CR>
Command (query)	get_usrio1_switch_dist_mm<CR> get_usrio2_switch_dist_mm<CR> get_usrio3_switch_dist_mm<CR> get_usrio4_switch_dist_mm<CR>
Response	(z. B. I/O1): OK:usr_io1_switch_dist_mm=x<CR>
Description	The switching point is shifted to the entered distance. In the case of foreground teach-in this is the teach-in distance, and in the case of window teach-in it's the distance to the middle of the window. The values for "x" must be within the working range, example: 22.123 (specified in mm).

9.5.11 Switching Hysteresis

Command (set)	set_usrio1_hysteresis_mm=x<CR> set_usrio2_hysteresis_mm=x<CR> set_usrio3_hysteresis_mm=x<CR> set_usrio4_hysteresis_mm=x<CR>
Command (query)	get_usrio1_hysteresis_mm<CR> get_usrio2_hysteresis_mm<CR> get_usrio3_hysteresis_mm<CR> get_usrio4_hysteresis_mm<CR>
Response	(z. B. I/O1): OK:usr_io1_hysteresis_mm=x<CR>
Description	Hysteresis describes the distance between the switch-on and switch-off points. Possible values for "x" include: 0...1/4 of the measuring range Example: 0.030 (specified in mm)

9.5.12 Switching Reserve

Command (set)	set_usrio1_switch_res_mm=x<CR> set_usrio2_switch_res_mm=x<CR> set_usrio3_switch_res_mm=x<CR> set_usrio4_switch_res_mm=x<CR>
Command (query)	get_usrio1_switch_res_mm<CR> get_usrio2_switch_res_mm<CR> get_usrio3_switch_res_mm<CR> get_usrio4_switch_res_mm<CR>
Response	(z. B. I/O1): OK:usr_io1_switch_res_mm=x<CR>
Description	Switching reserve is clearance between the teach-in distance and the sensor's switching point. Switching reserve ensures reliable object detection even in the case of slightly fluctuating distances between the objects and the sensor. Possible values for "x" include: 0...1/4 of the measuring range

	Example: 0.120 (specified in mm) Switching reserve can only be set for foreground teach-in.
--	--

9.5.13 Input Load

Command (set)	set_usrio1_input_load=x<CR> set_usrio2_input_load=x<CR> set_usrio3_input_load=x<CR> set_usrio4_input_load=x<CR>
Command (query)	get_usrio1_input_load<CR> get_usrio2_input_load<CR> get_usrio3_input_load<CR> get_usrio4_input_load<CR>
Response	(z. B. I/O1): OK:usr_io1_input_load=x<CR>
Description	Setting the input load. Possible values for "x" include: 1: Input load active (2 mA, default setting) 2: Input load inactive

9.5.14 Input Function

Command (set)	set_usrio1_input_function=x<CR> set_usrio2_input_function=x<CR> set_usrio3_input_function=x<CR> set_usrio4_input_function=x<CR>
Command (query)	get_usrio1_input_function<CR> get_usrio2_input_function<CR> get_usrio3_input_function<CR> get_usrio4_input_function<CR>
Response	(z. B. I/O1): OK:usr_io1_input_function=x<CR>
Description	Determining the input function. Possible values for "x" include: 1: Operating voltage active (pending tasks are executed when operating voltage is on, default setting) 2: Operating voltage inactive (pending tasks are executed when operating voltage = 0 V)

9.5.15 Minimum Intensity

Command (set)	set_usrio1_min_err_intens=x<CR> set_usrio2_min_err_intens=x<CR> set_usrio3_min_err_intens=x<CR> set_usrio4_min_err_intens=x<CR>
Command (query)	get_usrio1_min_err_intens<CR> get_usrio2_min_err_intens<CR> get_usrio3_min_err_intens<CR> get_usrio4_min_err_intens<CR>
Response	(z. B. I/O1): OK:usr_io1_min_err_intens=x<CR>
Description	Defines the minimum intensity value for the error output. Possible values for "x" include: 0...4095

9.6 Header and Data Format

After opening port 3000, the sensor transmits data packets in the selected data format (exception: peak data, Peak Data [► 52]).

The following data formats are possible:

- Continuous distance measurement (default setting)
- Extended continuous distance measurement
- Peak data

The header and the data are distributed to two TCP/IP packages of roughly the same size. In the case of a header with 94 bytes and data of 900 bytes (for a total of 994 bytes), the first package contains 496 bytes and the second package 498. The header is always at the beginning of the package, followed by the data.

The data layout is described in the following tables. The respective data format is identified by means of the "Data Format" field.

Example: If a value of 17520 appears in the "Data Format" field, this corresponds to continuous distance measurement.

All values are little-endian, i.e. the least significant byte comes first.

In the case of zero-terminated strings, the entry ends with the first "0". At the latest the last value must be a "0", i.e. one less byte is available for the entry. All zero-terminated strings are read out in ASCII code.



INFORMATION

All registers are specified as hexadecimal values.

9.6.1 Continuous Distance Measurement

This data format should be used for processes which do not require an encoder. All measured distance values are transmitted uninterruptedly.



INFORMATION

If the package length deviates from the default (see section Package Length [▶ 39]), the number of attached measured values per package changes accordingly.

Designation	Offset [bytes]	Length [bytes]	Type	Read-out/comment
Data format	0	4	unsigned int	17520
Internal	4	24		
Order number (zero-terminated)	28	12	string	PNBC102*
Serial number (zero-terminated)	40	12	string	001000*
Software version (zero-terminated)	52	10	string	V2.11*
Operating time counter in ms	62	4	unsigned int	1467*
Measuring range lower limit in mm	66	2	unsigned short	25*
Measuring range in mm	68	2	unsigned short	10*
Laser power in 0.1 mW	70	2	unsigned short	1...10
Measuring rate in Hz	72	2	unsigned short	900...30.000
Temperature in the sensor in °C	74	1	unsigned char	35*
Evaluation method	75	1	unsigned char	2, 5
Laser power / measuring rate control	76	1	unsigned char	0...3
EncRightShift	77	1	unsigned char	0...8
Status	78	1	unsigned char	0...255
Internal	79	8		

Designation	Offset [bytes]	Length [bytes]	Type	Read-out/comment
I/Ox and laser status	87	1	unsigned char	0...255
Output rate in Hz	88	2	unsigned short	1...30.000
Average filter	90	2	unsigned short	0...1.000
Offset	92	2	signed short	-30.000...+30.000
Number of distance values per packet	94	2	unsigned short	1...450
Distance	96	2		0...65.535
Distance 2	98			
.	.			
.	.			
Distance 450	994			

* Example value

9.6.2 Extended Continuous Measurement (Distance, Intensity, Encoder)

This data format should be selected when an encoder is used in the application. In this case, intensity and the encoder value (encoder counter in the PNBC) for each individual measurement are transmitted in addition to distance values. This makes it possible to obtain an actual position value synchronous to the distance values.



INFORMATION

If the package length deviates from the default (see section Package Length [► 39]), the number of attached measured values per package changes accordingly.

Designation	Offset [bytes]	Length [bytes]	Type	Read-out/comment
Data format	0	4	unsigned int	17536
Internal	4	24		
Order number (zero-terminated)	28	12	string	PNBC102*
Serial number (zero-terminated)	40	12	string	001000*
Software version (zero-terminated)	52	10	string	V2.11*
Operating time counter in ms	62	4	unsigned int	1.467*
Measuring range lower limit in mm	66	2	unsigned short	25*
Measuring range in mm	68	2	unsigned short	10*
Laser power in 0.1 mW	70	2	unsigned short	1...10
Measuring rate in Hz	72	2	unsigned short	900...30.000
Temperature in the sensor in °C	74	1	unsigned char	35*
Evaluation method	75	1	unsigned char	2...5
Laser power / measuring rate control	76	1	unsigned char	0...3
EncRightShift	77	1	unsigned char	0...8
Status	78	1	unsigned char	0...255
Internal	79	8		
I/Ox and laser status	87	1	unsigned char	0...255

Designation	Offset [bytes]	Length [bytes]	Type	Read-out/comment	
Output rate in Hz	88	2	unsigned short	1...30.000	
Average filter	90	2	unsigned short	0...1.000	
Offset	92	2	signed short	-30,000...+30,000	
Number of distance, intensity and encoder values per packet	94	2	unsigned short	1...150	
Distance 1	96	6	unsigned short	0...65.535	
Intensity 1	98				0...4.095
Encoder 1	100				0...65.535
.	.				
.	.				
.	.				
Distance 150	990				
Intensity 150	992				
Encoder 150	994				

* Example value

9.6.3 Peak Data

This data format is suitable for diagnosis purposes. All 1024 pixel intensities of the sensor's CMOS line array are transmitted. This data format is not retained after restarting: the device is automatically reset to the previously selected format.

Designation	Offset [bytes]	Length [bytes]	Type	Read-out/comment
Data format	0	4	unsigned int	17488
Internal	4	24		
Order number (zero-terminated)	28	12	string	PNBC102*
Serial number (zero-terminated)	40	12	string	001000*
Software version (zero-terminated)	52	10	string	V2.11*
Operating time counter in ms	62	4	unsigned int	1467*
Measuring range lower limit in mm	66	2	unsigned short	25*
Measuring range in mm	68	2	unsigned short	10*
Laser power in 0.1 mW	70	2	unsigned short	1...10
Measuring rate in Hz	72	2	unsigned short	900...30.000
Temperature in the sensor in °C	74	1	unsigned char	35*
Evaluation method	75	1	unsigned char	2..5
Laser power / measuring rate control	76	1	unsigned char	0...3
EncRightShift	77	1	unsigned char	0...8
Status	78	1	unsigned char	0...255
Internal	79	8		
I/Ox and laser status	87	1	unsigned char	0...255
Distance in digits	88	2	unsigned short	10...65.535
Intensity in digits	90	2	unsigned short	0...4.095
Encoder value in digits	92	2	signed short	0...65.535
Number of distance, intensity values per packet	94	2	unsigned short	1.024

Designation	Offset [bytes]	Length [bytes]	Type	Read-out/comment
Intensity, pixel 1	96	2	unsigned short	0...4.095
Intensity, pixel 2	98			
·	·			
·	·			
Intensity, pixel 1024	2124			

* Example value

9.6.4 Description of the Measurement Data

Status:

The status is represented as a status byte:

7	6	5	4	3	2	1	0
---	---	---	---	---	---	---	---

Bit 0: Out of range error: Intensity or distance is outside of the valid working range

Bit 1: Internal peak memory overflow error

Bit 2: Sensor FIFO overflow: CPU fails to process the measurement data

Bit 3...7: = 0

I/Ox and Laser Status:

The statuses of the inputs/outputs and the laser are represented as a I/O, laser byte:

7	6	5	4	3	2	1	0
---	---	---	---	---	---	---	---

Bit 0: Status E/A1

Bit 1: Status E/A2

Bit 2: Status E/A3

Bit 3: Status E/A4

Bit 7: Laser status: 1 = On; 0 = off

Distance in bit:

Distance is represented as a 16-bit value:

15	14	13	12	11	10	9	8	7	6	5	4	3	2	1	0
----	----	----	----	----	----	---	---	---	---	---	---	---	---	---	---

Bit 0...15: Distance measured value (0...65,535)

The following formula is used to arrive at the value displayed on the website:

Measured value in mm = (distance in bits * sensor measuring range in mm / 65536) + lower working range limit in mm

Example (PNBC105): Measured value = $35,721 \times 100 \text{ mm} / 65.536 + 90 \text{ mm} = 144.5 \text{ mm}$

Intensity Value:

The intensity byte contains the intensity value and is displayed as a 16-bit value:

15	14	13	12	11	10	9	8	7	6	5	4	3	2	1	0
----	----	----	----	----	----	---	---	---	---	---	---	---	---	---	---

Bit 0...11: Intensity value (= peak value, 0 to 4,095)

Bit 12: Reserved (=0)

Bit 13: Reserved (=0)

Bit 14: Errorbit: Intensity too low or too high

Bit 15: Errorbit: Distance is outside of the working range

Encoder Value:

The encoder value is represented as a 16-bit value:

15	14	13	12	11	10	9	8	7	6	5	4	3	2	1	0
----	----	----	----	----	----	---	---	---	---	---	---	---	---	---	---

Bit 0...15: Encoder value (0...65,535)

10 Interface Protocol EtherCAT

The website can be used to switch the Ethernet interface from TCP/IP to EtherCAT (see section Network Settings [▶ 34]).

EtherCAT is an industry standard that is real-time capable and offers easy connectivity to all EtherCAT compatible devices.



NOTICE

No Website Available

When EtherCAT mode is activated, the sensor website cannot be accessed and no commands can be executed via TCP/IP. If the sensor is to be switched from EtherCAT to TCP/IP, this must be done via the EtherCAT interface.

Index 0x1000 – Device Type

Sub index	Name element	Data type	Bits size	Access	Description	Default setting
0		UDINT	32	ro		

Index 0x1018 – Identity Object

Sub index	Name element	Data type	Bits size	Access	Description	Default setting
0	Number of elements	USINT	8	ro		04
1	Vendor ID	UDINT	32	ro		0x0000059B
2	Product code	UDINT	32	ro	PNBC101 PNBC102 PNBC103 PNBC104 PNBC105 PNBC106 PNBC107 PNBC108	0x053F2B65 0x053F2B66 0x053F2B67 0x053F2B68 0x053F2B69 0x053F2B6A 0x053F2B6B 0x053F2B6C
3	Revision number	UDINT	32	ro		
4	Serial number	UDINT	32	ro		

Index 0x10F8 - Timestamp Object

Sub index	Name element	Data type	Bits size	Access	Description	Default setting
0		ULINT	64	ro		

Index 0x1a00 - 1. TxPDO

Sub index	Name element	Data type	Bits size	Access	Description	Default setting
0	Number of elements	USINT	8	rw		03
1	PDO Object 1	UDINT	32	rw		0x30000110
2	PDO Object 2	UDINT	32	rw		0x30000210

Sub index	Name element	Data type	Bits size	Access	Description	Default setting
3	PDO Object 3	UDINT	32	rw		0x30000310

Index 0x1c12 - Sync Manager 1PDO Assignment

Sub index	Name element	Data type	Bits size	Access	Description	Default setting
0	Number of elements	USINT	8	rw		0
	Subindex 001	DT1C12ARR	16	rw		

Index 0x1c13 - Sync Manager 2PDO Assignment

Sub index	Name element	Data type	Bits size	Access	Description	Default setting
0	Number of elements	USINT	8	rw		0
	Subindex 001	DT1C13ARR	16	rw		0x1A00

Index 0x3000 - Inputs

Sub index	Name element	Data type	Bits size	Access	Description	Default setting
0	Number of elements	USINT	8	ro		03
1	Distance	UINT	16	ro	Distance value as 16-bit value. Conversion to 'mm' takes place via MeasurementRange and MeasurementBegin	0000
2	Intensity	UINT	16	ro	Intensity value as 16-bit value.	0000
3	Encoder	UINT	16	ro	Encoder value as 16-bit value.	0000

Index 0x4000 - Control

Sub index	Name element	Data type	Bits size	Access	Description	Default setting
0	Number of elements	USINT	8	ro		24
1	Measure Start	BOOL	1	rw	Starts/stops measurement	0
2	EthernetEnable	BOOL	1	rw	Switch between TCP/IP and EtherCAT. Setting the register to "True" instantly sets the sensor to TCP/IP mode.	0
3	Frequency	UDINT	32	rw	Setting/output of the output rate in Hertz. When setting the Frequency parameter, the sampling/downsampling parameter that best matches the measuring rate (MeasureFrequency) is selected (see section Digital Read-Out of Measured Values [▶ 27]).	

Sub index	Name element	Data type	Bits size	Access	Description	Default setting
					Values: 1...1.000	
4	MeasureFrequency	UDINT	32	rw	The measuring rate is set and output in hertz. Note: The maximum exposure time of the exposure time control is limited by the measuring rate, see section Exposure Control [► 19] Values: 750...30.000	10 kHz
5	CalcMode	UDINT	32	rw	Setting/output of the peak evaluation method. Values: 2: FCOG 3: FCOG filter 4: MEDIAN 5: EDGE	2
6	LaserActive	BOOL	1	rw	Switching the laser on/off. If the pin function for an USRIO has been set to the input function laser on/off, then the level at the pin is dominant. The setting of the LaserActive Register has no effect in this case. Values: <ul style="list-style-type: none"> ▪ 0: Laser off ▪ 1: Laser on 	1
7	LaserPower	UDINT	32	rw	Laser power can be adjusted in 1/10 mW increments. This setting is only active in the case of manual laser power regulation. Values: <ul style="list-style-type: none"> ▪ 0: 0.1 mW ... ▪ 10: 1 mW 	
8	Regulator	UDINT	32	rw	Setting/query of the measuring rate/laser power control. For laser power and exposure time control the sensor automatically selects the setting that gives the best pixel intensity. If constant laser power is desired, exposure time control is more suitable. Values: <ul style="list-style-type: none"> ▪ 0: Automatic exposure time and laser power control ▪ 1: Automatic exposure time control, manually adjustable laser power control 	0

Sub index	Name element	Data type	Bits size	Access	Description	Default setting
9	MeasurementRange	UINT	16	ro	Readout of the measuring range in mm	
10	MeasurementBegin	UINT	16	ro	Readout of the measuring range start in mm	
11	Temperature	USINT	8	ro	Reading the sensor temperature	
12	IP Address *	UDINT	32	rw	The IP address is only used in TCP/IP mode. The newly set IP address does not become active until after restarting. Input in hex format.	#C0A800E1
13	Subnet Mask Address *	UDINT	32	rw	The subnet mask is only used in TCP/IP mode. The new subnet mask does not become active until after restarting. Input in hex format	#FFFFFF00
14	Gateway Address *	UDINT	32	rw	The gateway address is only used in TCP/IP mode. The new gateway address does not become active until after restarting. Input in hex format	#A9FE9601

* Formats of IP address, subnet mask and gateway address:

Hex format: 0x | 00 | 00 | 01 to 0x | FF | FF | FF | FE
 Decimal format: 0 . 0 . 0 . 1 to 255 . 255 . 255 . 254

Sub index	Name element	Data type	Bits size	Access	Description	Default setting
15	Set Network Defaults	BOOL	1	rw	IP address, gateway and subnet mask are reset.	0
16	Average Filter	UINT	16	rw	The rolling average is between 2 and 1.000. The smaller the selected value, the faster the measured value reacts to jumps. The larger the selected value, the more smoothed the measured value becomes. Values: <ul style="list-style-type: none"> ▪ 0: off ▪ 1: off ▪ 2...1.000 	0
17	Protective Screen	BOOL	1	rw	Activates or deactivates the protective screen compensation. Values: <ul style="list-style-type: none"> ▪ 0: deactivated ▪ 1: activated 	0
18	Offset	INT	16	rw	Input of zero-point offset. The offset is entered as a 16-bit value. Conversion of offset from digital to mm: $\text{Offset [digits]} = \text{Offset [mm]} / \text{MeasurementRange} \times 65.536$ Values:	0

Sub index	Name element	Data type	Bits size	Access	Description	Default setting
					<ul style="list-style-type: none"> -30.000...30.000 	
19	Reset Encoder	BOOL	1	rw	Internal encoder counter is reset to zero	0
20	Encoder Shift	USINT	8	rw	Encoder input scaling factor. Values: <ul style="list-style-type: none"> 0: Every pulse is counted 1: Every 2nd pulse is counted 2: Every 4th pulse is counted ... 8: Every 256th pulse is counted 	2
21	Set Defaults	BOOL	1	rw	Resets all settings to factory settings except network settings.	0
22	FPGA FW version	STRING(16)	128	ro		
23	COM FW version	STRING(16)	128	ro		
24	APP FW version	STRING(16)	128	ro		

Index 0x5000 - USRIO Common

Sub index	Name element	Data type	Bits size	Access	Description	Default setting
0	Number of elements	USINT	8	ro		02
1	Analog Mode	USINT	8	ro	Selecting the display mode. Values: <ul style="list-style-type: none"> 1: 0...10 V 8: 4...20 mA 	8
2	USRIO status	USINT	8	ro	Query of input status at pins 1–4. The pin status is coded in bit 0–3.	0

Index 0x5100 - USRIO1

Sub index	Name element	Data type	Bits size	Access	Description	Default setting
0	Number of elements	USINT	8	ro		11
1	Pin Function	USINT	8	rw	Selects the pin function. Values: <ul style="list-style-type: none"> 0: Switching output 1: Ext. teach-in input for O1 2: Ext. teach-in input for O2 3: Ext. teach-in input for O3 4: Ext. teach-in input for O4 5: Encoder input (I1+I2) 6: Encoder reset input 9: Input laser on/off 10: Error output 	3

Sub index	Name element	Data type	Bits size	Access	Description	Default setting
2	Output Mode	USINT	8	rw	Determination of the output mode. Values: <ul style="list-style-type: none"> ▪ 0: PNP ▪ 1: NPN ▪ 2: Push-pull 	0
3	Output Function	USINT	8	rw	Determining the output function. Values: <ul style="list-style-type: none"> ▪ 0: Normally Open (NO) ▪ 1: Normally Closed (NC) 	0
4	Teach-in	BOOL	1	rw	Future setting values are automatically calculated and saved from the values currently recorded. The pin function of the respective output must be configured as a switching output.	0
5	Teach Mode	USINT	8	rw	Determining the teach mode. Foreground teach-in: Teach-in is performed while the sensor is aligned to the object. The teach-in distance is set automatically, so that the sensor is switched as soon as distance between the sensor and the object is less than or equal to the previously taught-in distance. Window teach-in: There are two switching points in the case of window teach-in. The distance between the two switching points is the window width. The sensor is switched when the object is within the window. Values: <ul style="list-style-type: none"> ▪ 0: Foreground Teach-In ▪ 1: Window teach-in 	0
6	Switching Point	UINT	16	rw	The switching point is shifted to the entered distance. In the case of foreground teach-in this is the teach-in distance, and in the case of window teach-in it's the distance to the middle of the window. The switching point is specified as a 16-bit value. Conversion in mm takes place via MeasurementRange and MeasurementBegin: Switching Point [digits] = (SwitchingPoint [mm] - MeasurementBegin[mm])/MeasurementRange [mm] × 65.536 Values: 0...65.535	32.768

Sub index	Name element	Data type	Bits size	Access	Description	Default setting
7	Hysteresis	UINT	16	rw	<p>Distance between switch-on and switch-off point.</p> <p>Hysteresis is specified as a 16-bit value.</p> <p>Conversion to mm is done via MeasurementRange:</p> $\text{Hysteresis [digits]} = \text{Hysteresis [mm]} / \text{MeasurementRange [mm]} \times 65536$ <p>Values:</p> <ul style="list-style-type: none"> ▪ 2...16.383 	2
8	Switch Reserve	UINT	16	rw	<p>Clearance between the teach-in distance and the sensor switching point. Switching reserve ensures reliable object detection even in the case of slightly fluctuating distances between the objects and the sensor.</p> <p>Switching reserve can only be set for foreground teach-in. Switch reserve is specified as a 16-bit value. Conversion to mm takes place via</p> <p>MeasurementRange:</p> $\text{Switch Reserve [digits]} = \text{Switch Reserve [mm]} / \text{MeasurementRange [mm]} \times 65.536$ <p>Values:</p> <ul style="list-style-type: none"> ▪ 0...16.383 	0
9	Window	UINT	16	rw	<p>Window is specified as a 16-bit value.</p> <p>Conversion to mm is done via MeasurementRange:</p> $\text{Window [digits]} = \text{Window [mm]} / \text{MeasurementRange [mm]} \times 65.536$ <p>Values:</p> <ul style="list-style-type: none"> ▪ 0...65.535 	1.300
10	Input Load	USINT	8	rw	<p>Determining the input load.</p> <p>Values:</p> <ul style="list-style-type: none"> ▪ 0: Input load activated (2 mA) ▪ 1: Input load inactive 	0
11	Input Function	USINT	8	rw	<p>Determining the input function.</p> <p>Operating voltage active: Pending tasks are executed when operating voltage is on.</p> <p>Operating voltage inactive: Pending tasks are executed when operating voltage is 0 V.</p> <p>Values:</p> <ul style="list-style-type: none"> ▪ 0: Operating voltage active ▪ 1: Operating voltage inactive 	0

Index 0x5200 - USRIO2

Sub index	Name element	Data type	Bits size	Access	Description	Default setting
0	Number of elements	USINT	8	ro		11
1	Pin Function	USINT	8	rw	<p>Selects the pin function.</p> <p>Values:</p> <ul style="list-style-type: none"> ▪ 0: Switching output ▪ 1: Ext. teach-in input for O1 ▪ 2: Ext. teach-in input for O2 ▪ 3: Ext. teach-in input for O3 ▪ 4: Ext. teach-in input for O4 ▪ 6: Encoder reset input ▪ 9: Input laser on/off ▪ 10: Error output 	4
2	Output Mode	USINT	8	rw	<p>Determination of the output mode.</p> <p>Values:</p> <ul style="list-style-type: none"> ▪ 0: PNP ▪ 1: NPN ▪ 2: Push-pull 	0
3	Output Function	USINT	8	rw	<p>Determining the output function.</p> <p>Values:</p> <ul style="list-style-type: none"> ▪ 0: Normally Open (NO) ▪ 1: Normally Closed (NC) 	0
4	Teach-in	BOOL	1	rw	<p>Future setting values are automatically calculated and saved from the values currently recorded.</p> <p>The pin function of the respective output must be configured as a switching output.</p>	0
5	Teach Mode	USINT	8	rw	<p>Determining the teach mode.</p> <p>Foreground teach-in: Teach-in is performed while the sensor is aligned to the object. The teach-in distance is set automatically, so that the sensor is switched as soon as distance between the sensor and the object is less than or equal to the previously taught-in distance.</p> <p>Window teach-in: There are two switching points in the case of window teach-in. The distance between the two switching points is the window width. The sensor is switched when the object is within the window.</p> <p>Values:</p> <ul style="list-style-type: none"> ▪ 0: Foreground Teach-In ▪ 1: Window teach-in 	0

Sub index	Name element	Data type	Bits size	Access	Description	Default setting
6	Switching Point	UINT	16	rw	<p>The switching point is shifted to the entered distance. In the case of foreground teach-in this is the teach-in distance, and in the case of window teach-in it's the distance to the middle of the window. The switching point is specified as a 16-bit value.</p> <p>Conversion in mm takes place via MeasurementRange and MeasurementBegin:</p> $\text{Switching Point [digits]} = (\text{SwitchingPoint [mm]} - \text{MeasurementBegin [mm]}) / \text{MeasurementRange [mm]} \times 65.536$ <p>Values: 0...65.535</p>	32.768
7	Hysteresis	UINT	16	rw	<p>Distance between switch-on and switch-off point.</p> <p>Hysteresis is specified as a 16-bit value.</p> <p>Conversion to mm is done via MeasurementRange:</p> $\text{Hysteresis [digits]} = \text{Hysteresis [mm]} / \text{MeasurementRange [mm]} \times 65.536$ <p>Values: ▪ 2...16.383</p>	2
8	Switch Reserve	UINT	16	rw	<p>Clearance in mm between the teach-in distance and the sensor switching point. Switching reserve ensures reliable object detection even in the case of slightly fluctuating distances between the objects and the sensor.</p> <p>Switching reserve can only be set for foreground teach-in. Switch reserve is specified as a 16-bit value. Conversion to mm takes place via MeasurementRange:</p> $\text{Switch Reserve [digits]} = \text{Switch Reserve [mm]} / \text{MeasurementRange [mm]} \times 65.536$ <p>Values: ▪ 0...16.383</p>	0
9	Window	UINT	16	rw	<p>Window is specified as a 16-bit value.</p> <p>Conversion to mm is done via MeasurementRange:</p> $\text{Window [digits]} = \text{Window [mm]} / \text{MeasurementRange [mm]} \times 65.536$ <p>Values:</p>	1.300

Sub index	Name element	Data type	Bits size	Access	Description	Default setting
					<ul style="list-style-type: none"> 0...65.535 	
10	Input Load	USINT	8	rw	Determining the input load. Values: <ul style="list-style-type: none"> 0: Input load activated (2 mA) 1: Input load inactive 	0
11	Input Function	USINT	8	rw	Determining the input function. Operating voltage active: Pending tasks are executed when operating voltage is on. Operating voltage inactive: Pending tasks are executed when operating voltage is 0 V. Values: <ul style="list-style-type: none"> 0: Operating voltage active 1: Operating voltage inactive 	0

Index 0x5200 – USRIO3

Sub index	Name element	Data type	Bits size	Access	Description	Default setting
0	Number of elements	USINT	8	ro		11
1	Pin Function	USINT	8	rw	Selects the pin function. Values: <ul style="list-style-type: none"> 0: Switching output 1: Ext. teach-in input for O1 2: Ext. teach-in input for O2 3: Ext. teach-in input for O3 4: Ext. teach-in input for O4 6: Encoder reset input 9: Input laser on/off 10: Error output 	0
2	Output Mode	USINT	8	rw	Determination of the output mode. Values: <ul style="list-style-type: none"> 0: PNP 1: NPN 2: Push-pull 	0
3	Output Function	USINT	8	rw	Determining the output function. Values: <ul style="list-style-type: none"> 0: Normally Open (NO) 1: Normally Closed (NC) 	0
4	Teach-in	BOOL	1	rw	Future setting values are automatically calculated and saved from the values currently recorded. The pin function of the respective output must be configured as a switching output.	0

Sub index	Name element	Data type	Bits size	Access	Description	Default setting
5	Teach Mode	USINT	8	rw	<p>Determining the teach mode.</p> <p>Foreground teach-in: Teach-in is performed while the sensor is aligned to the object. The teach-in distance is set automatically, so that the sensor is switched as soon as distance between the sensor and the object is less than or equal to the previously taught-in distance.</p> <p>Window teach-in: There are two switching points in the case of window teach-in. The distance between the two switching points is the window width. The sensor is switched when the object is within the window.</p> <p>Values:</p> <ul style="list-style-type: none"> ▪ 0: Foreground Teach-In ▪ 1: Window teach-in 	0
6	Switching Point	UINT	16	rw	<p>The switching point is shifted to the entered distance. In the case of foreground teach-in this is the teach-in distance, and in the case of window teach-in it's the distance to the middle of the window. The switching point is specified as a 16-bit value.</p> <p>Conversion in mm takes place via MeasurementRange and MeasurementBegin:</p> $\text{Switching Point [digits]} = (\text{SwitchingPoint [mm]} - \text{MeasurementBegin[mm]}) / \text{MeasurementRange [mm]} \times 65.536$ <p>Values:</p> <p>0...65.535</p>	32.768
7	Hysteresis	UINT	16	rw	<p>Distance in mm between switch-on and switch-off point.</p> <p>Hysteresis is specified as a 16-bit value.</p> <p>Conversion to mm is done via MeasurementRange:</p> $\text{Hysteresis [digits]} = \text{Hysteresis [mm]} / \text{MeasurementRange [mm]} \times 65.536$ <p>Values:</p> <ul style="list-style-type: none"> ▪ 2...16.383 	2
8	Switch Reserve	UINT	16	rw	<p>Clearance in mm between the teach-in distance and the sensor switching point. Switching reserve ensures reliable object detection even in the case of slightly fluctuating distances between the objects and the sensor.</p>	0

Sub index	Name element	Data type	Bits size	Access	Description	Default setting
					Switching reserve can only be set for foreground teach-in. Switch reserve is specified as a 16-bit value. Conversion to mm takes place via MeasurementRange: Switch Reserve [digits] = Switch Reserve [mm] / MeasurementRange [mm] × 65.536 Values: <ul style="list-style-type: none"> 0...16.383 	
9	Window	UINT	16	rw	Window is specified as a 16-bit value. Conversion to mm is done via MeasurementRange: Window [digits] = Window [mm] / MeasurementRange [mm] × 65.536 Values: <ul style="list-style-type: none"> 0...65.535 	1.300
10	Input Load	USINT	8	rw	Determining the input load. Values: <ul style="list-style-type: none"> 0: Input load activated (2 mA) 1: Input load inactive 	0
11	Input Function	USINT	8	rw	Determining the input function. Operating voltage active: Pending tasks are executed when operating voltage is on. Operating voltage inactive: Pending tasks are executed when operating voltage is 0 V. Values: <ul style="list-style-type: none"> 0: Operating voltage active 1: Operating voltage inactive 	0

Index 0x5200 – USRIO4

Sub index	Name element	Data type	Bits size	Access	Description	Default setting
0	Number of elements	USINT	8	ro		11
1	Pin Function	USINT	8	rw	Selects the pin function. Values: <ul style="list-style-type: none"> 0: Switching output 1: Ext. teach-in input for O1 2: Ext. teach-in input for O2 3: Ext. teach-in input for O3 4: Ext. teach-in input for O4 5: Encoder input (I1+I2) 6: Encoder reset input 	0

Sub index	Name element	Data type	Bits size	Access	Description	Default setting
					<ul style="list-style-type: none"> ▪ 9: Input laser on/off ▪ 10: Error output 	
2	Output Mode	USINT	8	rw	<p>Determination of the output mode.</p> <p>Values:</p> <ul style="list-style-type: none"> ▪ 0: PNP ▪ 1: NPN ▪ 2: Push-pull 	0
3	Output Function	USINT	8	rw	<p>Determining the output function.</p> <p>Values:</p> <ul style="list-style-type: none"> ▪ 0: Normally Open (NO) ▪ 1: Normally Closed (NC) 	0
4	Teach-in	BOOL	1	rw	<p>Future setting values are automatically calculated and saved from the values currently recorded.</p> <p>The pin function of the respective output must be configured as a switching output.</p>	0
5	Teach Mode	USINT	8	rw	<p>Determining the teach mode.</p> <p>Foreground teach-in: Teach-in is performed while the sensor is aligned to the object. The teach-in distance is set automatically, so that the sensor is switched as soon as distance between the sensor and the object is less than or equal to the previously taught-in distance.</p> <p>Window teach-in: There are two switching points in the case of window teach-in. The distance between the two switching points is the window width. The sensor is switched when the object is within the window.</p> <p>Values:</p> <ul style="list-style-type: none"> ▪ 0: Foreground Teach-In ▪ 1: Window teach-in 	0
6	Switching Point	UINT	16	rw	<p>The switching point is shifted to the entered distance. In the case of foreground teach-in this is the teach-in distance, and in the case of window teach-in it's the distance to the middle of the window. The switching point is specified as a 16-bit value.</p> <p>Conversion in mm takes place via MeasurementRange and MeasurementBegin:</p> <p>Switching Point [digits] = (SwitchingPoint [mm] - MeasurementBegin[mm])/MeasurementRange [mm] × 65.536</p>	32.768

Sub index	Name element	Data type	Bits size	Access	Description	Default setting
					Values: 0...65.535	
7	Hysteresis	UINT	16	rw	Distance in mm between switch-on and switch-off point. Hysteresis is specified as a 16-bit value. Conversion to mm is done via MeasurementRange: Hysteresis [digits] = Hysteresis [mm] / MeasurementRange [mm] × 65.536 Values: <ul style="list-style-type: none"> 2...16.383 	2
8	Switch Reserve	UINT	16	rw	Clearance in mm between the teach-in distance and the sensor switching point. Switching reserve ensures reliable object detection even in the case of slightly fluctuating distances between the objects and the sensor. Switching reserve can only be set for foreground teach-in. Switch reserve is specified as a 16-bit value. Conversion to mm takes place via MeasurementRange: Switch Reserve [digits] = Switch Reserve [mm] / MeasurementRange [mm] × 65.536 Values: <ul style="list-style-type: none"> 0...16.383 	0
9	Window	UINT	16	rw	Window is specified as a 16-bit value. Conversion to mm is done via MeasurementRange: Window [digits] = Window [mm] / MeasurementRange [mm] × 65.536 Values: <ul style="list-style-type: none"> 0...65.535 	1.300
10	Input Load	USINT	8	rw	Determining the input load. Values: <ul style="list-style-type: none"> 0: Input load activated (2 mA) 1: Input load inactive 	0
11	Input Function	USINT	8	rw	Determining the input function. Operating voltage active: Pending tasks are executed when operating voltage is on. Operating voltage inactive: Pending tasks are executed when operating voltage is 0 V.	0

Sub index	Name element	Data type	Bits size	Access	Description	Default setting
					Values: <ul style="list-style-type: none"> ▪ 0: Operating voltage active ▪ 1: Operating voltage inactive 	

11 Maintenance Instructions



NOTICE

This wenglor product is maintenance-free.

Cleaning and inspection of the plug connections at regular intervals are advisable.

Do not clean the product with solvents or cleaning agents that could damage the product.

The product must be protected against contamination during initial start-up.

12 Proper Disposal

wenglor sensoric GmbH does not accept the return of unusable or irreparable products. Respectively valid national waste disposal regulations apply to product disposal.

13 **Declarations of Conformity**

Declarations of conformity can be found on our website at www.wenglor.com in the product's separate download area.