

Retro-Reflex Sensor

Universal

P18L001

Part Number



- Adjustable switching distance
- Condition monitoring
- IO-Link 1.1
- Red light
- Stainless steel housing

The retro-reflex sensor works with red light and a reflector. It also reliably detects objects with reflective or glossy surfaces at high speeds. Thanks to its great range, the sensor can, for example, be used to manage feed and presence controls as well as to detect objects on wide feed belts. The IO-Link interface can be used to configure retro-reflective barriers (PNP/NPN, NC/NO, switching distance), as well as for reading out switching statuses and signal values.



Technical Data

Optical Data	
Range	6000 mm
Reference Reflector/Reflector Foil	RQ100BA
Switching Hysteresis	< 15 %
Light Source	Red Light
Polarization Filter	yes
Service Life (T = +25 °C)	100000 h
Max. Ambient Light	10000 Lux
Opening Angle	5 °
Two-Lens Optic	yes

Electrical Data	
Supply Voltage	10...30 V DC
Supply Voltage with IO-Link	18...30 V DC
Current Consumption (U _b = 24 V)	< 30 mA
Switching Frequency	1000 Hz
Switching frequency (speed mode)	1500 Hz
Response Time	0,5 ms
Response time (speed mode)	0,35 ms
Temperature Drift	< 10 %
Temperature Range	-10...60 °C
Switching Output Voltage Drop	< 2 V
PNP Switching Output/Switching Current	100 mA
Residual Current Switching Output	< 50 μA
Short Circuit Protection	yes
Reverse Polarity Protection	yes
Overload Protection	yes
Lockable	yes
Interface	IO-Link V1.1
Protection Class	III

Mechanical Data	
Setting Method	Potentiometer
Housing Material	Plastic, PBT
Housing Material	Stainless steel, V2A (1.4305 / 303)
Full Encapsulation	yes
Degree of Protection	IP67
Connection	M12 × 1; 4-pin

Safety-relevant Data	
MTTFd (EN ISO 13849-1)	3126,88 a

IO-Link	●
PNP NO	●

Connection Diagram No.	1026
Control Panel No.	D18
Suitable Connection Equipment No.	2
Suitable Mounting Technology No.	150

Complementary Products

IO-Link Master	
Reflector, Reflector Foil	
Software	

Ctrl. Panel

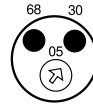
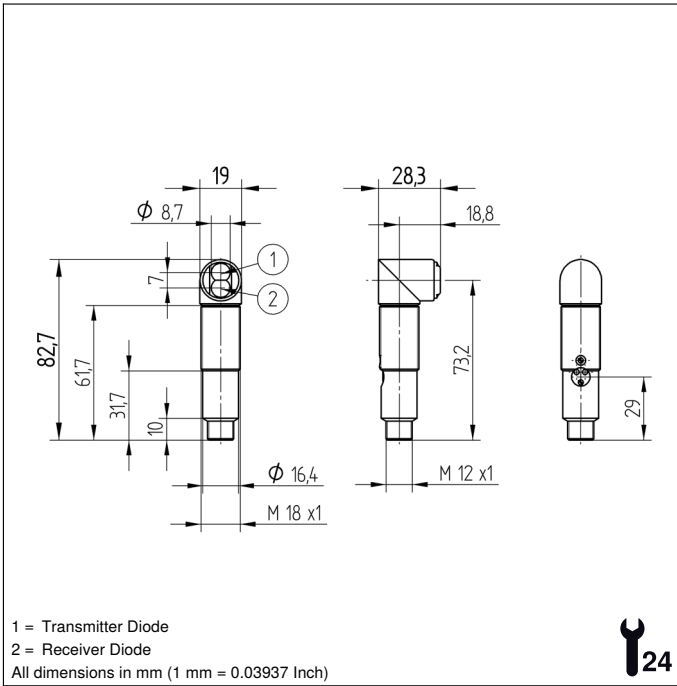
D18

05 = Switching Distance Adjuster
 30 = Switching Status/Contamination Warning
 68 = supply voltage indicator

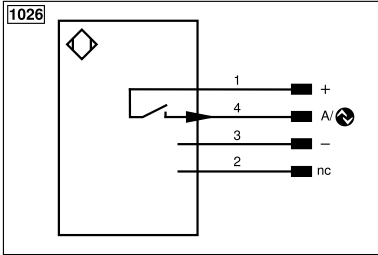

Legend			
+	Supply Voltage +	nc	Not connected
-	Supply Voltage 0 V	U	Test Input
~	Supply Voltage (AC Voltage)	Ū	Test Input inverted
A	Switching Output (NO)	W	Trigger Input
Ā	Switching Output (NC)	W-	Ground for the Trigger Input
V	Contamination/Error Output (NO)	O	Analog Output
ȳ	Contamination/Error Output (NC)	O-	Ground for the Analog Output
E	Input (analog or digital)	BZ	Block Discharge
T	Teach Input	Amv	Valve Output
Z	Time Delay (activation)	a	Valve Control Output +
S	Shielding	b	Valve Control Output 0 V
RxD	Interface Receive Path	SY	Synchronization
TxD	Interface Send Path	SY-	Ground for the Synchronization
RDY	Ready	E+	Receiver-Line
GND	Ground	S+	Emitter-Line
CL	Clock	±	Grounding
E/A	Output/Input programmable	SnR	Switching Distance Reduction
IO-Link	IO-Link	Rx+/-	Ethernet Receive Path
PoE	power over Ethernet	Tx+/-	Ethernet Send Path
IN	Safety Input	Bus	Interfaces-Bus A(+)/B(-)
OSSD	Safety Output	La	Emitted Light disengageable
Signal	Signal Output	Mag	Magnet activation
BI_D+/-	Ethernet Gigabit bidirect. data line (A-D)	RES	Input confirmation
ENo RS422	Encoder 0-pulse 0/0 (TTL)	EDM	Contact Monitoring
PT	Platinum measuring resistor	ENARs422	Encoder A/Ā (TTL)
			Encoder B/B̄ (TTL)
			Encoder A
			Encoder B
			Digital output MIN
			Digital output MAX
			Digital output OK
			Synchronization In
			Synchronization OUT
			Brightness output
			Maintenance
			Reserved
			Wire Colors according to DIN IEC 60757
			BK Black
			BN Brown
			RD Red
			OG Orange
			YE Yellow
			GN Green
			BU Blue
			VT Violet
			GY Grey
			WH White
			PK Pink
			GNYE Green/Yellow

Feasible reflector distance

Reflector type, mounting distance

RQ100BA	0,02...6 m	RR25_M	0,02...1,6 m
RE18040BA	0,02...3,3 m	RR25KP	0,02...1,4 m
RQ84BA	0,01...4,5 m	RR21_M	0,01...1,6 m
RR84BA	0,02...4,5 m	ZRAE02B01	0,02...3 m
RE9538BA	0,02...1,5 m	ZRME01B01	0,02...1,1 m
RE6151BM	0,01...4,5 m	ZRME03B01	0,02...2,8 m
RE6151BA	0,02...2,3 m	ZRMR02K01	0,02...1,1 m
RR50_A	0,02...4 m	ZRMS02_01	0,01...1,5 m
RE6040BA	0,02...4 m	RF505	0,06...1,6 m
RE8222BA	0,01...2 m	RF255	0,06...1,2 m
RR34_M	0,01...2,4 m	RF508	0,06...1,6 m
RE3220BM	0,01...1,6 m	RF258	0,06...1,2 m
RE6210BM	0,01...1,6 m	ZRDF_K01	0,06...4 m

