



- Compact M30 standard design with IP67 degree of protection and zoom lens
- Continuous mode or strobe mode synchronized with the camera
- Homogeneous illumination of small areas

The LSL spotlight has a built-in, lockable zoom lens that provides an exceptional range of visual field, working distance and brightness variability. The illumination can be operated in continuous mode or synchronized with the camera in overdrive strobe mode.

Technical Data

Optical Data	
Light Source	Infrared Light
Wavelength	850 nm
Risk Group (EN 62471)	2
Aperture angle	4...26 °
Infrared light output	1412 W/m ²
Measuring point distance	100 mm
Environmental conditions	
Temperature Range	-10...40 °C
Storage temperature	-20...60 °C
Atmospheric humidity	< 80%, non-condensing
Electrical Data	
Supply Voltage	21,6...26,4 V DC
Current consumption flash mode overdrive (operating voltage = 24 V)	552 mA
Current Consumption Continuous Mode (U _b = 24 V)	202 mA
Flash duration (max.)	10 ms
Duty cycle (max.)	< 0,2
Dimming	0...10 V ± 100...30%
Overdrive	yes
Rise time	4 μs
Fall time	25 μs
Input signal	PNP/NPN
Short Circuit and Overload Protection	yes
Reverse Polarity Protection	yes
Protection Class	III
Mechanical Data	
Housing Material	Aluminum, anodised
Housing Material	Glass
Housing Material	Plastic, PMMA
Optic Cover	Plastic, PMMA
Degree of Protection	IP67
Connection	M12 × 1; 5-pin

Connection Diagram No.

007

Complementary Products

Connection cables
ZSLG001 polarization filter
ZSLZ001 mounting adapter

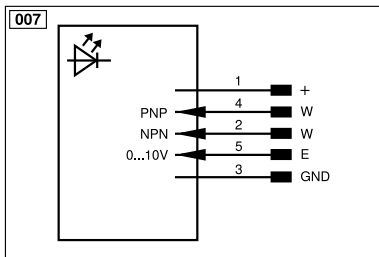
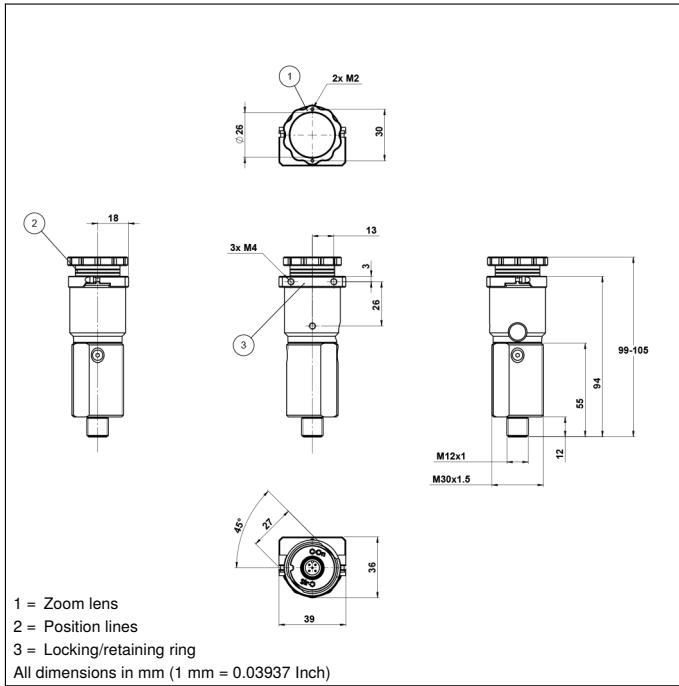

Legend			
+	Supply Voltage +	nc	Not connected
-	Supply Voltage 0 V	U	Test Input
~	Supply Voltage (AC Voltage)	Ü	Test Input inverted
A	Switching Output (NO)	W	Trigger Input
Ā	Switching Output (NC)	W-	Ground for the Trigger Input
V	Contamination/Error Output (NO)	O	Analog Output
ȳ	Contamination/Error Output (NC)	O-	Ground for the Analog Output
E	Input (analog or digital)	BZ	Block Discharge
T	Teach Input	Amv	Valve Output
Z	Time Delay (activation)	a	Valve Control Output +
S	Shielding	b	Valve Control Output 0 V
RxD	Interface Receive Path	SY	Synchronization
TxD	Interface Send Path	SY-	Ground for the Synchronization
RDY	Ready	E+	Receiver-Line
GND	Ground	S+	Emitter-Line
CL	Clock	±	Grounding
E/A	Output/Input programmable	SnR	Switching Distance Reduction
IO-Link		Rx+/-	Ethernet Receive Path
PoE	Power over Ethernet	Tx+/-	Ethernet Send Path
IN	Safety Input	Bus	Interfaces-Bus A(+)/B(-)
OSSD	Safety Output	La	Emitted Light disengageable
Signal	Signal Output	Mag	Magnet activation
BI_D+/-	Ethernet Gigabit bidirect. data line (A-D)	RES	Input confirmation
ENo RS422	Encoder 0-pulse 0/0 (TTL)	EDM	Contactor Monitoring
PT	Platinum measuring resistor	ENARs422	Encoder A/Ā (TTL)
			Encoder B/B̄ (TTL)
			Encoder A
			Encoder B
			Digital output MIN
			Digital output MAX
			Digital output OK
			Synchronization In
			Synchronization OUT
			Brightness output
			Maintenance
			Reserved
			Wire Colors according to DIN IEC 60757
			BK Black
			BN Brown
			RD Red
			OG Orange
			YE Yellow
			GN Green
			BU Blue
			VT Violet
			GY Grey
			WH White
			PK Pink
			GNYE Green/Yellow

