

Contrast Sensor

P1PW005

Part Number



- Color mode
- Innovative display unit for simple diagnosis
- Intuitive operating concept
- Teach-in key and external teach-in
- Very high contrast resolution

These contrast sensors work with a white light LED emitter and an RGB receiver. They reliably detect all color and brightness combinations between the contrast marking and the background. The intuitive operating concept with the LED bar graph display and the well-conceived functions simplify initial start-up and make the sensors suitable for flexible use. The contrast sensors can also be parameterized via IO-Link. Extensive condition monitoring functions are also available for predictive maintenance and trouble-free operation.



Technical Data

Optical Data	
Working Range	30...40 mm
Working Distance	35 mm
Resolution (Gray Scale)	100
Switching Hysteresis	< 1 %
Light Source	White Light
Wavelength	400...700 nm
Service Life (T = +25 °C)	100000 h
Max. Ambient Light	10000 Lux
Light Spot Diameter	1,1 × 3,5 mm

Electrical Data	
Supply Voltage	10...30 V
Supply Voltage with IO-Link	18...30 V
Current Consumption (U _b = 24 V)	< 50 mA
Switching Frequency	50 kHz
Response Time	13 μs
Jitter	5 μs
Temperature Drift	< 6 %
Temperature Range	-25...60 °C
Switching Output Voltage Drop	1,5 V
Switching Output/Switching Current	100 mA
Short Circuit Protection	yes
Reverse Polarity Protection	yes
Lockable	yes
Mode of operation	Color
Interface	IO-Link V1.1
IO-Link transmission speed	COM2
Protection Class	III
IO-Link Version	1.1

Mechanical Data	
Setting Method	Teach-In
Housing Material	Plastic, ABS
Optic Cover	Plastic, PMMA
Degree of Protection	IP67
Connection	M12 × 1; 5-pin

Safety-relevant Data	
MTTFd (EN ISO 13849-1)	719,27 a
PNP NC, PNP NO	●
External teach-in input	●
Connection Diagram No.	317
Control Panel No.	X9
Suitable Connection Equipment No.	2 35
Suitable Mounting Technology No.	380

Complementary Products

IO-Link Master Software

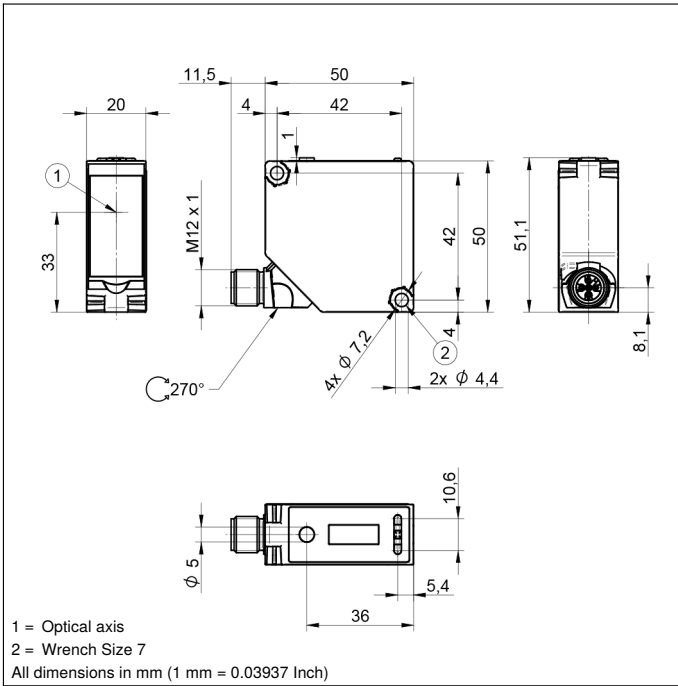

Ctrl. Panel

X9

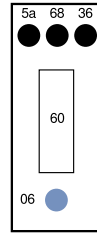

- 06 = Teach Button
- 36 = Mode Indicator
- 5a = Switching Status Indicator, A1
- 60 = display
- 68 = Power LED

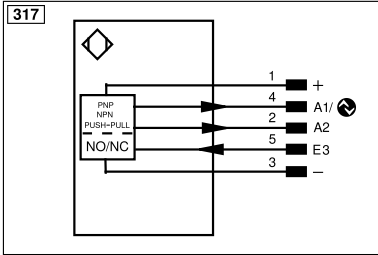

Legend					
+	Supply Voltage +	PT	Platinum measuring resistor	ENARs422	Encoder A/Ā (TTL)
-	Supply Voltage 0 V	nc	Not connected	ENBRs422	Encoder B/B̄ (TTL)
~	Supply Voltage (AC Voltage)	U	Test Input	ENa	Encoder A
A	Switching Output (NO)	Ū	Test Input inverted	ENb	Encoder B
Ā	Switching Output (NC)	W	Trigger Input	AMIN	Digital output MIN
V	Contamination/Error Output (NO)	W-	Ground for the Trigger Input	AMAX	Digital output MAX
Ū	Contamination/Error Output (NC)	O	Analog Output	Aok	Digital output OK
E	Input (analog or digital)	O-	Ground for the Analog Output	SY In	Synchronization In
T	Teach Input	BZ	Block Discharge	SY OUT	Synchronization OUT
R	Reset input	Amv	Valve Output	Out	Brightness output
Z	Time Delay (activation)	a	Valve Control Output +	M	Maintenance
S	Shielding	b	Valve Control Output 0 V	rsv	Reserved
RxD	Interface Receive Path	SY	Synchronization	Wire Colors according to DIN IEC 60757	
TxD	Interface Send Path	SY-	Ground for the Synchronization	BK	Black
RDY	Ready	E+	Receiver-Line	BN	Brown
GND	Ground	S+	Emitter-Line	RD	Red
CL	Clock	≡	Grounding	OG	Orange
E/A	Output/Input programmable	SnR	Switching Distance Reduction	YE	Yellow
	IO-Link	Rx+/-	Ethernet Receive Path	GN	Green
PoE	Power over Ethernet	Tx+/-	Ethernet Send Path	BU	Blue
IN	Safety Input	Bus	Interfaces-Bus A(+)/B(-)	VT	Violet
QSSD	Safety Output	La	Emitted Light disengageable	GY	Grey
Signal	Signal Output	Mag	Magnet activation	WH	White
Bl_D+/-	Ethernet Gigabit bidirect. data line (A-D)	RES	Input confirmation	PK	Pink
ENo RS422	Encoder 0-pulse 0/0 (TTL)	EDM	Contacting Monitoring	GNYE	Green/Yellow

Ideal Working Distance

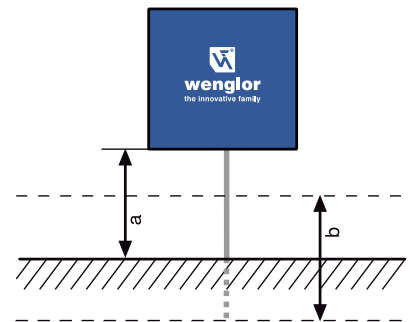

a = working distance
 b = Working Range

