

Operating Instructions

U2GT004

Distance Sensor



EN



Table of Contents

1	General	4
1.1	Information Concerning these Instructions	4
1.2	Explanation of Symbols	4
1.3	Limitation of Liability	5
1.4	Copyrights	6
2	For Your Safety	7
2.1	Use for Intended Purpose	7
2.2	Use for Other than the Intended Purpose	7
2.3	Personnel Qualifications	8
2.4	Modification of Products	8
2.5	General Safety Precautions	8
2.6	Approvals and Protection Class	8
3	Technical Data	9
3.1	General Data	9
3.2	Default Settings	10
3.3	Warm-up Phase	10
3.4	Mode-Dependent Data	10
3.5	Sonic Cone Diagrams	11
3.6	Housing Dimensions	12
3.7	Layout	12
3.8	Complementary Products	13
3.9	Scope of Delivery	13
4	Transport and Storage	14
4.1	Transport	14
4.2	Storage	14
5	Installation and Electrical Connection	15
5.1	Installation	15
5.2	Electrical Connection	16
5.3	Diagnosis	17
6	Settings	18
6.1	Setting via IO-Link and wTeach2	18
6.1.1	Foreground Teach-In	18
6.1.2	Background Teach-In	18
6.1.3	Window teach-in	19
6.1.4	Through-Beam Sensor Operating Mode	19
6.1.5	Additional Functions and Settings	20
6.2	Pin Functions	22
6.2.1	Input Functions	22
6.2.2	Output Functions	22
6.3	Condition Monitoring Functions	23
6.3.1	Status Message Function	23
6.3.2	Error Output Function	23
6.3.3	Simulation Functions	24
6.4	Condition Monitoring/Process Data	24
6.4.1	Process Data In	25
6.4.2	Process Data Out	25
6.4.3	Events	25

7 wTeach2 Configuration Software..... 26

8 Maintenance Instructions 27

9 Proper Disposal 28

10 Declarations of Conformity..... 29

1 General

1.1 Information Concerning these Instructions

- These instructions make it possible to use the product safely and efficiently.
- These instructions are an integral part of the product and must be kept on hand for the entire duration of its service life.
- Local accident prevention regulations and national work safety regulations must be complied with as well.
- The product is subject to further technical development, and thus the information contained in these operating instructions may also be subject to change. The current version can be found at www.wenglor.com in the product's separate download area.



INFORMATION

The operating instructions must be read carefully before using the product and must be kept on hand for later reference.

1.2 Explanation of Symbols

- Safety precautions and warnings are emphasized by means of symbols and signal words.
- Safe use of the product is only possible if these safety precautions and warnings are adhered to.

The safety precautions and warnings are laid out in accordance with the following principle:

SIGNAL WORD

Type and source of danger!

Possible consequences in the event that the hazard is disregarded.

→ Measures for averting the hazard.

The meanings of the signal words, as well as the scope of the associated hazards, are listed below:



DANGER

This signal word indicates a hazard with a high degree of risk which, if not avoided, results in death or severe injury.



WARNING

This signal word indicates a hazard with a medium degree of risk which, if not avoided, may result in death or severe injury.



CAUTION

This signal word indicates a hazard with a low degree of risk which, if not avoided, may result in minor or moderate injury.



NOTICE

This signal word draws attention to a potentially hazardous situation which, if not avoided, may result in property damage.



INFORMATION

Information draws attention to useful tips and suggestions, as well as information on efficient, error-free use.

1.3 Limitation of Liability

- The product has been developed in consideration of the current state-of-the-art technology, as well as applicable standards and guidelines. Subject to change without notice.
- A valid declaration of conformity can be accessed at www.wenglor.com in the product's separate download area.
- wenglor sensoric elektronische Geräte GmbH (hereinafter referred to as "wenglor") excludes all liability in the event of:
 - Non-compliance with the instructions
 - Use of the product for purposes other than those intended.
 - Use by untrained personnel.
 - Use of unapproved spare parts.
 - Unapproved modification of products.
- These operating instructions do not include any guarantees from wenglor with regard to the described procedures or specific product characteristics.
- wenglor assumes no liability for printing errors or other inaccuracies contained in these operating instructions unless wenglor was verifiably aware of such errors at the point in time at which the operating instructions were prepared.

1.4 Copyrights

- The contents of these instructions are protected by copyright law.
- All rights are reserved by wenglor.
- Commercial reproduction or any other commercial use of the provided content and information, in particular graphics and images, is not permitted without previous written consent from wenglor.

2 For Your Safety

2.1 Use for Intended Purpose

Ultrasonic sensors emit pulsed ultrasonic waves at a certain frequency using air as a transmitting medium. Parameters can be taught into the sensors shown here via an input or IO-Link. The output is switched when the preselected switching point is reached. With some variants, the measured values can be output as an analog value. In addition, the measured value can be read out via IO-Link 1.1. The sensors can be used in both reflex mode and through-beam mode.

This product can be used in the following industry sectors:

- Special-purpose mechanical engineering
- Heavy mechanical engineering
- Logistics
- Automotive industry
- Food industry
- Packaging industry
- Pharmaceuticals industry
- Plastics industry
- Woodworking industry
- Clothing industry
- Printing industry
- Consumer goods industry
- Paper industry
- Electronics industry
- Glass industry
- Steel industry
- Aviation industry
- Chemicals industry
- Alternative energies
- Raw materials extraction
- Construction industry
- Agriculture industry

2.2 Use for Other than the Intended Purpose

- Not a safety component in accordance with 2006/42/EC (Machinery Directive).
- The product is not suitable for use in potentially explosive atmospheres.
- The product may be used only with accessories supplied or approved by wenglor, or in combination with approved products. A list of approved accessories and combination products can be found at www.wenglor.com on the product detail page.



⚠ DANGER

Risk of personal injury or property damage in case of use for other than the intended purpose!

Use for other than the intended purpose may lead to hazardous situations.

- Observe instructions regarding use for intended purpose.

2.3 Personnel Qualifications

- Suitable technical training is a prerequisite.
- In-house electronics training is required.
- Trained personnel who use the product must have (permanent) access to the operating instructions.



DANGER

Risk of personal injury or property damage in case of incorrect initial start-up and maintenance!

Personal injury and damage to equipment may occur.

→ Adequate training and qualification of personnel

2.4 Modification of Products



DANGER

Risk of personal injury or property damage if the product is modified!

Personal injury and damage to equipment may occur. Noncompliance may result in loss of the CE mark and voiding of the warranty.

→ Modification of the product is not permitted

2.5 General Safety Precautions



INFORMATION

These instructions are an integral part of the product and must be kept on hand for the entire duration of its service life.

In the event of possible changes, the current version of the operating instructions can be found at www.wenglor.com in the product's separate download area.

Read the operating instructions carefully before using the product.

Protect the sensor against contamination and mechanical influences.

2.6 Approvals and Protection Class

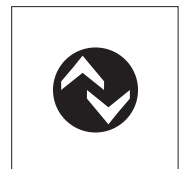
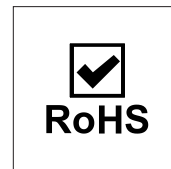
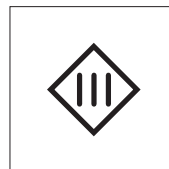
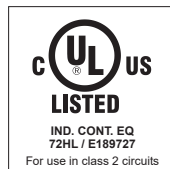

3 Technical Data

3.1 General Data

Technical Data	
Ultrasound Data	
Working range, reflex sensor	150 ... 1300 mm
Working range, through-beam sensor	1 ... 2600 mm
Setting Range	150 ... 1300 mm
Reproducibility maximum	8 mm
Linearity Deviation	8 mm
Resolution	1 mm
Ultrasonic Frequency	205 kHz
Opening Angle	< 13 °
Service Life (T = +25 °C)	100000 h
Switching Hysteresis	2 % *
Electrical Data	
Supply Voltage	18 ... 30 V DC
Current Consumption (Ub = 24 V)	< 35 mA
Switching frequency, reflex sensor	10 Hz
Switching frequency, through-beam sensor	10 Hz
Response time, reflex sensor	50 ms
Response time, through-beam sensor	50 ms
Temperature Drift	< 10 %
Temperature Range	-30 ... 60 °C
Number of Switching Outputs	1
Switching Output Voltage Drop	< 2.5 V
Switching Output/Switching Current	100 mA
Short Circuit Protection	yes
Reverse Polarity and Overload Protection	yes
Interface	IO-Link V1.1 Smart Sensor Profile
Data Storage	no
Protection Class	III
Mechanical Data	
Setting Method	IO-Link Teach-In
Housing Material	Stainless steel, V4A (1.4404 / 316L)
Sensing face	Stainless steel, V4A
Degree of Protection	IP68/IP69K
Connection	M12 × 1; 4/5-pin
Output Function	
Error Output	yes
PNP NO	-
Analog Output	yes
Technical Safety Data	
MTTFd (EN ISO 13849-1)	1192.59 a

* Referring to the switching distance, at least 2 mm.

3.2 Default Settings

Technical Data	
Temperatur Mode	internal
A1 Pin Function	Error output
A1 Teach Mode	Foreground
A1 PNP/NPN	PNP
A1 NO/NC	NO
A1 Switching Point	1.300 mm
A1 Additional hysteresis	0
A2 Pin Function	Analog output (4...20 mA)
A2 Teach Mode	Foreground
A2 4 mA	150 mm
A2 20 mA	1300 mm
E3 Function	Teach input

3.3 Warm-up Phase

The warm-up phase lasts roughly 30 minutes. At the beginning of the warm-up phase, linearity deviation and reproducibility may deviate from the specified values. During the warm-up phase, the values improve in the form of an exponential function until the values in the technical data are reached. The switch-on drift during this time is shown in the following diagram.

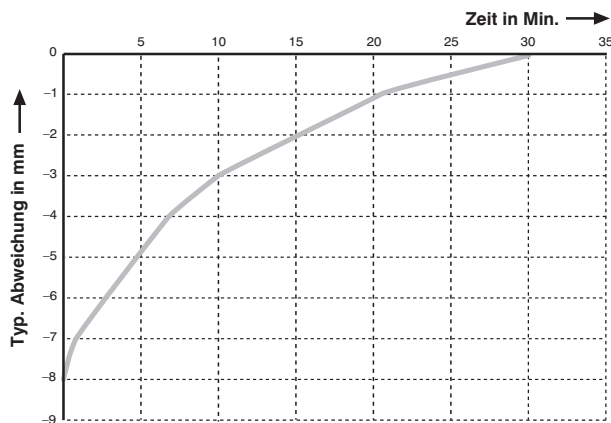

3.4 Mode-Dependent Data

Some technical data depend on the mode set. Depending on the setting, the following data are obtained:

Reflex and Through-Beam Mode

Filter value	Switching frequency in Hz	Response time in ms
0	10.0	50
1	7.5	67
2	6.0	83
3	5.0	100
4	4.3	117
5	3.8	133
6	3.3	150
7	3.0	166
8	2.7	183

Filter value	Switching frequency in Hz	Response time in ms
9	2.5	200
10	2.3	216
11	2.1	233
12	2.0	250
13	1.9	266
14	1.8	283
15	1.7	300
16*	1.6	316
17*	1.3	383
18*	1.11	450
19*	1.07	467
20*	1.07	467

* The specified switching frequency and response time correspond to the maximum duration including the interference filter. A detailed description of the filter function can be found in section Additional Functions and Settings.

3.5 Sonic Cone Diagrams

Measurement of the sonic cone on a 100 × 100 mm plate

Characteristic curves show the position of the center or the front edge of the measured object (100 × 100 mm plate) at the time of switching.

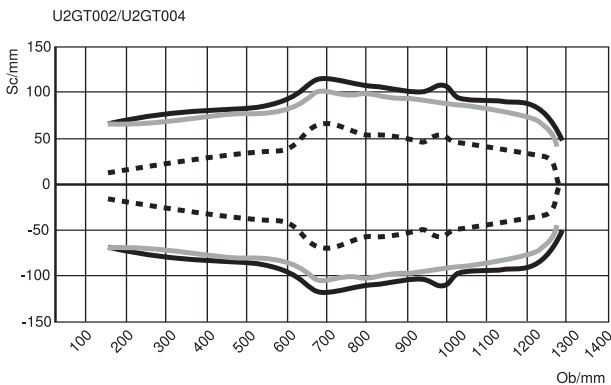

Measurement of the sonic cone on a rod with a diameter of 25 mm

Characteristic curves show the position of the center or the front edge of the measured object (Ø 25 mm rod) at the time of switching.

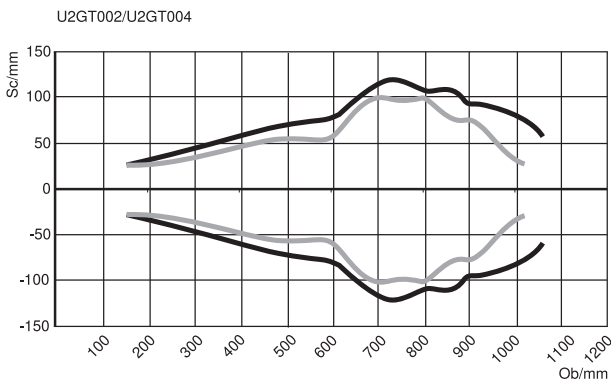

Ob = object

Sc = sonic cone

— Standard sonic cone (center of the measured object)

- Extra-narrow sonic cone (center of the measured object)
- Standard sonic cone (front edge of the measured object)



INFORMATION

Please note that using multiple ultrasonic sensors can cause reciprocal influence.

3.6 Housing Dimensions

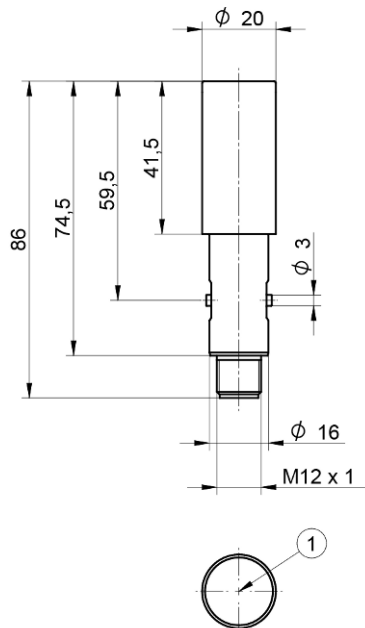

① = transducer

Dimensions specified in mm (1 mm = 0.03937 Inch)

3.7 Layout

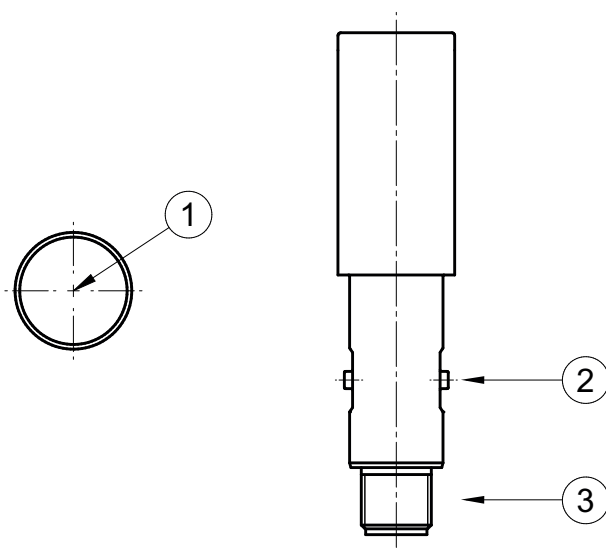

① = transducer

② = bayonet fastening

③ = connector plug

3.8 Complementary Products

wenglor offers you the right connection and mounting technology as well as other accessories for your product. You can find this at www.wenglor.com on the product details page at the bottom.

3.9 Scope of Delivery

- Sensor
- Safety precaution

4 Transport and Storage

4.1 Transport

Upon receipt of shipment, the goods must be inspected for damage in transit. In the case of damage, conditionally accept the package and notify the manufacturer of the damage. Then return the device, making reference to damage in transit.

4.2 Storage

The following points must be taken into consideration with regard to storage:

- Do not store the product outdoors.
- Store the product in a dry, dust-free place.
- Protect the product against mechanical impacts.
- Protect the product against exposure to direct sunlight.



NOTICE

Risk of property damage in case of improper storage!

The product may be damaged.

→ Storage instructions must be complied with.

5 Installation and Electrical Connection

5.1 Installation

The hygienic fasteners provided by wenglor must be used for mounting the sensor to prevent vibration transmission to the surroundings. Ensure that the mounting clamps and brackets are positioned behind the seal. In contrast to the optical sensors, the U2GT sensor must not be clamped directly in the mounting device. The use of other mounting technology can lead to malfunction of the sensor, for which wenglor sensoric elektronische Geräte GmbH assumes no liability. The following also applies:

- Protect the product from contamination during installation.
- Observe all applicable electrical and mechanical regulations, standards and safety rules.
- Protect the product against mechanical influences.
- Make sure that the sensor is mounted in a mechanically secure fashion.
- Specified torque values must be complied with (see section Technical Data [► 9]).
- If the object has smooth surfaces, the angle between the axis of the sound waves and the surface of the object should be $90^\circ \pm 3^\circ$. The angle can be considerably larger in the case of rough object surfaces.
- The active surface of the sensor may not contact any other machine parts.



INFORMATION

Observe the blind spot.

In the area between the sensor's active surface and the beginning of its working range, correct functioning of the sensor is not assured. No objects may be located in this area.



NOTICE

Risk of property damage in case of improper installation!

The product may be damaged!

→ Comply with installation instructions.



CAUTION

Risk of personal injury or property damage during installation!

Personal injury and damage to the product may occur.

→ Ensure a safe installation environment.

5.2 Electrical Connection

- Wire the sensor in accordance with the connection diagram.
- Switch on the supply voltage (see section Technical Data [► 9]).
- If not using IO-Link, connect the sensor to 10...30 V DC.



DANGER

Risk of personal injury or property damage due to electric current.

Voltage-conducting parts may cause personal injury or damage to equipment.

→ The electric device may be connected by appropriately qualified personnel only.

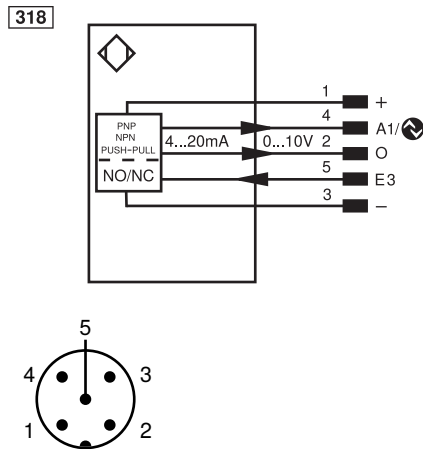

1	Brown	2	White
3	Blue	4	Black
5	Gray		

Legend

+	Supply Voltage +
-	Supply Voltage 0 V
~	Supply Voltage (AC Voltage)
A	Switching Output (NO)
\bar{A}	Switching Output (NC)
V	Contamination/Error Output (NO)
\bar{V}	Contamination/Error Output (NC)
E	Input (analog or digital)
T	Teach Input
Z	Time Delay (activation)
s	Shielding
RxD	Interface Receive Path
TxD	Interface Send Path
RDY	Ready
GND	Ground
CL	Clock
E/A	Output/Input programmable
	IO-Link
PoE	Power over Ethernet
IN	Safety Input
SSD	Safety Output
Signal	Signal Output
BI_D+/-	Ethernet Gigabit bidirect. data line (A-D)
EN0 RS422	Encoder 0-pulse 0-0 (TTL)

PT	Platinum measuring resistor
nc	not connected
U	Test Input
\bar{U}	Test Input inverted
W	Trigger Input
W-	Ground for the Trigger Input
O	Analog Output
O-	Ground for the Analog Output
BZ	Block Discharge
AWV	Valve Output
a	Valve Control Output +
b	Valve Control Output 0 V
SY	Synchronization
SY-	Ground for the Synchronization
E+	Receiver-Line
S+	Emitter-Line
\oplus	Grounding
SnR	Switching Distance Reduction
Rx+/-	Ethernet Receive Path
Tx+/-	Ethernet Send Path
Bus	Interfaces-Bus A(+)/B(-)
La	Emitted Light disengageable
Mag	Magnet activation
RES	Input confirmation
EDM	Contact Monitoring

ENAR5422	Encoder A/A (TTL)
ENBR5422	Encoder B/B (TTL)
ENA	Encoder A
ENB	Encoder B
AMIN	Digital output MIN
AMAX	Digital output MAX
AOK	Digital output OK
SY In	Synchronization In
SY OUT	Synchronization OUT
OLT	Brightness output
M	Maintenance
rsv	reserved
Wire Colors according to IEC 60757	
BK	Black
BN	Brown
RD	Red
OG	Orange
YE	Yellow
GN	Green
BU	Blue
VT	Violet
GY	Grey
WH	White
PK	Pink
GNYE	Green/Yellow

5.3 Diagnosis

	Possible cause	Elimination
Error and warning	No signal	<ul style="list-style-type: none"> • Adjust sensor object distance • Minimize environmental influences (air circulation, ultrasonic sources) • Check installation
	Object too close	<ul style="list-style-type: none"> • Increase sensor object distance
	Object too far	<ul style="list-style-type: none"> • Decrease sensor object distance
	Short circuit	<ul style="list-style-type: none"> • Check the electrical wiring and eliminate the short circuit
	Undervoltage	<ul style="list-style-type: none"> • Check the sensor's voltage supply
	Device error	<ul style="list-style-type: none"> • Disconnect the sensor from the supply voltage and restart it • Replace the sensor

Via IO-Link, it is possible to identify the respective causes precisely by means of condition monitoring.



NOTICE

Required Action in Case of Fault:

1. Shut down the machine.
2. Analyze and eliminate the cause of error with the aid of the diagnostics information.
3. If the error cannot be eliminated, please contact wenglor's support department.
4. Do not operate in case of indeterminate malfunctioning.
5. The machine must be shut down if the error cannot be definitively explained or properly eliminated.



DANGER

Risk of personal injury or property damage in case of non-compliance!

The system's safety function is disabled. Personal injury and damage to equipment may occur.

→ Required action as specified in case of fault.

6 Settings

The sensor can be set via external teach-in, IO-Link and wTeach2. The different setting options are outlined below.

6.1 Setting via IO-Link and wTeach2

The sensors can exchange parameters and process data via IO-Link. The parameters can be used to make many additional settings on the device. The process data transmit cyclical data and condition monitoring.

To this end, the sensor is connected to a suitable IO-Link master (see product detail page/complementary products). The interface protocol and the IODD can be found at www.wenglor.com in the download area for the respective product.

For information on installing and connecting the wTeach2 software and its structure, as well as information on the general functions, see the wTeach2 operating instructions. They can be found online in the download area at www.wenglor.com under order number DNNF005.

6.1.1 Foreground Teach-In

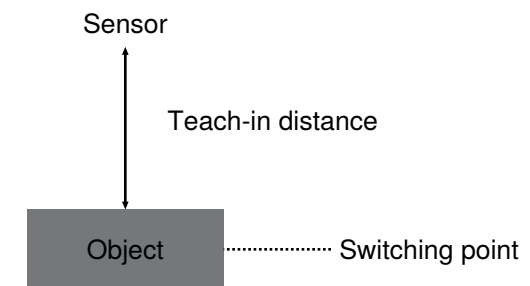

1. Install the sensor in accordance with the installation instructions.
2. Align the sensor with the foreground.
3. Configure or teach-in the switching output / the switching output function via IO-Link.
4. The sensor is switched as soon as an object is located between the foreground and the sensor.



INFORMATION

If there's no object within the measuring range, switching distance is set to the end of the setting range.

6.1.2 Background Teach-In

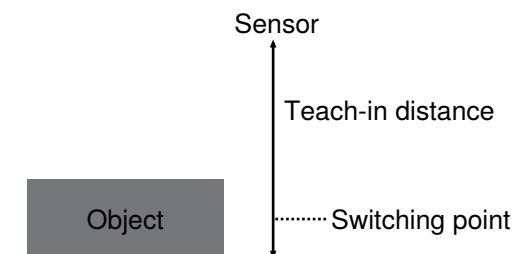

1. Install the sensor in accordance with the installation instructions.
2. Align the sensor to the background.
3. Configure or teach-in the switching output / the switching output function via IO-Link.

- The sensor is switched as soon as an object is located between the background and the sensor.



INFORMATION

If there's no object within the measuring range, switching distance is set to the end of the setting range.

6.1.3 Window teach-in

In addition to foreground teach-in (default setting), there is also a window teach-in option for the switching output:

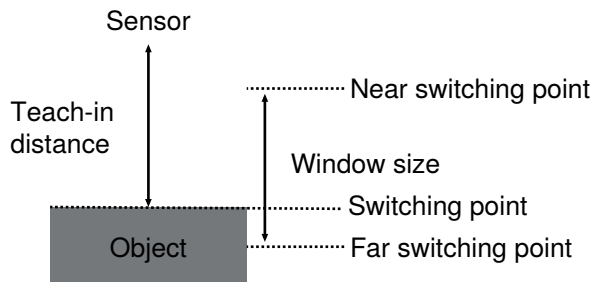

- Enter or teach in the far switching point.
- Enter or teach in the near switching point.
- The sensor is switched when an object is located between the two switching points.



INFORMATION

The far switching point must be greater than the near switching point.

6.1.4 Through-Beam Sensor Operating Mode

In addition to the reflex mode (default setting), a through-beam operating mode is also available. Two sensors are required to this end.

- Set up one sensor as an emitter.
- Set up another sensor as a receiver.
- If the receiver is operated as a normally closed contact, it is switched when an object is located between the emitter and the receiver.



INFORMATION

- The sonic cone setting on the receiver determines the sensitivity of the through-beam sensor:
- The maximum range can be achieved with the standard sonic cone.



INFORMATION

Sensors in reflex and through-beam mode must not be combined!

Differentiation between one and two layers of thin material such as paper or foil is possible in the through-beam operating mode.

1. Position the emitter and the receiver a short distance from each other.
2. Adjust the distance between the emitter and the receiver so that the receiver continues to switch for one layer but not for two.

6.1.5 Additional Functions and Settings

Function	Possible Settings	Default																																																
Filter	The selected filter affects the response time (see General Data) and the number of distance values that will be evaluated.	0																																																
	<table border="1"> <thead> <tr> <th>Filter</th> <th>Description</th> </tr> </thead> <tbody> <tr> <td>0-15</td> <td>Median filter Median filter from the specified number of measured values. If the signal is missing or invalid, an error is issued. This filter can provide additional smoothing of the signal in applications with objects with a homogeneous surface in a stable environment.</td> </tr> <tr> <td>0</td> <td>Median filter of 3 measured values</td> </tr> <tr> <td>1</td> <td>Median filter of 4 measured values</td> </tr> <tr> <td>2</td> <td>Median filter of 5 measured values</td> </tr> <tr> <td>3</td> <td>Median filter of 6 measured values</td> </tr> <tr> <td>4</td> <td>Median filter of 7 measured values</td> </tr> <tr> <td>5</td> <td>Median filter of 8 measured values</td> </tr> <tr> <td>6</td> <td>Median filter of 9 measured values</td> </tr> <tr> <td>7</td> <td>Median filter of 10 measured values</td> </tr> <tr> <td>8</td> <td>Median filter of 11 measured values</td> </tr> <tr> <td>9</td> <td>Median filter of 12 measured values</td> </tr> <tr> <td>10</td> <td>Median filter of 13 measured values</td> </tr> <tr> <td>11</td> <td>Median filter of 14 measured values</td> </tr> <tr> <td>12</td> <td>Median filter of 15 measured values</td> </tr> <tr> <td>13</td> <td>Median filter of 16 measured values</td> </tr> <tr> <td>14</td> <td>Median filter of 17 measured values</td> </tr> <tr> <td>15</td> <td>Median filter of 18 measured values</td> </tr> <tr> <td>16-20</td> <td>Special filter from a defined number of measured values with bridging of missing measured values. The additional interference filter can be used to increase measurement reliability in the case of brief interferences in the measured section. Waves, air vortexes, sound-absorbing areas or bulk solids generate temporarily invalid signals that can lead to incorrect measurements. A higher filter level allows the interfering signals to be ignored for a defined period. If the distance changes continuously, the response time remains unchanged when the filter is activated.</td> </tr> <tr> <td>16</td> <td>Filter of 19 measured values and bridging of 4 missing measured values (64 ms)</td> </tr> <tr> <td>17</td> <td>Filter of 23 measured values and bridging of 7 missing measured values (112 ms)</td> </tr> <tr> <td>18</td> <td>Filter of 27 measured values and bridging of 15 missing measured values (240 ms)</td> </tr> <tr> <td>19</td> <td>Filter of 28 measured values and bridging of 31 missing measured values (469 ms)</td> </tr> <tr> <td>20</td> <td>Filter of 28 measured values and bridging of 62 missing measured values (992 ms)</td> </tr> </tbody> </table>	Filter	Description	0-15	Median filter Median filter from the specified number of measured values. If the signal is missing or invalid, an error is issued. This filter can provide additional smoothing of the signal in applications with objects with a homogeneous surface in a stable environment.	0	Median filter of 3 measured values	1	Median filter of 4 measured values	2	Median filter of 5 measured values	3	Median filter of 6 measured values	4	Median filter of 7 measured values	5	Median filter of 8 measured values	6	Median filter of 9 measured values	7	Median filter of 10 measured values	8	Median filter of 11 measured values	9	Median filter of 12 measured values	10	Median filter of 13 measured values	11	Median filter of 14 measured values	12	Median filter of 15 measured values	13	Median filter of 16 measured values	14	Median filter of 17 measured values	15	Median filter of 18 measured values	16-20	Special filter from a defined number of measured values with bridging of missing measured values. The additional interference filter can be used to increase measurement reliability in the case of brief interferences in the measured section. Waves, air vortexes, sound-absorbing areas or bulk solids generate temporarily invalid signals that can lead to incorrect measurements. A higher filter level allows the interfering signals to be ignored for a defined period. If the distance changes continuously, the response time remains unchanged when the filter is activated.	16	Filter of 19 measured values and bridging of 4 missing measured values (64 ms)	17	Filter of 23 measured values and bridging of 7 missing measured values (112 ms)	18	Filter of 27 measured values and bridging of 15 missing measured values (240 ms)	19	Filter of 28 measured values and bridging of 31 missing measured values (469 ms)	20	Filter of 28 measured values and bridging of 62 missing measured values (992 ms)	
Filter	Description																																																	
0-15	Median filter Median filter from the specified number of measured values. If the signal is missing or invalid, an error is issued. This filter can provide additional smoothing of the signal in applications with objects with a homogeneous surface in a stable environment.																																																	
0	Median filter of 3 measured values																																																	
1	Median filter of 4 measured values																																																	
2	Median filter of 5 measured values																																																	
3	Median filter of 6 measured values																																																	
4	Median filter of 7 measured values																																																	
5	Median filter of 8 measured values																																																	
6	Median filter of 9 measured values																																																	
7	Median filter of 10 measured values																																																	
8	Median filter of 11 measured values																																																	
9	Median filter of 12 measured values																																																	
10	Median filter of 13 measured values																																																	
11	Median filter of 14 measured values																																																	
12	Median filter of 15 measured values																																																	
13	Median filter of 16 measured values																																																	
14	Median filter of 17 measured values																																																	
15	Median filter of 18 measured values																																																	
16-20	Special filter from a defined number of measured values with bridging of missing measured values. The additional interference filter can be used to increase measurement reliability in the case of brief interferences in the measured section. Waves, air vortexes, sound-absorbing areas or bulk solids generate temporarily invalid signals that can lead to incorrect measurements. A higher filter level allows the interfering signals to be ignored for a defined period. If the distance changes continuously, the response time remains unchanged when the filter is activated.																																																	
16	Filter of 19 measured values and bridging of 4 missing measured values (64 ms)																																																	
17	Filter of 23 measured values and bridging of 7 missing measured values (112 ms)																																																	
18	Filter of 27 measured values and bridging of 15 missing measured values (240 ms)																																																	
19	Filter of 28 measured values and bridging of 31 missing measured values (469 ms)																																																	
20	Filter of 28 measured values and bridging of 62 missing measured values (992 ms)																																																	
	NOTE!																																																	

Function	Possible Settings	Default
	The technical data resulting from the various modes are specified in General Data.	
Transmission signal	<p>The transmit signal of the sensor can be switched off. This allows the sensor to be deactivated when not in use and, if necessary, interference can be avoided.</p> <p>On Transmit signal is on.</p> <p>Off Transmit signal is off. No measurements are taken. The switching behavior is identical to when no signal is received in reflective operation or as a through-beam sensor.</p>	On
Sonic cone	<p>This setting can be used to adjust the shape and range of the sonic cone. The diagrams for the individual sonic cones on standardized objects can be found in Sonic cone diagrams. Narrow cones can be used to block out constant disturbances in the measuring section (e.g. tank walls).</p> <p>Standard</p> <p>Narrow</p> <p>Extra narrow</p>	Standard
Measured value unit (process data type)	<p>The measured distance can be read out in millimeters or inches.</p> <p>Millimeter Read-out of distance values in mm for internal temperature compensation or external temperature compensation via the parameters</p> <p>Inch Read-out of distance values in 1/10 inch for internal temperature compensation or external temperature compensation via the parameters</p> <p>Millimeter (with external temperature) Output of distance values in mm and input of external temperature via Process Data Out</p> <p>Inch (with external temperature) Output of distance values in 1/10 inch and input of external temperature via Process Data Out</p>	Millimeter
Temperature mode	<p>The sensor has internal temperature compensation. Alternatively, the temperature can be measured externally and sent to the sensor as a process or parameter.</p> <p>Internal Sensor operates with internal temperature compensation.</p> <p>External Sensor works with external temperature compensation and uses the transmitted process or parameters (see section Condition monitoring/Process data). Whether process or parameter data is to be used is specified via the setting under Measured value unit > Process data type.</p>	Internal
External Temperature	<p>Temperature values can be transmitted to the sensor at a resolution of 1 °C for temperature compensation. Parameter is used if the external temperature compensation is to work via the parameters.</p> <p>–30...+60 °C</p> <p>NOTE! Regular update of external temperature data</p>	23 °C

Function	Possible Settings	Default
	is recommended to prevent temperature jumps and resulting jumps in the measurement result. If no temperature value is transmitted when the sensor is started up in the external temperature mode, the standard value of 23°C is used.	

6.2 Pin Functions

The most important pin functions are shown below.

Pin		Default
A1	<p>Switching output Switching point SSC1 is assigned to the switching output.</p> <p>Error output The error output switches if one of the assigned errors occurs; see table Status messages [► 23].</p> <p>Deactivated The pin is deactivated.</p>	Error output
O	<p>Analog output The analog output can be configured as a current or voltage output. The output is scalable and invertible.</p>	Current output
E	<p>Transmit signal off input The sensor's transmit signal is deactivated as long as the input is activated. The sensor does not send a measured value and sets the status to "No signal".</p> <p>Teach-in input The sensor can be taught in externally via pin 5.</p> <p>Deactivated The pin is deactivated.</p>	Teach-in input

6.2.1 Input Functions

The analog and switching outputs can be set via pin 5 using external teach-in:

Function	Possible settings	Default
External teach-in	<p>Supply voltage active Function is triggered as soon as supply voltage is applied to the input.</p> <p>Note: The time intervals required for this are: Activated for 2 sec. = Teach-in of the lower limit of the analog output Activated for 5 sec. = Teach-in of the upper limit of the analog output</p>	Supply voltage active

6.2.2 Output Functions

The output functions are used to set the physical outputs.

Function	Possible settings and functions	Default
PNP/NPN/ Push-pull	<p>PNP</p> <p>NPN</p> <p>Push-pull</p>	PNP

Function	Possible settings and functions	Default
NC/ NO	<p>Normally Open (NO) The output is high when the condition has been satisfied, depending on settings (switching point, warning, error).</p> <p>Normally Closed (NC) The output is low when the condition has been satisfied, depending on settings (switching point, warning, error).</p>	NO

Error Output

The error output is switched in the following cases:

- Very small or poorly reflective (sound-absorbing) objects are located within the working range
- Incorrect installation.
- The object is located outside of the working range.
- Strong air turbulence.
- Excessively strong ultrasound sources are located within the measuring range.

6.3 Condition Monitoring Functions

6.3.1 Status Message Function

The sensor provides various status messages. Due to the process data structure, four status messages can be transmitted as individual process data.

These parameters can be used to set the status messages that are transmitted via the process data.

Function	Possible Settings	Default
Message 1	See table "Status Messages"	Warning signal
Message 2	See table "Status Messages"	Short circuit
Message 3	See table "Status Messages"	Undervoltage
Message 4	See table "Status Messages"	No signal

6.3.2 Error Output Function

The status messages used to trigger the collective message can be defined for the error output respectively. The status messages are OR-linked so that the output is activated when one of the defined status messages is activated.

Function	Possible settings	Default
Error output	See table "Status Messages"	No signal, Object too close, Object too far, Short circuit, Device error

Status Messages

Warning	
Warning signal	The object reflects too little sound (weak signal).
Undervoltage	The supply voltage is too low.
Emitter off	The emitter of the sensor is switched off.

Error	
No signal	The sensor is not receiving a signal. The error can occur, for example, due to: <ul style="list-style-type: none"> • Strong air turbulence • Excessively strong ultrasonic sources in the measuring range • Very small or poorly reflective (sound-absorbing) objects are located within the working range • Incorrect installation
Object too close	The object is below the setting range or the set measuring range.
Object too far	The object is above the setting range or the set measuring range.
Short circuit	A short circuit has occurred on at least one pin.
Device error	A hardware error has occurred.

6.3.3 Simulation Functions

This function simulates the behavior of the sensor regardless of the current status and measured value. This can be used to check whether a plant in which the sensor is integrated reacts correctly to the data supplied by the sensor and processes them accordingly.

If a measured value is specified, the sensor behaves as if the specified measured value corresponds to the actual measured value. This means that the behavior of the outputs and status messages is simulated according to the specified measured value.

In addition, the individual outputs and status messages can be simulated separately from the measured value.

Function	Possible Settings	Default
Simulation mode	On Off	Off
Simulation Measured value	Current measured value min...max. measuring range	Current measured value
Simulation SSC1	According to the measured value On Off	According to Measured value
Simulation SSC2	According to the measured value On Off	According to Measured value
Simulation Status Messages	Tests the individual status messages According to the measured value On Off	According to Measured value



INFORMATION

Output A1 is used for IO-Link communication in this function and cannot be simulated.

Simulation mode ends automatically as soon as the power supply is interrupted.

6.4 Condition Monitoring/Process Data

The data described in the following section can be read or written cyclically via IO-Link/process data.

6.4.1 Process Data In

Data	Meaning
Measured value	Measured distance in mm or 1/10 inch As the sensor cannot determine a measured value in the following error cases, substitute values are read out: No signal: 0x7FFC / 32764 mm Object too close: 0x8008 / -32760 mm Object too far: 0x7FF8 / 32760 mm
Scale	Scaling of the measured value to the base length unit; -3 corresponds to mm.
SSC1	Switching point 1
SSC2	Switching point 2
Warning	Collective warning in the event of one of the warning status messages (see table "Status messages" in the error output function)
Error	Collective warning in the event of one of the error status messages (see table "Status messages" in error output function)
Message 1	Status message 1 read out see Status Message Function [▶ 23]
Message 2	Status message 2 read out see Status Message Function [▶ 23]
Message 3	Status message 3 read out see Status Message Function [▶ 23]
Message 4	Status message 4 read out see Status Message Function [▶ 23]

6.4.2 Process Data Out

Data	Meaning
Transmission signal	Transmit signal on/off NOTE! This parameter can be used to configure multiplex operation of the sensors. In the multiplex mode, ultrasonic sensors emit their pulses alternately. This mode of operation prevents sensors located in direct proximity to each other from interfering with one another.
Teach-in SSC1	Starts the teach-in process for SSC1
Teach-in SSC2	Starts the teach-in process for SSC2
External temperature value	Enter the external temperature in °C for temperature compensation

6.4.3 Events

Events are diagnostic information that is standardized by IO-Link and exchanged between the IO-Link master and the device. The following events are supported:

Name	Event code	Type	Specification
Device error – unknown error	0x1000	Error	IO-Link
Short circuit – check installation	0x7710	Error	IO-Link
Supply voltage too low – check tolerances	0x5111	Warning	IO-Link

7 **wTeach2 Configuration Software**

For information on installing and connecting the wTeach2 software and its structure, as well as information on the general functions, see the wTeach2 operating instructions. They can be found online in the download area at www.wenglor.com under order number DNNF005.

8 Maintenance Instructions



NOTICE

This wenglor sensor is maintenance-free.

Cleaning and inspection of the plug connections at regular intervals are advisable.

Do not clean the sensor with solvents or cleaning agents that could damage the product.

The product must be protected against contamination during initial start-up.

9 Proper Disposal

wenglor sensoric GmbH does not accept the return of unusable or irreparable products. Respectively valid national waste disposal regulations apply to product disposal.

10 **Declarations of Conformity**

Declarations of conformity can be found on our website at www.wenglor.com in the product's separate download area.