

# Flat Dome Light

white light, 1000 × 400 mm

## LFDW904

Part Number



- Easy and flexible installation
- High homogeneity
- High performance: high intensity even in continuous mode
- No external control required

The LFD series flat dome lights are high-diffuse lights with a camera connection. Due to their intense luminous flux and high homogeneity, they are perfectly suited for large-area applications such as robot-assisted pick-and-place. They can be used in continuous mode or synchronized with the machine vision camera in strobe mode via PNP or NPN inputs. The light is characterized by its narrow edges (4 mm) and easy mounting thanks to the T-slot fastener and the anchor point around the housing. Cameras can be connected easily on the rear of the light.

### Technical Data

Optical Data	
Light Source	White Light
Color temperature	6500 K
White light output	44300 Lux
Electrical Data	
Supply Voltage	21,6...26,4 V DC
Power	216 W
Current Consumption Continuous Mode (U <sub>b</sub> = 24 V)	9 A
Rise time	15 μs
Fall time	10 μs
Input signal	PNP/NPN
Temperature Range	-10...40 °C
Storage temperature	-20...60 °C
Short Circuit Protection	yes
Reverse Polarity Protection	yes
Overload Protection	yes
Protection Class	III
Dimming	0...10 V ± 100...30%
Overdrive	no
Mechanical Data	
Luminous Field Length (L)	1000 mm
Luminous Field Width (W)	400 mm
Luminous Field	1000 × 400 mm
Housing Material	Aluminum, anodised
Housing Material	Plastic, ABS/GF
Degree of Protection	IP50
UL Enclosure Type	1
Optic Cover	Plastic, PMMA
Connection	M12 × 1; 5-pin
Max. cable length	10 m
Camera aperture inner diameter	65 mm
Function	
Operating modes	Continuous, Strobe
Connection Diagram No.	007
Control Panel No.	T16
Suitable Mounting Technology No.	926

### Complementary Products

ZC4G003 connection cable
ZDCG004 connection cable
ZDCG005 connection cable

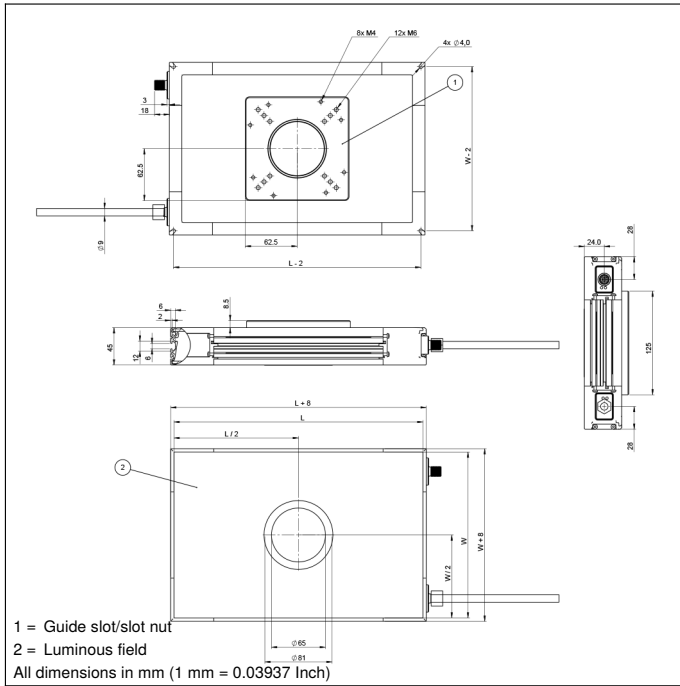

### Ctrl. Panel

**T16**

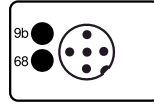

68 = Power LED  
 9b = Strobe Mode Indicator

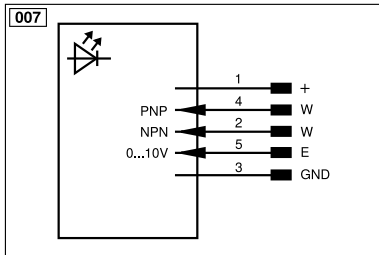

Legend			
+	Supply Voltage +	nc	Not connected
-	Supply Voltage 0 V	U	Test Input
~	Supply Voltage (AC Voltage)	Ü	Test Input inverted
A	Switching Output (NO)	W	Trigger Input
Ā	Switching Output (NC)	W-	Ground for the Trigger Input
V	Contamination/Error Output (NO)	O	Analog Output
ȳ	Contamination/Error Output (NC)	O-	Ground for the Analog Output
E	Input (analog or digital)	BZ	Block Discharge
T	Teach Input	Amv	Valve Output
Z	Time Delay (activation)	a	Valve Control Output +
S	Shielding	b	Valve Control Output 0 V
RxD	Interface Receive Path	SY	Synchronization
TxD	Interface Send Path	SY-	Ground for the Synchronization
RDY	Ready	E+	Receiver-Line
GND	Ground	S+	Emitter-Line
CL	Clock	±	Grounding
E/A	Output/Input programmable	SnR	Switching Distance Reduction
IO-Link	IO-Link	Rx+/-	Ethernet Receive Path
PoE	Power over Ethernet	Tx+/-	Ethernet Send Path
IN	Safety Input	Bus	Interfaces-Bus A(+)/B(-)
OSSD	Safety Output	La	Emitted Light disengageable
Signal	Signal Output	Mag	Magnet activation
BI_D+/-	Ethernet Gigabit bidirect. data line (A-D)	RES	Input confirmation
ENo RS422	Encoder 0-pulse 0/0 (TTL)	EDM	Contactor Monitoring
PT	Platinum measuring resistor	ENARs422	Encoder A/Ā (TTL)
			Encoder B/Ī (TTL)
			Encoder A
			Encoder B
			Digital output MIN
			Digital output MAX
			Digital output OK
			Synchronization In
			Synchronization OUT
			Brightness output
			Maintenance
			Reserved
			Wire Colors according to DIN IEC 60757
			BK Black
			BN Brown
			RD Red
			OG Orange
			YE Yellow
			GN Green
			BU Blue
			VT Violet
			GY Grey
			WH White
			PK Pink
			GNYE Green/Yellow