

Inductive Sensor with Full-Metal Housing

I12G002

Part Number

weproTec



- Easy sensor configuration using the IO-Link interface
- Increased switching distance
- Innovative ASIC circuit technology
- IO-Link 1.1
- Minimal mounting clearance thanks to wenglor weproTec

The inductive sensors with full-metal housing are suitable for harsh ambient conditions and washdown areas thanks to the 316L stainless steel housing. The sensors with full-metal housing impress with their easy installation and reliable switching behavior. In addition to error-free operation of several sensors in a very small space, the new generation also provides the possibility of detecting system errors before it's too late thanks to ASIC, IO-Link interface and wenglor weproTec.

Technical Data

Inductive Data	
Switching Distance	4 mm
Correction Factors Stainless Steel V2A/CuZn/Al	0,98/0,51/0,48
Mounting	Flush
Mounting A/B/C/D in mm	0/12/12/0
Mounting A/B/C/D (V2A) in mm	0/12/12/0
Mounting B1 in mm	0...2
Installation B1 (V2A) in mm	0...1
Switching Hysteresis	< 10 %
Electrical Data	
Supply Voltage	10...30 V DC
Supply Voltage with IO-Link	18...30 V DC
Current Consumption (U _b = 24 V)	< 15 mA
Switching Frequency	465 Hz
Temperature Drift	< 10 %
Temperature Range	-25...70 °C
Switching Output Voltage Drop	< 1 V
Switching Output/Switching Current	100 mA
Residual Current Switching Output	< 100 µA
Short Circuit Protection	yes
Reverse Polarity and Overload Protection	yes
Interface	IO-Link V1.1
Mechanical Data	
Housing Material	Stainless steel, V4A (1.4404 / 316L)
Sensing face	Stainless steel, V4A
Degree of Protection	IP67/IP68/IP69K *
Connection	M12 × 1; 4-pin
Torque	max. 25 Nm
Pressure Resistance Sensor Area	60 bar
EX II 3D Ex tc IIIC T90° Dc	yes
EX II 3G Ex ic IIC T5 Gc	yes
Safety-relevant Data	
MTTFd (EN ISO 13849-1)	3706,54 a
Packaging unit	1 Piece
PNP NC, PNP NO	●
Connection Diagram No.	215
Suitable Connection Equipment No.	2
Suitable Mounting Technology No.	170

* For applications inside hazardous areas: IP67

Complementary Products

IO-Link Master

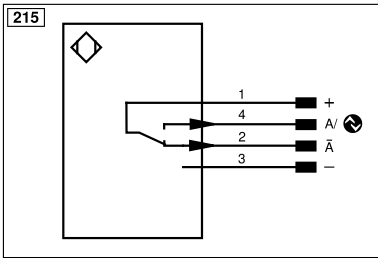
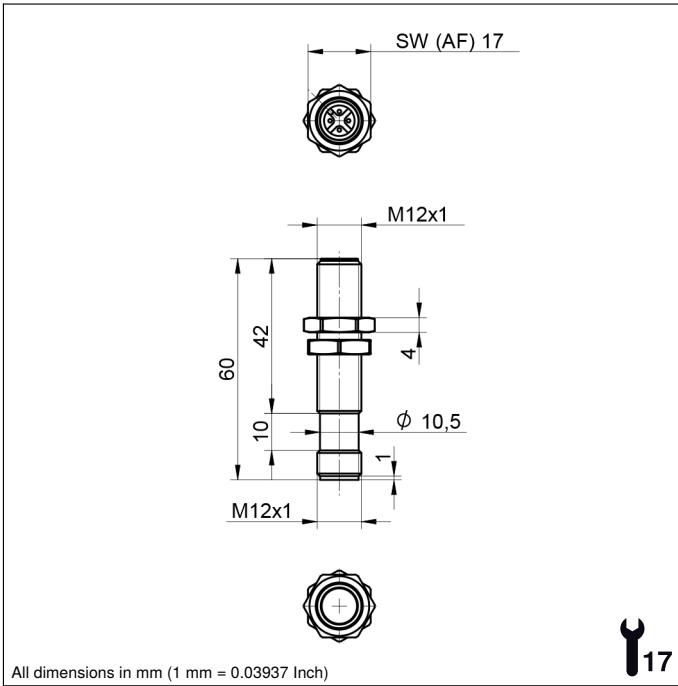

Legend					
+	Supply Voltage +	nc	Not connected	ENBR5422	Encoder B/B̄ (TTL)
-	Supply Voltage 0 V	U	Test Input	ENA	Encoder A
~	Supply Voltage (AC Voltage)	Ü	Test Input inverted	ENB	Encoder B
A	Switching Output (NO)	W	Trigger Input	AMIN	Digital output MIN
Ā	Switching Output (NC)	W-	Ground for the Trigger Input	AMAX	Digital output MAX
V	Contamination/Error Output (NO)	O	Analog Output	AOK	Digital output OK
V̄	Contamination/Error Output (NC)	O-	Ground for the Analog Output	SY In	Synchronization In
E	Input (analog or digital)	BZ	Block Discharge	SY OUT	Synchronization OUT
T	Teach Input	Amv	Valve Output	OLT	Brightness output
Z	Time Delay (activation)	a	Valve Control Output +	M	Maintenance
S	Shielding	b	Valve Control Output 0 V	rsv	Reserved
RxD	Interface Receive Path	SY	Synchronization	Wire Colors according to DIN IEC 60757	
TxD	Interface Send Path	SY-	Ground for the Synchronization	BK	Black
RDY	Ready	E+	Receiver-Line	BN	Brown
GND	Ground	S+	Emitter-Line	RD	Red
CL	Clock	±	Grounding	OG	Orange
E/A	Output/Input programmable	SnR	Switching Distance Reduction	YE	Yellow
IO-Link	IO-Link	Rx+/-	Ethernet Receive Path	GN	Green
PoE	Power over Ethernet	Tx+/-	Ethernet Send Path	BU	Blue
IN	Safety Input	Bus	Interfaces-Bus A(+)/B(-)	VT	Violet
OSSD	Safety Output	La	Emitted Light disengageable	GY	Grey
Signal	Signal Output	Mag	Magnet activation	WH	White
BL_D+/-	Ethernet Gigabit bidirect. data line (A-D)	RES	Input confirmation	PK	Pink
ENo RS422	Encoder 0-pulse 0/0̄ (TTL)	EDM	Contact Monitoring	GNYE	Green/Yellow
PT	Platinum measuring resistor	ENAR5422	Encoder A/Ā (TTL)		

Mounting

