

Industrial RFID Reader

with IO-Link

R30A001

weproTec



- 360° visible switching status display
- Data can be read, compared and written
- Frequency band 13.56 MHz
- Ready for Industry 4.0 with IO-Link 1.1
- Resistant to high temperature

RFID data

Working Range	0...50 mm*
Frequency band	13,56 MHz
Mounting	Non-flush
Mounting A/B/C/D in mm	30/60/90/10
RFID standard	ISO/IEC 15693

Electrical Data

Supply Voltage with IO-Link	18...32 V DC
Supply Voltage	11...32 V DC
Current Consumption (U _b = 24 V)	≤ 50 mA
Temperature Range	-25...80 °C
Storage temperature	-25...80 °C
Number of Switching Outputs	2
Switching Output/Switching Current	200 mA
Short Circuit Protection	yes
Overload Protection	yes
Reverse Polarity Protection	yes
Interface	IO-Link V1.1
IO-Link Version	1.1
Protection Class	III

Mechanical Data

Housing Material	Brass, chrome-plated
Sensing face	Plastic, PBT
Degree of Protection	IP67
Connection	M12 × 1; 4-pin

Safety-relevant Data

MTTFd (EN ISO 13849-1)	644 a
------------------------	-------

Function

Error Indicator	yes
IO-Link	●
PNP NO	●
Connection Diagram No.	272
Suitable Connection Equipment No.	2
Suitable Mounting Technology No.	130 132

* The specified working range relates to a transponder with Ø 50 mm and RSSI ≥ 0. Depending on the transponder, the resulting working range may vary.

Thanks to RFID technology, these RFID readers enable fast and seamless data exchange with RFID transponders. The IO-Link interface makes it easy to change parameters and transfer process data efficiently. With a frequency band of 13.56 MHz, RFID readers offer a reliable identification solution for close-range applications.

Complementary Products

IO-Link Master Software

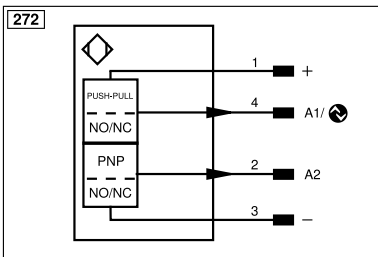
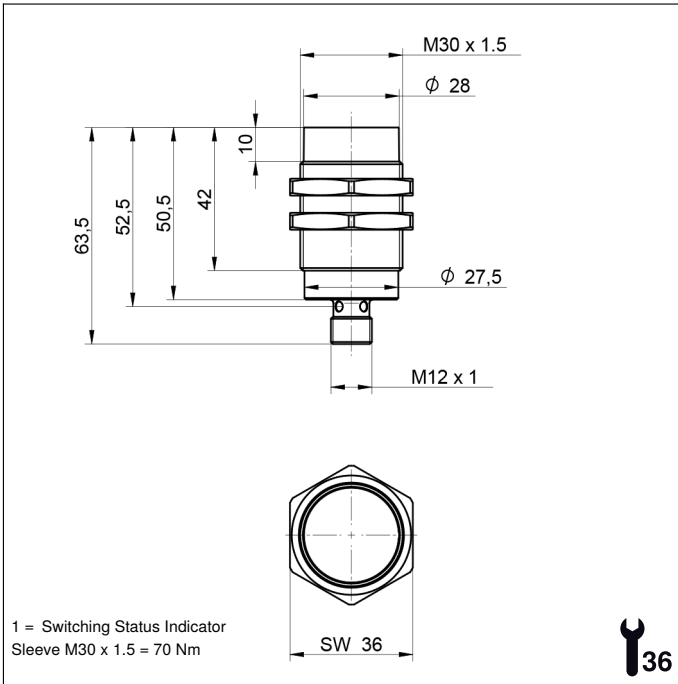

Mounting

