

B60xxx

Smart Cameras and Vision Sensors

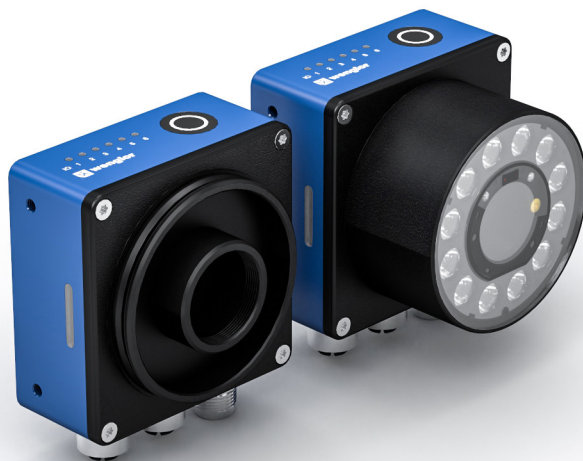

Operating Instructions

Original operating instructions
Subject to change without notice
Available as PDF file only
Revision level: 20.05.2026
Version 1.8.0
www.wenglor.com

Table of Contents

1. General	5
1.1 Information Concerning these Instructions	5
1.2 Explanations of Symbols	5
1.3 Limitation of Liability	6
1.4 Copyrights	6
2. For Your Safety	7
2.1 Use for Intended Purpose	7
2.2 Use for Other than the Intended Purpose	7
2.3 Personnel Qualifications	7
2.4 LED/Laser Warnings	8
2.4.1 LED Radiation of Illumination Modules	8
2.4.2 Laser Radiation of the visual field marking (Laser Pattern)	8
2.4.3 Laser Radiation of the Distance Sensor	8
2.5 Modification of Products	9
2.6 Repair	9
2.7 General Safety Precautions	9
2.8 Conditions for specified Degree of Protection	9
2.9 Approvals	10
3. Technical Data	10
3.1 General Data	10
3.1.1 B60 C Mount	10
3.1.2 B60 AF (auto-focus) wide	11
3.1.3 B60 AF (auto-focus) narrow	12
3.1.4 Hardware Release Notes	15
3.1.5 Order Number	16
3.1.6 Illumination Modules Z60F	17
3.1.6.1 Homogeneity and Intensity (Irradiance)	18
3.1.7 Multizone Distance Sensor	21
3.1.8 Trigger prohibited time	23
3.1.9 Spectral sensitivity characteristics of the image chips	24
3.2 Fields of View (FoV)	26
3.3 Dimensional Drawing	29
3.4 Connection Diagram	30
3.5 Complementary Products	32
3.6 Construction	33
3.6.1 B60 C Mount	33
3.6.2 B60 AF	34

3.6.3	Illumination Module	34
3.7	Control Panel / Button / Indicator elements	35
3.7.1	I/O-Status LEDs	35
3.7.2	Button	35
3.7.3	Device Status LEDs	36
3.7.4	Connector LEDs	37
3.7.5	Test Object Status LEDs	37
3.7.6	Visual Field Marking (Laser Pattern)	38
3.8	Heat sink	38
3.9	Scope of Delivery	39
4.	Transport and Storage	39
4.1	Transport	39
4.2	Storage	39
5.	Installation and Electrical Connection	40
5.1	System overview	40
5.2	Mounting and General Installation Instructions	40
5.2.1	Cable Outlet with Angled Plugs	41
5.2.2	Mounting option for Robot Vision with Universal Robots (UR)	41
5.2.3	Tightening Torques	42
5.2.4	Assembly of Illumination Modules	42
5.2.5	Assembly of Filters on Illumination Modules	43
5.3	Electrical Connection	44
5.4	Connection to External Illumination and Trigger Sensor	45
5.5	Adjusting LAN Network Settings	48
5.5.1	Manual LAN Network Settings	48
5.5.2	Test Connection between Smart Camera and PC	50
6.	Software wenglor weHub	50
7.	Device Website	51
7.1	Structure of Device Website	52
7.2	Dashboard	53
7.3	Interfaces	54
7.3.1	Network (LAN)	54
7.3.2	FTP/SFTP Client	55
7.3.3	weHub Server	56
7.3.4	Industrial Ethernet	56

7.3.5	NTP Client	57
7.4	Jobs	59
7.5	File Management	64
7.6	Diagnosis	65
7.6.1	CPU	65
7.6.2	RAM	66
7.6.3	LAN Ethernet	66
7.6.4	Storage	67
7.6.5	Position Sensor	67
7.6.6	Temperature	68
7.6.7	Browser Data	68
7.6.8	Logging	69
7.6.9	Simulation Mode	69
7.7	Settings	70
7.7.1	Button	70
7.7.2	Position Sensor	71
7.7.3	Distance Sensor	73
7.7.4	Laser Pattern	75
7.7.5	Reboot & Reset	76
7.7.6	Update	76
7.7.7	Backup	78
7.7.8	Security	79
7.7.9	Webserver	82
7.7.10	Appearance	84
7.7.11	Language	85
7.8	Device Status	85
7.9	Help Button	86
8.	Software wenglor uniVision 3	87
9.	Maintenance Instructions	87
10.	Proper Disposal	87
11.	Change Index of Operating Instruction	88
12.	Appendix	89
12.1	Declarations of Conformity	89
12.2	Third Party Licenses	89

1. General

1.1 Information Concerning these Instructions

- These instructions enable safe and efficient use of B60 Smart Cameras.
- These instructions are an integral part of the product and must be kept on hand for the entire duration of its service life.
- Local accident prevention regulations and national work safety regulations must be complied with as well.
- The product is subject to further technical development, and thus the information contained in these operating instructions may also be subject to change. The current version can be found at www.wenglor.com in the product's separate download area.



NOTE!

The operating instructions must be read carefully before using the product and must be kept on hand for later reference.

1.2 Explanations of Symbols

- Safety precautions and warnings are emphasized by means of symbols and attention-getting words.
- Safe use of the product is only possible if these safety precautions and warnings are adhered to.

The safety precautions and warnings are laid out in accordance with the following principle:



ATTENTION-GETTING WORD!

Type and Source of Danger!

Possible consequences in the event that the hazard is disregarded.

- Measures for averting the hazard.
-

The meanings of the attention-getting words, as well as the scope of the associated hazards, are listed below:



DANGER!

This word indicates a hazard with a high degree of risk which, if not avoided, results in death or severe injury.



Warning!

This word indicates a hazard with a medium degree of risk which, if not avoided, may result in death or severe injury.



CAUTION!

This word indicates a hazard with a low degree of risk which, if not avoided, may result in minor or moderate injury.



ATTENTION!

This word draws attention to a potentially hazardous situation which, if not avoided, may result in property damage.



NOTE!

A note draws attention to useful tips and suggestions, as well as information regarding efficient, error-free use.

1.3 Limitation of Liability

- The product has been developed taking into account the state of the art as well as the applicable standards and guidelines.
- We reserve the right to make technical changes.
- A valid declaration of conformity can be found at www.wenglor.com in the download area of the product.
- wenglor sensoric elektronische Geräte GmbH (hereinafter „wenglor“) accepts no liability for:
 - » Failure to observe the operating manual,
 - » Unsuitable or improper use of the product,
 - » Excessive use, incorrect or negligent treatment of the product,
 - » Incorrect installation or commissioning,
 - » Use of untrained personnel,
 - » Use of unauthorized spare parts or
 - » Improper or unauthorized changes, modifications or repair work to the products.
- This operating manual does not contain any guarantees/warranties from wenglor with regard to the processes described or certain product properties.
- wenglor assumes no liability with regard to printing errors or other inaccuracies contained in this operating manual, unless it can be proven that wenglor was aware of the errors at the time the operating manual was created.

1.4 Copyrights

- The contents of these instructions are protected by copyright law.
- All rights are reserved by wenglor.
- Commercial reproduction or any other commercial use of the provided content and information, in particular graphics and images, is not permitted without previous written consent from wenglor.

2. For Your Safety

2.1 Use for Intended Purpose

This wenglor product is intended for use in accordance with the following functional principle:

The Smart Camera B60 is an industrial image capture and processing sensor used for non-contact inspection of specific objects. The Smart Camera combines image acquisition and evaluation in one housing and operates with a CMOS color or monochrome image sensor.

With the wenglor uniVision image processing software [DNNF023](#) (version 3.0.0 or higher) and a PC or laptop, the image processing functions of the corresponding uniVision license package can be configured. Typical applications are reading, 1D codes, 2D codes or OCR, presence check of best before date or checking the correct assembly at automatic manufacturing processes.

These image processing functions can be executed in trigger mode as well as in continuous monitoring mode, where objects can be detected regardless of their position thanks to tracking. Six digital I/Os are available, which can be used as input or output as required.

The product is primarily designed for use in industrial and logistic areas and meets the requirements for industrial robustness, interfaces as well as data processing.

2.2 Use for Other than the Intended Purpose

- The product is not a safety component in accordance with the EC Machinery Directive.
- The product is not suitable for use in potentially explosive atmospheres.
- The product may be used only with accessories supplied or approved by wenglor, or in combination with approved products. A list of approved accessories and combination products can be found at www.wenglor.com on the product detail page.



WARNING!

Risk of personal injury or property damage in case of use for other than the intended purpose!

Use for other than the intended purpose may lead to hazardous situations.

- Instructions regarding use for intended purpose must be observed.
-

2.3 Personnel Qualifications

- Suitable technical training is a prerequisite.
- In-house electronics training is required.
- Trained personnel who use the product must have (uninterrupted) access to the operating instructions.



DANGER!

Risk of personal injury or property damage in case of incorrect initial start-up and maintenance!

Personal injury and damage to equipment may occur.

- Adequate training and qualification of personnel.
-

2.4 LED/Laser Warnings

Observe the safety and warning instructions listed here to avoid dangerous situations and reduce health hazards.

Operation with external lighting can lead to the risks described here being exceeded and must be considered by the user on a case-by-case basis.

For more details see operating instructions of the external lighting.

2.4.1 LED Radiation of Illumination Modules

(not included in scope of delivery)

CAUTION!

Optical radiation LED risk group 1, visible radiation, 400...780 nm.

Possible eye hazard if not used as intended.



- Do not look directly into the light source during operation.
- Observe applicable national regulations on the photobiological safety of lamps and lamp systems

CAUTION!

Optical radiation LED risk group 1, invisible radiation, 850 nm.

Possible eye hazard if not used as intended.



- Do not look directly into the light source during operation.
- Observe applicable national regulations on the photobiological safety of lamps and lamp systems

2.4.2 Laser Radiation of the visual field marking (Laser Pattern)

(Only for auto-focus devices)

LASER CLASS 1
EN 60825-1:2007

Laser class 1 (EN 60825-1) / 650 nm

Applicable standards and safety regulations must be observed.

2.4.3 Laser Radiation of the Distance Sensor

(Only for auto-focus devices if illumination module is used)

LASER CLASS 1
EN 60825-1:2007

Laser class 1 (EN 60825-1) / 940 nm

Applicable standards and safety regulations must be observed.

2.5 Modification of Products



DANGER!

Risk of personal injury or property damage if the product is modified!

Personal injury and damage to equipment may occur. Non-observance may result in loss of the CE and/or UKCA mark and the guarantee may be rendered null and void.

- Modification of the product is impermissible.
 - Unauthorized opening of the device is not permitted.
-

2.6 Repair

Trained and authorized wenglor personnel may only carry out repairs to the device. Interventions and modifications to the device by the customer will void the warranty claim against wenglor.

2.7 General Safety Precautions



NOTE!

- These instructions are an integral part of the product and must be kept on hand for the entire duration of its service life.
 - In the event of possible changes, the respectively current version of the operating instructions can be accessed at www.wenglor.com in the product's separate download area.
 - Read the operating instructions carefully before using the product.
 - The Smart Camera must be protected against contamination and mechanical influences.
-



DANGER!

Danger due to possibly dangerous optical or infrared radiation of the illumination (not included in the scope of delivery)!

Damage to the eyes possible.

- Do not look directly into the illumination during operation.
-



CAUTION!

Danger of burns under specific conditions (e.g. high ambient temperature)!

Do not touch the housing while the device is running or shortly after switching it off, as it remains very hot.

2.8 Conditions for specified Degree of Protection

To maintain the specified degree of protection of the device during operation, the following specifications apply. In case of non-compliance, the device does not comply with any specified degree of protection.

- The connected cables at the electrical connections are screwed.
 - Any unused electrical connections are sealed with a screwed-on protective cap.
 - The protective tube is screwed tightly to the device.
-



ATTENTION!

Risk of damage to the product if the conditions are not complied with

In case of non-compliance, the device does not comply with any specified protection class.

2.9 Approvals

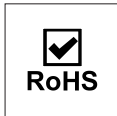

3. Technical Data

3.1 General Data

The B60 is available in 3 different software packages:

- B60Mxxx: uniVision
- B60Exxx: uniVision Extended
- B60Pxxx: uniVision Script
- B60Axxx: uniVision AI

All currently associated software modules can be found at:

[Product Highlights of uniVision 3](#)

3.1.1 B60 C Mount

Technical Data	Order No.	B60x103	B60x113	B60x203	B60x213
Optical Data					
Lens thread		C-Mount			
Resolution		1440 x 1080 Pixel		2448 x 2048 Pixel	
Resolution		1,6 MP		5 MP	
Image Chip		monochrome	color	monochrome	color
Image chip size		1/2,9"		1/1,8"	
Pixel size		3,45 x 3,45 µm		2,74 x 2,74 µm	
Light source		External lighting			
Frame rate		≤ 60 fps ¹	≤ 60 fps ¹	≤ 67 fps ¹	≤ 67 fps ¹
Environmental conditions					
Temperature range		0...40 °C ²			
Storage temperature		0...70 °C			
Atmospheric humidity		5...95 %, non-condensing			
Shock resistance (DIN IEC 68-2-27)		30 g / 11 ms			
Vibration resistance (DIN EN 60068-2-64)		6 g (10...55 Hz)			
Electrical Data					
Supply Voltage		24 VDC			
Current Consumption (U _b = 24 V)		600 mA ³			
Inputs/outputs		6			
Switching Output Voltage Drop		< 2,5 V			
Switching Output/Switching Current		100 mA			
Short circuit protection		yes			

Reverse polarity protection	yes
Interface	Ethernet
Industry protocols	PROFINET Class B, EtherNet/IP, EtherCAT
General protocols	FTP, sFTP, TCP/IP, UDP
Baud rate Ethernet	1 Gbit/s
Baud rate PROFINET	100 Mbit/s
Protection class	III
RAM	4 GB ⁴
Storage Capacity	32 GB ⁵
PoE Class	4 ⁶
Mechanical Data	
Housing material	Aluminium, anodised
Optic cover	Glass
Degree of protection	IP67
Connection	M12 x 1; 12-pin
Type of connection Ethernet	M12 x 1; 8-pin, X-coded (2x)
General Data	
Web server	yes
Output	
PNP NO	yes
Adjustable Parameters	
Output	Push-Pull, NPN, PNP
Circuit	NC/NO, NC, NO
Safety-relevant Data	
MTTFd (EN ISO 13849-1)	174,12 a

Descriptions of the text passages marked with an annotation number can be found in section 3.1.3.

3.1.2 B60 AF (auto-focus) wide

Technical Data	Order No.	B60x101	B60x111	B60x201	B60x211
Optical Data					
Range		> 50 mm			
Resolution		1440 x 1080 Pixel		2448 x 2048 Pixel	
Resolution		1,6 MP		5 MP	
Focal distance		6 mm		7 mm	
Image Chip		monochrome	color	monochrome	color
Image chip size		1/2,9"		1/1,8"	
Pixel size		3,45 x 3,45 µm		2,74 x 2,74 µm	
Light source		Z60F Illumination module			
Frame rate		≤ 60 fps ¹	≤ 60 fps ¹	≤ 67 fps ¹	≤ 67 fps ¹
Environmental conditions					
Temperature range		0...40 °C ²			
Storage temperature		0...70 °C			
Atmospheric humidity		5...95 %, non-condensing			
Shock resistance (DIN IEC 68-2-27)		30 g / 11 ms			
Vibration resistance (DIN EN 60068-2-64)		6 g (10...55 Hz)			

Electrical Data	
Supply Voltage	24 VDC
Current Consumption (U _b = 24 V)	700 mA ³
Inputs/outputs	6
Switching Output Voltage Drop	< 2,5 V
Switching Output/Switching Current	100 mA
Short circuit protection	yes
Reverse polarity protection	yes
Interface	Ethernet
Industry protocols	PROFINET Class B, EtherNet/IP, EtherCAT
General protocols	FTP, sFTP, TCP/IP, UDP
Baud rate Ethernet	1 Gbit/s
Baud rate PROFINET	100 Mbit/s
Protection class	III
RAM	4 GB ⁴
Storage Capacity	32 GB ⁵
PoE Class	4 ⁶
Mechanical Data	
Minimum object distance	50 mm
Housing material	Aluminium, anodised
Optic cover	Plastic, PMMA
Degree of protection	IP67
Connection	M12 x 1; 12-pin
Type of connection Ethernet	M12 x 1; 8-pin, X-coded (2x)
General Data	
Web server	yes
Output	
PNP NO	yes
Function	
Multizone Distance Sensor	yes ⁷
Adjustable Parameters	
Output	Push-Pull, NPN, PNP
Circuit	NC/NO, NC, NO
Safety-relevant Data	
MTTFd (EN ISO 13849-1)	149,4 a

Descriptions of the text passages marked with an annotation number can be found in section 3.1.3.

3.1.3 B60 AF (auto-focus) narrow

Order No.	B60x102	B60x112	B60x202	B60x212
Technical Data				
Optical Data				
Range	> 100 mm			
Resolution	1440 x 1080 Pixel		2448 x 2048 Pixel	
Resolution	1,6 MP		5 MP	
Focal distance	12 mm		17,5 mm	
Image Chip	monochrome	color	monochrome	color
Image chip size	1/2,9"		1/1,8"	

Pixel size	3,45 x 3,45 µm	2,74 x 2,74 µm
Light source	Z60F Illumination module	
Frame rate	≤ 60 fps ¹	≤ 67 fps ¹
Environmental conditions		
Temperature range	0...40 °C ²	
Storage temperature	0...70 °C	
Atmospheric humidity	5...95 %, non-condensing	
Shock resistance (DIN IEC 68-2-27)	30 g / 11 ms	
Vibration resistance (DIN EN 60068-2-64)	6 g (10...55 Hz)	
Electrical Data		
Supply Voltage	24 VDC	
Current Consumption (U _b = 24 V)	700 mA ³	
Inputs/outputs	6	
Switching Output Voltage Drop	< 2,5 V	
Switching Output/Switching Current	100 mA	
Short circuit protection	yes	
Reverse polarity protection	yes	
Interface	Ethernet	
Industry protocols	PROFINET Class B, EtherNet/IP, EtherCAT	
General protocols	FTP, sFTP, TCP/IP, UDP	
Baud rate Ethernet	1 Gbit/s	
Baud rate PROFINET	100 Mbit/s	
Protection class	III	
RAM	4 GB ⁴	
Storage Capacity	32 GB ⁵	
PoE Class	4 ⁶	
Mechanical Data		
Minimum object distance	100 mm	
Housing material	Aluminium, anodised	
Optic cover	Plastic, PMMA	
Degree of protection	IP67	
Connection	M12 x 1; 12-pin	
Type of connection Ethernet	M12 x 1; 8-pin, X-coded (2x)	
General Data		
Web server	yes	
Output		
PNP NO	yes	
Function		
Multizone Distance Sensor	yes ⁷	
Adjustable Parameters		
Output	Push-Pull, NPN, PNP	
Circuit	NC/NO, NC, NO	
Safety-relevant Data		
MTTFd (EN ISO 13849-1)	149,4 a	

¹ Frame rate: Maximum fps adjustable in software if Trigger Mode is set to Off and Region Mode in Image Format Control is set to Off. The maximum fps values in case of Region Mode set to On are (width and height are fixed at half the image chip width/height):

- 120 Hz for 1.6 MP monochrome
- 120 Hz for 1.6 MP color
- 128 Hz for 5 MP monochrome
- 128 Hz for 5 MP color

Recommended maximum frequencies for the complete readout area (e.g. to avoid data overflow) are:

- 50 Hz for B60 1.6 MP monochrome
- 50 Hz for B60 1.6 MP color
- 50 Hz for B60 5 MP monochrome
- 30 Hz for B60 5 MP color

Please also consider the trigger prohibited time (see following section) and that the processing time in uniVision is short enough to handle the required trigger frequency. In case of data overflow the error handling of the device takes care of a defined behavior (see operating instructions of software wenglor uniVision 3 [DNNF023](#)).

² Temperature range: The internal temperature is approx. 10...30° C above the ambient temperature. Use in areas with ambient temperatures above the specified ones may result in CPU throttling (depending on the computing intensity). Use the sensor only in the specified temperature range to avoid damage and shortening of the service life.

³ Especially at bootup current peaks of up to 800 mA can appear. Make sure that the power supply provides enough current.

Current consumption for illumination module needs to be considered separately. Check technical data of illumination module (see section „[3.1.6 Illumination Modules Z60F](#)“).

⁴ Depending on the model and hardware revision, the Smart Camera has 2 GB or 4 GB RAM (volatile memory).

- B60A: 4 GB RAM
- B60M, B60E, B60P:
 - » C-Mount 1,6 MP: 4 GB RAM from revision G
 - » C-Mount 5 MP: 4 GB RAM from revision F
 - » Autofocus: 4 GB RAM from revision D

Earlier revisions: 2 GB RAM

On devices with 4 GB RAM, part of the memory is reserved by the hardware and operating system for system purposes. This means that up to approx. 3.4 GB RAM is available for user applications.

⁵ Depending on the model and hardware revision, the Smart Camera has 16 GB or 32 GB of internal memory.

- B60A: 32 GB
- B60M, B60E, B60P:
 - » C-Mount 1,6 MP: 32 GB from revision G
 - » C-Mount 5 MP: 32 GB from revision F
 - » Autofocus: 32 GB from revision D

Earlier revisions: 16 GB

Part of the memory is used by the operating system and preinstalled software. This leaves approximately 2 GB (for 16 GB memory) or approximately 13 GB (for 32 GB memory) available for user data.

⁶ Depending on the model and hardware revision, the Smart Camera complies with PoE Class 0 or 4.

- B60A: Class 4
- B60M, B60E, B60P:
 - » C-Mount 1,6 MP: Klasse 4 ab Revision G
 - » C-Mount 5 MP: Klasse 4 ab Revision F
 - » Autofokus: Klasse 4 ab Revision D

⁷ When using an illumination module

3.1.4 Hardware Release Notes

Order number	Hardware Revision	Important changes	Firmware Compatibility
B60A*	-	-	FW 1.7.0 or later
B60x1x3 (C-Mount, 1,6 MP)	F and earlier	-	FW 1.0.0 or later
B60x1x3 (C-Mount, 1,6 MP)	G and later	More RAM and internal storage (see technical data), new design for button and light pipe (device status LED), new dimensions for auto focus devices only: 70x70x65 mm (before: 70x70x64,5 mm)	FW 1.7.0 or later
B60x2x3 (C-Mount, 5 MP)	E and earlier	-	FW 1.0.0 or later
B60x2x3 (C-Mount, 5 MP)	F and later	More RAM and internal storage (see technical data), new design for button and light pipe (device status LED), new dimensions for auto focus devices only: 70x70x65 mm (before: 70x70x64,5 mm)	FW 1.7.0 or later
B60M* / B60E* / B60P* (Autofokus)	C and earlier	-	FW 1.0.0 or later
B60M* / B60E* / B60P* (Autofokus)	D and later	More RAM and internal storage (see technical data), new design for button and light pipe (device status LED), new dimensions for auto focus devices only: 70x70x65 mm (before: 70x70x64,5 mm)	FW 1.7.0 or later

3.1.5 Order Number

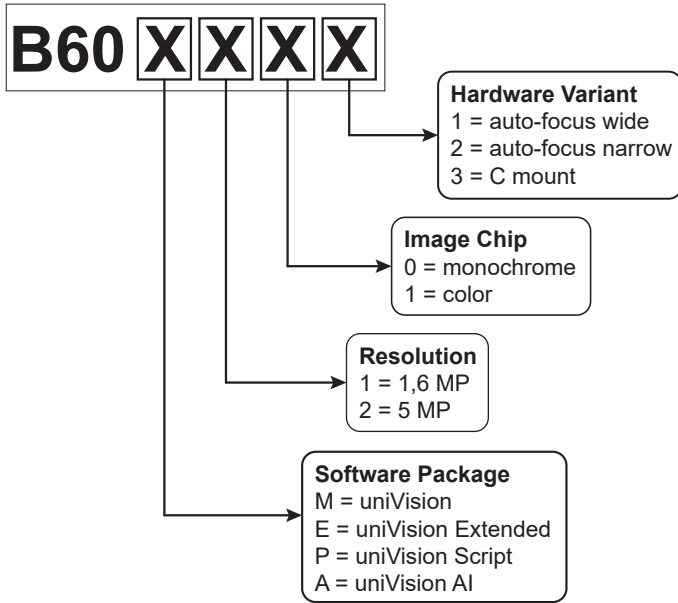

3.1.6 Illumination Modules Z60F

(not included in scope of delivery)

Order No.	Z60F001	Z60F002	Z60F003	Z60F004	Z60F005
Technical Data					
Optical Data					
Light source	White Light	IR	RGBW	White Light	IR
Color temperature	5800 K		6500 K	5800 K	
Wavelength		850 nm	Red = 625 nm Green = 525 nm Blue = 453 nm		850 nm
Beam angle	92°	92°	120°	32°	32°
Electrical Data					
Current consumption continuous/strobe mode (U _b = 24 V)	< 200 mA				
Current consumption strobe overdrive mode (U _b = 24 V)	1,1 A				
Flash duration	0,05...20 ms ¹				
Duty cycle	0,1 ²				
Protection class	III				
Dimming	Software wenglor uniVision 3 ³				
Overdrive	yes				
Mechanical Data					
Weight	60 g				
Function					
Operating modes	Continuous, Strobe, Strobe Overdrive				
Multizone Distance Sensor	yes				
General Data					
Scope of delivery	1 x Illumination module, 1 x Angle Changer	1 x Illumination module, 1 x Angle Changer	1 x Illumination module	1 x Illumination module	1 x Illumination module
Safety-relevant Data					
MTTFd (EN ISO 13849-1)	1236,87 a	1313,04 a	834,07 a	1236,87 a	1313,04 a

- ¹
- Relevant only for the Strobe Overdrive mode.
 - Flash duration depends on the exposure time.
 - If the specified maximum flash duration is exceeded (via longer exposure times), the lighting switches off automatically.

² Only relevant for Strobe Overdrive mode. Make sure that the maximum trigger frequency does not exceed the allowed duty cycle of the illumination module. E.g. after exposing and flashing of 1 ms, the illumination module needs at least 9 ms until it is ready again for the next flashing.

³ The brightness of the lighting can be set in the wenglor uniVision 3 software.

3.1.6.1 Homogeneity and Intensity (Irradiance)

NOTE!



- Brightness reference point for measuring the irradiance is the center of the field of view (FOV)
- At distances of 100, 200 and 300 mm, the homogeneity heat maps correspond to the full field of view of the camera. At 500mm distance, 300 × 300 mm was cut out of the center of the field of view.



Z60F001 (white light, auto-focus wide)

Distance (mm)	Homogeneity heat map	Mode	Irradiance (W/m ²)	Intensity
100 FOV: 78 × 58 mm		Continuous	11	
		Strobe overdrive	74,25	
200 FOV: 161 × 120 mm		Continuous	4	
		Strobe overdrive	27	
300 FOV: 243 × 183 mm		Continuous	2	
		Strobe overdrive	13,5	
500 FOV: 409 × 307 mm		Continuous	1	
		Strobe overdrive	6,75	

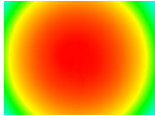
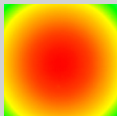
Z60F004 (white light, auto-focus narrow)

Distance (mm)	Homogeneity heat map	Mode	Irradiance (W/m ²)	Intensity
100 FOV: 78 × 58 mm		Continuous	35	
		Strobe overdrive	236,25	
200 FOV: 161 × 120 mm		Continuous	16	
		Strobe overdrive	108	
300 FOV: 243 × 183 mm		Continuous	8	
		Strobe overdrive	54	
500 FOV: 409 × 307 mm		Continuous	3	
		Strobe overdrive	20,25	

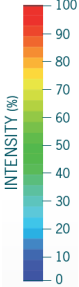
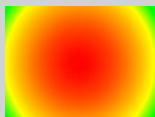
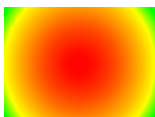

Z60F002 (IR, auto-focus wide)

Distance (mm)	Homogeneity heat map	Mode	Irradiance (W/m ²)	Intensity
100 FOV: 78 × 58 mm		Continuous	12	
		Strobe overdrive	81	
200 FOV: 161 × 120 mm		Continuous	4	
		Strobe overdrive	27	
300 FOV: 243 × 183 mm		Continuous	2	
		Strobe overdrive	13,5	
500 FOV: 409 × 307 mm		Continuous	1	
		Strobe overdrive	6,75	

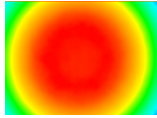
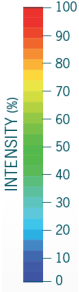
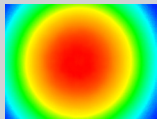
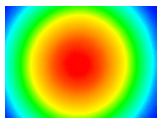
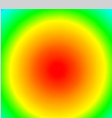
Z60F005 (IR, auto-focus narrow)

Distance (mm)	Homogeneity heat map	Mode	Irradiance (W/m ²)	Intensity
100 FOV: 78 × 58 mm		Continuous	36	
		Strobe overdrive	243	
200 FOV: 161 × 120 mm		Continuous	23	
		Strobe overdrive	155,25	
300 FOV: 243 × 183 mm		Continuous	15	
		Strobe overdrive	101,25	
500 FOV: 409 × 307 mm		Continuous	6	
		Strobe overdrive	40,5	

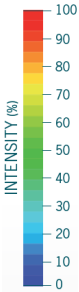
Z60F003 (RGB)

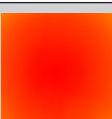
Distance (mm)	Homogeneity heat map	Mode	Irradiance (W/m ²)	Intensity
100 FOV: 78 × 58 mm		Continuous	10	
		Strobe overdrive	67,5	
200 FOV: 161 × 120 mm		Continuous	3	
		Strobe overdrive	20,25	
300 FOV: 243 × 183 mm		Continuous	1	
		Strobe overdrive	6,75	
500 FOV: 409 × 307 mm		Continuous	< 1	
		Strobe overdrive	< 3	



NOTE!

A B60M101 (auto focus wide) was used for the measurement. For auto focus narrow variants the homogeneity does not differ - the camera only covers a smaller part of the heat map.

Product Service Life

The service life of LEDs can generally be increased by using strobe or strobe overdrive mode. Flashing the light or switching the illumination on and off allows the LED chip to heat up less. The chip temperature of the LED correlates directly with the service life of the LED chip.



NOTE!

Information on the construction and assembly of the illumination modules can be found in the sections „3.6.3 Illumination Module“ and „5.2.4 Assembly of Illumination Modules“.



NOTE!

Information on handling LED radiation can be found in section „2.4.1 LED Radiation of Illumination Modules“.

3.1.7 Multizone Distance Sensor

(not included in scope of delivery)

For information on activating and deactivating the distance sensor, see section „7.7.3 Distance Sensor“.

Technical Data

Wave length	940 nm
Frame rate	30 Hz
Range	20...4000 mm ¹
Linearity deviation	± 4% ²
Distance values	16

¹ If individual values are not detected (e.g. due to insufficient reflection at a large distance) or if the measured distance values are outside this range, “not available” is displayed on the device website and “-1” is displayed in the chunk data.

² For white objects with 88% reflectance. For further values, see the following table:

Distance	Target reflectance	Dark	Ambient light (5klux)
20...200 mm	Grey target (17%)	±15 mm	±15 mm
201...4000 mm	White target (88%)	±4%	±7%
	Grey target (17%)	±5%	±8%

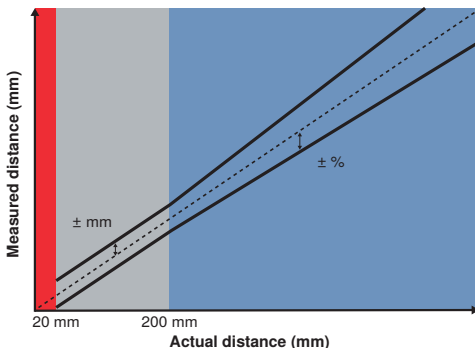

Numerical arrangement of the individual distance values in the field of view:



NOTE!

- Only available for auto-focus devices if the illumination module is used.
- Specified values refer to devices without mounted protective tube.
- Reflections of the laser light in the camera image are to be expected, particularly with shiny objects, if: the internal illumination is switched off and/or the exposure time is short.
- It is recommended to use the Z60G001 filter to avoid reflections in the camera image. In this case the IR illumination module should not be used.
- The FoV of the distance sensor is identical for both auto-focus variants and depends on the working distance.
- Wait an additional five seconds after the processing instance is ready to receive valid data from the distance sensor (until valid results are available, the value of the distance sensor is set to error status).



3.1.8 Trigger prohibited time

Please consider that trigger signals while exposing and while reading out the image chip must be prevented as they are ignored by the software. The prohibited time after a trigger signal if using the complete readout area is

- for B60 1.6 MP:
Exposure time + 17 ms readout time = trigger prohibited time
- for B60 5 MP:
Exposure time + 15 ms readout time = trigger prohibited time

Example: In the following illustration, the second trigger will be ignored. Triggers 3 and 4 are outside the prohibited time and are taken into account.

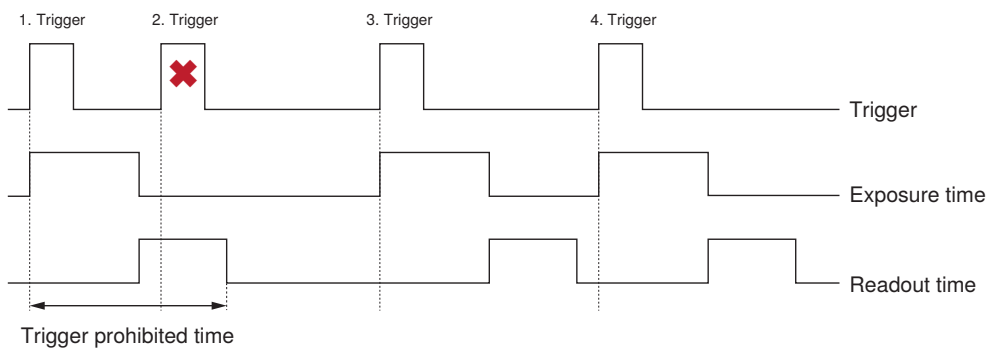

Evaluate "Missed Trigger Counter" at Chunk Data Control of Device Smart Camera to check for too fast trigger signals. For details, see uniVision operating instructions ([DNNF023](#)).

NOTE!



If using Region Mode "On" at Image Format Control for the reduced readout area, the following trigger prohibited times exist for each device type:

- for B60 1.6 MP: 9 ms
- for B60 5 MP: 8 ms

3.1.9 Spectral sensitivity characteristics of the image chips

(Lens and light source characteristics excluded)

1,6 MP mono

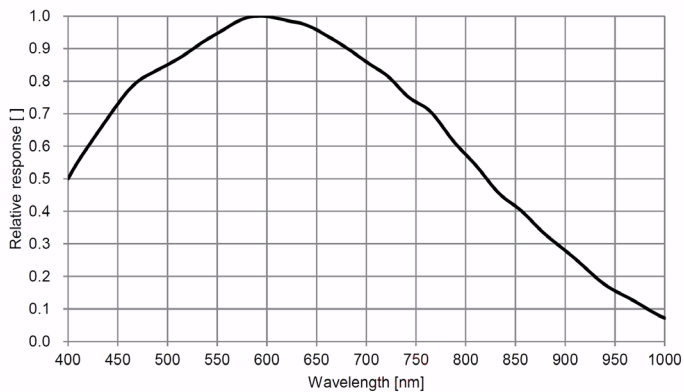

1,6 MP color

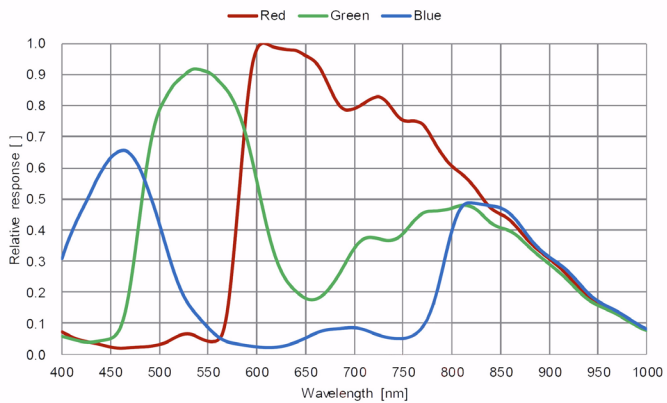

5 MP mono

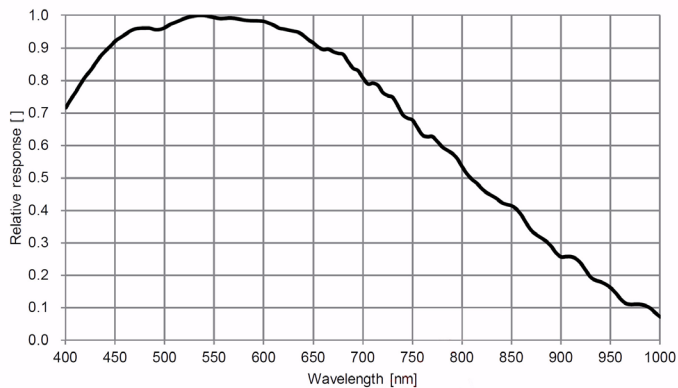

5 MP color

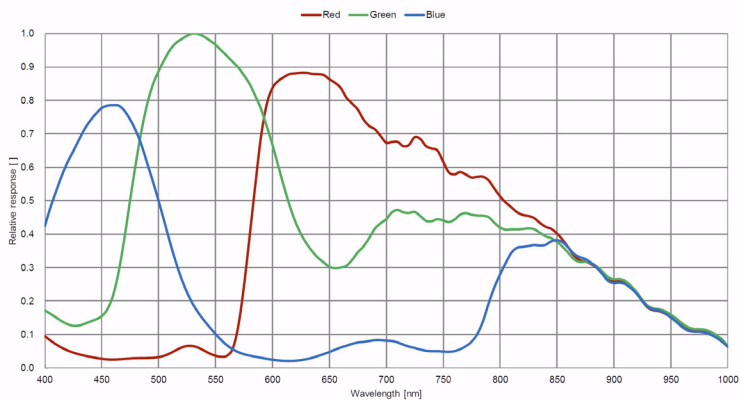

NOTE!



The following points must be observed when using external illumination:

- For color cameras, always use white light illumination.
- For mono cameras, visible or IR light illumination can be used.

3.2 Fields of View (FoV)

The field of view of C Mount cameras depends on the mounted lens. The online Vision Calculator helps you to select the right lens or auto-focus variant.

<https://www.wenglor.com/en/Vision-Calculator/s/Vision+Calculator>

B60x1x1 (B60 AF wide, 1,6 MP)

Camera FoV

Opening angle: 45° x 34,5° x 55,4°

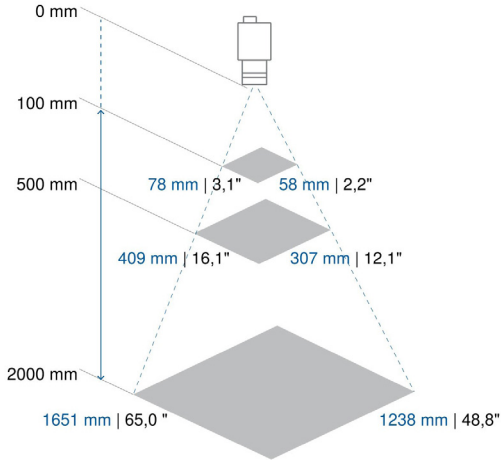

Distance sensor FoV

Opening angle: 45° x 45° x 63° (H x V x D)

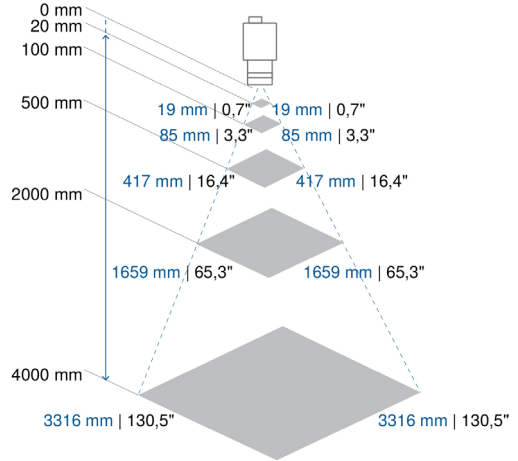

B60x1x2 (B60 AF narrow, 1,6 MP)

Camera FoV

Opening angle: 23,4° x 17,6° x 29,4° (H x V x D)

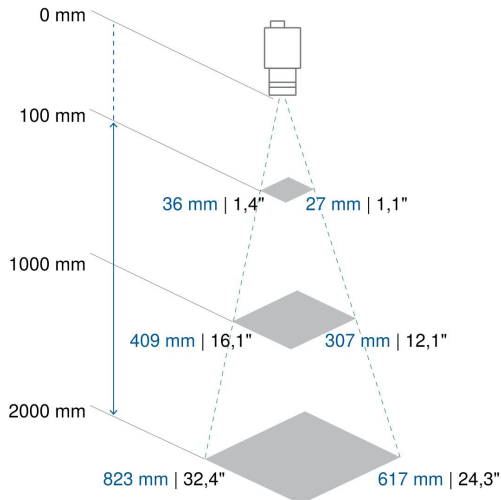

Distance sensor FoV

Opening angle: 45° x 45° x 63° (H x V x D)

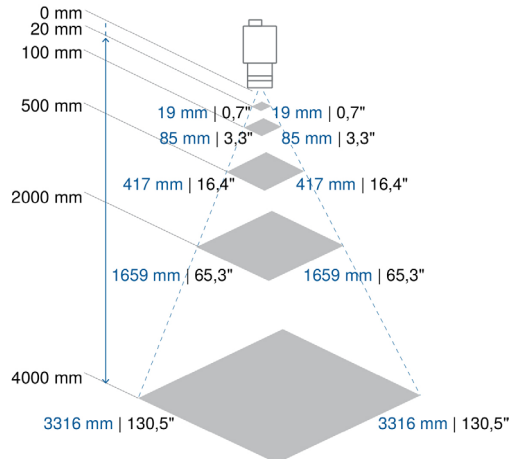

B60x2x1 (B60 AF wide, 5 MP)

Camera FoV

Opening angle: 51,2° x 43,7° x 64,3° (H x V x D)

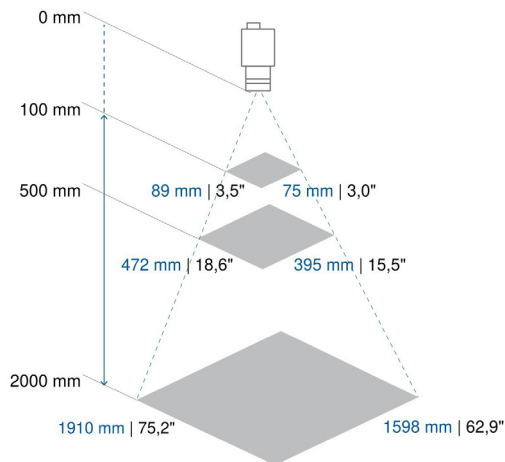

Distance sensor FoV

Opening angle: 45° x 45° x 63° (H x V x D)

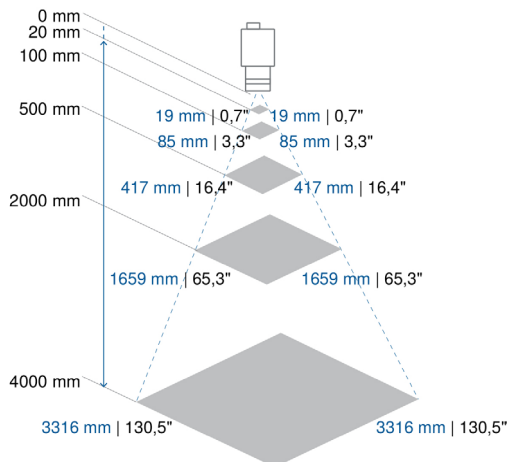

B60x2x2 (B60 AF narrow, 5 MP)

Camera FoV

Opening angle: 21,7° x 18,2° x 28,2° (H x V x D)

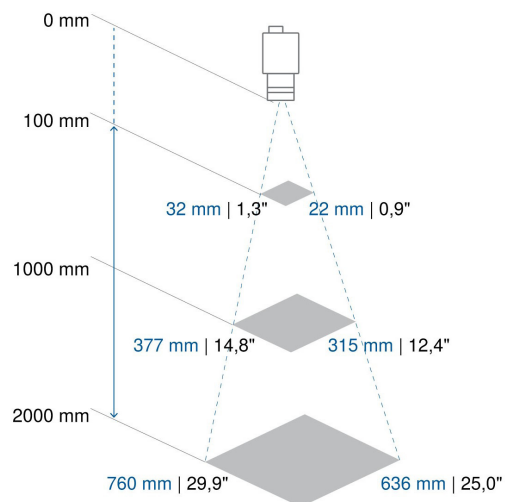

Distance sensor FoV

Opening angle: 45° x 45° x 63° (H x V x D)

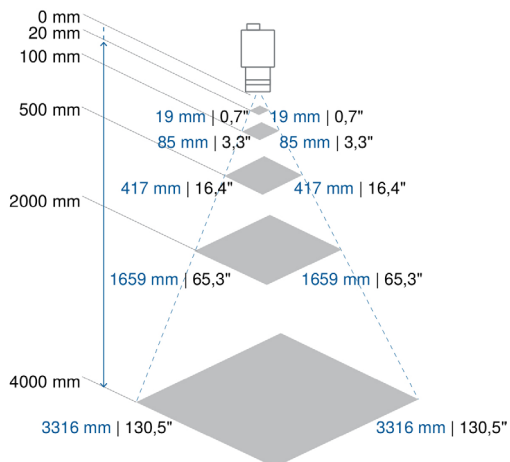

The following diagrams show the definition of the working distance A graphically.

B60 C-Mount

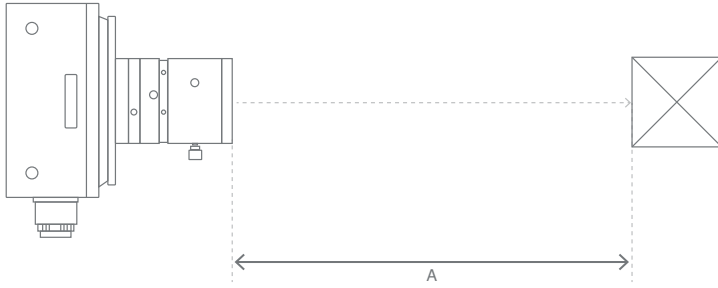

B60 AF

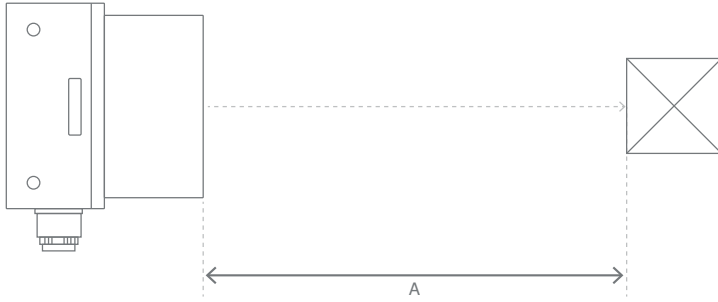

3.3 Dimensional Drawing

All dimensions specified in mm (1 mm = 0.03937")

B60 C-Mount

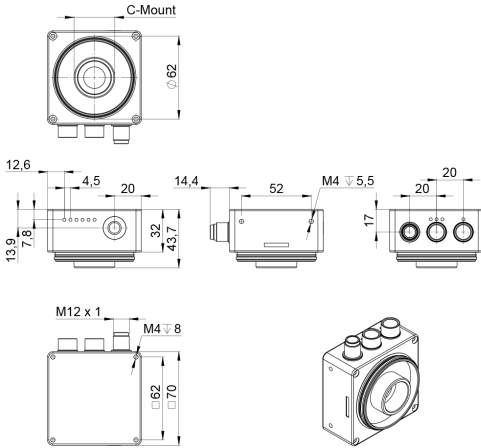

B60 AF

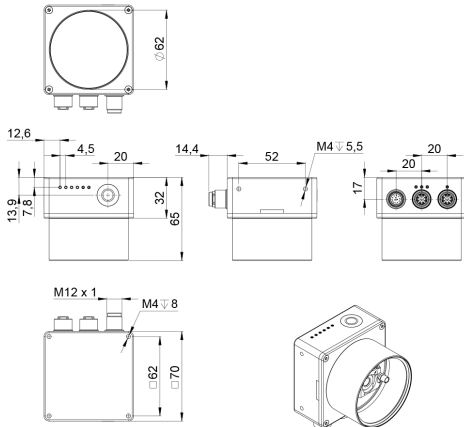

3.4 Connection Diagram

The Smart Camera B60 has 3 separate connectors for parameterization and process data. Power over Ethernet (PoE) is supported via the LAN connector. When using PoE, the digital I/Os are not supported. When using the LAN and Power-I/O connectors at the same time, note that power is supplied via the Power-I/O connector while PoE is disabled.

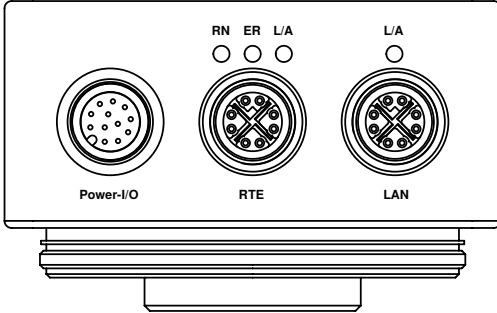

- **Power-I/O** for power supply and digital inputs/outputs
Connection cable with connection diagram no. 1044
M12; 12-pin (A-coded)
- **RTE** for Industrial Ethernet
Connection cable with connection diagram no. 002
M12; 8-pin (X-coded)
- **LAN** for 1Gbit Ethernet (optional: PoE)
Connection cable Connection diagram no. 008
M12; 8-pin (X-coded)

M12; 12-pin (Power-I/O)

Connection Diagram

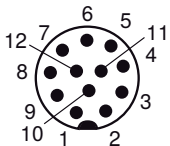
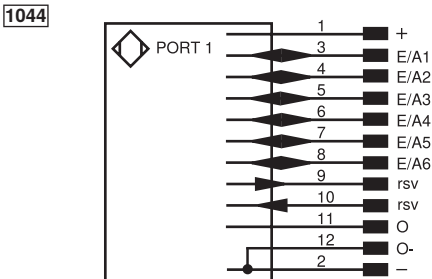

Wire color

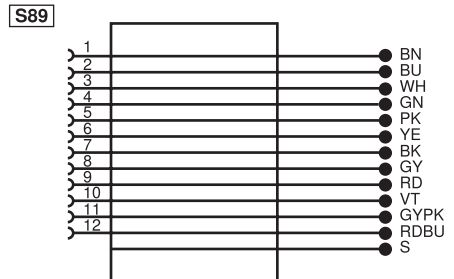

Default settings

Pin	Symbol	default
3	E/A1	Output (PNP, not inverted)
4	E/A2	Output (PNP, not inverted)
5	E/A3	Output (PNP, not inverted)
6	E/A4	Output (PNP, not inverted)
7	E/A5	Output (PNP, not inverted)
8	E/A6	Output (PNP, not inverted)
11	O	Voltage (0-10 V)*

*optional: Current (4-20 mA)

M12; 8-polig (RTE)

Connection diagram

002

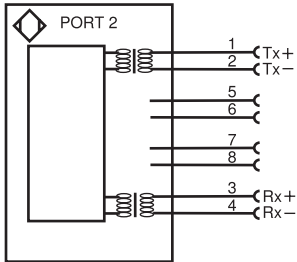

M12; 8-pin (LAN)

Connection diagram

008

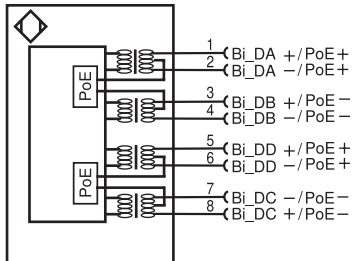

Legend					
+	Supply Voltage +	nc	Not connected	ENBR _{S422}	Encoder B/B̄ (TTL)
-	Supply Voltage 0 V	U	Test Input	ENa	Encoder A
~	Supply Voltage (AC Voltage)	Ū	Test Input inverted	ENb	Encoder B
A	Switching Output (NO)	W	Trigger Input	AMN	Digital output MIN
Ā	Switching Output (NC)	W-	Ground for the Trigger Input	AMAX	Digital output MAX
V	Contamination/Error Output (NO)	O	Analog Output	AOK	Digital output OK
V̄	Contamination/Error Output (NC)	O-	Ground for the Analog Output	SY In	Synchronization In
E	Input (analog or digital)	BZ	Block Discharge	SY OUT	Synchronization OUT
T	Teach Input	AMV	Valve Output	OLt	Brightness output
Z	Time Delay (activation)	a	Valve Control Output +	M	Maintenance
S	Shielding	b	Valve Control Output 0 V	rsv	Reserved
RxD	Interface Receive Path	SY	Synchronization	Wire Colors according to DIN IEC 60757	
TxD	Interface Send Path	SY-	Ground for the Synchronization	BK	Black
RDY	Ready	E+	Receiver-Line	BN	Brown
GND	Ground	S+	Emitter-Line	RD	Red
CL	Clock	≡	Grounding	OG	Orange
E/A	Output/Input programmable	SnR	Switching Distance Reduction	YE	Yellow
 IO-Link		Rx+/-	Ethernet Receive Path	GN	Green
PoE	Power over Ethernet	Tx+/-	Ethernet Send Path	BU	Blue
IN	Safety Input	Bus	Interfaces-Bus A(+)/B(-)	VT	Violet
OSSD	Safety Output	La	Emitted Light disengageable	GY	Grey
Signal	Signal Output	Mag	Magnet activation	WH	White
BI_D+/-	Ethernet Gigabit bidirect. data line (A-D)	RES	Input confirmation	PK	Pink
EN _{S422}	Encoder 0-pulse 0/0̄ (TTL)	EDM	Contactor Monitoring	GNYE	Green/Yellow
PT	Platinum measuring resistor	ENAR _{S422}	Encoder A/Ā (TTL)		

NOTE!

- When connected properly the device status LED pulsates in blue while the smart camera boots. As soon as the smart camera is booted up, the device status LED lights up blue (see section „3.7.3 Device Status LEDs“).
- Switched I/Os are indicated via the I/O-Status LEDs (see section „3.7.1 I/O-Status LEDs“).
- The connection status is indicated via the connector LEDs (see section „3.7.4 Connector LEDs“).



3.5 Complementary Products

You can reach the product page of the B60 Smart Cameras via the link below. From there, navigate to the desired product and the corresponding system components

- Complementary products
- Spare Parts
- Illumination Technology
- Mounting technology
- Connection equipment
- Software

www.wenglor.com/B60

3.6 Construction

3.6.1 B60 C Mount

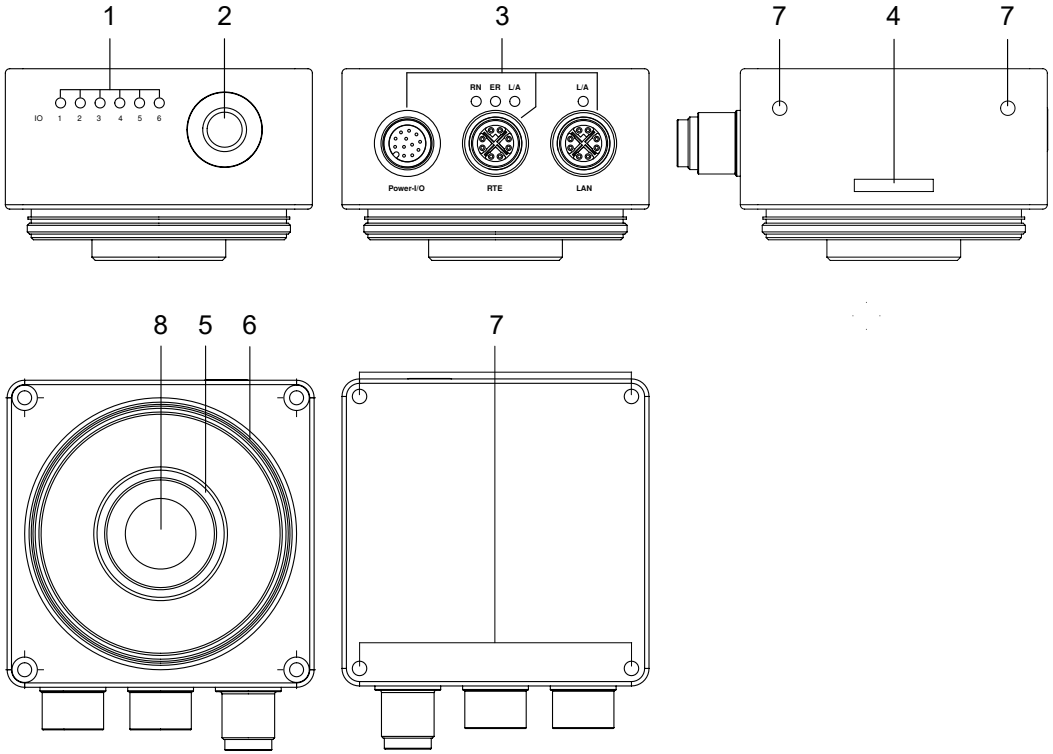

- 1 = I/O-Status LEDs
- 2 = Button
- 3 = Connection plugs
- 4 = Device status LEDs
- 5 = C Mount thread
- 6 = Protective tube thread
- 7 = Mounting holes
- 8 = Image chip

3.6.2 B60 AF

Deviations from B60 C Mount

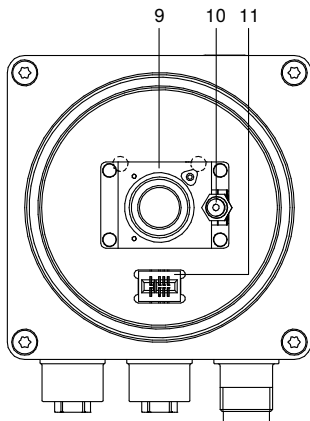

9 = AF module

10 = Laser Pattern

11 = Connector for illumination module

3.6.3 Illumination Module

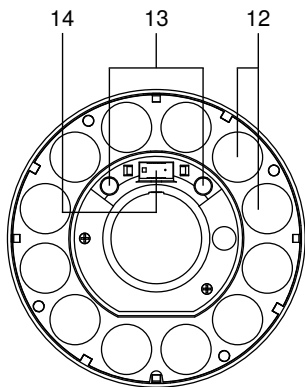

12 = 12 × High-Power LED

13 = Test object status LEDs green, red (for further information see section „[3.7.5 Test Object Status LEDs](#)“)

14 = Multizone Distance Sensor

3.7 Control Panel / Button / Indicator elements

B5

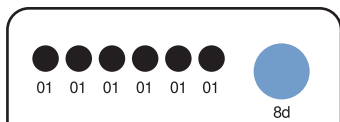

01: LED (I/O Status)

8d: Button

3.7.1 I/O-Status LEDs

LED	State	Function
01	On	I/O HIGH
	Off	I/O LOW



NOTE!

The LED indicates whether the I/O is switched, regardless of Line Format (e.g. PNP, NPN, Pushpull).

3.7.2 Button

The Smart Camera has a button. If you press and release the button on the Smart Camera B60 within the following time period, the following functions are activated. The preview of the device status LED shows which time window is currently active.

Duration	Function	LED State
< 1 second	Triggers data acquisition ¹	-
1...3 seconds	No function	-
3...6 seconds	Activate / Deactivate Localize-Function ²	Preview of Localize (blue blinking slow) or Active (blue on)
6...10 seconds	No function	-
10...15 seconds	Network reset of LAN Interface	Blue blinking fast
> 15 seconds	No function	-

¹ Make sure that the trigger mode is enabled and the trigger source is set to software (see operating instructions of [DNNF023](#)).

² When the Localize function is activated, the corresponding device is highlighted in the Software wenglor weHub (see operating instructions of [DNNF024](#)) and on the device website (see section „7.8 Device Status“) in order to ensure clear assignment in the case of multiple devices in the network. The corresponding device emits a visual signal (device status LEDs blink blue on both sides). Deactivate Localize via pressing again the button on the device. Activating and deactivating Localize is also possible via the software wenglor weHub. At B60 Smart Cameras with auto-focus, the laser pattern is shown additionally if localize is active. Activating or deactivating the laser pattern and enabling or disabling the synchronization of the laser pattern with the localize function is possible on the device website (see section „7.7.4 Laser Pattern“).

**NOTE!**

The functionality of the button can be disabled on the device website so that unwanted actions triggered by the button are avoided (see section „7.7.1 Button“).

3.7.3 Device Status LEDs

The Smart Camera has (two) LED strips on both sides to display the current device status. The device status is additionally displayed in the software wenglor weHub and on the device website (see section „7.8 Device Status“).

Status options:

LED color	State	Function status
Blue	On Blinking Pulsating	Active (Running) Localize active Booting
Yellow	Blinking	Warning (e.g. too big changes in position)
Red	Blinking	Error (e.g. crashed software service or blocked auto-focus module)

Details of warnings and errors:

Message	Level	Description
High CPU load	Warning	Active in case of high CPU load. Check the device website (Diagnosis).
High RAM	Warning	Active in case of high RAM. Check the device website (Diagnosis).
High storage usage	Warning	Active in case of high storage usage. Check the device website (Diagnosis).
High LAN Ethernet	Warning	Active in case of high LAN Ethernet. Check the device website (Diagnosis).
High temperature	Warning	Active in case of high temperature. Check the device website (Diagnosis).
Too big changes in position	Warning	Active in case of unwanted position changes. Check the device website (→ Settings → Position Sensor).
Too high acceleration	Warning	Active in case of too big acceleration values. Check the device website (→ Settings → Position Sensor).
CPU throttling	Warning	Active in case of CPU throttling because of too high CPU temperature. Check the device website (Diagnosis).
Storage end of life	Warning	Active in case of storage end of life. Check the hardware.
Autofocus module error	Error	Active in case of any autofocus module error (e.g. blocked autofocus module). Check the hardware or reboot the device.

Message	Level	Description
Crashed software service	Error	Active in case of any crashed software service. Check the device status in the weHub software, check the device website for details (if available) or reboot the device.
Crashed RTU	Error	Active in case of crashed RTU. Reboot the device.
Uncalibrated analog output	Error	Active in case of uncalibrated analog output. Check the hardware.
Distance sensor	Error	Active in case of an error at the distance sensor. Check the hardware.

3.7.4 Connector LEDs

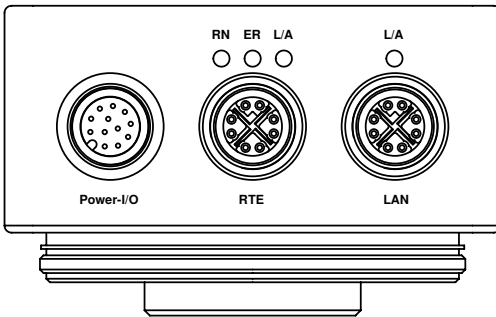

LED	Color	State	Function status
L/A	Orange	On Blinking Off	Ethernet connection available Smart Camera sends/receives Ethernet frames No Ethernet connection available



NOTE!

For details about the LEDs at the RTE connector, check the separate interface protocol for Industrial Ethernet ([DNNF023](#)).

3.7.5 Test Object Status LEDs

The test object status LEDs (green/red) can be configured in the wenglor uniVision software and linked to e.g. good/bad results (only available for auto-focus devices if the illumination module is used).

3.7.6 Visual Field Marking (Laser Pattern)

The visual field marking (only available for auto-focus devices) is used for initial alignment during installation. The marking can be activated/deactivated using the button (see section „3.7.2 Button“) and provides an indication of the camera's field of view in the following areas:

- B60 AF wide (B60xxx1): 100...1000 mm / exact image center at 200 mm
- B60 AF narrow (B60xxx2): 200...1000 mm / exact image center at 400 mm

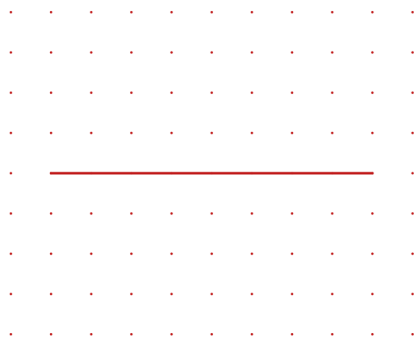

NOTE!



- The laser points cover approximately 2/3 of the real field of view at the specified distances, so that the test object is safely within the field of view in the specified areas.
- Observe the warnings (see section „2.4 LED/Laser Warnings“).
- Activating or deactivating the laser pattern and enabling or disabling the synchronization of the laser pattern with the localize function is possible on the device website (see section „7.7.4 Laser Pattern“).

3.8 Heat sink

NOTE!

The heat sink improves heat dissipation and is attached to the back of the B60 using 4 screws.



It is particularly recommended for

- 5MP (color) devices
- high frame rate/CPU/RAM utilisation (e.g. when using Module Image Deep OCR in the uniVision job)

3.9 Scope of Delivery

C Mount devices:

- B60 in ordered variant; Depending on the license package, corresponding licenses are active
- Commissioning Instructions
- General Safety Precautions

AF devices:

- B60 in ordered variant; Depending on the license package, corresponding licenses are active
- Commissioning Instructions
- General Safety Precautions
- Protective tube IP67

NOTE!



- All currently associated software modules can be found at
 - » [Product Highlights of uniVision 3](#)
- Mounting screws are not included in the scope of delivery.
- Z60K heat sinks and Z60F illumination modules are not included in the scope of delivery and must be ordered separately.

4. Transport and Storage

4.1 Transport

Upon receipt of shipment, the goods must be inspected for damage in transit. The manufacturer must be informed without delay concerning damage to the package. When returning the package, clear indication of transport damage must be attached.

4.2 Storage

The following points must be taken into consideration with regard to storage:

- Do not store the product outdoors.
- Store the product in a dry, dust-free place.
- Protect the product against mechanical impacts.
- Protect the product against exposure to direct sunlight.
- Observe storage temperature.



ATTENTION!

Risk of material damage if not stored properly!

Damage to the product possible.

- Observe storage regulations.
-

5. Installation and Electrical Connection

5.1 System overview

The current system overview is located at [B60 System Overviews](#)

5.2 Mounting and General Installation Instructions



ATTENTION!

Danger of material damage in case of improper installation!

Damage to the product possible.

- Observe mounting instructions.
-



CAUTION!

Risk of personal injury and damage to property during installation!

Damage to personnel and product possible.

- Ensure a safe installation environment.
-

- Protect the product from contamination during assembly.
- Observe electrical and mechanical regulations, standards, and safety rules.
- Make sure that the Smart Camera is mounted firmly and securely.
- The Smart Camera must be protected against mechanical influences.
- The Smart Camera should not be subjected any vibration because this could influence image acquisition.
- The power supply should be connected directly and it should be as short as possible:
 - » max. cable length Power-I/O: 30 m
 - » max. cable length RTE/LAN: 30 m
- Torques must be observed (see section „5.2.3 Tightening Torques“)
- Adequate heat dissipation must be assured for the device. This can be accomplished, for example, by means of a metallic connection between the Smart Camera housing and the mounting base or by using the heat sink.
- The Smart Camera needs approx. 30 sec. to boot.

Use only standard accessories for mounting the products (see product detail page).

Use mounting adapters for illuminations to attach the B60 directly to external illuminations and aluminium profiles.

5.2.1 Cable Outlet with Angled Plugs

The following diagram shows the cable outlet on the Smart Camera when using angled wenglor connection cables:

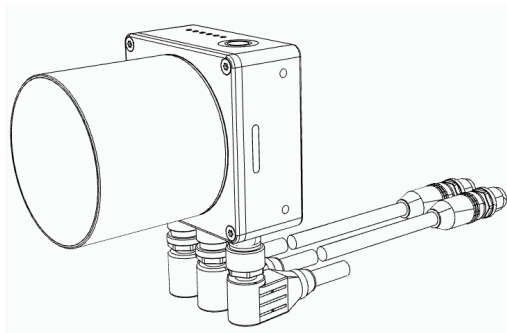

5.2.2 Mounting option for Robot Vision with Universal Robots (UR)

To attach the B60 to a Universal Robot, use ZVZC001. For camera and robot calibration, this adapter is also used to attach a ZVZJ* calibration plate to the robot.

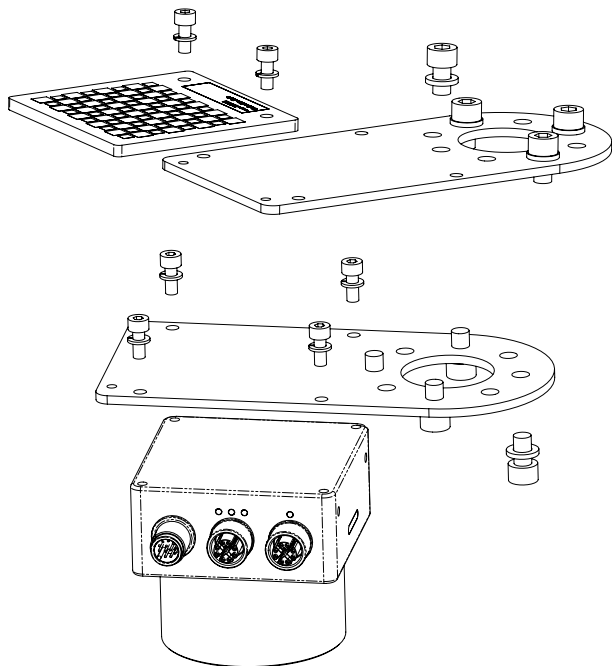

5.2.3 Tightening Torques

The following table defines the tightening torques of the connectors and mounting options to ensure compliant and fault-free operation:

Connection type / mounting holes	Tightening torque in (Nm)
M12, 12-pin	0,6
M12, 8-pin	0,4
Mounting holes	1

5.2.4 Assembly of Illumination Modules

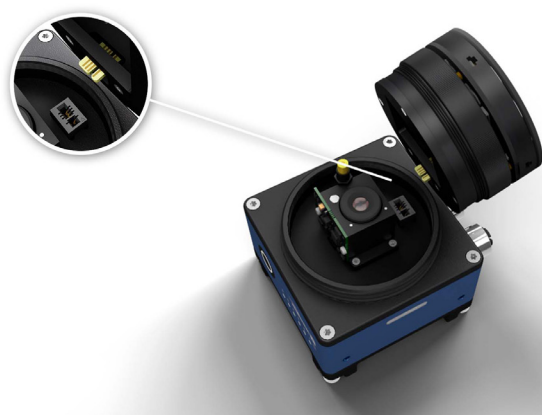

- Unscrew the protective tube
- Screw on the illumination module hand-tight (make sure that the plug is correctly aligned, see illustration above)
- Attach optional magnetic filters
- Screw the protective tube back on hand-tight to maintain degree of protection.



NOTE!

The illumination brightness can be adjusted in the wenglor uniVision software (see operation instructions of [DNNF023](#)).



ATTENTION!

Danger of material damage due to improper installation.

Damage to the product possible.

- Only install/dismantle lighting modules when they are deenergized
- Only the illumination modules intended by wenglor for this product may be used.

5.2.5 Assembly of Filters on Illumination Modules

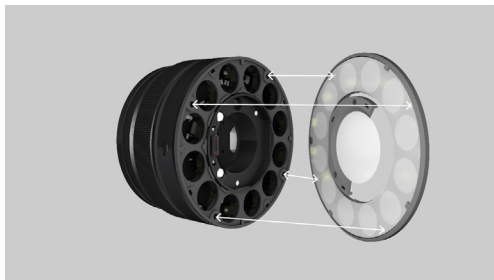

NOTE!



- Filters for B60 auto-focus adhere magnetically to the lighting module.
- Place carefully (using tweezers if necessary).
- Take care not to contaminate the filter foil during installation.
- In the event of contamination, cleaning with a microfiber cloth is recommended.

5.3 Electrical Connection

Depending on the usage only one or two connections are needed. Connect the Smart Camera to 24 V DC ($\pm 10\%$). Alternatively, PoE functionality can be used via the LAN connector (e.g. using a PoE switch) (see section „3.4 Connection Diagram“).

Connect the connection cable (network cable) of the LAN port to your PC for configuration via the uniVision software or to a switch to merge multiple devices (e.g. robots from UR).

The Smart Camera can also be powered directly from the robot's I/Os.

Network overview example:

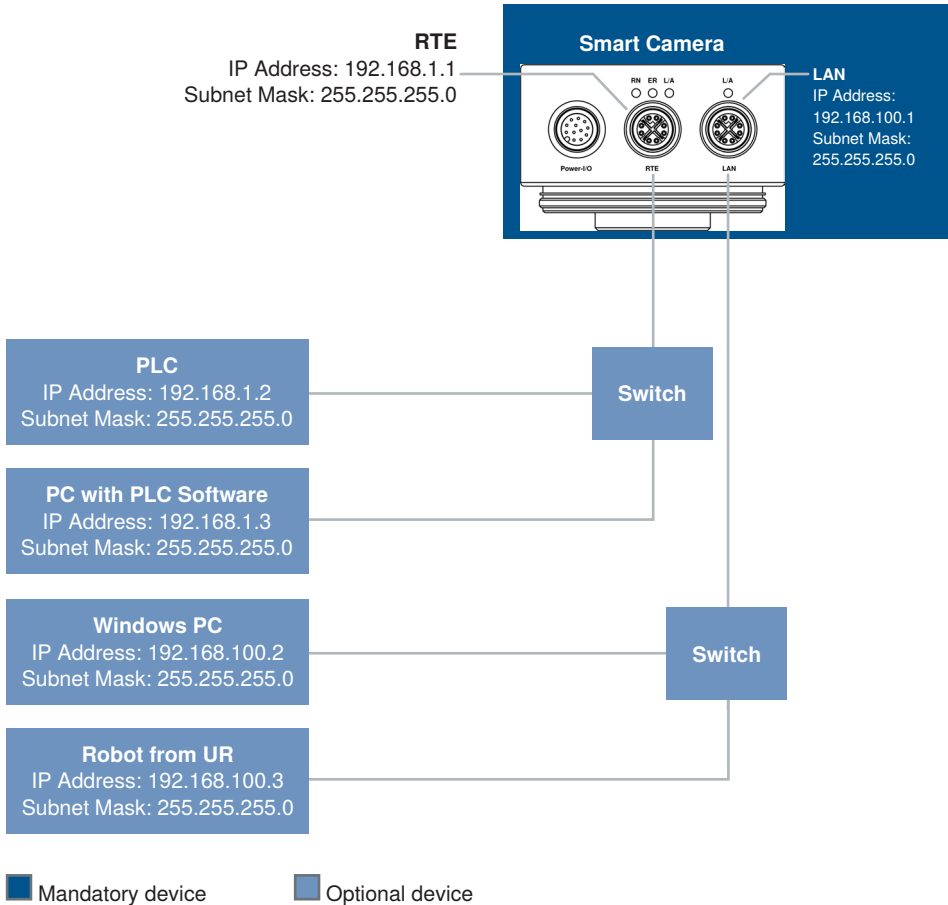

NOTE!

Suitable connection lines and connection cables can be found on the product details page.



DANGER!

Risk of personal injury or property damage due to electric current.
Voltage-carrying parts may cause damage to personnel and equipment.

- Appropriately, qualified personnel may only connect the electrical device.



ATTENTION!

Malfunctions in operation and defects in the device or the system due to improper wiring

- Improper wiring can lead to malfunctions during operation and to defects.
- Follow the wiring instructions exactly.

5.4 Connection to External Illumination and Trigger Sensor

For L* Lights:

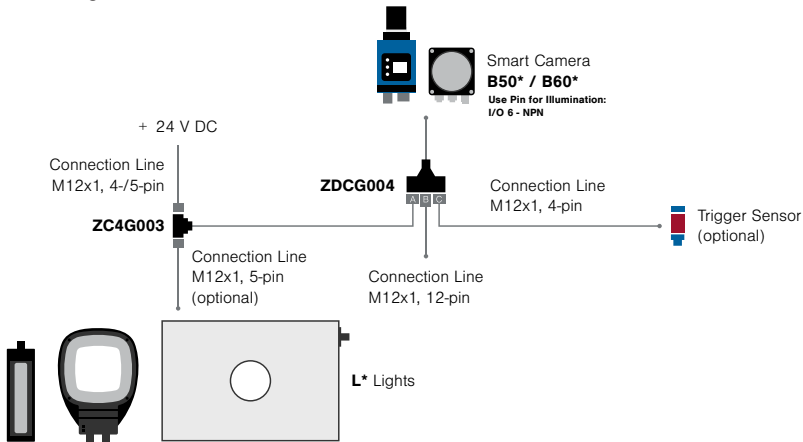

For ZVZF* Lights:

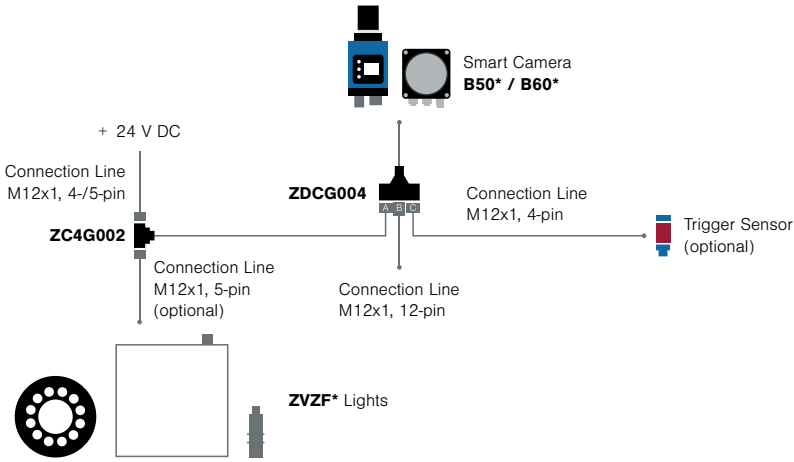

How to set up:

- Connect as described above
- Parameter settings in the software wenglor uniVision (**changes to default**):

Module Application	Property	Value
Smart Camera - Digital I/O control	Line Selector	Line 6
	Line Mode	Output
	Line Inverter	<input checked="" type="checkbox"/>
	Line Format	Push Pull
	Line Source	Exposure Active

- If the optional trigger sensor is also used, please also note the following parameter settings in uniVision (**changes to default**):

Module Application	Property	Value
Smart Camera - Acquisition Control	Trigger Selector	Exposure Start
	Trigger Mode	On
	Trigger Source	Line 5



NOTE!

By setting e.g. "Line 5" as trigger source, automatically the corresponding Line Mode in Digital I/O Control is set to "Input".

- In order to use the dimming function of external illumination L, please also note the following parameter settings in uniVision (**changes to default**):

Module Application	Property	Value
Smart Camera - Digital I/O control	Analog Output	On
	Analog Output Controller	Voltage
	Analog Value [%]	100*

* Select desired output value (see operating instructions of illumination)



NOTE!

For details, see operating instructions of the illumination.

Manual wiring:

Connection overview with external illumination ZVZF1 / ZVZF2 / ZVZF3 / ZVZF4

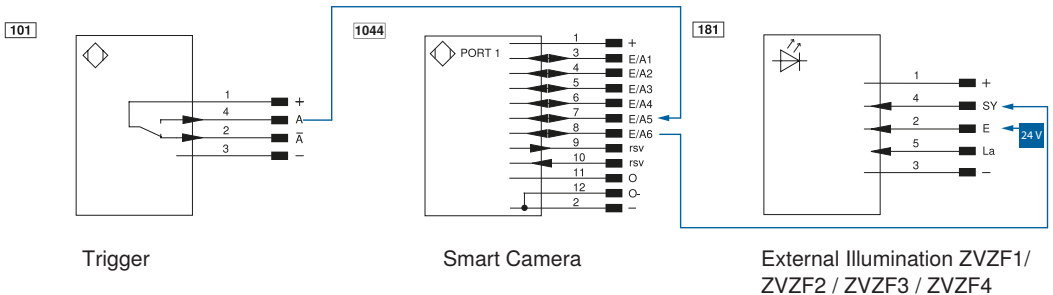

NOTE!

Wiring of Smart Cameras and illumination is valid for wglor illumination with order numbers ZVZF1xx, ZVZF2xx, ZVZF3xx and ZVZF4xx.

- Pin 2 (E) must be connected to 24 V DC at the illumination in order to activate the strobe mode.

Connection overview with external illumination L

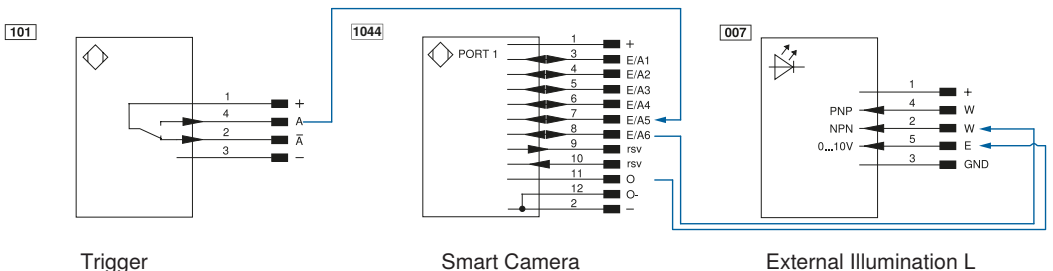

**NOTE!**

In order to use the dimming function of external illumination L, connect pin 12 (O-) of the Smart Camera with ground and pin 11 (O) of the Smart Camera with pin 5 of the external illumination L. See table above for uniVision parameter settings (changes to default).

5.5 Adjusting LAN Network Settings

In TCP/IP networks the devices must be in the same network to communicate. It can be that either the Smart Camera or the customer PC must be configured to ensure this.

**NOTE!**

Use the software wenglor weHub (see section „6. Software wenglor weHub“) to adjust the network settings of the B60 Smart Camera.

5.5.1 Manual LAN Network Settings

Upon shipment from the factory, the default LAN network settings of the Smart Camera are:

- IP address: 192.168.100.1
- Subnet mask: 255.255.255.0
- Gateway: 0.0.0.0

In order to be able to connect the Smart Camera to your PC, you have to make sure that the Smart Camera and your PC are both within the same IP address range.

Address format for IP addresses (IPv4)

	Network part	Device part (host part)
IP address	192.168.100.	001
Subnet mask	255.255.255.	000

The network part of the Smart Camera's IP address must coincide with the network part of PC's IP address, but the device part of the address must be different for the Smart Camera and the PC. By default, the IP address of the network adapter card in the PC is set to dynamic (automatic allocation). Change the setting to "static". The IP address must differ from the Smart Camera IP and must be unique in the network, e.g. 192.168.100.100.

**NOTE!**

See the manual of your operating system for more information on how to adjust the IP address.

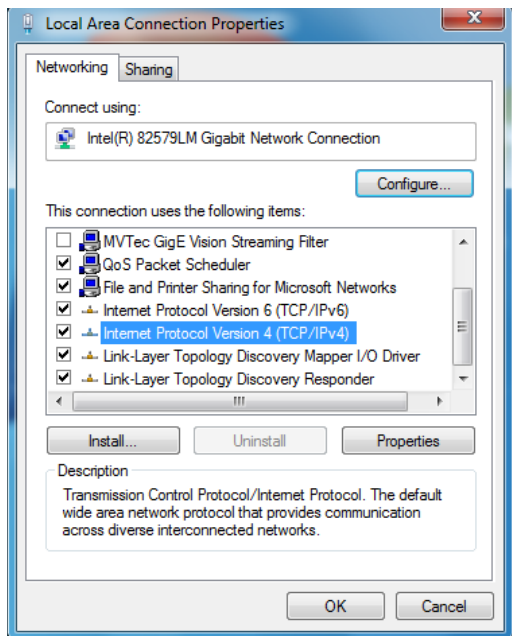

Fig. 1: Local connection properties

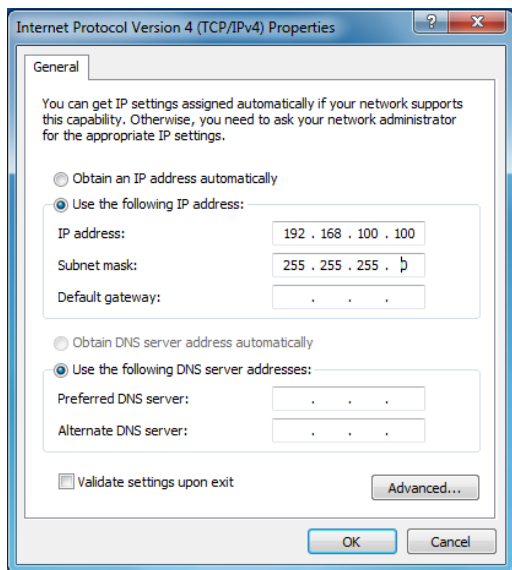

Fig. 2: Properties of internet protocol

The integrated web server can then be accessed containing all global device settings (see section „7. Device Website“).

5.5.2 Test Connection between Smart Camera and PC

To test the connection between Smart Camera and PC following should be done:

- Ensure that power and LAN connection is available and wait until booting as been finished completely.
- Check LEDs
 - » Device status LEDs → blue on
 - » L/A LED → on or blinking
- Open browser and type the Smart Camera IP address (factory settings 192.168.100.1) into the browser address field. The web page should be available. If the web page is not reachable check all settings and retry.

6. Software wenglor weHub

The software wenglor weHub can be installed on any Windows 10 (22H2) and 11 (22H2) PC for finding B60 Smart Cameras, for setting up the network configuration of B60 Smart Cameras and for accessing the device website. For more information, see: <https://www.wenglor.com/p/DNNF024>

7. Device Website

Access the device website via entering directly the IP address of the LAN Ethernet adapter in any supported browser (default address: 192.168.100.1).

NOTE!

- Cabling must be capable of 1 GBit/s throughout the entire network.
- Make sure that the network settings of the LAN Ethernet adapter of the Smart Camera and the PC fit together. Use a unique network configuration for the LAN Ethernet adapter of the B60 within the LAN network.
- Keep the networks for LAN and RTE separated in order to optimize the performance of the Smart Camera.
- The following IP addresses are reserved and not allowed at the LAN port of the Smart Camera:
 - » 0.0.0.0/8
 - » 1.0.0.0/8
 - » 127.0.0.0/8
 - » 224.0.0.0/4
 - » 233.252.0.0/24
 - » 240.0.0.0/4
 - » 255.255.255.255/3
- Use the software wenglor weHub to find B60 Smart Cameras, to adjust the LAN Ethernet settings and to access the device website. For details, check the operating instructions of the software wenglor weHub ([DNNF024](#)).



Supported minimum browser versions (tested on Windows 10 (22H2) and Windows 11 (22H2) PCs):

- Chrome 108
- Firefox 108
- Microsoft Edge 108
- Chromium 111

7.1 Structure of Device Website

The device website is divided into several areas:

- (1) Tabs
- (2) Icon menu bar
- (3) Workspace
- (4) Side navigation
- (5) Help button (see section „7.9 Help Button“)

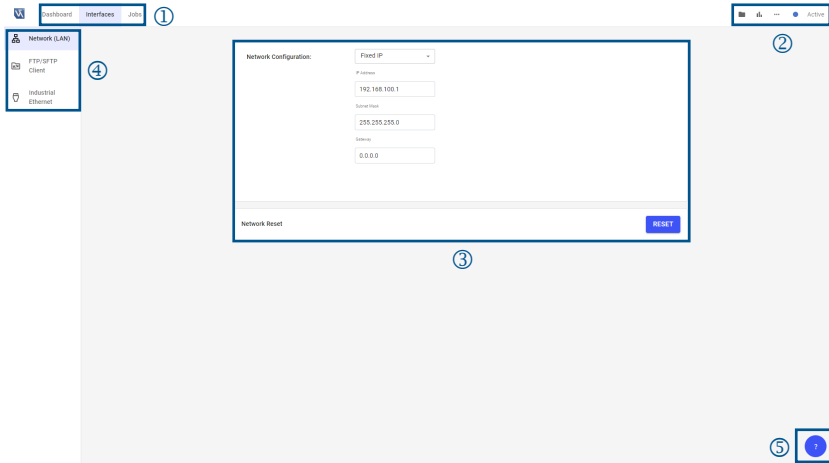

7.2 Dashboard

By default, the tab “Dashboard” shows the details of the B60 Smart Camera.

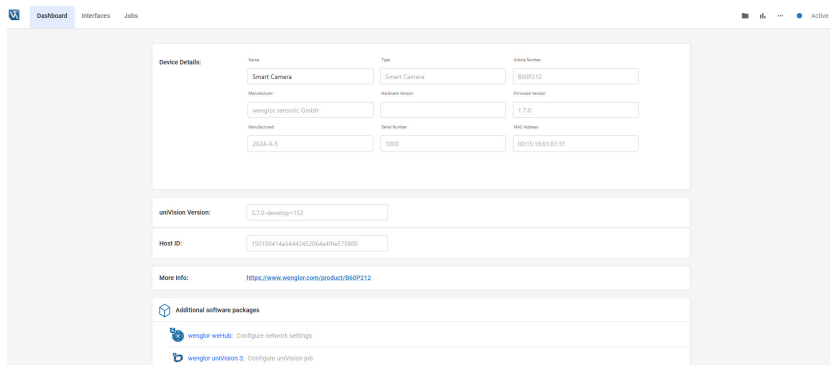

The screenshot shows a web interface for the B60 Smart Camera. At the top, there are navigation tabs: "Dashboard" (selected), "Interfaces", and "Jobs". The main content area is titled "Device Details" and contains a table of information:

Name	Type	Article Number
Smart Camera	Smart Camera	860P212
Manufacturer	Hardware Version	Firmware Version
wenglor sensoric GmbH		3.7.0
Manufactured	Data Number	MAC Address
2024-4-5	1000	00:15:18:01:81:31

Below the table, there are three input fields:

- uniVision Version: 3.7.0-develop+152
- Host ID: 10010041f4c34454512056a4994275950
- More info: <https://www.wenglor.com/products/860P212>

At the bottom, there is a section titled "Additional software packages" with two links:

- wenglor wehkl: Configure network settings
- wenglor uniVision 3: Configure uniVision job

Adjust the name, if needed (limited to 63 characters).

The uniVision version of the device shows which version of the software wenglor uniVision 3 on the PC can connect to the device.

NOTE!



- The first two digits of the uniVision version of the device and the software wenglor uniVision 3 on the PC must fit together in order to connect (e.g. uniVision version 3.0.0 on B60 is compatible with software wenglor uniVision 3.0.0 on PC).
- For details about compatibility between firmware and uniVision version, see the release notes and the operating instructions of the software wenglor uniVision 3 ([DNNF023](#)).

The host ID is a device specific identifier. It is helpful for HALCON script users in order to execute a HALCON script only on one specific device (for individual licensing). For details, see uniVision operating instructions ([DNNF023](#) → Module HALCON Script).

“More info” opens a new tab in the browser with the product detail page on the wenglor website (only available with internet access).

The section “Additional software packages” provides direct links to download further software products.

7.3 Interfaces

Open the tab “Interfaces” to see and edit all interface settings.

7.3.1 Network (LAN)

In the side navigation “Network (LAN)” it is possible to adjust the LAN network configuration of the B60 Smart Camera.

The screenshot shows the 'Network Configuration' page in a web interface. On the left, there is a sidebar with 'Network (LAN)' selected. The main content area has a 'Network Configuration' section with a 'Fixed IP' dropdown menu. Below it are three input fields: 'IP Address' containing '192.168.100.1', 'Subnet Mask' containing '255.255.255.0', and 'Gateway' containing '0.0.0.0'. At the bottom of the configuration area, there is a 'Network Reset' button.

Configuration for LAN network:

- Fixed IP: Set fix IP address, subnet mask and gateway of the B60 Smart Camera.
- Obtain IP: DHCP server in the network can assign network settings automatically to the B60 Smart Camera

NOTE!

- Cabling must be capable of 1 GBit/s throughout the entire network.
- Use a unique network configuration for the LAN Ethernet adapter of the Smart Camera within the LAN network.
- Keep the networks for LAN and RTE separated in order to optimize the performance of the Smart Camera.
- The following IP addresses are reserved and not allowed at the LAN port of the Smart Camera:
 - » 0.0.0.0/8
 - » 1.0.0.0/8
 - » 127.0.0.0/8
 - » 224.0.0.0/4
 - » 233.252.0.0/24
 - » 240.0.0.0/4
 - » 255.255.255.255/3
- Confirm the reboot info to start the network change. During the network change, a software reboot is done automatically.
- If there is no DHCP server in the network, the B60 Smart Camera will start after a certain time with a backup network configuration.
- After network changes, enter the new IP address in the browser or open the software wenglor weHub in order to find the device again (for details, see operating instruction of software wenglor weHub [DNNF024](#)).



“Network reset” resets the network configuration of the device to its defaults:

- IP address: 192.168.100.1
- Subnet mask: 255.255.255.0
- Gateway: 0.0.0.0



NOTE!

Confirm the reboot info to start the network reset. During the network reset, a software reboot is done automatically.

7.3.2 FTP/SFTP Client

Adjust the side navigation “FTP/SFTP Client” to store data of Device FTP on an external FTP or SFTP server in the network (e.g. on the PC).

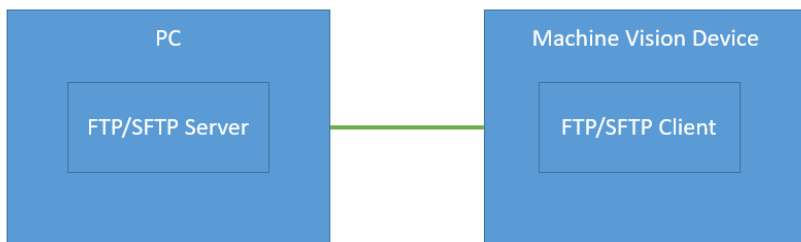

Settings:

- Select the protocol FTP or SFTP
- Enter the IP address of the device where the FTP/SFTP server is running on (e.g. the PC)
- Enter the username and password of the FTP/SFTP server

NOTE!



- Password is only visible if authentication is deactivated or, in case of activated authentication, if user of user group admin or admin (default) is logged in.
- For details about process data via Device FTP, see operating instruction of the software wenglor uniVision 3 [DNNF023](#).

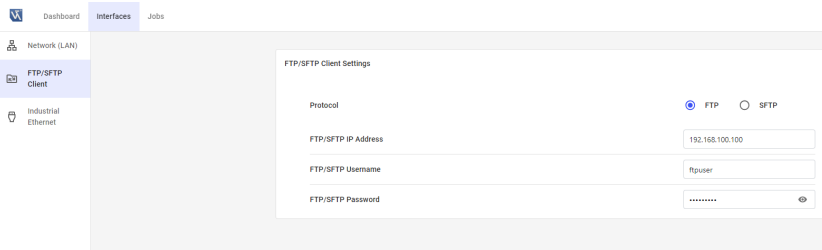

7.3.3 weHub Server

Adjust the side navigation “weHub Server” in order to adjust the weHub server settings.

- weHub Server: Activate or deactivate the weHub Server (by default activated). A connection from the weHub client software is only possible, if the weHub Server on the Machine Vision Device is active. Maximum one connection is possible to the weHub Server on the Machine Vision Device.
- weHub Connection Status: Shows if any weHub client software is connected to the weHub Server on the Machine Vision Device or not.
- Connected from weHub software (client): Shows the IP address of the device where the weHub client software runs if it is connected to the Machine Vision Device.

NOTE!



- Download and install the software wenglor weHub from the wenglor website ([DNNF024](#)). Activate the slider “Auto connect weHub to device” at the device in order to connect to the weHub server on the Machine Vision Device.
- Connecting from the weHub software to Machine Vision Devices allows to directly upload images to AI Lab and to directly download models from AI Lab for Module Image AI within the uniVision job. For details, see [DNNF023](#) and the Getting Started documentation for the AI Loop.

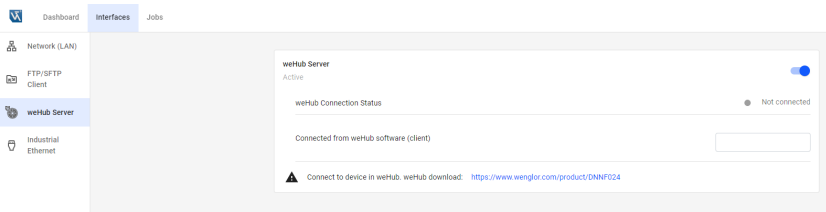

7.3.4 Industrial Ethernet

Adjust the side navigation “Industrial Ethernet” in order to communicate via Industrial Ethernet (e.g. PROFINET) to communication partners via the RTE connector of the Machine Vision Device.

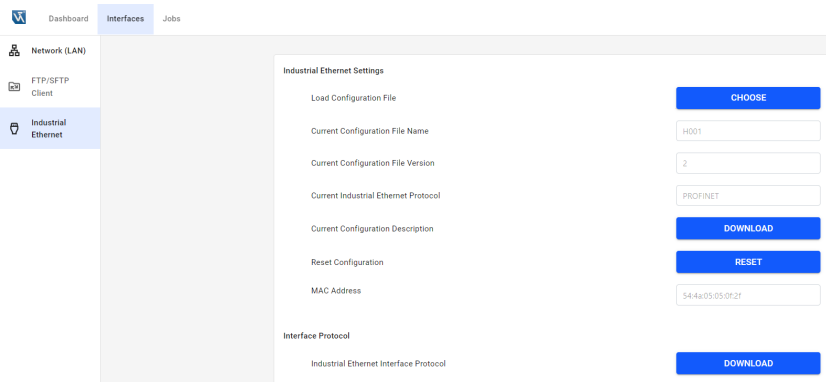

The following options are available:

- Load Configuration File: Enables to load a different configuration file for the user-defined process data.
- Current Configuration File Name: Shows the current name of the configuration file.
- Current Configuration File Version: Shows the current version of the configuration file.
- Current Industrial Ethernet Protocol: Shows the current Industrial Ethernet protocol (e.g. PROFINET).
- Current Configuration Description: Opens a separate tab with the description of the current configuration.
- Reset Configuration: Resets the configuration file to the default configuration (H001). Resetting the configuration file requires a device reboot.
- MAC Address: Shows the MAC Address of the RTE connector (in order to identify the device if using BootP at EtherNet/IP).
- Industrial Ethernet Interface Protocol: Open a separate tab with the interface protocol for Industrial Ethernet.



NOTE!

For details, see interface protocol [DNNF023](#).

7.3.5 NTP Client

Adjust the sidebox “NTP Client” in order to connect to a NTP server in the LAN network. By default, the NTP client is deactivated and the current date and time is displayed.

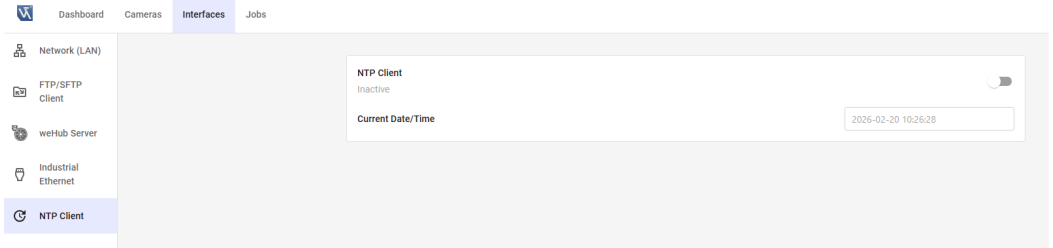

Activate the NTP client in order to connect to a NTP server in the LAN network.

- NTP Server: Enter the IP address of the device where the NTP server runs on (e.g. PC).
- Timezone: Select the relevant timezone.
- In Sync: Returns if the current date and time are in sync with the NTP server or not.

The screenshot shows a web dashboard with a sidebar on the left containing icons for Network (LAN), FTP/SFTP Client, weHub Server, Industrial Ethernet, and NTP Client. The main area is titled 'Interfaces' and contains the 'NTP Client' configuration panel. The panel shows the NTP Client is 'Active' with a blue toggle switch. Below this, the 'Settings' section includes: 'NTP Server' with a text input field containing '192.168.100.104'; 'Timezone' with a dropdown menu set to 'Europe/Berlin'; 'In Sync' with a blue dot and the text 'In Sync'; and 'Current Date/Time' with a text input field containing '2026-02-20 10:27:04'.

NOTE!



- The synchronization of date and time can take up to one minute.
- Make sure to run a NTP server in the LAN network that is accessible by the device. For example, enable the NTP server that is available on Windows 11 PCs via opening the registry editor. Set Enabled to 1 at "HKLM\System\CurrentControlSet\Services\W32Time\TimeProviders\NtpServer"

The screenshot shows the Windows Registry Editor window titled 'Registrierungs-Editor'. The address bar shows the path: Computer\HKEY_LOCAL_MACHINE\SYSTEM\CurrentControlSet\Services\W32Time\TimeProviders\NtpServer. The left pane shows a tree view with the 'NtpServer' key selected. The right pane displays a list of registry values:

Name	Typ	Daten
(Standard)	REG_...	(Wert nicht festgelegt)
AllowNonstandardModeCombinations	REG_...	0x00000001 (1)
ChainDisable	REG_...	0x00000000 (0)
ChainEntryTimeout	REG_...	0x00000010 (16)
ChainLoggingRate	REG_...	0x0000001e (30)
ChainMaxEntries	REG_...	0x00000080 (128)
ChainMaxHostEntries	REG_...	0x00000004 (4)
DllName	REG_...	%systemroot%\system32\w32time.dll
Enabled	REG_...	0x00000001 (1)
EventLogFlags	REG_...	0x00000000 (0)
InputProvider	REG_...	0x00000000 (0)
RequireSecureTimeSyncRequests	REG_...	0x00000000 (0)

7.4 Jobs

Open the tab “Jobs” in order to see and edit the uniVision job settings.

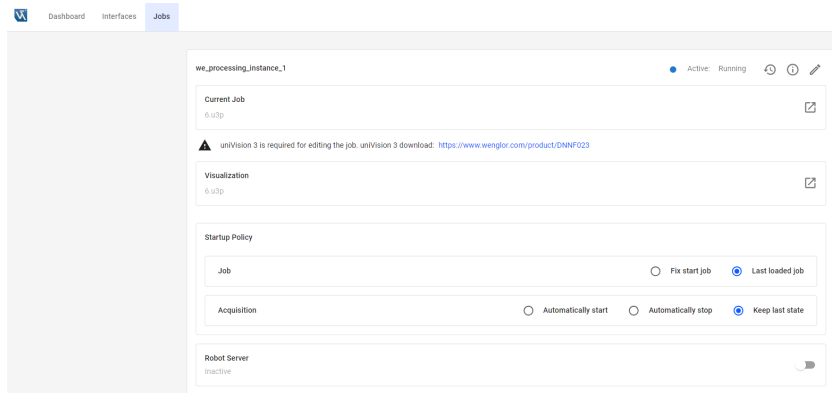

It is possible to edit the name of the processing instance and to show the available network ports. Furthermore, it is possible to see the current status of the Processing Instance and to download the history of the maximum 50 last warnings or errors that happened after booting (warnings and errors are not kept at reboots of the device or the Processing Instance).



NOTE!

For details about the different ports and the warnings and errors of the processing instance, see operating instruction of software wenglor uniVision 3 [DNNF023](#).

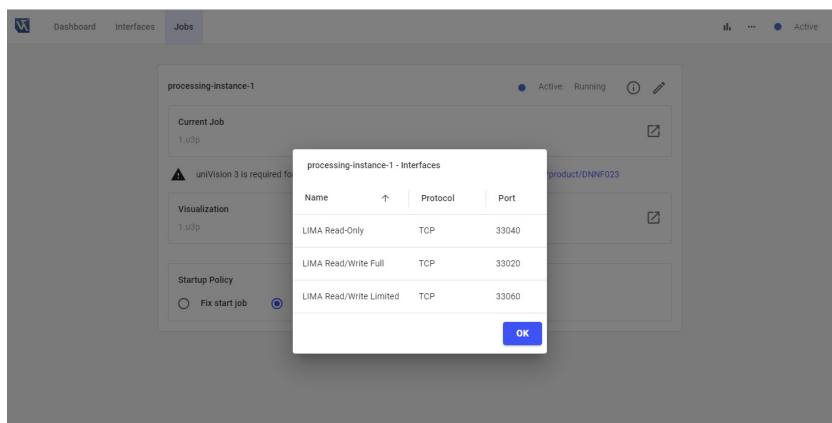

By default, the Smart Camera boots with the last loaded job. If no job is available, it boots with an empty (un-defined) job. It is also possible to select one specific fix start job of the project folder on the device.



NOTE!

Upload or download of uniVision jobs is possible via File Management (see section „7.5 File Management“).

By default, the Machine Vision Device keeps the last acquisition status after booting. It is possible to select the option to automatically start or stop the acquisition after booting.



NOTE!

Active acquisition means that the device is ready to receive trigger signals.

By default, the robot server is activated. Deactivate it, if the communication to robots is not needed.

- Robot Manufacturer: Select the relevant robot manufacturer (UR Polyscope 5 URcap, UR Polyscope X Script, Kuka, ABB, Kassow Robotics, Fanuc or Generic).
- Robot Port: Depending on the robot manufacturer the default port is shown. Edit the port, if needed. Make sure to use a unique port.
- Current Calibration File: Shows the name of the currently loaded calibration file.
- Load Calibration File: Allows to load another calibration file. The calibration file is only valid for one specific device and valid only if the relation between camera, lens and robot is unchanged (e.g. it gets invalid if the camera position is changed or if the lens is changed, e.g. via another focus position at B60 auto-focus devices).

NOTE!



- Upload or download of calibration files is possible via File Management (see section „7.5 File Management“).
- Do not change the name of the calibration file.
- Loading another calibration file from the device website requires to disconnect and re-connect again from robot side to the robot server in order to get the changes also on robot side (e.g. in URCap).
- For more details about robot vision, see operating instruction of software wenglor uniVision 3 [DNNF023](#).

The following status is shown for the robot server:

- Robot Connection: Shows if the robot is connected to the robot server or not.
- Processing Instance Connection: Shows if the robot server is connected to the processing instance via the LIMA Read/Write Limited port or not.
- Device Robot: Shows if the robot server is connected to Device Robot Vision or not.
- Error: Shows if there is any error (e.g. if calibration file does not fit to the device).

Click on “Edit job” in the section “Current job” in order to open the uniVision software for editing the uniVision job.

NOTE!

- Make sure that the suitable version of the software wenglor uniVision 3 is installed on the PC.
- For details about the suitable version of the software wenglor uniVision 3, check the uniVision version of the device at the tab “Dashboard” (see section „7.2 Dashboard“).
- Click on the link to open the product detail page of the software wenglor uniVision 3 ([DNNF023](#)) in order to download the suitable software version at “Downloads” -> “Soft and Firmware” (only available with internet access).
- The uniVision software is described in detail in the operating instruction of the software wenglor uniVision 3 [DNNF023](#).



A screenshot of the uniVision software interface. The top navigation bar includes 'Dashboard', 'Interfaces', and 'Jobs'. The main content area shows details for 'processing-instance-1', which is 'Active' and 'Running'. It features three sections: 'Current Job' (1.u3p) with an edit icon highlighted by a blue box; a warning message stating 'uniVision 3 is required for editing the job. uniVision 3 download: https://www.wenglor.com/product/DNNF023'; and 'Visualization' (1.u3p) with another edit icon. At the bottom, there is a 'Startup Policy' section with radio buttons for 'Fix start job' and 'Last loaded job'. A blue help icon (?) is located in the bottom right corner of the interface.

Click on visualization opens the webbased job visualization in a separate tab of the browser.



NOTE!

The webbased visualization is described in the operating instruction of the software wenglor uniVision 3 [DNNF023](https://www.wenglor.com/product/DNNF023).

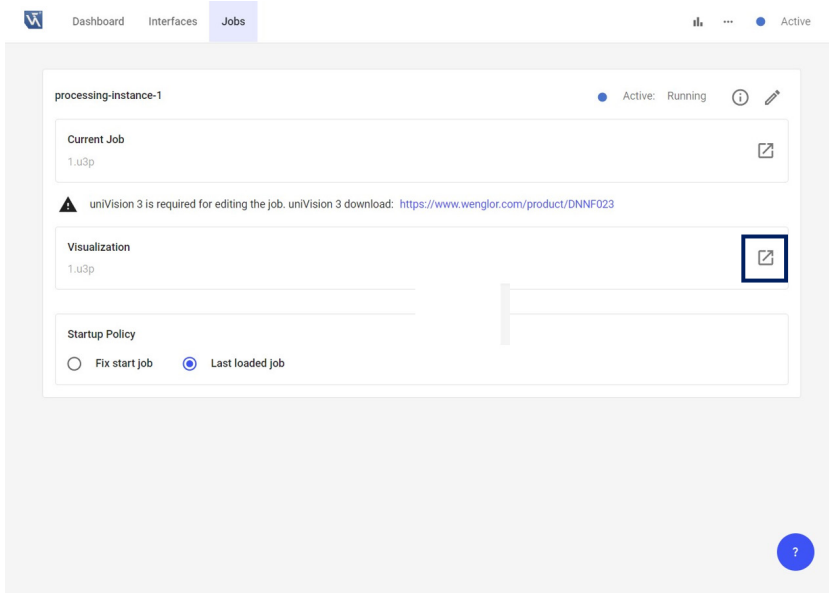

The screenshot shows a web-based interface for managing jobs. At the top, there is a navigation bar with 'Dashboard', 'Interfaces', and 'Jobs' (the active tab). On the right, there are icons for a bar chart, a list, and a status indicator 'Active'. The main content area displays details for 'processing-instance-1', which is currently 'Active: Running'. It includes sections for 'Current Job' (1.u3p), a warning message about uniVision 3 requirements, a 'Visualization' section (1.u3p) with a highlighted icon, and a 'Startup Policy' section with radio buttons for 'Fix start job' and 'Last loaded job'.

7.5 File Management

Click in the icon menu bar on the “File Management” icon in order to access files on the Machine Vision Device.

The following folders are available:

- Calibration: Contains calibration files for robot vision (see section „7.4 Jobs“).
- Input: Contains data (images) for the simulation mode. For details, see operating instruction of software wenglor uniVision 3 ([DNNF023](#)).
- Output: Contains data (e.g. images or text files) stored via Device FTP. For details, see operating instructions of [DNNF023](#).
- Projects: Contains uniVision job files.
- Teach-plus: Contains one single teachplus file for storing the uniVision job file temporarily on the device before downloading it to the projects folder of the host PC. For details, see operating instructions of [DNNF023](#).



Select one of the folders (e.g. projects) to access the files.



Click on the button “Upload” in order to upload files to the folder.

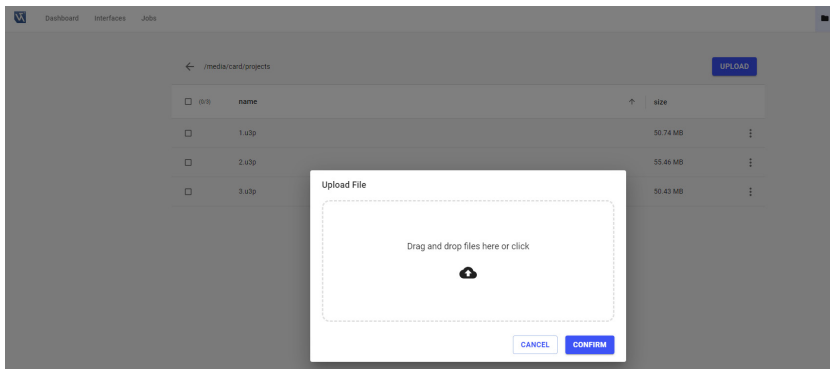

Click on the button “New Folder” to create a new folder.
Click on the extended menu to rename, duplicate, copy to, move to, download or delete files.



NOTE!



- It is possible to select several files in order to duplicate, copy to, move to, download or delete them.
- Do not edit the name of calibration files.

7.6 Diagnosis

Click in the icon menu bar on the “Diagnosis” icon in order to get further diagnosis info.

7.6.1 CPU

The side navigation “CPU” shows the CPU load of the Machine Vision Device for a maximum of the last 60 seconds.

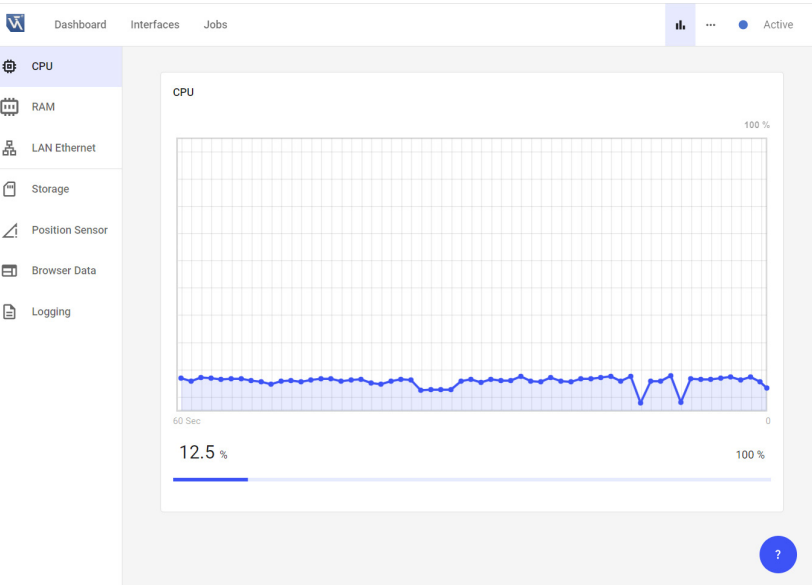

7.6.2 RAM

The side navigation “RAM” shows the RAM usage of the Machine Vision Device for a maximum of the last 60 seconds.

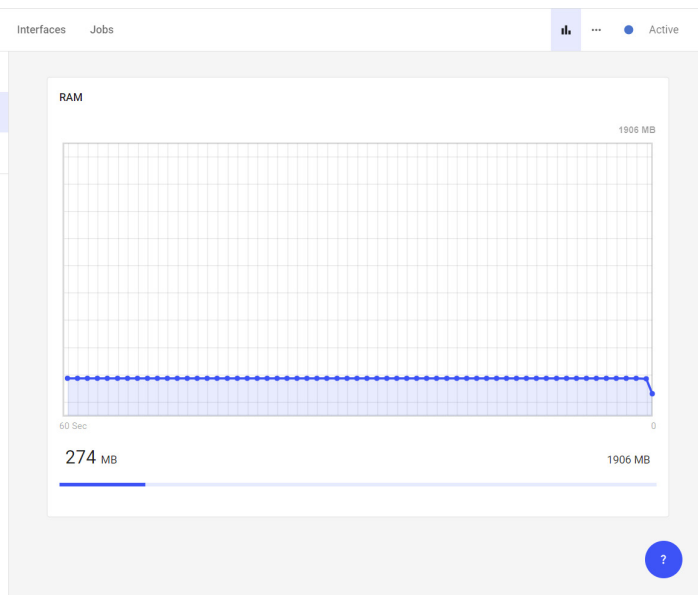

7.6.3 LAN Ethernet

The side navigation “LAN Ethernet” shows the network load at the LAN connector of the Machine Vision Device for a maximum of the last 60 seconds.

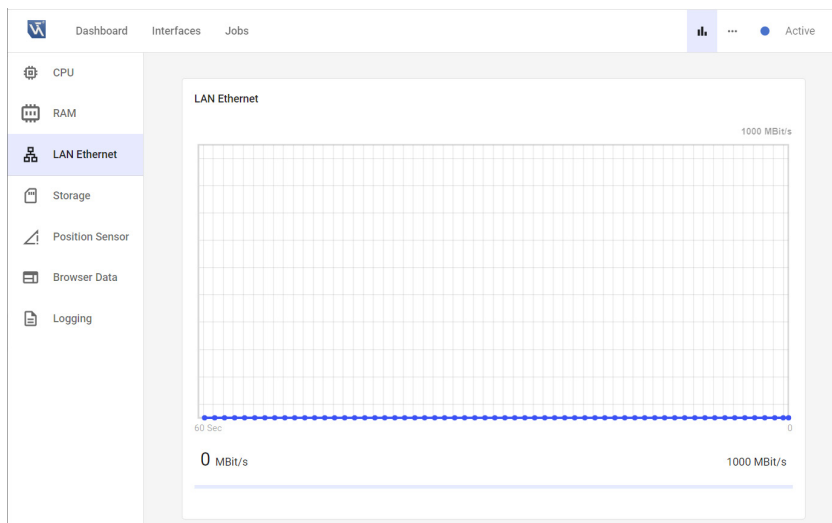

7.6.4 Storage

The side navigation “Storage” shows the currently occupied and the complete available user storage of the Machine Vision Device.

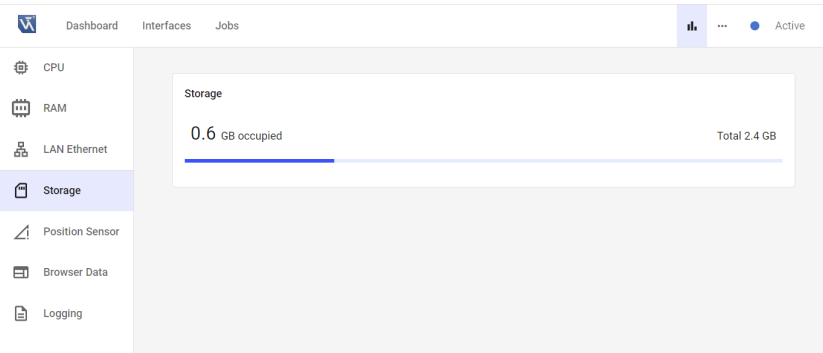

7.6.5 Position Sensor

The side navigation “Position Sensor” shows the angles of x and y of the internal position sensor that is part of the Machine Vision Device.



NOTE!

For details, see section „7.7.2 Position Sensor“.

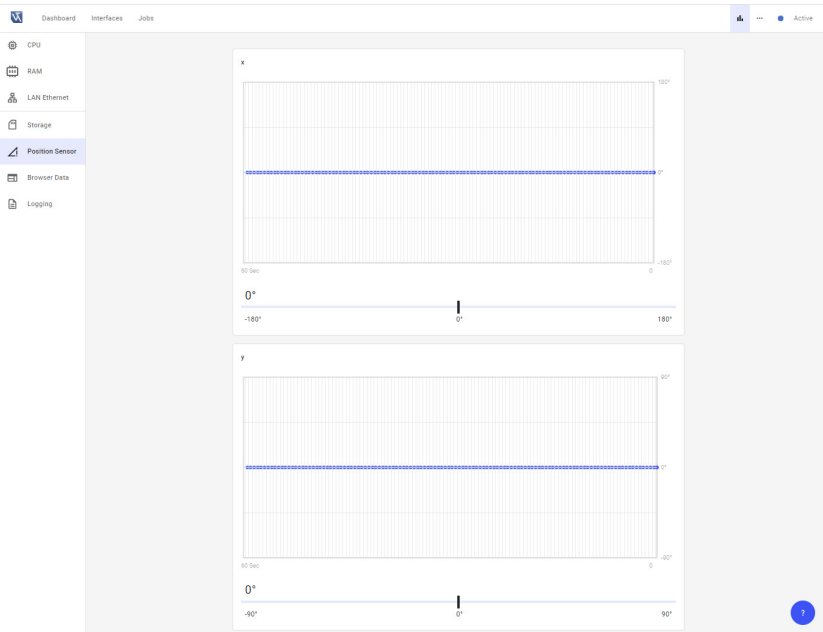

7.6.6 Temperature

The side navigation “Temperature” shows the temperature values of all temperature sensors within the Machine Vision Device for a maximum of the last 60 seconds.

The following temperature sensors are available:

- CPU Temperature
- DDR Temperature
- Internal Housing Temperature
- Illumination Module Temperature (only available at Smart Cameras with auto-focus if illumination module is attached)

7.6.7 Browser Data

The side navigation “Browser Data” shows the version of the currently used browser.

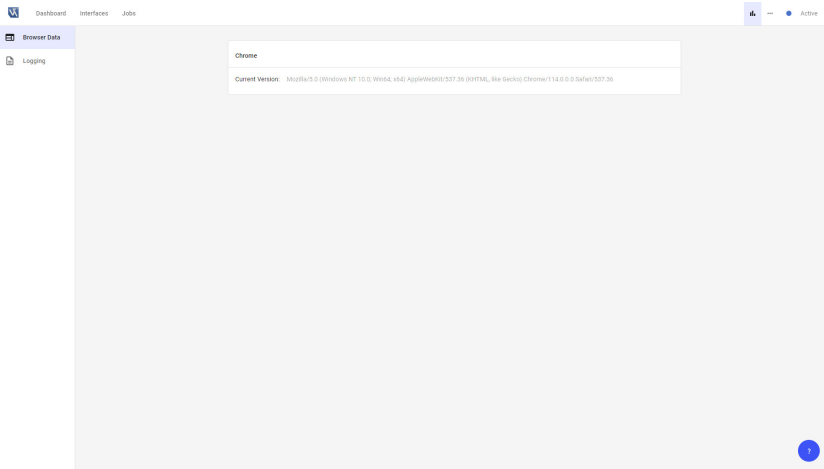

7.6.8 Logging

The side navigation “Logging” allows to download logging info for all services of the device in one zip file for the wenglor support and development team. Enabling “Logging” requires a reboot of the device (by default “Logging” is disabled).

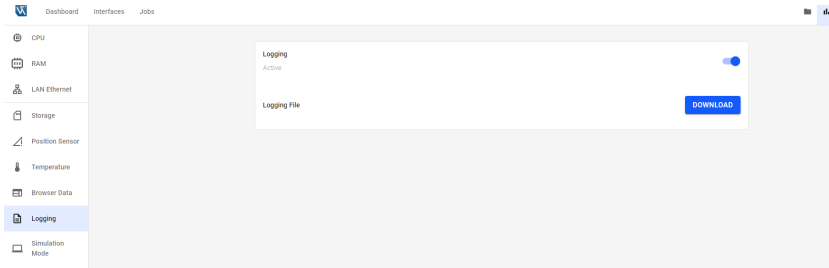

7.6.9 Simulation Mode

The side navigation “Simulation Mode” allows to activate the simulation mode on the Machine Vision Device. It is possible to evaluate reference data (e.g. images) of the input folder (see File Management on device website) in order to check the performance (process times) for each module on the real device. 2D images in bmp format with 8 bit depth and with maximum size of 24 MP are supported.



NOTE!

Activating the simulation mode stops all active processing instances on the Machine Vision Device. Make sure to save the jobs of active processing instances before activating the Simulation Mode.

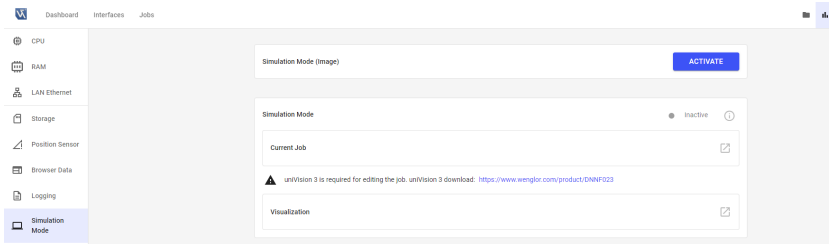

Open the current job in order to create a new job in simulation mode via the software wenglor uniVision 3 or open the visualization in a new browser tab in order to create a job specific visualization.



NOTE!

In Simulation Mode only certain interfaces are supported. For details, see operating instructions of software wenglor uniVision 3 ([DNNF023](#)).

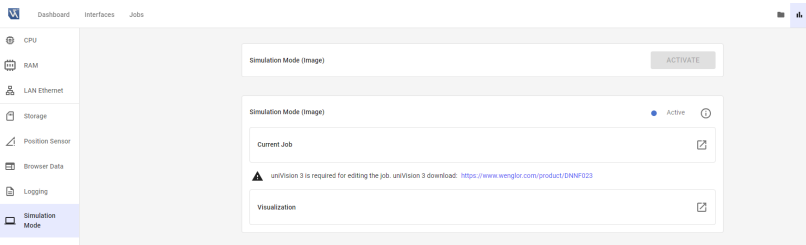

Reboot the device in order to exit the simulation mode and to start again in normal operating mode.



NOTE!

For details about the simulation mode on the Machine Vision Device, see the operating instructions of [DNNF023](#).

7.7 Settings

Click in the icon menu bar on the “Settings” icon for further device settings.

7.7.1 Button

The side navigation “Button” allows to activate or deactivate the functionality for the button on the device so that it is protected from unwanted changes, if needed. It is possible to activate or deactivate the complete button functionality or only single options (trigger, localize, network reset). By default, the button functionality is active. For details about the button functionality, see section „[3.7.2 Button](#)“.

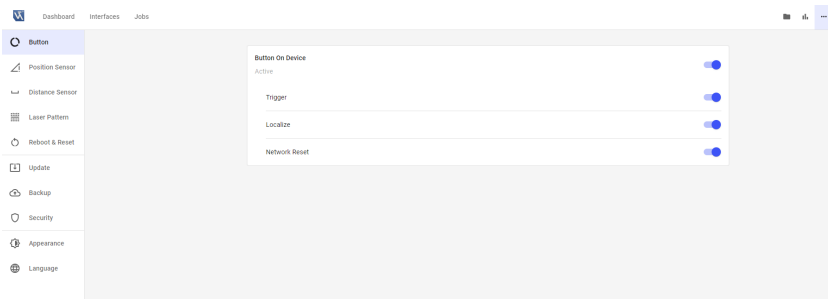

7.7.2 Position Sensor

The side navigation “Position Sensor” shows the current position (x, y) and acceleration (x, y, z) values of the device.

The following angle values are possible for the position in the x and y axis:

- X axis: Angle from -180 to 180 °.
- Y axis: Angle from 0 to 90 to 0 to -90 to 0 °. If y is bigger than 70 ° or smaller than -70 ° the gimbal lock effect leads to big changes on x values.

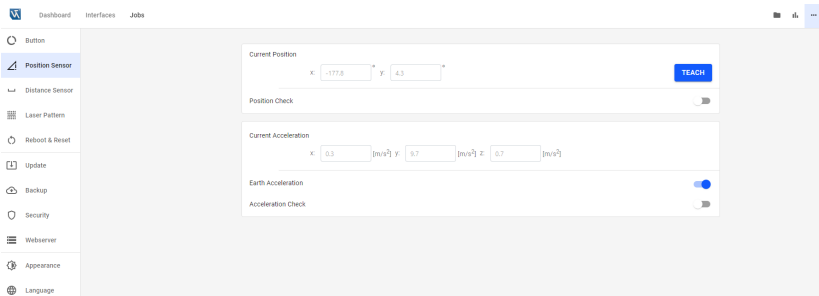

NOTE!

- Even when the device is switched off, position changes in x and y are detected and shown when the device is switched on again.
- Changes around z axis (gravitation axis) cannot be detected. Make sure when mounting the device, that unwanted position changes can be detected by the software via changes around x and y axis.
- The angles of x and y axis are long-term stable with tolerances of ± 2 °
- The acceleration due to gravity is recognized and distributed to the three axes depending on the orientation of the camera.

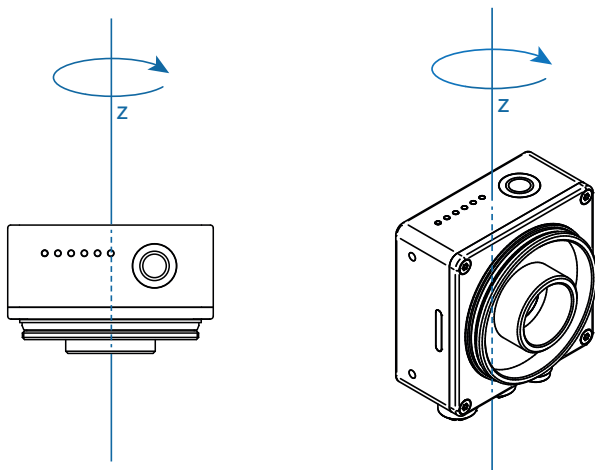

Click on Teach in order to set the current position as new reference. The current position of x and y will then display 0°.

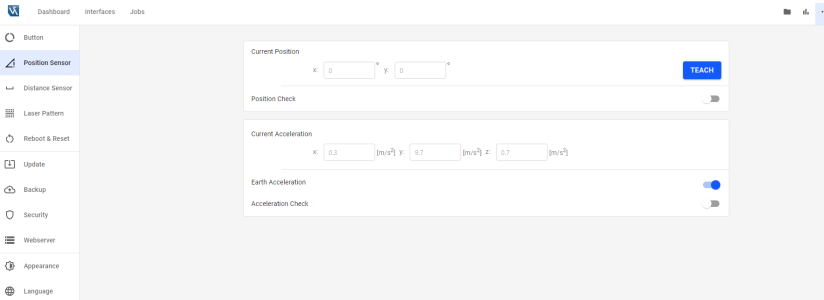

Activate the “Position Check” (default: deactivated), in order to detect unwanted position changes with the device status LED.

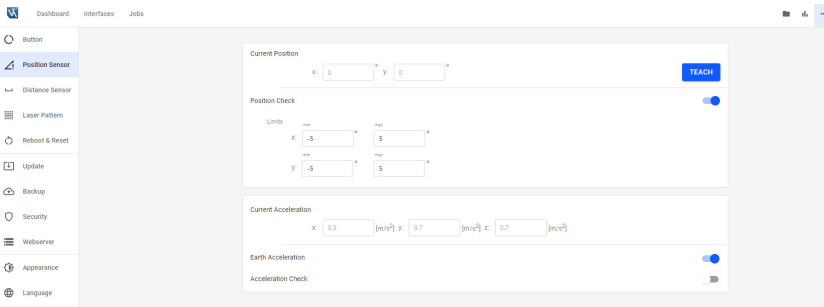

If the current position is out of the limits, the device status LEDs on the device and the device website show a warning info (see section „7.8 Device Status“).

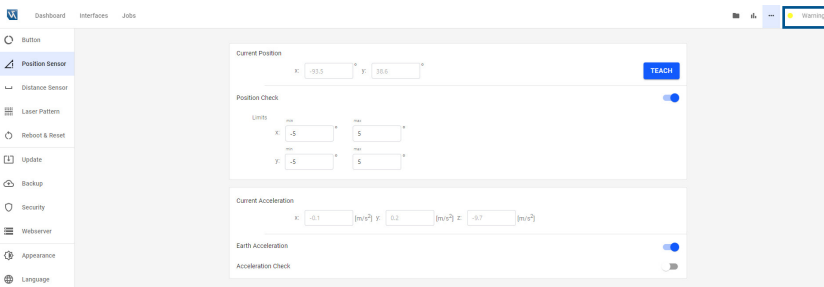

Deactivate the earth acceleration to only consider the real acceleration of the device (by default, the earth acceleration is activated).

Activate the “Acceleration Check” (default: deactivated), in order to detect unwanted shocks or vibrations with the device status LED.

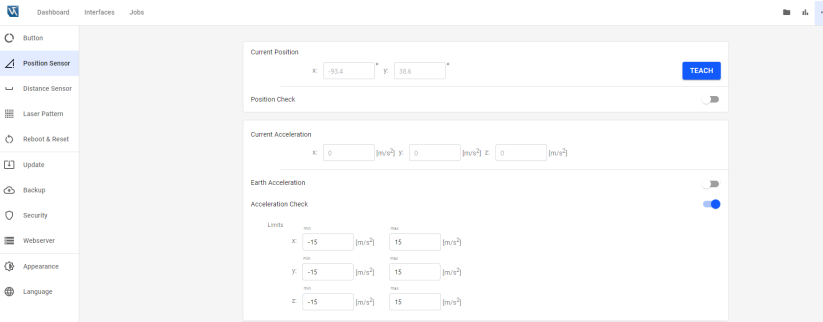

7.7.3 Distance Sensor

Activate the distance sensor (default: inactive), in order to detect distance values of the ToF sensor.



NOTE!

The side navigation “Distance Sensor” is only available at Smart Cameras with auto-focus and attached illumination module. The distance sensor is located on the illumination module.

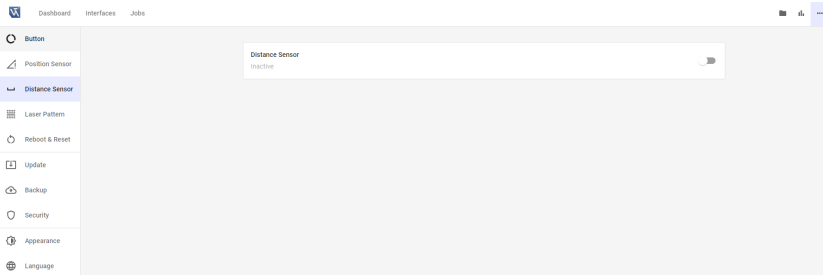

If activated, the side navigation “Distance Sensor” shows the parameter “Protective Tube” and the current distance values of the Time of Flight (ToF) sensor.
 By default, the parameter “Protective Tube” is deactivated. Keep it deactivated, if no protective tube is mounted on the illumination module.

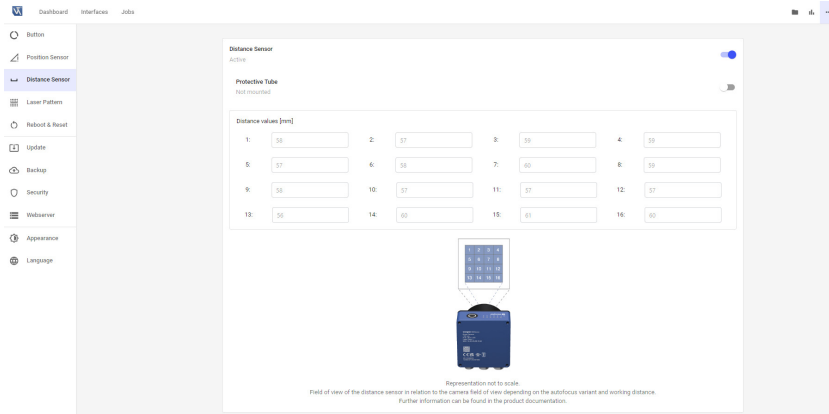

In case of a mounted protective tube on the illumination module, activate the parameter “Protective Tube”. Enabling it, allows to calibrate the Distance Sensor (required because of the glass of the protective tube). The calibration must only be done once if the setup does not change (protective tube and illumination module are unchanged). In case of exchanging the illumination module, re-calibrate if using the protective tube. While calibrating make sure that the Machine Vision Device looks on a plane target with a fix distance (bigger than 600 mm from the Distance Sensor) that covers all beams of the Distance Sensor. Furthermore make sure to have constant lightning conditions without reflections when calibrating. Check if the distance values are correct after the calibration.

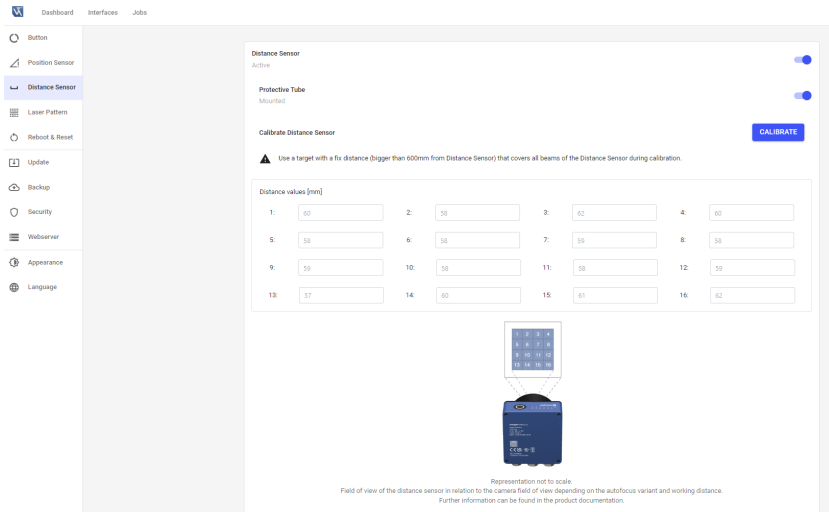

The following 16 distances values are available.



NOTE!



- If the distance values are out of the working range of the distance sensor (e.g. too close or too far away), the result “Not available” is shown on the device website.
- For details about the distance sensor, see section „[3.1.7 Multizone Distance Sensor](#)“.

7.7.4 Laser Pattern

The side navigation “Laser Pattern” allows to adjust the laser pattern.

- **Synch with Localize:** By default, the laser pattern is synchronized with localize. Activating localize, also activates the laser pattern and deactivating localize also deactivates the laser pattern. If needed, deactivate the synchronization.
- **Laser Pattern:** Activating or deactivating the laser pattern independent of localize is possible via the buttons “Activate” and “Deactivate”.
- **Laser Pattern Status:** Shows the current status of the laser pattern (active or inactive).



NOTE!

The side navigation “Laser Pattern” is only available at Smart Cameras with auto-focus.

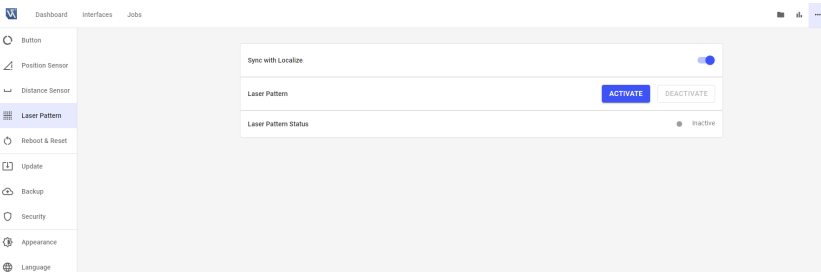

7.7.5 Reboot & Reset

The side navigation “Reboot & Reset” allows to perform a software reboot of the device. Furthermore it is possible to reset the settings of the device website to the defaults.

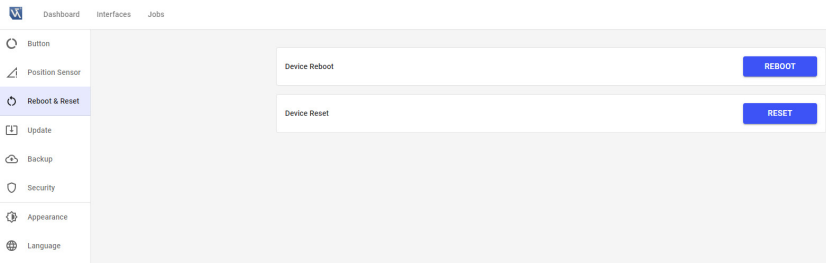

NOTE!



Device reset only resets the settings on the device website. It does not reset the camera settings (e.g. exposure time), the uniVision jobs or the calibration files. Furthermore, the LAN network settings and the configuration file for Industrial Ethernet are not reset. Resetting the LAN network settings and the RTE configuration file is possible separately.

7.7.6 Update

The side navigation “Update” shows the current firmware version and allows to update the firmware of the device.

“Current version” shows the current firmware version.

Clicking on the link opens a new tab in the browser to the product detail page on the wenglor website. The latest firmware version is available at “Downloads” → “Soft and Firmware” (only available with internet access).

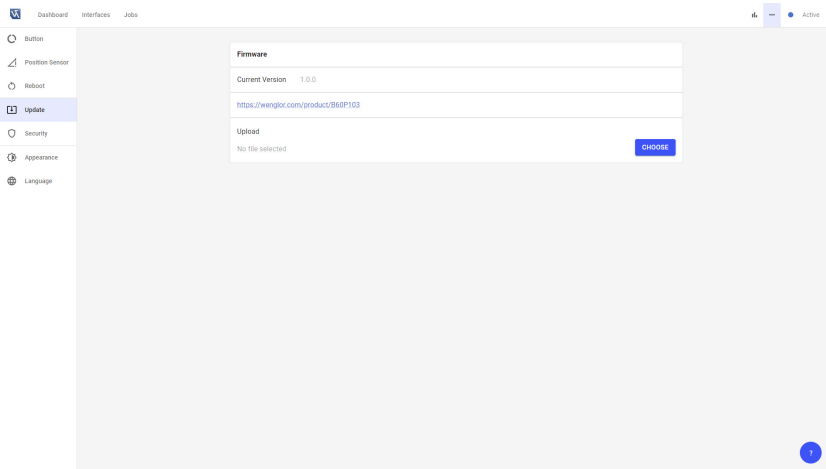

Click on “Choose” and select the *.swu firmware update file.

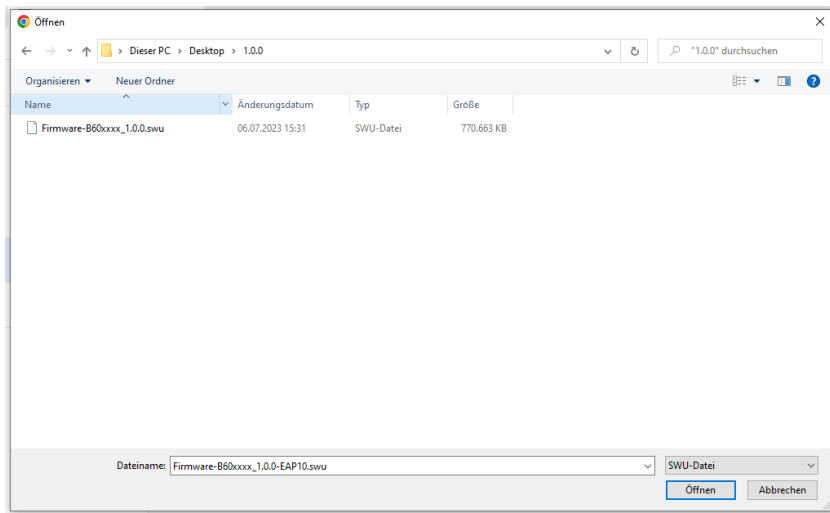

Click on OK to start the firmware update. During the firmware update, a software reboot is automatically done.

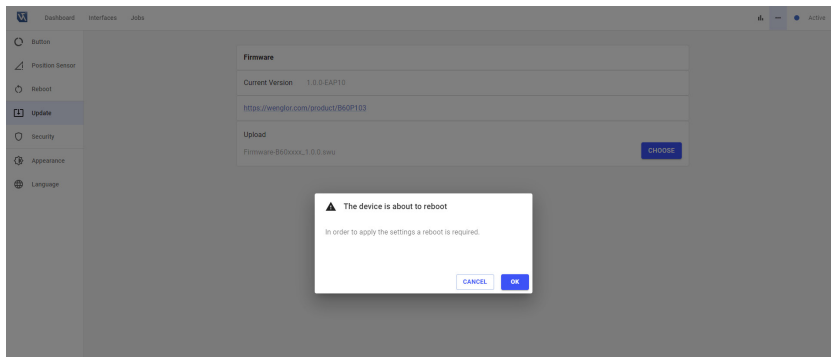

Firmware Compatibility

The firmware version number consists of three digits (e.g. Firmware B60 1.0.0).

- Major release: The first digit is changed (no compatibility).
- Feature release: The second digit is changed.
- Bugfix release: The third digit is changed.

The following applies with regard to the compatibility of the device website:

- At a bugfix release, the settings of the device website are unchanged.
- At a feature release upgrade (second digit increases), the settings of the device website remain.
- At a feature release downgrade (second digit decreases), it is possible that the settings of the device website are set back to default.

NOTE!



- A backup of the device settings for the device website is done when the device settings change at a firmware update or downgrade (contains maximum one backup file).
- Contact the wenglor support team (email to support@wenglor.com) in case of activating again the settings of the device website on a compatible firmware version.

7.7.7 Backup

The side navigation “Backup” allows to create and to restore a backup of the settings for the device website.

- Backup: Creates a backup file for the settings of the device website.
- Restore: Allows to restore a backup on the device. Restoring a backup file is only possible in case of the same device type (article number) and the same firmware version of the device. If loading the backup file on another device with the same article number, make sure that the same firmware version (and if needed the same configuration file for Industrial Ethernet) is installed on it before restoring the backup.

NOTE!



- The backup does not include the content of the file location /media/card (e.g. uniVision jobs or calibration files for robot vision). Store uniVision jobs and calibration files separately, if needed.
- The backup does not include the configuration file for Industrial Ethernet. Make sure to install the suitable configuration file for Industrial Ethernet individually.
- The backup does not include the network configuration of the LAN Ethernet connector. Make sure to set the LAN network configuration accordingly.

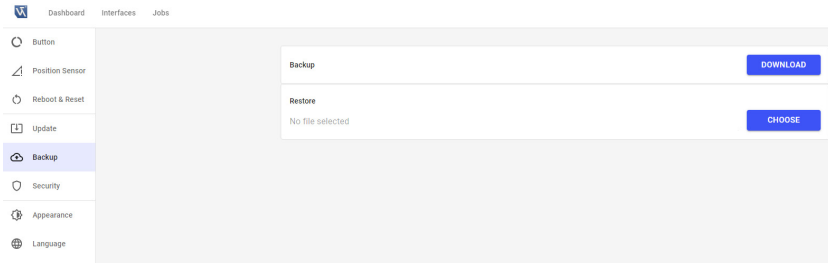

7.7.8 Security

The side navigation “Security” allows to activate authentication in order to protect the device from unwanted changes. After activating authentication, the button “Login” appears at the icon menu bar. The following table shows the rights for each user group.

Functionality	Admin or admin (default)	Setter	Worker	Logged off
Software wenglor weHub: <ul style="list-style-type: none"> • Find devices • Open devices extended view • Access device website 	Yes	Yes	Yes	Yes
Software wenglor weHub: <ul style="list-style-type: none"> • Start/stop localizing • Edit name and network settings • Enable and disable “Auto connect weHub to device” 	Yes	No	No	No
Device website: See properties	Yes	Yes	Yes	Yes
Device website: Edit properties	Yes	No	No	No
Access and edit job configuration via software wenglor uniVision 3	Yes	Yes	No	No
Access and see webbased visualization	Yes	Yes	Yes	Yes
Interact in Run Mode on webbased visualization	Yes	Yes	Yes	No
Edit webbased visualization	Yes	Yes	No	No



NOTE!

Remember usernames and passwords! In case of lost passwords, contact support@wenglor.com

By default, authentication is deactivated.

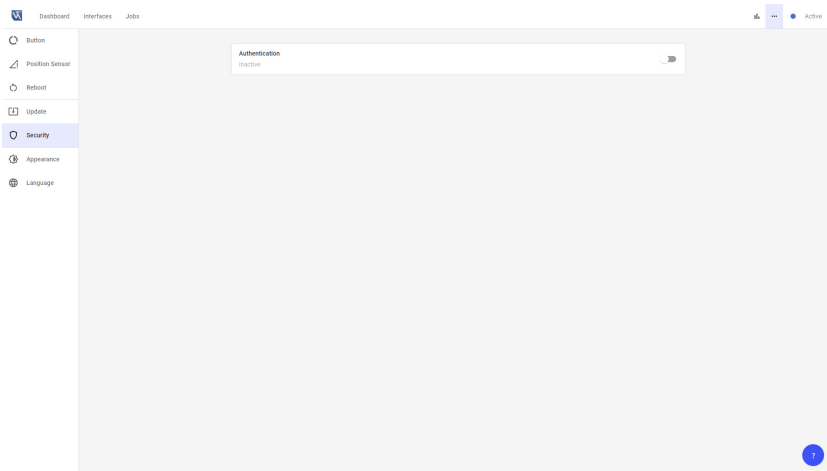

Enable authentication and click on OK.

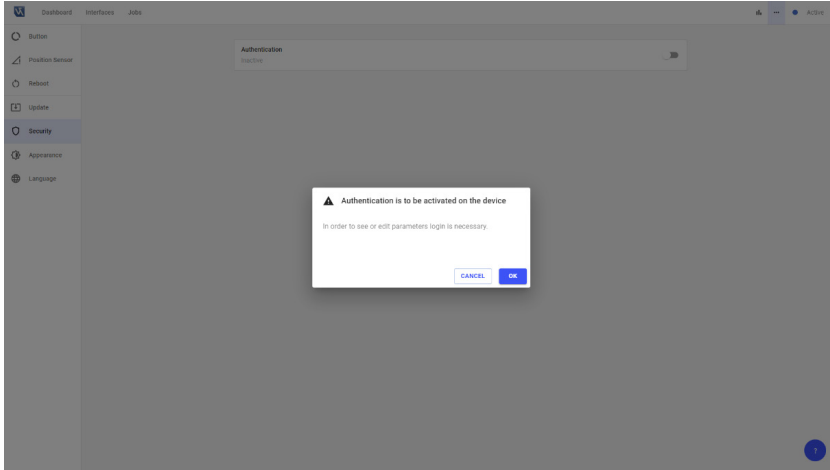

If authentication is active, the button “Login” appears in the icon menu bar.

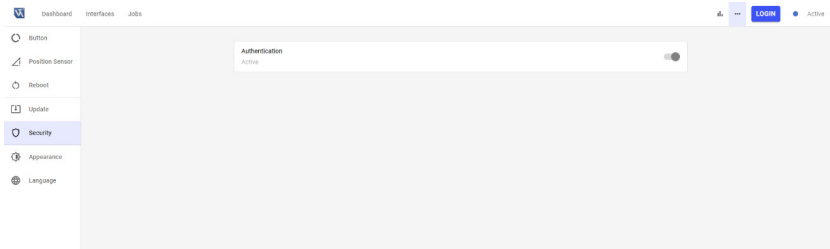

Enter username and login. Use admin (default) to login for the first time.

- Username: admin
- Password: admin

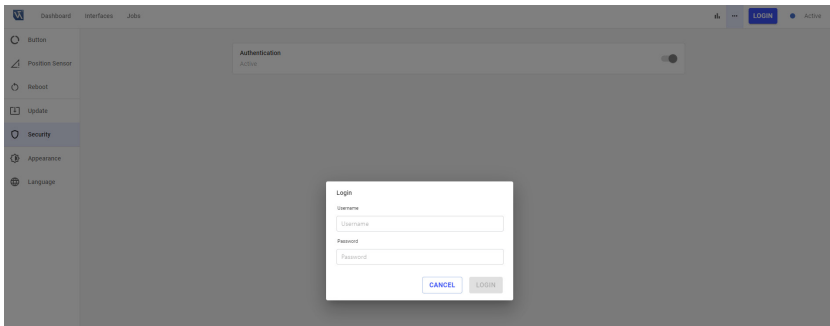

Edit username or password of admin (default) via clicking on “Manage account”.

NOTE!



- Change the password of admin (default) to prevent unwanted access on the device.
- The admin (default) account cannot be deleted and it is not possible to change the user group.

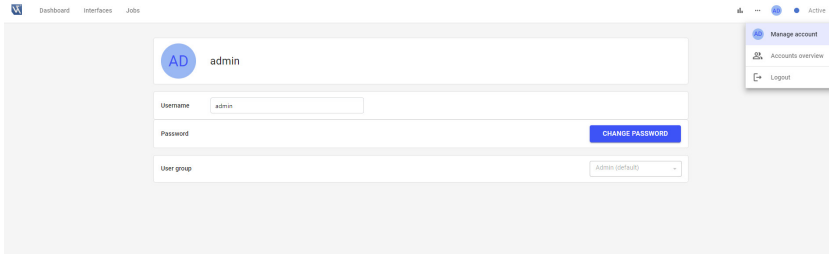

Admins and admin (default) can create new accounts, edit and delete other accounts. Setter and Worker can only change the own username or password.

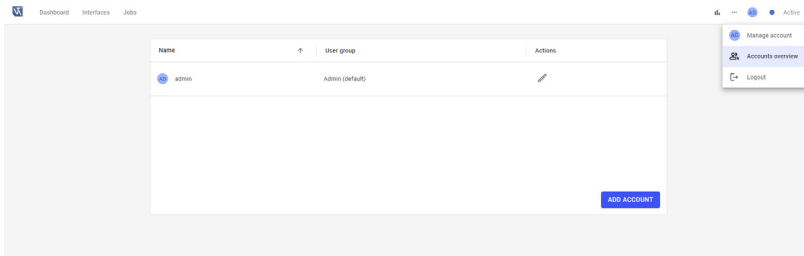

Enter username, password and user group when creating new accounts.

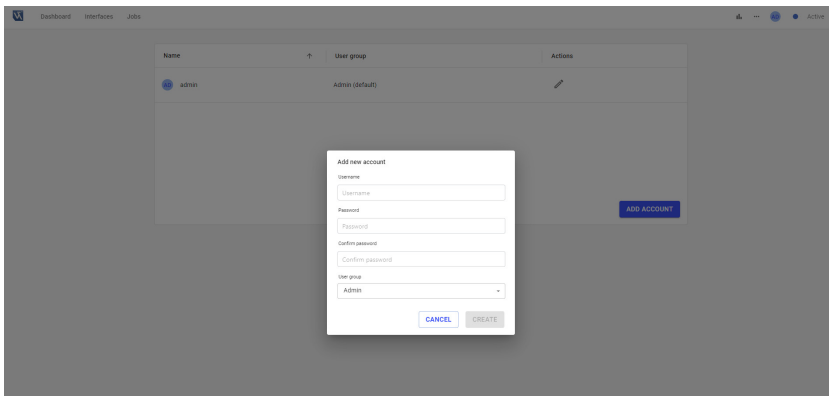

7.7.9 Webservice

The side navigation “Webservice” allows to configure the webservice.

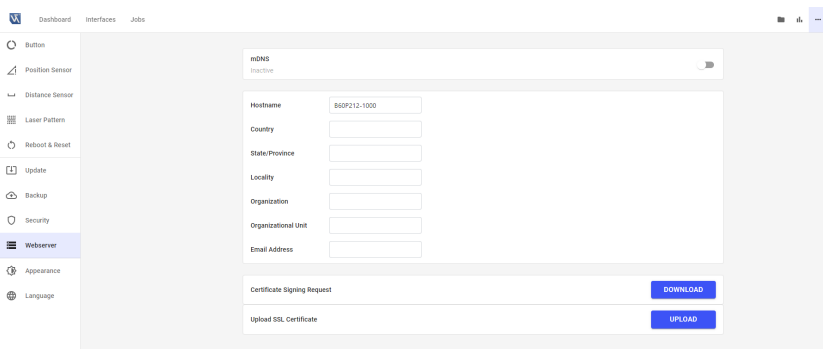

Activate mDNS in order to access the device website via the hostname. By default, the hostname is “article number”-“serial number” (e.g. b60p212-1000).

Refresh the browser in order to see the automatic redirection of the IP address to the hostname in the address line of the browser (if “Automatic Redirection” is active).

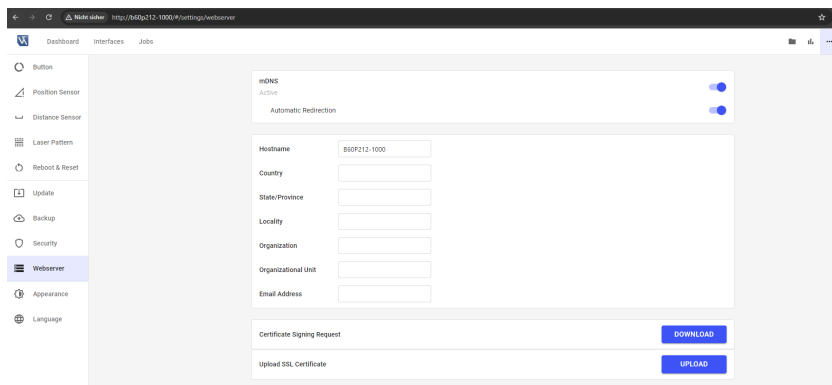

Enter country, state/province, locality, organization, organizational unit and email address before generating the certificate signing request.



NOTE!

For creating the SSL certificate of the Machine Vision Device and in order to add it as trusted device at your PC, please get in touch with your IT department.

After successfully uploading the SSL certificate, the parameter HTTPS appears. Activate it in order to access the device via https. Refresh the browser in order to see the automatic redirection of http to https (if “Automatic Redirection” is active).

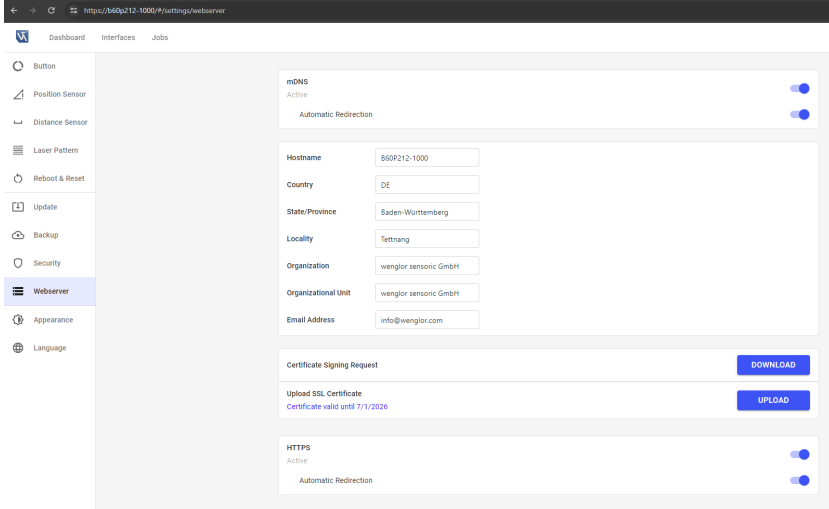

NOTE!

Delete the browser data after deactivating mDNS or HTTPS in order to access again the device website.

7.7.10 Appearance

The side navigation “Appearance”, allows to activate or deactivate dark theme. By default, dark theme is deactivated.

Bright Theme

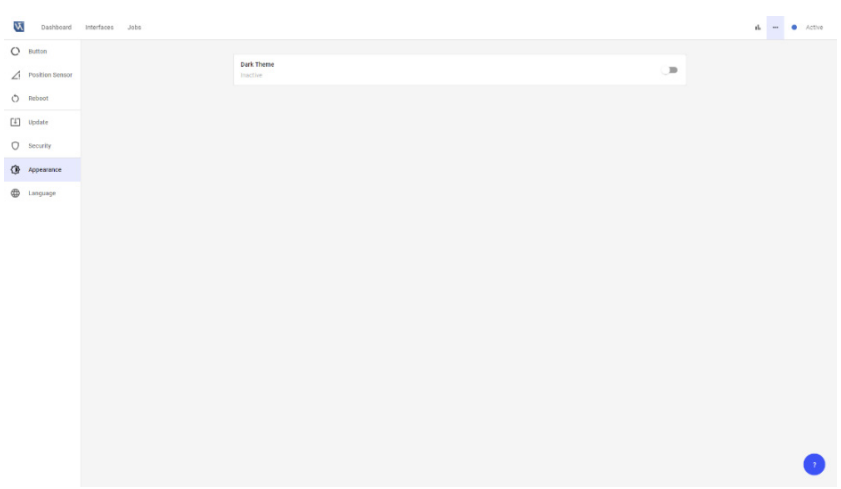

Dark Theme

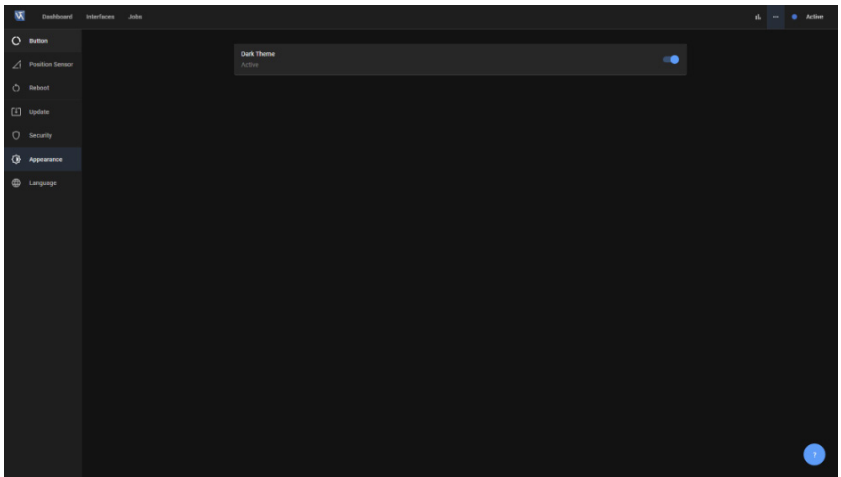

7.7.11 Language

The side navigation “Language” defines the user language of the device website (DE, EN, FR, IT, ES, PT, NL, HU, TR, ZH, RU).

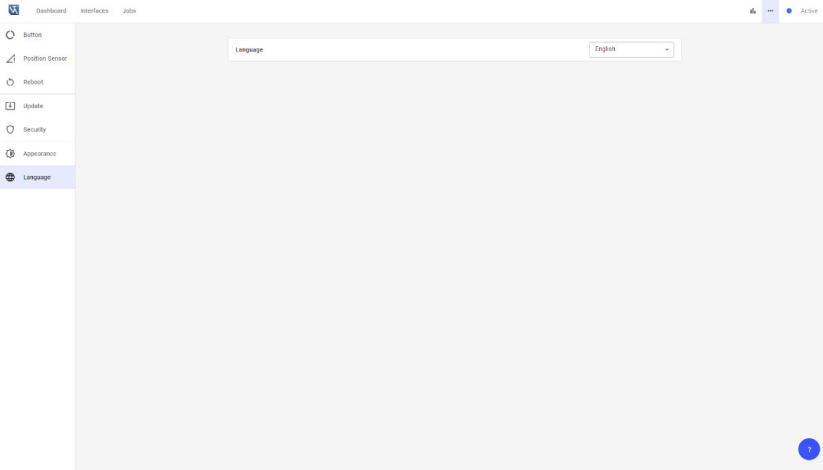

7.8 Device Status

Open the device status in the icon menu bar for further status info. Furthermore, it is possible to download the history of the maximum 50 last device status warnings and errors (automatically reset after rebooting the device).

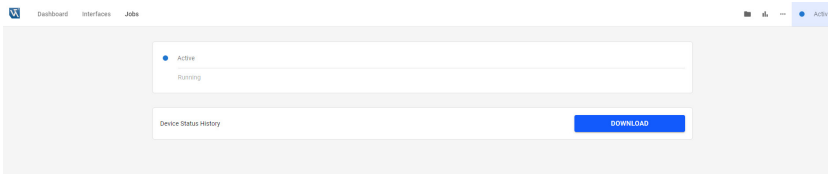

The device status signals the following states:

- Blue On: Active (Running)
- Blue Blinking: Localizing (activate/deactivate localizing via button on device, see section „3.7.2 Button“, or via software wenglor weHub)
- Yellow: Warning (e.g. in case of unwanted position change, too high acceleration, too high temperature, CPU throttling, high CPU load, high RAM, high storage usage or high LAN Ethernet. Typically warning is sent, if CPU load, RAM, storage usage or LAN Ethernet is bigger than 90% for more than 3 seconds.)
- Red: Error (e.g. in case of crashed software, defect or blocked auto-focus module, crashed RTU or uncalibrated analog output)

NOTE!



- The device status is also visualized via the two LED strips on the device (see section „3.7.3 Device Status LEDs“)
- Details about activating or deactivating localizing, see operating instruction of software wenglor weHub and section „3.7.2 Button“).
- All warning and error messages are described in section „3.7.3 Device Status LEDs“.

If position check is activated, unwanted position changes are shown via the device status (see section „7.7.2 Position Sensor“).

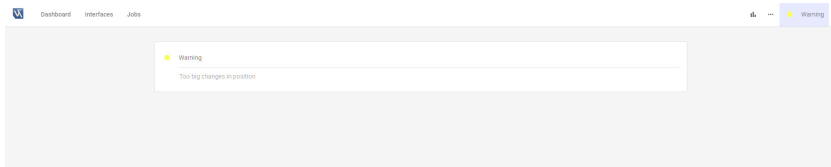

7.9 Help Button

Open the help button to access further information.

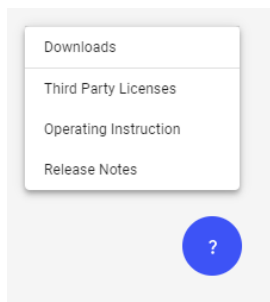

- Downloads: Opens a new tab in the browser with the product detail page of the device containing all available downloads on the wenglor website (only available with internet access).
- Third Party Licenses: Opens a new tab in the browser to access the third party licenses of the device (no internet access necessary).

NOTE!



Third party software licenses are also available on the wenglor website:
<https://www.wenglor.com/License/s/License>.

- Operating Instruction: Opens the operating instruction of the B60 Smart Camera in a new tab of the browser.
- Release Notes: Opens the release notes of the B60 firmware in a new tab of the browser containing the changes between different firmware versions.

8. Software wenglor uniVision 3

The B60 is parameterized with the uniVision software (version 3.0.0 or higher). For details on the parameterization of the camera settings and the uniVision modules, please refer to the operating instructions for the wenglor uniVision 3 software. For more information, see: <https://www.wenglor.com/p/DNNF023>

9. Maintenance Instructions

NOTE!



- This Smart Camera does not require any cyclical recalibration.
- Regular inspection of the plug connections is recommended.
- Cleaning of lens covers at regular intervals is recommended in order to assure uniform good quality of the acquired image and evaluation. A commercially available cloth for cleaning eyeglasses can be used for this purpose.
- Do not clean the Smart Camera with solvents or cleansers which could damage the product.

10. Proper Disposal

wenglor sensoric GmbH does not accept the return of unusable or irreparable products. Respectively valid national waste disposal regulations apply to product disposal.

11. Change Index of Operating Instruction

Version	Date	Description/Changes	Compatibility
1.0.0	21.08.2023	Initial version of the operating instructions of B60 Smart Cameras with C-Mount	Software: wenglor uniVision 3.0.0 Firmware B60: 1.0.0
1.0.1	26.09.2023	Updated info for firmware B60 1.0.1: <ul style="list-style-type: none"> Recommended maximum trigger frequency (see „3. Technical Data“). Position sensor update (see section „7.7.2 Position Sensor“) 	Software: wenglor uniVision 3.0.1 Firmware B60: 1.0.1
1.0.2	13.12.2023	<ul style="list-style-type: none"> Adding BIS Symbol Small bugfix and adaptations 	Software: wenglor uniVision 3.0.1 Firmware B60: 1.0.1
1.1.0	14.12.2023	<ul style="list-style-type: none"> Updated description for version 1.1.0 of B60 firmware 	Software: wenglor uniVision 3.1.0 Firmware B60: 1.1.0
1.2.0	06.03.2024	<ul style="list-style-type: none"> Added B60 auto-focus Smart Camera Additional data on interfaces General additions and improvements 	Software: wenglor uniVision 3.1.0 Firmware B60: 1.1.0
1.2.1	11.04.2024	Updated description for version 1.1.2 of B60 firmware	Software: wenglor uniVision 3.1.2 Firmware B60: 1.1.2
1.3.0	22.05.2024	Updated description for version 1.2.0 of B60 firmware	Software: wenglor uniVision 3.2.0 Firmware B60: 1.2.0
1.4.0	02.09.2024	Updated description for version 1.3.0 of B60 firmware	Software: wenglor uniVision 3.3.0 Firmware B60: 1.3.0
1.5.0	27.02.2025	Updated description for version 1.4.0 of B60 firmware	Software: wenglor uniVision 3.4.0 Firmware B60: 1.4.0
1.6.0	07.07.2025	Updated description for version 1.5.0 of B60 firmware	Software: wenglor uniVision 3.5.0 Firmware B60: 1.5.0
1.7.0	20.08.2025	<ul style="list-style-type: none"> Updated description for version 1.6.0 of B60 firmware New charts for homogeneity and intensity 	Software: wenglor uniVision 3.6.0 Firmware B60: 1.6.0
1.7.1	19.11.2025	Adaptions in section „5.4 Connection to External Illumination and Trigger Sensor“	Software: wenglor uniVision 3.6.0 Firmware B60: 1.6.0

Version	Date	Description/Changes	Compatibility
1.8.0	20.05.2026	<ul style="list-style-type: none"> Updated description for version 1.7.0 of B60 firmware (including a new NTP client and enhanced warning/diagnostic messages) Updated technical data for hardware revision F or G (for Smart Camera B60 C mount) and D (for Smart Camera B60 Auto-Focus) Added hardware version table 	Software: wenglor uniVision 3.7.0 Firmware B60: 1.7.0

12. Appendix

12.1 Declarations of Conformity

Declarations of conformity can be found on our website at www.wenglor.com in the product's separate download area.

wenglor sensoric GmbH
 wenglor Straße 3
 88069 Tettnang
 GERMANY
 Phone: +49 7542 5399-0
info@wenglor.com

For further wenglor contacts please see www.wenglor.com

12.2 Third Party Licenses

Third party licenses used on the B60 Smart Camera are available via the device website (see section „7.9 Help Button“) or on the wenglor website (requires internet access) at:
<https://www.wenglor.com/License/s/License>