

# Laser Distance Sensor Triangulation

## P3PC202

Part Number

inspect  
award 2024



- 2 mutually independent switching outputs
- Integrated jump detection
- Intuitive operating concept
- Rugged aluminium housing
- Switching point independent of material, color and brightness

These laser distance sensors work with a fine red light beam and a high-resolution CMOS line. They determine the distance between the sensor and the object by means of the triangulation principle. Thanks to the integrated TripleA technology, the sensors offer high precision, temperature stability and material independence. This means they deliver accurate results even with objects of different materials, colors and shapes, as well as in fluctuating light and temperature conditions. The intuitive operating concept simplifies initial start-up and makes the sensors versatile all-rounders.

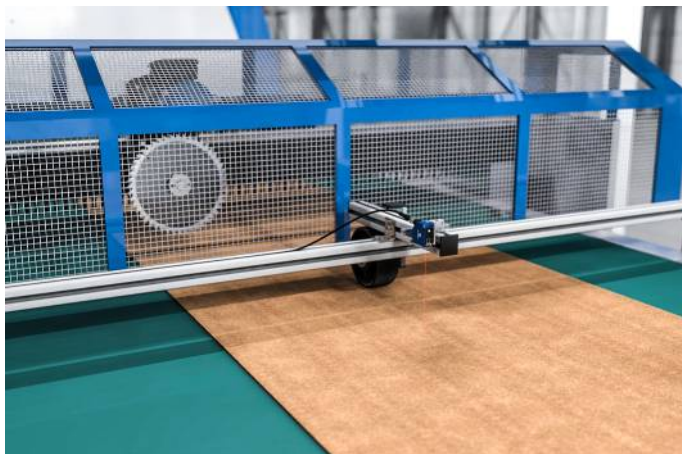

### Technical Data

Optical Data	
Working Range	50...350 mm
Setting Range	50...350 mm
Reproducibility maximum	100 $\mu$ m
Reproducibility: 1 Sigma	10 $\mu$ m
Linearity Deviation	300 $\mu$ m
Switching Hysteresis	< 0,5 %
Light Source	Laser (red)
Wavelength	655 nm
Service Life (T = +25 °C)	100000 h
Laser Class (EN 60825-1)	1
Max. Ambient Light	10000 Lux
Light Spot Diameter	see Table 1
Electrical Data	
Supply Voltage	18...30 V DC
Current Consumption (U <sub>b</sub> = 24 V)	< 50 mA
Switching Frequency	650 Hz
Response Time	< 0,5 ms
Temperature Drift	< 20 $\mu$ m/K
Temperature Range	-30...60 °C
Number of Switching Outputs	2
Switching Output Voltage Drop	< 1,5 V
Switching Output/Switching Current	100 mA
Short Circuit Protection	yes
Reverse Polarity Protection	yes
Overload Protection	yes
Interface	IO-Link V1.1
IO-Link Version	1.1
IO-Link transmission speed	COM3
Protection Class	III
FDA Accession Number	2310674-000
Mechanical Data	
Setting Method	Teach-In
Housing Material	Aluminum, anodised
Housing Material	Plastic, ABS
Degree of Protection	IP67
Connection	M12 x 1; 5-pin
Optic Cover	Plastic, PMMA
Safety-relevant Data	
MTTFd (EN ISO 13849-1)	720,35 a
NPN NO	●
IO-Link	●
Connection Diagram No.	243
Control Panel No.	X5
Suitable Connection Equipment No.	2   35
Suitable Mounting Technology No.	380

### Complementary Products

IO-Link Master	
Protective Screen	
Software	

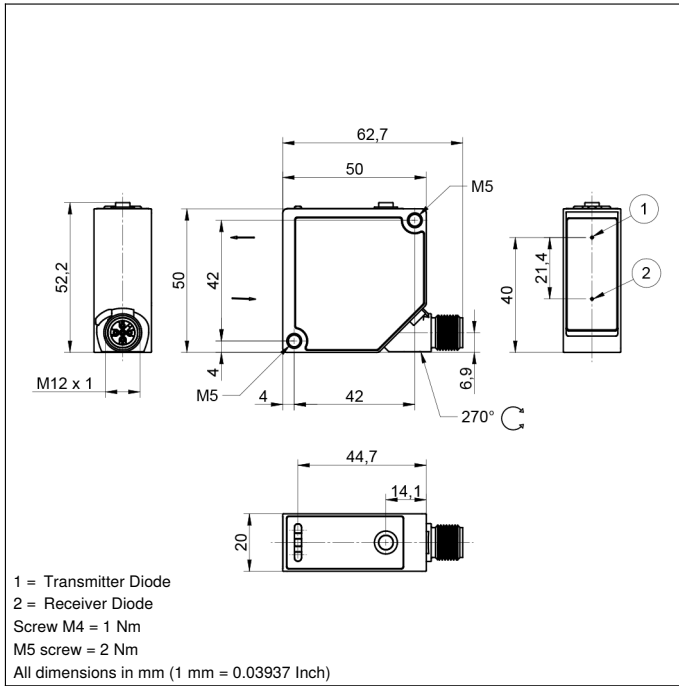

### Ctrl. Panel

X5

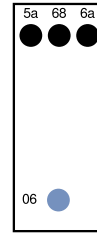

06 = Teach Button  
 5a = Switching Status Indicator, A1  
 68 = Power LED  
 6a = Switching Status Indicator, A2

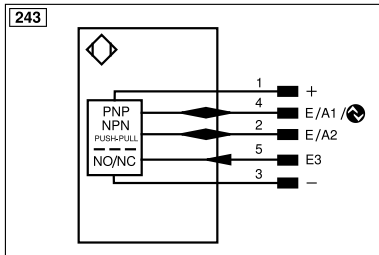

Legend			
+	Supply Voltage +	nc	Not connected
-	Supply Voltage 0 V	U	Test Input
~	Supply Voltage (AC Voltage)	Ü	Test Input inverted
A	Switching Output (NO)	W	Trigger Input
Ā	Switching Output (NC)	W-	Ground for the Trigger Input
V	Contamination/Error Output (NO)	O	Analog Output
ȳ	Contamination/Error Output (NC)	O-	Ground for the Analog Output
E	Input (analog or digital)	BZ	Block Discharge
T	Teach Input	Amv	Valve Output
Z	Time Delay (activation)	a	Valve Control Output +
S	Shielding	b	Valve Control Output 0 V
RxD	Interface Receive Path	SY	Synchronization
TxD	Interface Send Path	SY-	Ground for the Synchronization
RDY	Ready	E+	Receiver-Line
GND	Ground	S+	Emitter-Line
CL	Clock	±	Grounding
E/A	Output/Input programmable	SnR	Switching Distance Reduction
IO-Link	IO-Link	Rx+/-	Ethernet Receive Path
PoE	Power over Ethernet	Tx+/-	Ethernet Send Path
IN	Safety Input	Bus	Interfaces-Bus A(+)/B(-)
OSSD	Safety Output	La	Emitted Light disengageable
Signal	Signal Output	Mag	Magnet activation
BI_D+/-	Ethernet Gigabit bidirect. data line (A-D)	RES	Input confirmation
ENo RS422	Encoder 0-pulse 0/Ü (TTL)	EDM	Contactor Monitoring
PT	Platinum measuring resistor	ENARs422	Encoder A/Ā (TTL)
			Encoder B/B̄ (TTL)
			Encoder A
			Encoder B
			Digital output MIN
			Digital output MAX
			Digital output OK
			Synchronization In
			Synchronization OUT
			Brightness output
			Maintenance
			Reserved
			Wire Colors according to DIN IEC 60757
			BK Black
			BN Brown
			RD Red
			OG Orange
			YE Yellow
			GN Green
			BU Blue
			VT Violet
			GY Grey
			WH White
			PK Pink
			GNYE Green/Yellow

Table 1

Detection Range	50 mm	200 mm	350 mm
Light Spot Diameter	1,5 mm	1 mm	1 mm

