

1D/2D Codescanner C5PC



Technical Manual

Table of Contents

1. General Specifications	6
1.1. C5PC Field of View and Installation Distance	10
1.2. Lighting Mode Table	11
1.3. Field of View Charts	11
1.4. Readability Tables	14
1.5. Grounding and Power	22
1.6. Accessories and Cables	24
2. Electrical Specifications	34
2.1. C5KC	34
2.2. C5PC	35
3. Serial Commands	36
4. Communications	37
4.1. Introduction	37
4.2. Communications Serial Commands	38
4.3. Custom Ethernet Link	39
4.4. Host Port Connections	47
4.5. Preamble	54
4.6. Postamble	54
4.7. USB HID/Keyboard	55
4.8. Entering ASCII Characters as Hex Values	59
4.9. USB Mass Storage Driver	59
5. Calibration	60
5.1. Calibration Serial Commands	60
5.2. Calibration Overview	60
5.3. Calibration Options	60
5.4. Additional Notes about Calibration	66
6. Read Cycle	67
6.1. Read Cycle Serial Commands Read Cycle Serial Commands	67
6.2. Read Cycle Setup	67
6.3. Multisymbol	68
6.4. Trigger Mode and Filter Duration	69
6.5. External Trigger Polarity	73
6.6. Serial Trigger	73
6.7. Start Trigger Character (Non- Delimited)	74
6.8. Stop Trigger Character (Non- Delimited)	74
6.9. End of Read Cycle	75
6.10. Capture Mode	77
6.11. Capture Timing	81
6.12. Image Processing Timeout	82
6.13. Image Storage	83
6.14. Decodes Before Output	84
7. Symbologies	85
7.1. Symbologies Serial Commands	85
7.2. Data Matrix	86
7.3. Aztec	88
7.4. QR Code	88
7.5. Micro QR Code	89
7.6. Code 39	89

7.7. Code 128/EAN 128.....	92
7.8. BC412.....	95
7.9. Interleaved 2 of 5.....	96
7.10. Code 93.....	99
7.11. Codabar.....	100
7.12. UPC/EAN.....	103
7.13. Pharmacode.....	107
7.14. Postal Symbologies.....	109
7.15. GS1 DataBar.....	112
7.16. PDF417.....	114
7.17. MicroPDF417.....	115
7.18. Composite.....	116
7.19. DotCode.....	117
8. I/O Parameters.....	118
8.1. I/O Parameters Serial Commands.....	119
8.2. Symbol Data Output.....	121
8.3. No-Read Message.....	124
8.4. Read Duration Output.....	125
8.5. Output Indicators.....	126
8.6. LED Configuration.....	128
8.7. Serial Verification.....	129
8.8. Setup button.....	130
8.9. Setup Button Modes.....	132
8.10. Configurable Output 1.....	134
8.11. Trend Analysis Output 1.....	137
8.12. ISO/IEC 16022 Symbol Quality Output 1.....	139
8.13. ISO/IEC 15415 Symbol Quality Output 1.....	142
8.14. ISO/IEC 15416 Symbol Quality Output 1.....	148
8.15. ISO/IEC 29158 Symbol Quality Output 1.....	155
8.16. Diagnostics Output 1.....	160
8.17. Other Outputs.....	161
8.18. Power On/Reset Counts.....	164
8.19. Time Since Reset.....	164
8.20. Service Message.....	165
8.21. User-Assigned Name.....	165
8.22. Output Object Info.....	166
8.23. Database Identifier Output.....	167
8.24. Quality Output.....	168
8.25. Image Push to Host.....	168
8.26. Image Push to Host Detailed Setup.....	170
9. Symbol Quality.....	174
9.1. Symbol Quality Serial Commands.....	175
9.2. Overview of Symbol Quality.....	175
9.3. Symbol Quality Separator/Output Mode.....	176
9.4. ISO/IEC 16022 Symbol Quality Output.....	177
9.5. wenglor Symbol Quality Output.....	179
9.6. ISO/IEC 15415 Symbol Quality Output.....	182
9.7. ISO/IEC 15416 Symbol Quality Output.....	186
9.8. ISO/IEC 29158 Symbol Quality Output.....	191

10. Matchcode	194
10.1. Matchcode Serial Commands.....	195
10.2. Overview of Matchcode	195
10.3. Matchcode Type	196
10.4. Sequence Step Interval	200
10.5. Match Replace.....	200
10.6. Mismatch Replace	201
10.7. New Master Pin	202
11. Camera and IP Setup	203
11.1. Camera and IP Setup Serial Commands.....	204
11.2. Window of Interest	205
11.3. Pixel Binning	207
11.4. Camera Settings	207
11.5. White Balance Settings (QSXGA Color Only)	208
11.6. Color Filter	209
11.7. Focus Setup.....	210
11.8. Illumination Brightness.....	211
11.9. Morphological Pre-Processing	213
11.10. Morphological Operation and Operator Size	213
11.11. Damaged Symbol	215
11.12. Linear Security Level	215
11.13. Advanced Decoding Parameters	216
12. Configuration Database.....	217
12.1. Introduction	218
12.2. Configuration Database Serial Commands	218
12.3. Number of Active Indexes.....	219
12.4. Configuration Database Status.....	219
12.5. Database Mode	225
12.6. Save Current Settings to Configuration Database.....	228
12.7. Load Current Settings from Configuration Database	228
12.8. Request Selected Index Settings.....	228
12.9. Request All Configuration Database Settings.....	229
13. Utilities	230
13.1. Operational Commands.....	231
13.2. Read Rate.....	233
13.3. Counters	234
13.4. Device Control	235
13.5. Master Database	236
13.6. Firmware.....	238
13.7. Default/Reset/Save	239
13.8. Reader Status Requests.....	241
13.9. Other Operational Serial Commands.....	243
14. Output Format	246
14.1. Output Format Serial Commands	247
14.2. Output Format Status	247
14.3. Format Assign.....	248
14.4. Format Extract	249
14.5. Format Insert	250
14.6. Output Filter Configuration.....	251
14.7. Number of Filters	253

15. Communications Protocol	254
15.1. Communications Protocol Command Table	255
16. ASCII Table	256
16.1. ASCII Table	257
17. Glossary of Terms.....	258
17.1. Glossary of Terms	259
18. Q & A	265

Appendices

This section contains hardware specifications, accessory and cable information, and product part numbering logic for C5KC, and C5PC readers.

1. General Specifications

C5KC

C5KC		C5KC001 / C5KC002	C5KC003 / C5KC004
Symbologies *1	1D Symbologies	Code 39, Code 128, BC412, Interleaved 2 of 5, UPC/EAN, Codabar, Code 93, Pharmacode, PLANET, Postnet, Japanese Post, Australian Post, Royal Mail, Intelligent Mail, KIX	
	2D Symbologies	Data Matrix (ECC 0-200), QR Code, Micro QR Code, Aztec Code, DotCode	
	Stacked Symbologies	PDF417, MicroPDF417, GS1 Databar (Composite and Stacked)	
Reading Performance *2	Number of Reading Digits	No Upper Limit (depending on bar width and reading distance)	
	Aiming Light	Two Blue LEDs	
	Illumination	Inner LEDs: Four White and Four Red (Wavelength: 625 nm)	
		Outer LEDs: 8 Red	Outer LEDs: 8 Red
	Reading Distance / Field of View	Refer to the Field of View Charts for detail.	
	Pitch Angle (α) *3	$\pm 30^\circ$	
	Skew Angle (β) *3	$\pm 30^\circ$	
Tilt Angle (γ) *3	$\pm 180^\circ$		
Image Capture	Focus	Liquid Lens Autofocus (Wide = 5.2 mm, Medium = 7.7 mm)	
	Resolution	1280 (H) x 960 (V)	752 (H) x 480 (V)
	Color / Monochrome	Monochrome CMOS	Monochrome CMOS
	Shutter	Global Shutter	Global Shutter
	Frames per Second	10 fps	42 fps
	Exposure	50 to 100,000 μ s	
Image Logging	FTP		
Trigger	External Trigger (Edge or Level), Communication Trigger (Ethernet, RS-232C)		
I/O Specifications	Input Signals	Trigger Input: 5-28 V rated (0.16 mA @ 5V DC); New Master: 5 to 28 V rated (0.16 mA @ 5 VDC); Default: 3.3 V rated (0 mA @ 3.3 V)	
	Output Signals	3 Signals : 5 V TTL-compatible, can sink 10 mA and source 10 mA	
Communication	Connectivity	RS-232C, USB 2.0 High Speed, Ethernet over USB/HID	
	Ethernet Specifications	100BASE-TX / 10BASE-T	

Indicator LEDs		PASS (Green), TRIG (Amber), MODE (Amber), LINK (Amber), FAIL (Red), PWR (Green)
Power Supply Voltage		5 VDC +/- 5%
Current Consumption		650 mA at 5 VDC (max.)
Environmental Immunity*4	Ambient Temperature Range	Operating: 0 to 45° C Storage: -50 to 75° C (No Icing or Condensation)
	Ambient Humidity Range	Operating and storage: 5% to 95% (Non-Condensing)
	Ambient Atmosphere	No Corrosive Gases
	Vibration Resistance (Destructive)	Sine Vibration: 10 Hz to 55 Hz, 0.35 mm displacement, 20 cycles/axis. Random Vibration: 20 Hz to 2000 Hz, 6.295 Grms, 30 min/axis
	Shock Resistance (Destructive)	50G, 11 ms, sawtooth profile. 3X in each X, Y, Z axis
	Degree of Protection	IEC 60529 IP54
Weight	Main Body Only	120 g
	Packaging Weight	Approx. 230 g (including packing)
Dimensions	Main Body Dimensions	44.5 (W) × 38.1 (D) × 25.4 (H) mm
	Packaging Dimensions	170 (W) × 117 (D) × 86 (H) mm
LED Safety Standard		IEC 62471-1: 2006 Risk-Exempt Group
Safety Standards		EN 55024:2010, EN 55032:2015 + AC:2016 UL60950-1 BIS, EAC
Materials	Case	Aluminum Diecast, Alumite (Black)
	Reading Window	Acrylic
Software		WebLink

*1. These symbolologies are supported based on wenglor's read capability validation standard. wenglor recommends that validation be performed for each application.

*2. Unless otherwise specified, reading performance is defined with center of field of view, angle $R=\infty$.

*3. Pitch angle

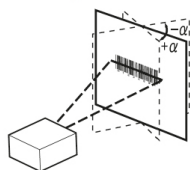

Skew angle

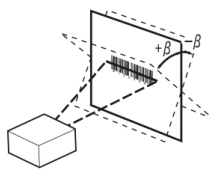

Tilt angle

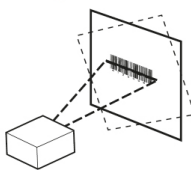

*4. UL certification rating is DC 24 V. Maximum ripple is 200 mV p-p.

C5PC

C5PC		C5PCx0x	C5PCx1x	C5PCx2x
Symbologies *1	1D Symbologies	Code 39, Code 128, BC412, Interleaved 2 of 5, UPC/EAN, Codabar, Code 93, Pharmacode, PLAN-ET, Postnet, Japanese Post, Australian Post, Royal Mail, Intelligent Mail, KIX		
	2D Symbologies	Data Matrix (ECC 0-200), QR Code, Micro QR Code, Aztec Code, DotCode		
	Stacked Symbologies	PDF417, MicroPDF417, GS1 Databar (Composite and Stacked)		
Reading Performance *2	Number of Reading Digits	No Upper Limit (depending on bar width and reading distance)		
	Aiming Light	Two Blue LEDs		
	Illumination	Inner LEDs: Four White and Four Red (Wavelength: 625 nm)		
		Outer LEDs: 8 Red	Outer LEDs: 8 Red	Outer LEDs: 8 White
	Reading Distance / Field of View	Refer to the Field of View Charts for detail.		
	Pitch Angle (α) *3	$\pm 30^\circ$		
	Skew Angle (β) *3	$\pm 30^\circ$		
Tilt Angle (γ) *3	$\pm 180^\circ$			
Image Capture	Focus	Liquid Lens Autofocus (Standard Density = 5.2 mm, High Density = 7.7 mm, Long Range = 16 mm)		
	Resolution	752 (H) x 480 (V)	1280 (H) x 960 (V)	2592 (H) x 1944 (V)
	Color / Monochrome	Monochrome CMOS	Monochrome CMOS	Color CMOS
	Shutter	Global Shutter	Global Shutter	Rolling Shutter
	Frames per Second	60 fps	42 fps	5 fps
	Exposure	50 to 100,000 μ s		
Image Logging	FTP			
Trigger	External Trigger (Edge or Level), Communication Trigger (Ethernet, RS-232C)			
I/O Specifications	Input Signals	Trigger Input; New Master: Bi-Directional, Optoisolated, 4.5-28 V rated (10 mA @ 28 VDC)		
	Output Signals	3 Signals : Bi-Directional, Optoisolated, 1-28V rated, (ICE < 100 mA at 24VDC, current limited by user)		
Communication	Connectivity	RS-232C, Ethernet TCP/IP, EtherNet/IP, PROFINET		
	Ethernet Specifications	100BASE-TX / 10BASE-T		
Indicator LEDs	PASS (Green), TRIG (Amber), MODE (Amber), LINK (Amber), FAIL (Red), PWR (Green)			
Power Supply Voltage	DC24V (Ambient Voltage Range: DC5~30V) *4			
Current Consumption	0.18 A at 24 VDC (max.)			

Environmental Immunity*4	Ambient Temperature Range	Operating: 0 to 45° C Storage: -50 to 75° C (No Icing or Condensation)
	Ambient Humidity Range	Operating and storage: 5% to 95% (Non-Condensing)
	Ambient Atmosphere	No Corrosive Gases
	Vibration Resistance (Destructive)	Sine Vibration: 10 Hz to 55 Hz, 0.35 mm displacement, 20 cycles/axis. Random Vibration: 20 Hz to 2000 Hz, 6.295 Grms, 30 min/axis
	Shock Resistance (Destructive)	50G, 11 ms, sawtooth profile. 3X in each X, Y, Z axis
	Degree of Protection	IEC 60529 IP65 and IP67
Weight	Main Body Only	Approx. 68 g
	Packaging Weight	Approx. 174 g (including packing)
Dimensions	Main Body Dimensions	44.5 (W) × 44.5 (D) × 25.4 (H) mm
	Packaging Dimensions	170 (W) × 117 (D) × 86 (H) mm
LED Safety Standard		IEC 62471-1: 2006 Risk-Exempt Group
Safety Standards		EN 55024:2010, EN 55032:2015 + AC:2016 UL60950-1 BIS, EAC
Materials	Case	Aluminum Diecast, Alumite (Black)
	Reading Window	Acrylic
Software		WebLink

*1. These symbolologies are supported based on wenglor's read capability validation standard. wenglor recommends that validation be performed for each application.

*2. Unless otherwise specified, reading performance is defined with center of field of view, angle R_{∞} .

*3. Pitch angle

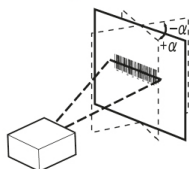

Skew angle

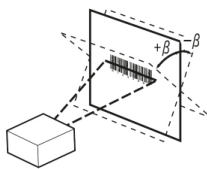

Tilt angle

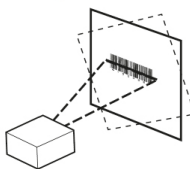

*4. UL certification rating is DC 24 V. Maximum ripple is 200 mV p-p.

1.1. C5PC Field of View and Installation Distance

Field of view / Installation distance

Auto Focus
QSXGA C5PCx2x
Standard Density

Auto Focus
QSXGA C5PCx2x
High Density

Model	Minimum 2D Element Size (mm)
C5PC120	0.13
C5PC121	0.09
C5PC110	0.13
C5PC111	0.09

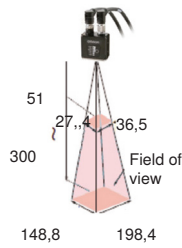
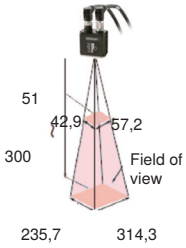
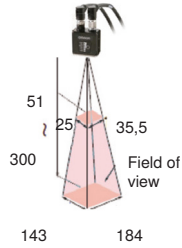
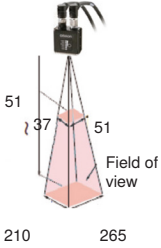

	C5PC102 / C5PC202	C5PC101 / C5PC201	C5PC100 / C5PC200
Field of View	95 x 60 mm	76 x 48 mm	49 x 31 mm
Installation Distance	102 mm	81 mm	50 mm

The LEDs indicate the following conditions:

- **PWR (Green):** On when power is on.
- **FAIL (Red):** On when No Read (Off in Read Cycle).
- **LINK (Orange):** On when communication is established.
- **MODE (Orange):** On in Read Cycle.
- **TRIG (Orange):** On when the TRIG signal (in parallel) is turned on.
- **PASS (Green):** On in Good Read (Off in Read Cycle).



NOTE!

When the Read Rate mode (command) is set, the LED indicator will be lit longer as the Read Rate increases. In Bar Code Configuration mode, the LED indicators flash in order.

1.2. Lighting Mode Table

Lighting Mode	Inner LEDs	Outer LEDs	Off	On	Strobe	Power Strobe Inner LEDs	Power Strobe Outer LEDs	External Strobe
C5KC USB Power	Yes	Yes	Yes	Yes	Yes	No	No	Yes
C5KC External Power	Yes	Yes	Yes	Yes	Yes	No	Yes	Yes
C5PC	Yes	Yes	Yes	Yes	Yes	No	Yes	Yes

1.3. Field of View Charts

Fixed Focus Field of View (mm) – Standard Density

0.3 MP		
Distance (mm)	Width	Height
50	49	32
64	62	39
81	76	49
102	95	60
133	121	78
190	171	109
300	266	170

Fixed Focus Field of View (mm) – High Density

	0.3 MP	
Distance (mm)	Width	Height
50	34	22
64	43	27
81	53	34
102	66	42
133	84	54
190	119	76
300	185	118

Auto focus Field of View (mm) – Standard Density

	0.3 MP – C5PCx03		1.2 MP – C5PCx10		5 MP – C5PCx20	
Distance (mm)	Width	Height	Width	Height	Width	Height
50	51	33	55	41	52	39
100	97	62	103	77	98	73
150	142	90	151	113	144	107
200	187	119	199	149	190	142
250	232	148	247	185	236	176
300	277	177	295	221	282	210

Auto focus Field of View (mm) – High Density

	0.3 MP		1.2 MP – C5PCx11		5 MP – C5PCx21	
Distance (mm)	Width	Height	Width	Height	Width	Height
50	33	21	36	27	34	25
100	63	40	67	50	64	48
150	92	59	98	73	94	70
200	121	77	129	97	123	92
250	151	96	160	120	153	114
300	180	115	191	144	183	136

Long Range Auto focus Field of View (mm)

	1.2 MP – C5PCx12	
Distance (mm)	Width	Height
75	24	18
100	31	23
200	60	45
300	89	67
400	118	88
500	147	110
600	176	132
700	204	153
800	233	175
900	262	197
1000	291	218
1200	349	262
1300	378	283
1400	407	305
1500	436	327

1.4. Readability Tables

The readability tables on the following pages are designed to help users choose the best read-distance, sensor, and lens combination to read their particular code size and code type successfully. The readability tables show the calculated PPE (pixels per element) for a range of typical code sizes at all the C5PC Fixed Focus distances with the Wide, Medium, Long Range lens as well as with the 0.3MP, 1.2MP, and 5MP sensors.

PPE is defined as the following for 1D and 2D codes:

- PPE for 1D codes is the number of pixels across the thinnest bar in the barcode.
- PPE for 2D codes is the number of pixels across a single code cell.

The tables show a color code for readability based on DPM marks (Direct Part Marks) where red means not likely to read, and green means that it should read. The tables also show a range of colors between red and green, while showing the zone where read rates may be acceptable for high-contrast, well-printed labels and can be considered. See the 1D and 2D Code Readability Guidelines below for Minimum and Preferred PPE for both DPM marks and high-contrast labels.



1D Code Readability Guidelines

- **High-Contrast Labels**

- 1.5 pixels per thin bar is suggested minimum;
- 2 pixels or more per thin bar is preferred.

- **Direct Part Marks**

- 2 pixels per thin bar is suggested minimum;
- 2.5 pixels or more per thin bar is preferred.

2D Code Readability Guidelines

- **High-Contrast Labels**

- 2.5 – 2.75 pixels per 2D cell is suggested minimum;
- 3.5 – 5 pixels per 2D cell is preferred.

- **Direct Part Marks**

- 3.25 pixels per 2D Cell is suggested minimum;
- 4 – 6 pixels per 2D Cell is preferred.

Readability Table – 0.3 Megapixel

= Maximum Readability
 = Minimum Readability

0.3 Megapixel – Pixels Per Element / Readability Chart																	
Minimum Element Size	Readability of 1D Code at Distance (mm)								Lens	Readability of 2D Code at Distance (mm)							
	50	64	81	102	133	190	300	400		50	64	81	102	133	190	300	400
2 mil	0.7	0.6	0.5	0.4	0.3	0.2	0.1	0.1	Standard Density	0.7	0.6	0.5	0.4	0.3	0.2	0.1	0.1
2.5 mil	0.9	0.7	0.6	0.5	0.4	0.3	0.2	0.1		0.9	0.7	0.6	0.5	0.4	0.3	0.2	0.1
3.3 mil	1.2	1.0	0.8	0.6	0.5	0.4	0.2	0.2		1.2	1.0	0.8	0.6	0.5	0.4	0.2	0.2
5 mil	1.9	1.5	1.2	1.0	0.8	0.5	0.3	0.3		1.9	1.5	1.2	1.0	0.8	0.5	0.3	0.3
7.5 mil	2.8	2.2	1.8	1.5	1.1	0.8	0.5	0.4		2.8	2.2	1.8	1.5	1.1	0.8	0.5	0.4
10 mil	3.7	3.0	2.4	1.9	1.5	1.1	0.7	0.5		3.7	3.0	2.4	1.9	1.5	1.1	0.7	0.5
15 mil	5.6	4.5	3.6	2.9	2.3	1.6	1.0	0.8		5.6	4.5	3.6	2.9	2.3	1.6	1.0	0.8
20 mil	7.4	6.0	4.8	3.9	3.0	2.1	1.4	1.0		7.4	6.0	4.8	3.9	3.0	2.1	1.4	1.0
30 mil	11.1	8.9	7.2	5.8	4.5	3.2	2.1	1.6		11.1	8.9	7.2	5.8	4.5	3.2	2.1	1.6
40 mil	14.9	11.9	9.6	7.8	6.0	4.3	2.8	2.1	14.9	11.9	9.6	7.8	6.0	4.3	2.8	2.1	
2 mil	1.2	1.0	0.8	0.6	0.5	0.3	0.2	0.2	High Density	1.2	1.0	0.8	0.6	0.5	0.3	0.2	0.2
2.5 mil	1.5	1.2	1.0	0.8	0.6	0.4	0.3	0.2		1.5	1.2	1.0	0.8	0.6	0.4	0.3	0.2
3.3 mil	2.0	1.6	1.3	1.0	0.8	0.6	0.4	0.3		2.0	1.6	1.3	1.0	0.8	0.6	0.4	0.3
5 mil	3.0	2.4	1.9	1.6	1.2	0.9	0.6	0.4		3.0	2.4	1.9	1.6	1.2	0.9	0.6	0.4
7.5 mil	4.5	3.6	2.9	2.3	1.8	1.3	0.8	0.6		4.5	3.6	2.9	2.3	1.8	1.3	0.8	0.6
10 mil	5.9	4.8	3.8	3.1	2.4	1.7	1.1	0.8		5.9	4.8	3.8	3.1	2.4	1.7	1.1	0.8
15 mil	8.9	7.2	5.8	4.7	3.6	2.6	1.7	1.2		8.9	7.2	5.8	4.7	3.6	2.6	1.7	1.2
20 mil	11.9	9.5	7.7	6.2	4.8	3.4	2.2	1.7		11.9	9.5	7.7	6.2	4.8	3.4	2.2	1.7
30 mil	17.8	14.3	11.5	9.3	7.3	5.2	3.3	2.5		17.8	14.3	11.5	9.3	7.3	5.2	3.3	2.5
40 mil	23.8	19.1	15.4	12.4	9.7	6.9	4.4	3.3	23.8	19.1	15.4	12.4	9.7	6.9	4.4	3.3	

Readability Table – 1.2 Megapixel

1.2 Megapixel – Pixels Per Element / Readability Chart																	
Minimum Element Size	Readability of 1D Code at Distance (mm)								Lens	Readability of 2D Code at Distance (mm)							
	50	64	81	102	133	190	300	400		50	64	81	102	133	190	300	400
2 mil	1.2	1.0	0.8	0.6	0.5	0.4	0.2	0.2	Standard Density	1.2	1.0	0.8	0.6	0.5	0.4	0.2	0.2
2.5 mil	1.5	1.2	1.0	0.8	0.6	0.4	0.3	0.2		1.5	1.2	1.0	0.8	0.6	0.4	0.3	0.2
3.3 mil	2.0	1.6	1.3	1.1	0.8	0.6	0.4	0.3		2.0	1.6	1.3	1.1	0.8	0.6	0.4	0.3
5 mil	3.1	2.5	2.0	1.6	1.3	0.9	0.6	0.4		3.1	2.5	2.0	1.6	1.3	0.9	0.6	0.4
7.5 mil	4.6	3.7	3.0	2.4	1.9	1.3	0.9	0.6		4.6	3.7	3.0	2.4	1.9	1.3	0.9	0.6
10 mil	6.2	5.0	4.0	3.2	2.5	1.8	1.1	0.9		6.2	5.0	4.0	3.2	2.5	1.8	1.1	0.9
15 mil	9.3	7.4	6.0	4.8	3.8	2.7	1.7	1.3		9.3	7.4	6.0	4.8	3.8	2.7	1.7	1.3
20 mil	12.4	9.9	8.0	6.5	5.0	3.6	2.3	1.7		12.4	9.9	8.0	6.5	5.0	3.6	2.3	1.7
30 mil	18.5	14.9	12.0	9.7	7.5	5.4	3.4	2.6		18.5	14.9	12.0	9.7	7.5	5.4	3.4	2.6
40 mil	24.7	19.8	16.0	12.9	10.1	7.2	4.6	3.5		24.7	19.8	16.0	12.9	10.1	7.2	4.6	3.5
2 mil	1.8	1.4	1.2	0.9	0.7	0.5	0.3	0.2		High Density	1.8	1.4	1.2	0.9	0.7	0.5	0.3
2.5 mil	2.2	1.8	1.4	1.2	0.9	0.6	0.4	0.3	2.2		1.8	1.4	1.2	0.9	0.6	0.4	0.3
3.3 mil	2.9	2.4	1.9	1.5	1.2	0.9	0.5	0.4	2.9		2.4	1.9	1.5	1.2	0.9	0.5	0.4
5 mil	4.5	3.6	2.9	2.3	1.8	1.3	0.8	0.6	4.5		3.6	2.9	2.3	1.8	1.3	0.8	0.6
7.5 mil	6.7	5.4	4.3	3.5	2.7	1.9	1.2	0.9	6.7		5.4	4.3	3.5	2.7	1.9	1.2	0.9
10 mil	8.9	7.2	5.8	4.7	3.6	2.6	1.7	1.2	8.9		7.2	5.8	4.7	3.6	2.6	1.7	1.2
15 mil	13.4	10.7	8.7	7.0	5.4	3.9	2.5	1.9	13.4		10.7	8.7	7.0	5.4	3.9	2.5	1.9
20 mil	17.8	14.3	11.5	9.3	7.3	5.2	3.3	2.5	17.8		14.3	11.5	9.3	7.3	5.2	3.3	2.5
30 mil	26.7	21.5	17.3	14.0	10.9	7.7	5.0	3.7	26.7		21.5	17.3	14.0	10.9	7.7	5.0	3.7
40 mil	35.6	28.6	23.1	18.6	14.5	10.3	6.6	5.0	35.6		28.6	23.1	18.6	14.5	10.3	6.6	5.0

Readability Table – Long Range

Long Range readability is shown out to 1,500 even though Autofocus is only specified out to 1,160. At the longest focus distance, the lens has a very deep depth of field. Large codes can actually be read beyond 2,000 mm.

Long Range 1.2 MP – Pixels Per Element / Readability Chart															
Readability of 1D Code at Distance (mm)															
Min Element Size	100	200	300	400	500	600	700	800	900	1000	1100	1200	1300	1400	1500
2 mil	2.10	1.09	0.73	0.55	0.44	0.37	0.32	0.28	0.25	0.22	0.20	0.19	0.17	0.16	0.15
2.5 mil	2.63	1.36	0.92	0.69	0.55	0.46	0.40	0.35	0.31	0.28	0.25	0.23	0.22	0.20	0.19
3.3 mil	3.47	1.79	1.21	0.91	0.73	0.61	0.52	0.46	0.41	0.37	0.34	0.31	0.28	0.26	0.25
5 mil	5.25	2.72	1.83	1.38	1.11	0.93	0.80	0.70	0.62	0.56	0.51	0.47	0.43	0.40	0.37
7.5 mil	7.88	4.07	2.75	2.07	1.66	1.39	1.19	1.04	0.93	0.84	0.76	0.70	0.65	0.60	0.56
10 mil	10.51	5.43	3.66	2.76	2.22	1.85	1.59	1.39	1.24	1.12	1.02	0.93	0.86	0.80	0.75
15 mil	15.76	8.15	5.49	4.14	3.33	2.78	2.39	2.09	1.86	1.67	1.52	1.40	1.29	1.20	1.12
20 mil	21.02	10.86	7.32	5.53	4.44	3.70	3.18	2.79	2.48	2.23	2.03	1.86	1.72	1.60	1.49
30 mil	31.52	16.30	10.99	8.29	6.65	5.56	4.77	4.18	3.72	3.35	3.05	2.79	2.58	2.40	2.24
40 mil	42.03	21.73	14.65	11.05	8.87	7.41	6.36	5.57	4.96	4.47	4.06	3.73	3.44	3.20	2.98

Readability of 2D Code at Distance (mm)															
Min Element Size	100	200	300	400	500	600	700	800	900	1000	1100	1200	1300	1400	1500
2 mil	2.10	1.09	0.73	0.55	0.44	0.37	0.32	0.28	0.25	0.22	0.20	0.19	0.17	0.16	0.15
2.5 mil	2.63	1.36	0.92	0.69	0.55	0.46	0.40	0.35	0.31	0.28	0.25	0.23	0.22	0.20	0.19
3.3 mil	3.47	1.79	1.21	0.91	0.73	0.61	0.52	0.46	0.41	0.37	0.34	0.31	0.28	0.26	0.25
5 mil	5.25	2.72	1.83	1.38	1.11	0.93	0.80	0.70	0.62	0.56	0.51	0.47	0.43	0.40	0.37
7.5 mil	7.88	4.07	2.75	2.07	1.66	1.39	1.19	1.04	0.93	0.84	0.76	0.70	0.65	0.60	0.56
10 mil	10.51	5.43	3.66	2.76	2.22	1.85	1.59	1.39	1.24	1.12	1.02	0.93	0.86	0.80	0.75
15 mil	15.76	8.15	5.49	4.14	3.33	2.78	2.39	2.09	1.86	1.67	1.52	1.40	1.29	1.20	1.12
20 mil	21.02	10.86	7.32	5.53	4.44	3.70	3.18	2.79	2.48	2.23	2.03	1.86	1.72	1.60	1.49
30 mil	31.52	16.30	10.99	8.29	6.65	5.56	4.77	4.18	3.72	3.35	3.05	2.79	2.58	2.40	2.24
40 mil	42.03	21.73	14.65	11.05	8.87	7.41	6.36	5.57	4.96	4.47	4.06	3.73	3.44	3.20	2.98

Readability Table – 5 Megapixel

5 Megapixel – Pixels Per Element / Readability Chart																	
Minimum Element Size	Readability of 1D Code at Distance (mm)								Lens	Readability of 2D Code at Distance (mm)							
	50	64	81	102	133	190	300	400		50	64	81	102	133	190	300	400
2 mil	1.7	1.4	1.1	0.9	0.7	0.5	0.3	0.2	Standard Density	1.7	1.4	1.1	0.9	0.7	0.5	0.3	0.2
2.5 mil	2.2	1.7	1.4	1.1	0.9	0.6	0.4	0.3		2.2	1.7	1.4	1.1	0.9	0.6	0.4	0.3
3.3 mil	2.8	2.3	1.8	1.5	1.2	0.8	0.5	0.4		2.8	2.3	1.8	1.5	1.2	0.8	0.5	0.4
5 mil	4.3	3.5	2.8	2.3	1.8	1.2	0.8	0.6		4.3	3.5	2.8	2.3	1.8	1.2	0.8	0.6
7.5 mil	6.5	5.2	4.2	3.4	2.6	1.9	1.2	0.9		6.5	5.2	4.2	3.4	2.6	1.9	1.2	0.9
10 mil	8.6	6.9	5.6	4.5	3.5	2.5	1.6	1.2		8.6	6.9	5.6	4.5	3.5	2.5	1.6	1.2
15 mil	12.9	10.4	8.4	6.8	5.3	3.7	2.4	1.8		12.9	10.4	8.4	6.8	5.3	3.7	2.4	1.8
20 mil	17.3	13.9	11.2	9.0	7.0	5.0	3.2	2.4		17.3	13.9	11.2	9.0	7.0	5.0	3.2	2.4
30 mil	25.9	20.8	16.8	13.5	10.5	7.5	4.8	3.6		25.9	20.8	16.8	13.5	10.5	7.5	4.8	3.6
40 mil	34.5	27.7	22.4	18.1	14.1	10.0	6.4	4.8		34.5	27.7	22.4	18.1	14.1	10.0	6.4	4.8
2 mil	2.5	2.0	1.6	1.3	1.0	0.7	0.5	0.3	High Density	2.5	2.0	1.6	1.3	1.0	0.7	0.5	0.3
2.5 mil	3.1	2.5	2.0	1.6	1.3	0.9	0.6	0.4		3.1	2.5	2.0	1.6	1.3	0.9	0.6	0.4
3.3 mil	4.1	3.3	2.7	2.1	1.7	1.2	0.8	0.6		4.1	3.3	2.7	2.1	1.7	1.2	0.8	0.6
5 mil	6.2	5.0	4.0	3.3	2.5	1.8	1.2	0.9		6.2	5.0	4.0	3.3	2.5	1.8	1.2	0.9
7.5 mil	9.3	7.5	6.0	4.9	3.8	2.7	1.7	1.3		9.3	7.5	6.0	4.9	3.8	2.7	1.7	1.3
10 mil	12.5	10.0	8.1	6.5	5.1	3.6	2.3	1.7		12.5	10.0	8.1	6.5	5.1	3.6	2.3	1.7
15 mil	18.7	15.0	12.1	9.8	7.6	5.4	3.5	2.6		18.7	15.0	12.1	9.8	7.6	5.4	3.5	2.6
20 mil	24.9	20.0	16.1	13.0	10.1	7.2	4.6	3.5		24.9	20.0	16.1	13.0	10.1	7.2	4.6	3.5
30 mil	37.4	30.0	24.2	19.5	15.2	10.8	6.9	5.2		37.4	30.0	24.2	19.5	15.2	10.8	6.9	5.2
40 mil	49.8	40.0	32.3	26.0	20.3	14.4	9.2	7.0		49.8	40.0	32.3	26.0	20.3	14.4	9.2	7.0

Reader Dimensions

Dimensions: mm [in.]

C5KC Front

Optical center

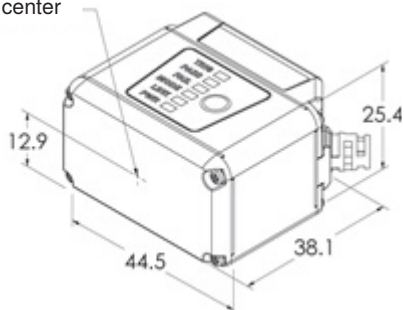

C5KC Base

M3 X .5
5mm DP.
MAX 2X

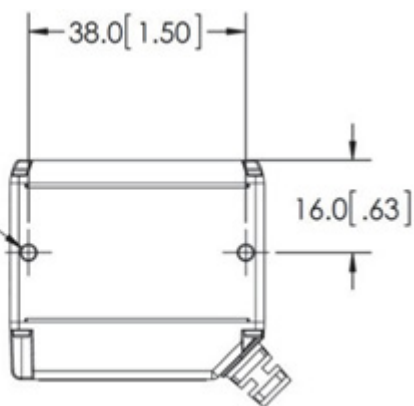

C5KC Top

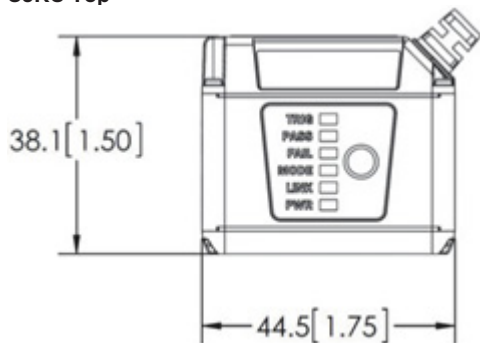

C5KC Side

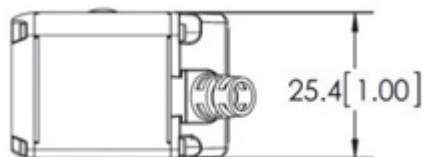

C5PC Front

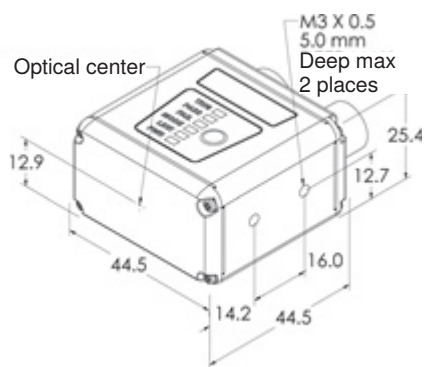

C5PC Base

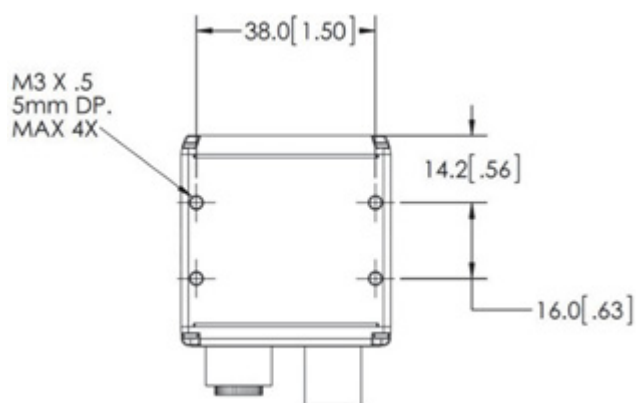

C5PC Top

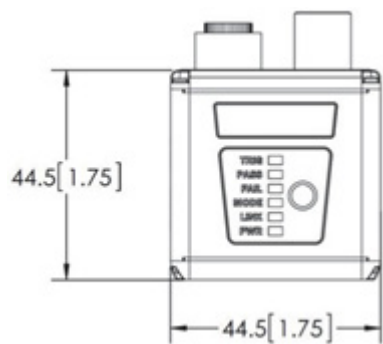

C5PC Side

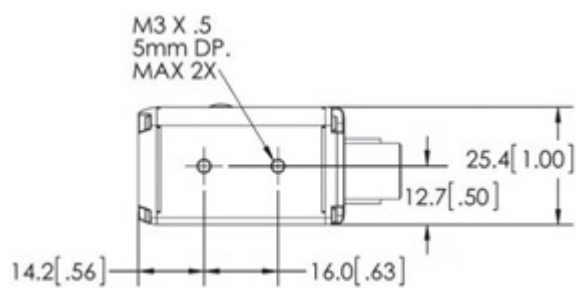

1.5. Grounding and Power

Ground and Shield Considerations

Proper grounding is necessary for operator safety, noise reduction, and the protection of equipment from voltage transients. Buildings, including any steelwork, all circuits, and all junction boxes must be grounded directly to an earth ground in compliance with local and national electrical codes.

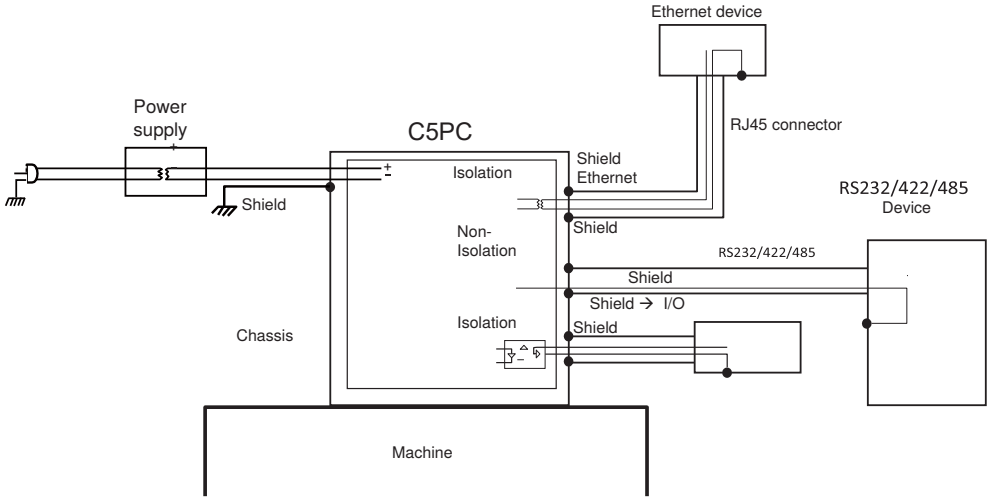

An earth ground is provided through the cable shields and chassis of the camera.

If the C5PC malfunctions due to influence of the environment by shield cables grounded, try any of the ones below.

- Disconnect the chassis and the shield cable of the power supply from the earth.
- Ground the shield cable of the power supply to $- (0V)$.
- Ground any of one part of the shield cable, chassis, or RJ-45 connector of Ethernet cable to earth with D class grounding. Use a Class 2 power supply for the DC source.



NOTE!

In the case of this connection, must not ground the $+ (24V)$ of the power supply. If connected, the device will break down due to a short circuit.

Ground Loops

Ground loops (signal degradation due to different ground potentials in communicating devices) can be eliminated or minimized by ensuring that both the host, imager, and their power supplies are connected to a common earth ground.



NOTE!

If a malfunction occurred to your reader by noise, mount a noise filter (RSAL2001W manufactured by TDK-Lambda Corp.) close to the reader's power-supply terminals and ground the chassis of the filter.

Expected Power and Ground Connections for Proper Operation

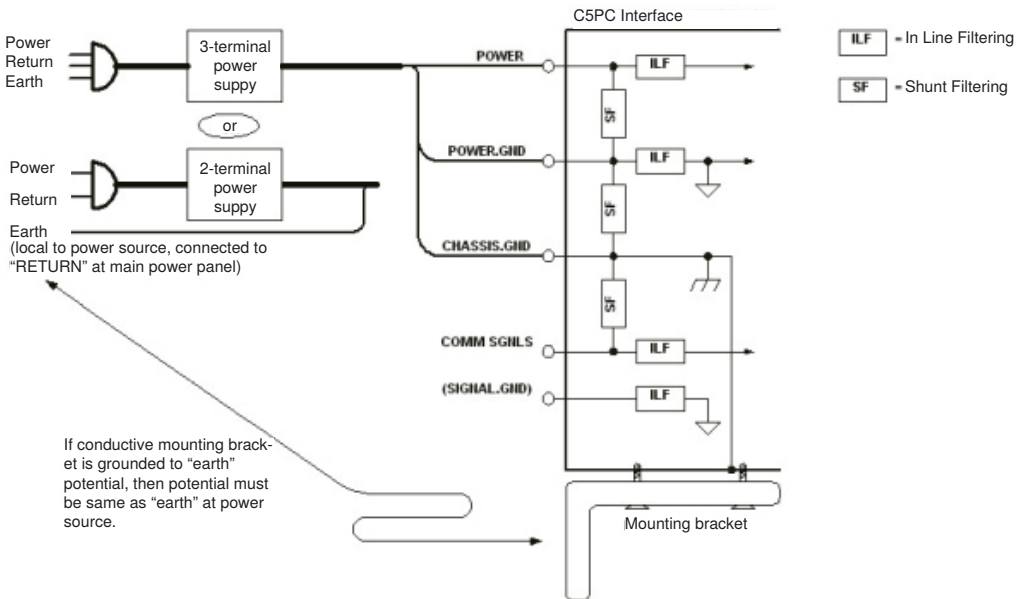

Grounding Notes

- Ensure that mounting bracket "Earth" is at the same potential as power source "Earth".
- Supply "Return" and "Earth" ground must be stable, low-impedance reference points.
- "2-Terminal Power Supply" must still provide an "Earth" connection to the imager.
- "Signal Ground" can be used for communications and/or discrete signal ground reference. It must not be used as Power Ground or Earth Ground

1.6. Accessories and Cables

C5KC / C5PC Accessories

Diffuser

ZNNG030

Spreads out light.

Reduces direct reflection of LEDs.

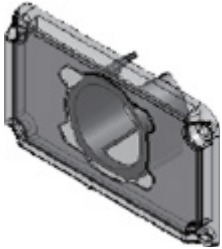

Accessories: Gasket (1)
Phillips-Head Screws (4)

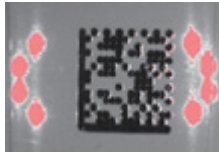

Without Diffuse



With Diffuser

Polarizer

ZNNG031

Reduces glare from specular objects. Passes light from diffuse objects.

Filters out specular (vertical) reflection.

Only the horizontal component of diffuse reflection is "seen" by the reader.

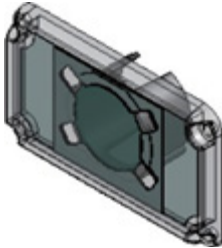

Accessories: Gasket (1)
Phillips-Head Screws (4)



Without Polarizer



With Polarizer

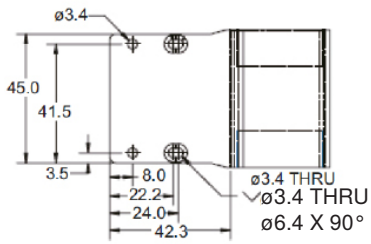
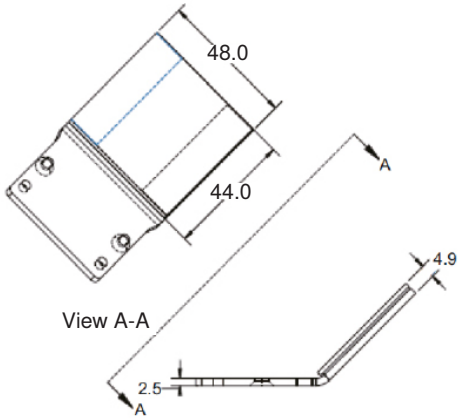

Mounting System (Sold Separately)

Angle-Adjustable Mounting

WFIS03S12VA (Unit: [mm])



Material: Stainless Steel Thickness: 2.5 mm

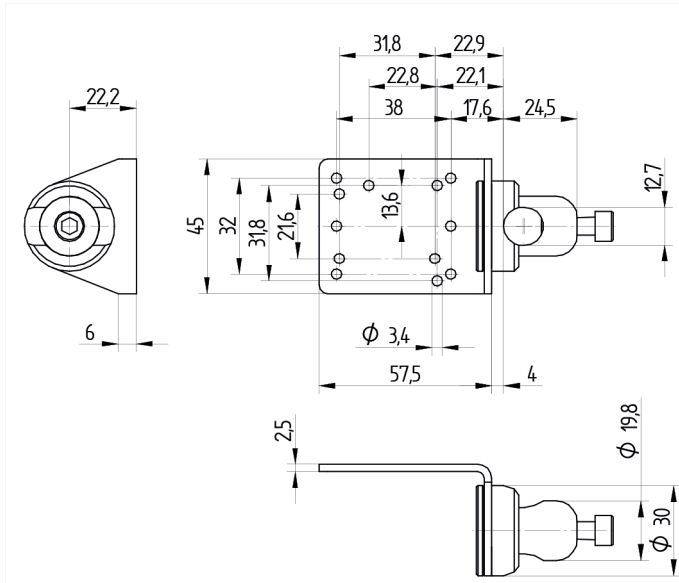

ZAA12NN01 Interconnect Module – Power, Trigger, Smart Light Control

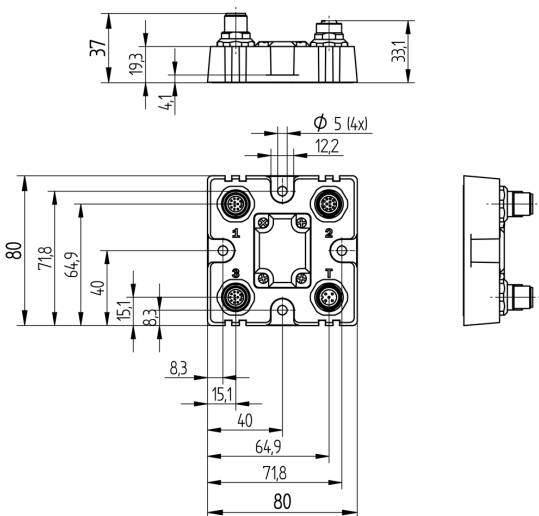
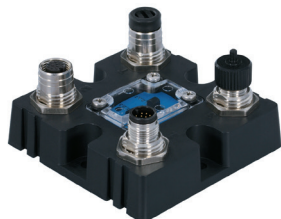

ZDNV007 Cables with Pinouts and Wire Colors

ZDNV007– Cable – USB Breakout with External Power Input – 1 M

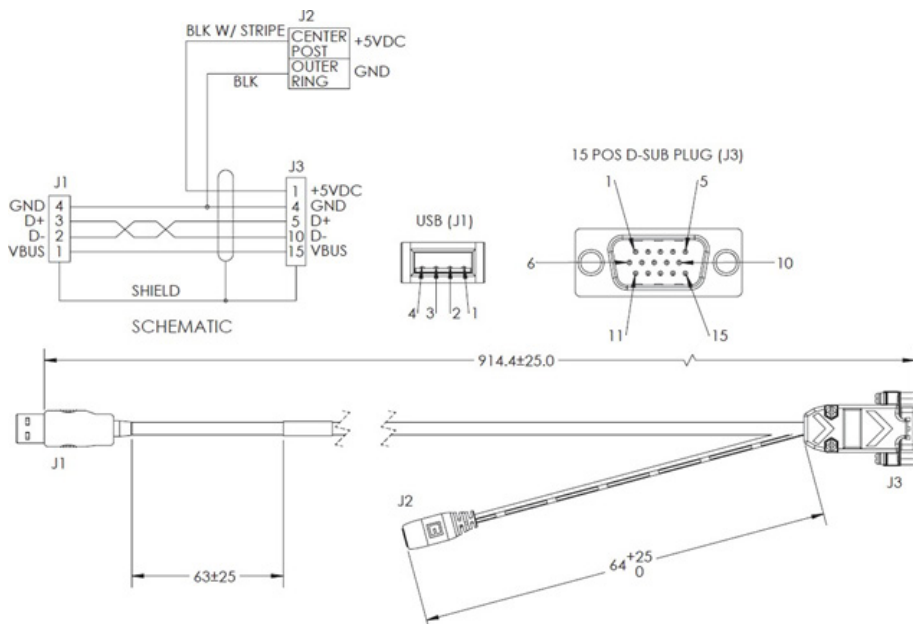

C5PC Cables with Pinouts and Wire Colors

ZCYV00x – Ethernet Communication Cable, Straight Connector, M12 Plug on Camera to RJ45 Connector

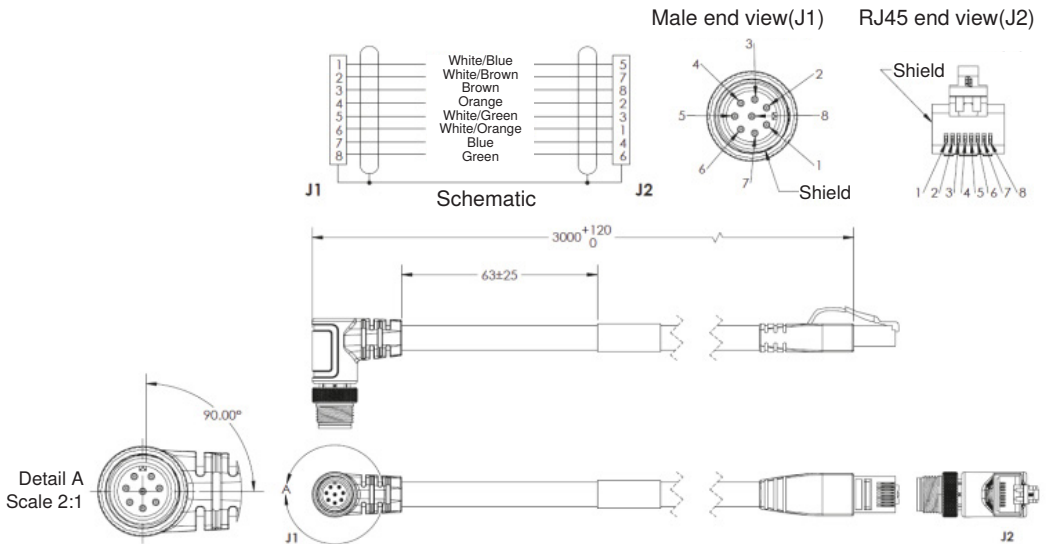
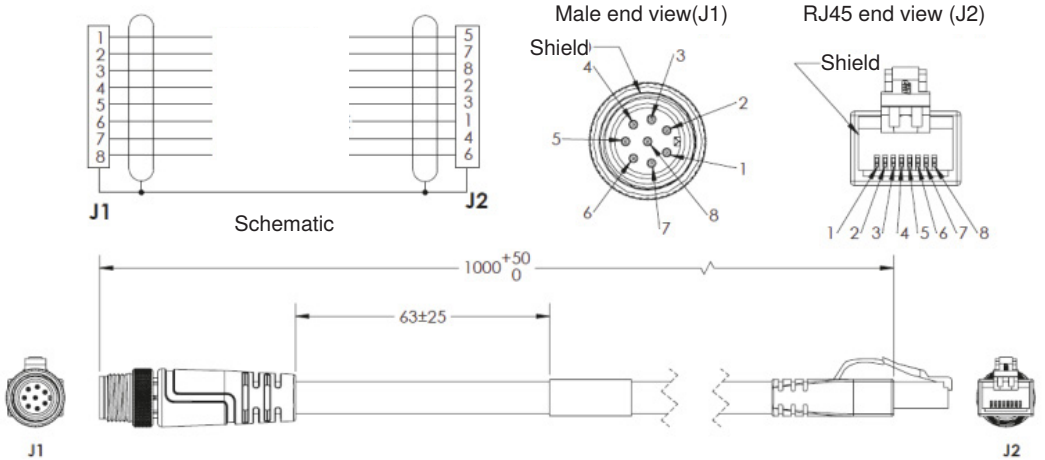

ZDCV00x – Camera to ZAA12NN01 Interconnect Cable, M12 Socket to M12 Plug – 1 M

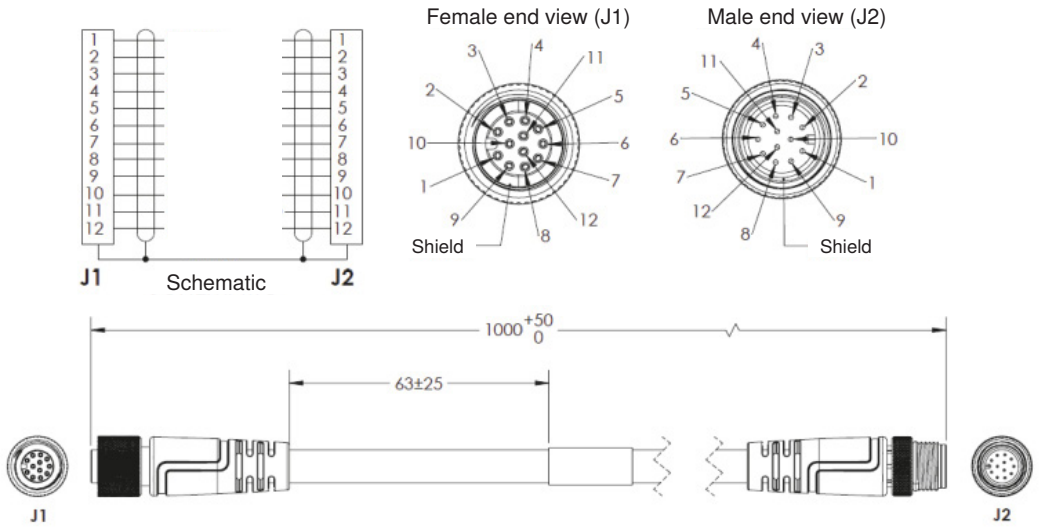

ZDCL001 – M12 to Flying Leads Cable, Straight Power, IO, RS-232, USB

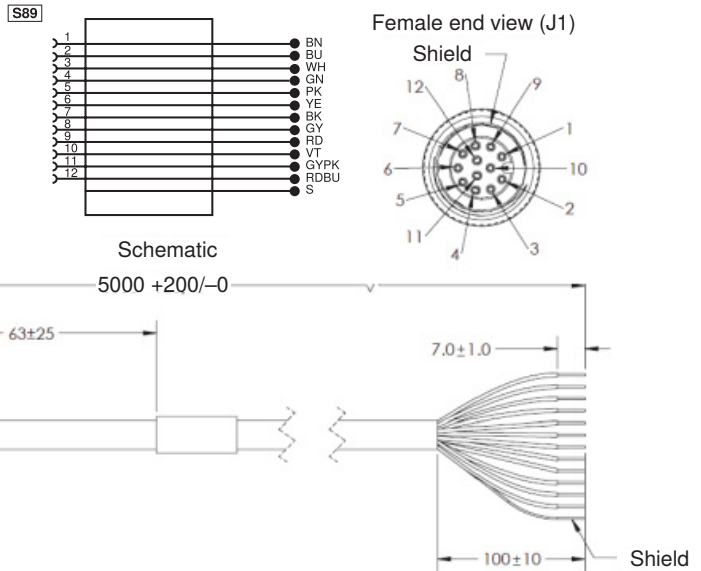

ZDCL004 – M12 to Flying Leads Cable, Right Angle Up* Power, IO, RS-232, USB

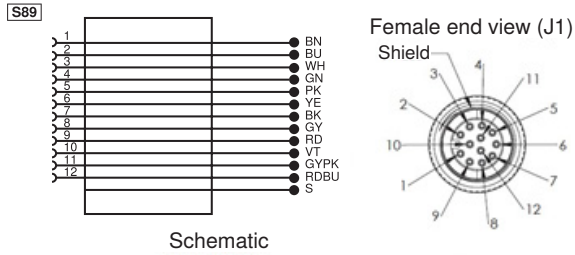

Schematic

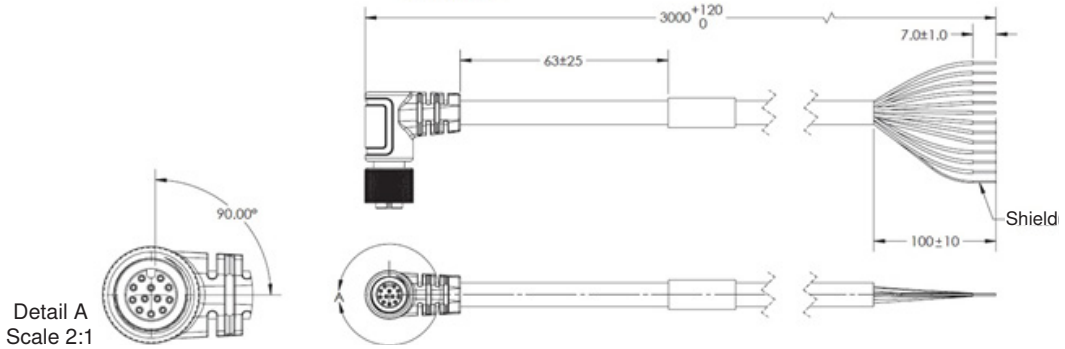

ZDCG003 – Camera to ZAA12NN01 Interconnect Cables with RS-232 Breakout – 0.3 M

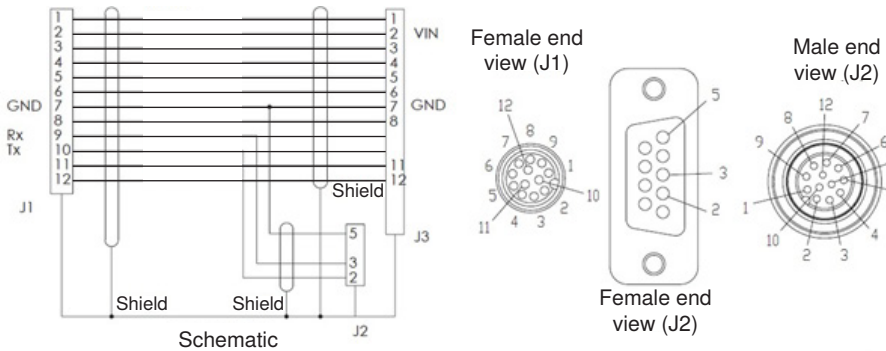

Schematic

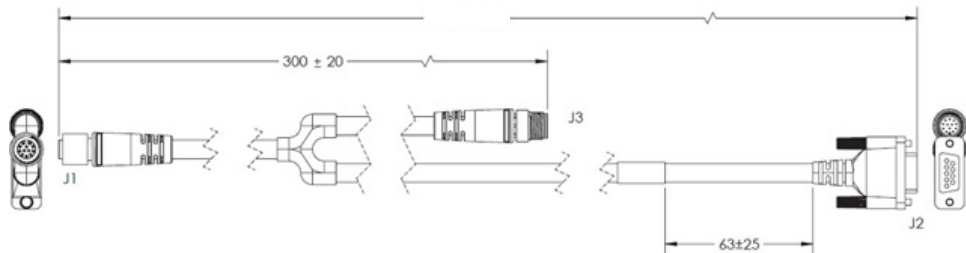

ZDCG005 – Y-Distributor to external illumination and trigger

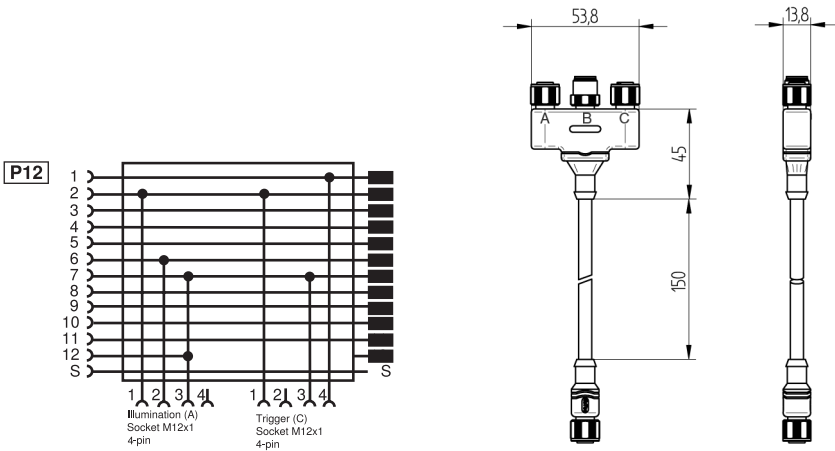

How to set up:

- Connect as described below
- When using a PNP trigger sensor, connect pin 8 (Input Common) to GND
- When using a NPN trigger sensor, connect pin 8 (Input Common) to + 24 V DC
- Parameter settings
 - Read Cycle: Triggered
 - Light Source: External Strobe (Advanced Settings – Camera Setup)
 - Output 3: Use as Ext. Illumination Strobe (Advanced Settings – I/O)

For ZVZF* Lights:

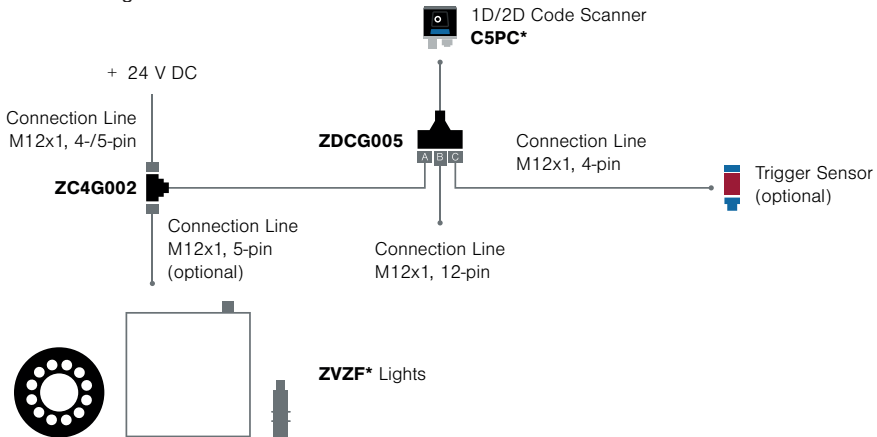

For L* Lights:

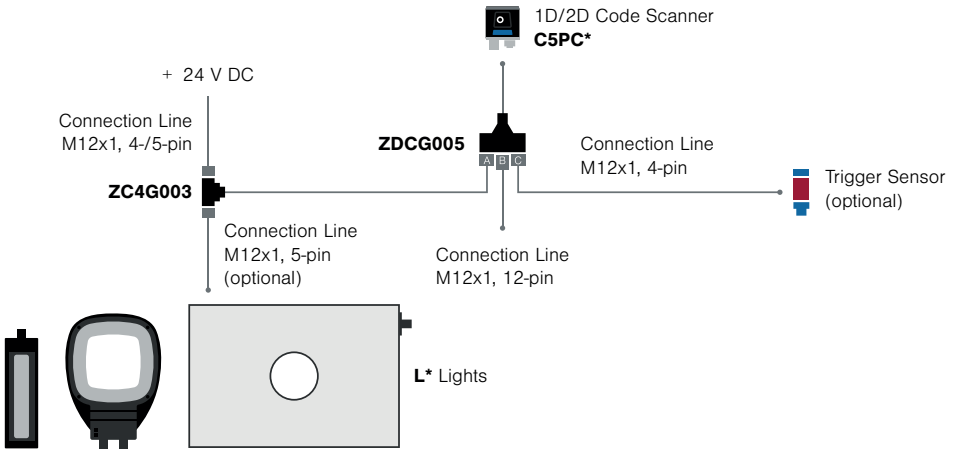

2. Electrical Specifications

This section contains pin assignments for C5KC, and C5PC readers, as well as grounding and isolation information specific to the C5PC.

2.1. C5KC

High-Density 15-Pin D-Sub Socket

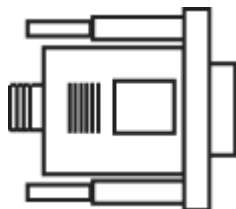

NOTE!

An accessory cable is required between the C5KC's 15-pin corner-exit cable and the host's USB port.

Pin	Function
1	+5 VDC
2	TX232
3	RX232
4	GND
5	D+
6	N/C
7	Output 1+
8	Default+
9	Trigger+
10	D-
11	Output 3+
12	New Master+
13	N/C
14	Output 2+
15	Vbus

2.2. C5PC

M12 Connectors

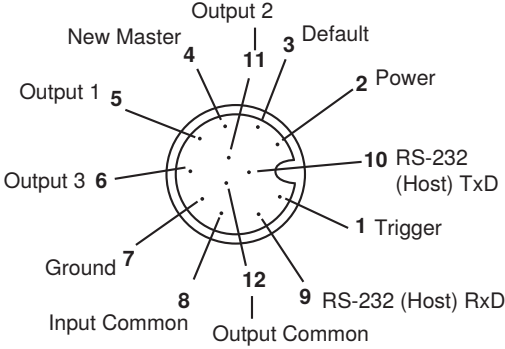

M12 12-Pin Plug

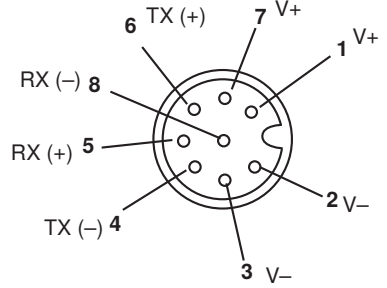

M12 8-Pin Socket (Ethernet)

Grounding and Isolation

Important: Mounting a reader to grounded conductive material may cause communication problems or unreliable operation. If you need to mount the reader to a bracket or plate, be sure that a proper ground connection is available. If a proper ground is not available, electrical isolation of the reader should be performed. Using Nylon Washer and Screws, will ensure that no ground loop or other external electrical noise can occur through the reader.

3. Serial Commands

This section contains information about serial commands for C5PC readers.

Serial Command Format

wenglor readers are controlled by two types of serial commands: configuration commands and utility commands.

- **Rules that apply to both configuration and utility commands**
- Less than '<' and greater than '>' angle bracket characters enclose the commands.
- Commands and data are case sensitive. Characters must be entered as upper or lower case, as specified.

Serial Utility Commands

Serial Utility Commands are sent during operations and are not followed by <A> or <Z>.

Serial Configuration Commands (K Commands)

wenglor's serial configuration commands begin with a single "K" character followed by a 3- digit numeric character, comma-separated command fields, and an initializing command, as follows:

<Knumeric character,data,data,...etc.><initializing command> An initializing command <Z> or <A> may follow the command.

- <Z> initializes the memory and saves for power-on.
- <A> initializes the memory but does not save for power-on.

For example, to enable UPC and save the change for power-on, send <K473,1><Z>.

To change Baud Rate and reset without saving changes for power-on, send <K100,3><A>.

Serial Configuration Command Conventions

- All command fields (except the last) must be followed by a comma (without a space).
- NULL cannot be used. The characters <, >, and , can be used, but only if entered as hex values.
- All fields preceding a modified field must be included.
- If there is no change in preceding fields, then commas alone can be entered in these fields. For example, if only the last field in the following command is changing, <K100,4,1,0,0> can be entered as <K100,,,,0>.
- All fields following a modified field can be omitted. For example, to change Baud Rate only, send <K100,3>.

Concatenating Configuration Commands

Commands can be concatenated (added together) in a single string. For example,

<K145,1><K220,1><A> enables **LRC**, sets **End of Read Cycle** mode to **New Trigger**, and resets the data buffers without saving the changes for power-on.

Serial Command Status Request

To ensure that any command was received and accepted, send the **Show Reader Status** command: <?>.

The status of a specific serial command can be requested by entering the command followed by a question mark. For example, send <K142?> to request the status of **Postamble**.

Entering Control Characters in Serial Commands

To enter control characters within a serial command, hold down the **Ctrl** key while typing the desired character.

Example: To enter a carriage return and line feed (**^M^J**), enter <K141,1,CNTL-m CNTL-j>

4. Communications

This section explains how to set up communications with a host.

4.1. Introduction

With WebLink, configuration changes can be made in the menus and then sent and saved to the reader. The user can also send serial commands to the reader via Terminal.

The following describes the basic flow of the serial (RS-232C) communications.

- Match RS-232C communication parameters (baud rate, parity, data bits, and stop bits) between the reader and the host.
- Send the read command “< >” from the host to reader.
- Send the “read result” from the reader to the host.

The serial (RS-232C) communications use serial commands stated in this manual. For example, “Read” commands are described in Chapter 5 Read Cycle.

The following describes the basic flow of the serial (TCP) communications.

- The reader opens a port (default: 2001) as TCP server at startup.
- The higher connects to the reader as a TCP client.
- The host sends the “read command” “< >” to the reader .
- The reader sends the “read results” to the host.

The serial (TCP) communications use serial commands stated in this manual. For example, “Read” commands are described in Chapter 5 **Read Cycle**.

The following describes the output format of serial (RS-232C, TCP) communications.

<Header> Read strings <Footer>

In default, the header is “None” and the footer is “CR+LF”. The header and footer can be changed with WebLink. (Gear icon - **Advanced - Communications - Preamble/Postamble**)

For example, When reading a code of 12345, the default output data is below.

Output format of serial communications	Output data						
ASCII character notation:	1	2	3	4	5	CR	LF
Hex notation:	31	32	33	34	35	0D	0A

In addition to read strings, coordinate information of a read code and the print quality evaluation information can be added.

4.2. Communications Serial Commands

Host Port Connections	<K100,baud rate,parity,stop bits,data bits>
Ethernet	<K126,status,IP address,subnet,gateway,IP address mode>
Ethernet TCP Ports	<K127,TCP Port 1,TCP Port 2>
Search and Configure Mode	<K128,status,timed window>
EtherNet/IP	<K129,status>
Host Protocol	<K140,protocol,address>
Preamble	<K141,status,preamble characters>
Postamble	<K142,status,postamble characters>
Response Timeout	<K143,response timeout>
LRC Status	<K145,status>
ACK/NAK Options	<K147,RES,REQ,STX,ETX,ACK,NAK>
Polling Mode Options	<K148,RES,REQ,STX,ETX,ACK,NAK>
USB HID/Keyboard	<K149,wenglor Report Enabled,Keyboard Report Enabled,Keyboard Language,USB VCOM Status, UART Status>
EtherNet/IP Byte Swapping Enabled	<K163,status>
PROFINET	<K164,status>
Custom Ethernet Link	<K166,status,transport layer,type,capabilities,IP address,multicast address,port,check connection, timeout (milliseconds),TTL>
USB Mass Storage Driver	<K900,status>

4.3. Custom Ethernet Link

By default, the C5PC reader operates as a server, and communicates with the host over TCP/IP for both commands and data.

Custom Ethernet Link functionality gives you the ability to create an Ethernet interface that is bound to the command processor per your own requirements. You can set the **Transport Layer** to **UDP** or **TCP**, set the message **Type** to **Server** or **Client**, and set **Capabilities** to **Send Only**, **Receive Only**, or **Send/Receive**.

Custom Ethernet Link	
☆ Custom Ethernet Link	Disabled
☆ Transport Layer	TCP
☆ Type	Server
☆ Capabilities	Send/Receive
☆ IP Address	192.168.1.65
☆ Multicast	232.169.247.185
☆ Port	5000
☆ Check Connection	Disabled
☆ Timeout	10000 ms
☆ TTL	128

Custom Ethernet Link is intended for advanced users. This feature permits the establishment of a connection to the reader on any port, using the protocols UDP/IP, TCP, and Multicast on a specified port. A bi-directional communication configuration is available to send commands to the reader, obtain barcode output data, or form a single direction of communication, i.e. sending commands to the reader only, or receiving barcode data from reader only, without having both directions open.

In addition to the ability to move ports, you can also force the connection created by the Custom Ethernet Link to act as a client. Instead of “reaching out” to the reader, it is possible to configure the reader to “go out and connect to” a specified server. This increases flexibility when integrating readers into customer applications. Without this feature, users are limited to static communication into and out of the reader – UDP=80, TCP1=2001, TCP2=2003.

The following section will cover the implementation of how the Custom Ethernet Object is implemented in an Ethernet-based reader. This additional Ethernet-based transport layer allows you to:

- Send “and/or” commands to the device from a specified endpoint;
- Send barcode data to a receiving endpoint i.e. a client or server;
- Handle more than one connecting endpoint connection.

With Custom Ethernet Link functionality, users can configure:

- Transport Layer;
- TCP, UDP, or Multicast;
- Message Type;
- Server or Client;
- The type of data sent and/or received from the device;
- The endpoint to send and receive data, send only barcode data, or receive only commands.

Custom Ethernet Link functionality is bound to the reader's command processor as shown in the figure below. This enables an outside endpoint to still send commands to the device as well as receive data commands and barcode to the receiver.

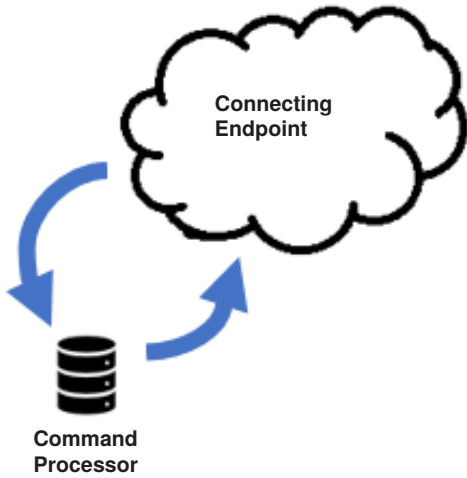

Server Implementation

In cases where the endpoint is configured as a server, the reader is only able to handle 10 simultaneous connections for any transport layer. For TCP, the reader will refuse the connection. UDP and Multicast will simply ignore the connection request due to the connectionless nature of the transport layer.

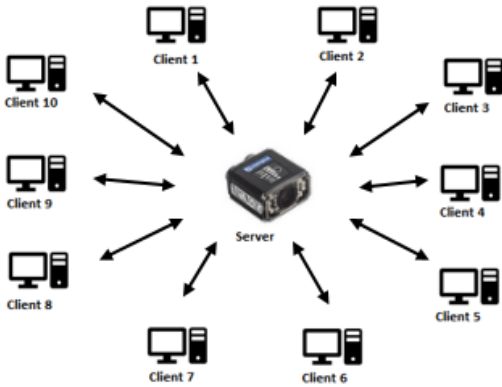

Client Implementation

In cases where the endpoint is configured as a client, the reader is only able to handle one connection to a server. This means the following restrictions apply:

TCP: The reader can only connect to one server when configured as a client.

UDP and Multicast: The reader can only send data out on to one UDP port.

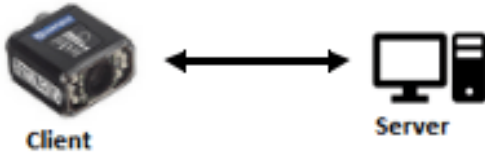

UDP is limited to UDP/IP in order to avoid broadcasting data on the network.

Configuration

This section explains how to configure the Custom Ethernet Object in the reader. The **Custom Ethernet Link K Command** <K166> allows you to configure the Custom Ethernet Object in the reader.

Important: For information about wenglor's proprietary **K Command** syntax, see "1. General Specifications" on page 6 through **Appendix Output Format**.

The following section explains the command parameters that configure the Custom Ethernet Object. Note that each parameter described below corresponds with each parameter shown in the **Custom Ethernet Link** section of WebLink's **Communications** menu.

K Command Format: <K166,status,transport layer,type,capabilities,IP address,multicast address, port,check connection,timeout (milliseconds),TTL>

- **Status**

<K166,status,transport layer,type,capabilities,IP address,multicast address,port,check connection, timeout (milliseconds),TTL>

Status of the Custom Ethernet Object on the device.

0 = Disabled Default – The Custom Ethernet Object is not started.

1 = Enabled – The Custom Ethernet Object has started with the parameters configured.

- **Transport Layer**

<K166,status,transport layer,type,capabilities,IP address,multicast address,port,check connection, timeout (milliseconds),TTL>

The transport layer used by the Custom Ethernet Object to send/receive data. This transport layer obeys the **OSI Model layer 4**. The multicast implementation uses **UDP User Datagram Protocol** as the transport layer.

0 = TCP Default

1 = UDP

2 = Multicast

• **Type**

<**K166**,status,transport layer,**type**,capabilities,IP address,multicast address,port,check connection, timeout (milliseconds),TTL>

This is the how the feature runs on the device and follows the server client model.

0 = Server Default – In server mode the device will be listening on the configured port number. The server can handle up to 10 different connections at one time independent of the transport layer selection. Once the limit has been reached the server will reject other connections.

For Multicast server configuration the user can either use a specified Multicast address or leave the Multicast address to the configured Multicast APIPA Address. This Multicast address is safe to use according to RFC 4607 stating that Multicast ranges from 232.0.0.0 – 232.255.255.255 are okay to use for source specific applications. By default, the unit creates a unique Multicast address in the range of 232.169.xxx.xxx so it does not conflict with other multicast addresses.

1 = Client – In client mode the device will send data to the specified server. The user must configure the IP Address or Multicast Address of the server and the port number that the specified server is listening on. Improper configuration will either yield an error on startup or result in no data being transmitted from the device to the outside world.

• **Capabilities**

<**K166**,status,transport layer,type,**capabilities**,IP address,multicast address,port,check connection, timeout (milliseconds),TTL>

Capabilities is how the user configures the Custom Ethernet Object's read/write settings.

1 = Receive – The device will only receive data from the connecting endpoint. The device will not send data out to any connecting endpoints.

2 = Send – The device will only send data to the connecting endpoint. Any data received is immediately disposed of and not processed.

3 = Send/Receive Default – The device will be able to send and receive data to the connecting endpoint.

• **IP Address**

<**K166**,status,transport layer,type,capabilities,**IP address**,multicast address,port,check connection, timeout (milliseconds),TTL>

If the unit is configured as a client, the **IP Address** is determined by the **Transport Layer**.

TCP – This is the server's IP Address.

UDP – If the server uses UDP/IP, this is the IP Address of the server. Otherwise, it is ignored and the device will send data on the specified port.

Multicast – This parameter is the device's IP Address used to send out the Multicast message. You do not need to configure this parameter.

Default = Unit's IP Address

- **Multicast Address**

<K166,status,transport layer,type,capabilities,IP address,multicast address,port,check connection, timeout (milliseconds),TTL>

In **Server Mode**, this is the multicast address that clients can connect to in order to send/receive data. The port number is the port that the connecting endpoints will use.

In **Client Mode**, this is the multicast address of the server that the device is sending data to. The port number is the port the multicast server is listening on.

Default = 232.169.xxx.xxx Multicast APIPA Address

- **Port**

<K166,status,transport layer,type,capabilities,IP address,multicast address,port,check connection, timeout (milliseconds),TTL>

In **Server Mode**, this is the port number that the connecting endpoints will use to connect to the device.

In **Client Mode**, this is the port number that the server is listening on.

5000 (Default)

- **Check Connection**

<K166,status,transport layer,type,capabilities,IP address,multicast address,port,check connection, timeout (milliseconds),TTL>

This feature is only applicable for **Transport Layer UDP in Client Mode**. The device will transmit **0** length UDP packets to the specified port that the server is listening on. If the device receives an **ICMP Port Destination Not Found**, then it will continue to send **0** length packets in an exponential back-off delay until the device no longer receives ICMP packets. This feature is disabled by default.

0 = Disabled Default

1 = Enabled

- **Timeout (Milliseconds)**

<K166,status,transport layer,type,capabilities,IP address,multicast address,port,check connection, timeout (milliseconds),TTL>

For TCP, this is the timeout before the socket is forcibly closed. For UDP and Multicast, this parameter has no effect.

Default = 10,000

- **TTL**

<K166,status,transport layer,type,capabilities,IP address,multicast address,port,check connection, timeout (milliseconds),TTL>

For Multicast, this is the Time-To-Live counter, or how many hops before the message is discarded by the network. By default, the counter is set to 128 hops, which is more than enough for a typical packet to reach its destination host. It can, however, be configured to last longer or shorter per network requirements.

Default = 128

Configuration Examples

The following examples demonstrate how to configure the Custom Ethernet Object using the **Custom Ethernet Link K Command <K166>** described in the **Configuration** section earlier in this section.

TCP

• Server Mode

Send/Receive Capabilities

<K166,1,0,0,3>

Interpretation of K Command Settings:

- Custom Ethernet Link Enabled Default, Transport Layer = TCP Default;
- Type = Server Default;
- Capabilities = Send/Receive Default

Send-Only Capabilities

<K166,1,0,0,2>

Interpretation of K Command Settings:

- Custom Ethernet Link Enabled Default, Transport Layer = TCP Default;
- Type = Server Default;
- Capabilities = Send

• Client Mode

The following client modes will connect to a TCP Server with IP Address 192.168.188.5 listening on port 5050.



IP: 192.168.188.2
Port: N/A



IP: 192.168.188.5
Port: 5050

Send/Receive Capabilities

<K166,1,0,1,3,192.168.188.5, ,5050>

Interpretation of K Command Settings:

- Custom Ethernet Link Enabled Default, Transport Layer = TCP Default;
- Type = Client;
- Capabilities = Send/Receive Default;
- IP Address = 192.168.188.5;
- Port = 5050

Send-Only Capabilities

<K166,1,0,1,2,192.168.188.5, ,5050>

Interpretation of K Command Settings:

- Custom Ethernet Link Enabled Default, Transport Layer = TCP Default;
- Type = Client;
- Capabilities = Send;
- IP Address = 192.168.188.5, Port = 5050

- **UDP**

- Server Mode**

- Send/Receive Capabilities**

- <K166,1,1,0,3>

- Interpretation of K Command Settings:**

- Custom Ethernet Link Enabled Default, Transport Layer = UDP;
 - Type = Server Default;
 - Capabilities = Send/Receive Default

- Send-Only Capabilities**

- <K166,1,1,0,2>

- Interpretation of K Command Settings:**

- Custom Ethernet Link Enabled Default, Transport Layer = UDP;
 - Type = Server Default;
 - Capabilities = Send

- **Client Mode**

- The following client modes will connect to a UDP Server with IP Address 192.168.188.5 listening on port 5050.



IP: 192.168.188.2
Port: 5050



IP: 192.168.188.5
Port: 5050

- Send/Receive Capabilities**

- <K166,1,1,1,3,192.168.188.5, ,5050>

- Interpretation of K Command Settings:**

- Custom Ethernet Link Enabled Default, Transport Layer = UDP;
 - Type = Client;
 - Capabilities = Send/Receive Default;
 - IP Address = 192.168.188.5;
 - Port = 5050

- Send-Only Capabilities**

- <K166,1,1,1,2,192.168.188.5, ,5050>

- Interpretation of K Command Settings:**

- Custom Ethernet Link Enabled Default, Transport Layer = UDP;
 - Type = Client;
 - Capabilities = Send;
 - IP Address = 192.168.188.5;
 - Port = 5050

Multicast

• Server Mode

The following uses the default Multicast IP Address generated in the device.

Send/Receive Capabilities

<K166,1,2,0,3>

Interpretation of K Command Settings:

- Custom Ethernet Link Enabled Default, Transport Layer = Multicast;
- Type = Server Default;
- Capabilities = Send/Receive Default

Send-Only Capabilities

<K166,1,2,0,2>

Interpretation of K Command Settings:

- Custom Ethernet Link Enabled Default, Transport Layer = Multicast;
- Type = Server Default;
- Capabilities = Send

• Client Mode

The following client modes will connect to a Multicast server with IP Address 224.0.1.90 listening on port 5050.



IP: N/A
Port: 5050



IP: 224.0.1.90
Port: 5050

Send/Receive Capabilities

<K166,1,2,1,3, ,224.0.1.90,5050>

Interpretation of K Command Settings:

- Custom Ethernet Link Enabled Default, Transport Layer = Multicast;
- Type = Client;
- Capabilities = Send/Receive Default;
- IP Address = 224.0.1.90;
- Port = 5050

Send-Only Capabilities

<K166,1,2,1,2, ,224.0.1.90, ,5050>

Interpretation of K Command Settings:

- Custom Ethernet Link Enabled Default, Transport Layer = Multicast;
- Type = Client;
- Capabilities = Send;
- IP Address = 224.0.1.90;
- Port = 5050

4.4. Host Port Connections

The host port can be configured with RS-232 connections.

The following settings define the basic transmission speeds and digital standards that ensure common formatting.

Baud Rate, Host Port

Usage:	Can be used to transfer data faster or to match host port settings.		
Definition:	The rate at which the reader and host transfer data back and forth.		
Serial Cmd:	<K100,baud rate,parity,stop bits,data bits>		
Default:	115.2K		
Options:	0 = 600	1 = 1200	2 = 2400
	3 = 4800	4 = 9600	5 = 19.2K
	6 = 38.4K	7 = 57.6K	8 = 115.2K
	9 = 230.4K		

Parity, Host Port

Usage:	Only changed if necessary to match host setting.		
Definition:	An error detection routine in which one data bit per character is set to 1 or 0 so that the total number of bits in the data field is either even or odd.		
Serial Cmd:	<K100,baud rate,parity,stop bits,data bits>		
Default:	None		
Options:	0 = None	1 = Even	2 = Odd

Stop Bits, Host Port

Usage:	Only changed if necessary to match host setting.		
Definition:	One or two bits added to the end of each character to indicate the end of the character.		
Serial Cmd:	<K100,baud rate,parity,stop bits,data bits>		
Default:	One		
Options:	0 = One	1 = Two	

Data Bits, Host Port

Usage:	Only changed if necessary to match host setting.		
Serial Cmd:	<K100,baud rate,parity,stop bits,data bits>		
Default:	Eight		
Options:	0 = Seven	1 = Eight	

Host Port Protocol

Usage:	In general, the point-to-point protocols will work well in most applications. They require no address and must use RS-232 communications standards.
Definition:	Protocols define the sequence and format in which information is transferred between the reader and the host.
Serial Cmd:	<K140,protocol,address>
Default:	Point-to-Point
Options:	0 = Point-to-Point 4 = ACK/NAK 5 = Polling Mode



NOTE!

In all protocol modes, the preamble <K141> and postamble <K142> character strings can be used to frame the decode data, and both are included in calculating the **LRC** (Longitudinal Redundancy Check).

Point-to-Point (Standard)

Usage:	Used only with RS-232.
Definition:	Standard Point-to-Point requires no address and sends the data to the host whenever it is available, without a request or handshake from the host.
Serial Cmd:	<K140,0>

ACK/NAK

Definition:	See the ACK/NAK Options command <K147>.
Serial Cmd:	<K140,4>

Polling Mode

Definition:	See the ACK/NAK Options command <K148>.
Serial Cmd:	<K140,5>

Poll Address

Serial Cmd:	<K140,protocol,address>
Default:	1
Options:	1 to 50 1 = Poll address 0x1C, Select address 0x1D 2 = Poll address 0x1E, Select address 0x1F ... 50 = Poll address 0x7E, Select address 0x7F

ACK/NAK Options

Definition:	These parameters take effect for ACK/NAK <K140,4> on the main RS-232 port and are completely independent of the Polling Mode Options <K148> . The reader always follows the protocol in both directions (to and from the host). There is no option to disable it from either direction.
Serial Cmd:	<K147,RES,REQ,STX,ETX,ACK,NAK>

RES-NAK Defaults

RES: (Reset)	00 (disabled)
REQ: (Request)	00 (disabled)
STX: (Start of Text)	00 (disabled)
ETX: (End of Text)	00 (disabled)
ACK: (Acknowledge)	06
NAK: (Negative Acknowledge)	15

The following are general outlines of the **ACK/NAK** protocol. Items that are framed by brackets ([]) can either be disabled or enabled. LRC does not include STX, but it does include preamble, postamble, and ETX.

Symbol Data Output

TX to host: [STX] [preamble] SYMBOL DATA [postamble] [ETX] [LRC]

Response from host: ACK/NAK. Sent when LRC, ETX, postamble, or timeout (waiting for more data) are detected (if REQ is disabled) depending on what is enabled.

Commands from Host to Reader

TX to Reader: [STX] <command> [ETX] [LRC]

Response from Reader: ACK/NAK. Sent when LRC, ETX, or command-ending angle bracket '>' are received, depending on what is enabled.

Command Response from Reader to Host

TX to host: [STX] [preamble] COMMAND RESPONSE DATA [postamble] [ETX] [LRC]

Response from host: ACK/NAK. Sent when LRC, ETX, postamble, command-ending angle bracket '>', or timeout (waiting for more data) are detected, depending on what is enabled.

As with **Polling Mode <K140,5>**, the reader can optionally perform the REQ and RES event sequences in ACK/NAK mode. If the sender does not receive an ACK or NAK, it will send REQ to request such a response (if enabled). When the sender receives an ACK, too many NAKs, or times out (if already enabled), it will send a RES (if enabled) to terminate the transaction.



NOTE!

See **ACK/NAK Data Flow Examples** for sample ACK/NAK communication scenarios.

Polling Mode Options

Definition:	<p>These parameters only take effect for Polling Mode <K140,5> on the main RS-232 port and are completely independent of the ACK/NAK Options <K147>.</p> <p>The values of protocol characters can be changed, but the protocol events cannot be disabled. The polling mode address is configured in the <K140> command (see Poll Address).</p> <p>If RS-232 is enabled, <K102,0>, Polling Mode will operate as a Point-to-Point polling protocol. This is because the RS-232 transmitter is always left on when enabled.</p>
Serial Cmd:	<K148,RES,REQ,STX,ETX,ACK,NAK>

RES-NAK Defaults

RES: (Reset)	04
REQ: (Request)	05
STX: (Start of Text)	02
ETX: (End of Text)	03
ACK: (Acknowledge)	06
NAK: (Negative Acknowledge)	15



NOTE!

See **Polling Mode Data Flow Examples** for sample **Polling Mode** communication scenarios.

Ethernet

Enables or disables Ethernet connectivity in the reader. This corresponds to the <K126> command. It requires a <Zrdall> to return to default settings.

IP Address

This is the IP address of the reader when it is in Static IP Address Mode.

Subnet

This is the subnet of the reader when it is in Static IP Address Mode.

Gateway

This is the gateway IP address of the reader when it is in Static IP Address Mode.

IP Address Mode

Determines how the reader's IP address will be defined.

Static

In **Static Mode**, the reader uses the user-defined IP address. This is the default state for the C5PC.

DHCP

In **DHCP Mode**, the reader automatically acquires the IP address, Subnet, and Gateway addresses from a DHCP or BOOTP server.

TCP Port 1

One of two TCP ports for Ethernet communication with the reader. The default setting is 2001.

TCP Port 2

One of two TCP ports for Ethernet communication with the reader. The default setting is **2003**. Changes to this parameter are saved to NOVRAM and are set to default on power on.

A Reset <A> is required for settings to take effect.

Important: Once this setting is Disabled, you will only be able to connect to the reader if you know the IP address and enter it in the IP Address field of the Ethernet TCP/IP connect dialog.

When enabled, **Search and Configure Mode** will find the reader and settings can be changed.

Timed Window

When **Timed Window** is selected, Search and Configure Mode will find the reader and settings can be changed, but only 60 seconds from the last reset. After 60 seconds, Search and Configure Mode will be disabled.

Response Timeout

Usage:	Only used when a response is required from the host. The reader can be set to wait indefinitely by setting Response Timeout to zero.
Definition:	The time that the reader will wait before timing out if ACK , NAK , and ETX are enabled, and a host response is expected.
Serial Cmd:	<K143,response timeout>
Default:	12 (in 1 ms increments)
Options:	0 to 255 (A zero (0) setting causes an indefinite wait.)

LRC (Longitudinal Redundancy Check) Status

Usage:	Used when extra data integrity is required.
Definition:	An error-checking routine that verifies the accuracy of transmissions. It is the exclusive OR of all characters following the STX (start of text) up to and including the ETX (end of text). What this means is that the binary representation of all the characters in a transmission are cumulatively added in a column and each resulting odd integer is assigned a 1 and each even integer a 0 (two 1s = 0, two 0s = 0, a 1 and a 0 = 1). The extra LRC character is then appended to the transmission, and the receiver (usually the host) performs the same addition and compares the results.
Serial Cmd:	<K145,status>
Default:	Disabled
Options:	0 = Disabled 1 = Enabled

4.5. Preamble

Preamble Status

Usage:	Useful for identifying and controlling incoming data. For example, defining the preamble as a carriage return and a line feed causes each decoded message to be displayed on its own line.
Definition:	Defines a one to four character data string that can be added to the front of the decoded data.
Serial Cmd:	<K141,status,preamble character(s)>
Default:	Disabled
Options:	0 = Disabled 1 = Enabled (within any protocol)

Preamble Characters

Serial Cmd:	<K141,status,preamble character(s)>
Default:	^M corresponds to: carriage return .
Options:	To enter control characters within a serial command, hold down the Ctrl key while typing the desired character. Example: <K141,1,CNTL-m> to enter the control character ^M .

4.6. Postamble

Postamble Status

Usage:	Useful for identifying and controlling incoming data. For example, defining the postamble as a carriage return and a line feed causes each decoded message to be displayed on its own line.
Definition:	Defines a one to four character data string that can be added to the front of the decoded data.
Serial Cmd:	<K142,status,postamble character(s)>
Default:	Enabled
Options:	0 = Disabled 1 = Enabled (within any protocol)

Postamble Characters

Serial Cmd:	<K142,status,postamble character(s)>
Default:	^M^J corresponds to: carriage return/line feed .
Options:	To enter control characters within a serial command, hold down the control key while typing the desired character. Example: <K142,1,CNTL-m CNTL-j> to enter ^M^J .

4.7. USB HID/Keyboard

Important: USB HID/Keyboard is available for the C5KC only.

Definition:	These parameters cause the reader to reboot after a <Z> or <A> command. The data packet is structured for input and output as follows: Byte 1 = Report Type (Always 1) Byte 2 = Data Length (Hex Format) Byte 3 – 64 = Data to Command Processor
Serial Cmd:	<K149, wenglor Report Enabled, Keyboard Report Enabled, Keyboard Language, USB VCOM Status, UART Status>

wenglor Report Enabled

Serial Cmd:	<K149, wenglor Report Enabled, Keyboard Report Enabled, Keyboard Language, USB VCOM Status, UART Status>
Default:	0 = Disabled
Options:	0 = Disabled 1 = Enabled

Keyboard Report Enabled

Serial Cmd:	<K149, wenglor Report Enabled, Keyboard Report Enabled , Keyboard Language, USB VCOM Status, UART Status>
Default:	0 = Disabled
Options:	0 = Disabled 1 = Enabled

Keyboard Language

Definition:	Used by the reader to help identify what keyboard layout to use when the keyboard drive is outputting data. If the unit does not have the keyboard layout assigned to this parameter, then it will default to the en-US keyboard layout. On the next page is the list of acceptable languages with predefined keyboard layouts. If they are pre-loaded into the reader's firmware they are shown in bold. All other languages will need to be manually loaded as a keyboard.def file or added to the reader's firmware.
Serial Cmd:	<K149, wenglor Report Enabled, Keyboard Report Enabled, Keyboard Language , USB VCOM Status, UART Status>
Default:	en-US
Options:	ASCII string, up to 25 characters

Keyboard Languages

```
C:\Windows\system32\cmd.exe
#####
#
#           MicroHAWK Installation Options
#
# Would you like to:
# 1: Install the MicroHAWK USB Drivers
# 2: Create WebLink and FTP Drive Shortcuts on Desktop
# 3: Exit
#
#####
?
```

Language	Display Name	Loaded into Firmware
af-ZA	Afrikaans - South Africa	No
sq-AL	Albanian - Albania	No
ar-DZ	Arabic - Algeria	No
ar-BH	Arabic - Bahrain	No
ar-EG	Arabic - Egypt	No
ar-IQ	Arabic - Iraq	No
ar-JO	Arabic - Jordan	No
ar-KW	Arabic - Kuwait	No
ar-LB	Arabic - Lebanon	No
ar-LY	Arabic - Libya	No
ar-MA	Arabic - Morocco	No
ar-OM	Arabic - Oman	No
ar-QA	Arabic - Qatar	No
ar-SA	Arabic - Saudi Arabia	No
ar-SY	Arabic - Syria	No
ar-TN	Arabic - Tunisia	No
ar-AE	Arabic - United Arab Emirates	No
ar-YE	Arabic - Yemen	No
hy-AM	Armenian - Armenia	No
Cy-az-AZ	Azeri (Cyrillic) - Azerbaijan	No
LT-az-AZ	Azeri (Latin) - Azerbaijan	No
eu-ES	Basque - Basque	No
be-BY	Belarusian - Belarus	No
bg-BG	Bulgarian - Bulgaria	No
ca-ES	Catalan - Catalan	No
zh-CN	Chinese - China	No
zh-HK	Chinese - Hong Kong SAR	No
zh-MO	Chinese - Macau SAR	No
zh-SG	Chinese - Singapore	No
zh-TW	Chinese - Taiwan	No
zh-CHS	Chinese (Simplified)	No
zh-CHT	Chinese (Traditional)	No
hr-HR	Croatian - Croatia	No
cs-CZ	Czech - Czech Republic	No
da-DK	Danish - Denmark	No
div-MV	Dhivehi - Maldives	No
nl-BE	Dutch - Belgium	No
nl-NL	Dutch - The Netherlands	No
en-AU	English - Australia	No
en-BZ	English - Belize	No
en-CA	English - Canada	No
en-CB	English - Caribbean	No
en-IE	English - Ireland	No
en-JM	English - Jamaica	No
en-NZ	English - New Zealand	No
en-PH	English - Philippines	No
en-ZA	English - South Africa	No
en-TT	English - Trinidad and Tobago	No
en-GB	English - United Kingdom	No

en-US	English - United States	Yes
en-ZW	English - Zimbabwe	No
et-EE	Estonian - Estonia	No
fo-FO	Faroese - Faroe Islands	No
fa-IR	Farsi - Iran	No
fi-FI	Finnish - Finland	No
fr-BE	French - Belgium	No
fr-CA	French - Canada	Yes
fr-FR	French - France	No
fr-LU	French - Luxembourg	No
fr-MC	French - Monaco	No
fr-CH	French - Switzerland	No
gl-ES	Galician - Galician	No
ka-GE	Georgian - Georgia	No
de-AT	German - Austria	No
de-DE	German - Germany	No
de-LI	German - Liechtenstein	No
de-LU	German - Luxembourg	No
de-CH	German - Switzerland	No
el-GR	Greek - Greece	No
gu-IN	Gujarati - India	No
he-IL	Hebrew - Israel	No
hi-IN	Hindi - India	No
hu-HU	Hungarian - Hungary	No
is-IS	Icelandic - Iceland	No
id-ID	Indonesian - Indonesia	No
it-IT	Italian - Italy	No
it-CH	Italian - Switzerland	No
ja-JP	Japanese - Japan	No
kn-IN	Kannada - India	No
kk-KZ	Kazakh - Kazakhstan	No
kok-IN	Konkani - India	No
ko-KR	Korean - Korea	No
ky-KZ	Kyrgyz - Kazakhstan	No
lv-LV	Latvian - Latvia	No
lt-LT	Lithuanian - Lithuania	No
mk-MK	Macedonian (FYROM)	No
ms-BN	Malay - Brunei	No
ms-MY	Malay - Malaysia	No
mr-IN	Marathi - India	No
mn-MN	Mongolian - Mongolia	No
nb-NO	Norwegian (Bokmål) - Norway	No
nn-NO	Norwegian (Nynorsk) - Norway	No
pl-PL	Polish - Poland	No
pt-BR	Portuguese - Brazil	No
pt-PT	Portuguese - Portugal	No
pa-IN	Punjabi - India	No
ro-RO	Romanian - Romania	No
ru-RU	Russian - Russia	No
sa-IN	Sanskrit - India	No
Cy-sr-SP	Serbian (Cyrillic) - Serbia	No
LT-ar-SP	Serbian (Latin) - Serbia	No

sk-SK	Slovak - Slovakia	No
sl-SI	Slovenian - Slovenia	No
es-AR	Spanish - Argentina	No
es-BO	Spanish - Bolivia	No
es-CL	Spanish - Chile	No
es-CO	Spanish - Colombia	No
es-CR	Spanish - Costa Rica	No
es-DO	Spanish - D.R.	No
es-EC	Spanish - Ecuador	No
es-SV	Spanish - El Salvador	No
es-GT	Spanish - Guatemala	No
es-HN	Spanish - Honduras	No
es-MX	Spanish - Mexico	Yes
es-NI	Spanish - Nicaragua	No
es-PA	Spanish - Panama	No
es-PY	Spanish - Paraguay	No
es-PE	Spanish - Peru	No
es-PR	Spanish - Puerto Rico	No
es-ES	Spanish - Spain	No
es-UY	Spanish - Uruguay	No
es-VE	Spanish - Venezuela	No
sw-KE	Swahili - Kenya	No
sv-FI	Swedish - Finland	No
sv-SE	Swedish - Sweden	No
sy-SY	Syriac - Syria	No
ta-IN	Tamil - India	No
ti-RU	Tatar - Russia	No
te-IN	Telugu - India	No
th-TH	Thai - Thailand	No
tr-TR	Turkish - Turkey	No
uk-UA	Ukrainian - Ukraine	No
ur-PK	Urdu - Pakistan	No
Cy-uz-UZ	Uzbek (Cyrillic) - Uzbekistan	No
LT-uz-UZ	Uzbek (Latin) - Uzbekistan	No
vi-VN	Vietnamese - Vietnam	No

USB VCOM (Virtual CM) Status

Definition:	This command enables the USB Virtual COM Port Driver if your reader supports the driver. The reader will reset so the driver can be used.
Serial Cmd:	< K149 ,wenglor Report Enabled,Keyboard Report Enabled,Keyboard Language, USB VCOM Status ,UART Status>
Options:	0 = Disabled (Default for C5PC) 1 = Enabled (Default for C5KC)

UART Status

Definition:	This command allows the reader to communicate on the reader's UART if the reader is UART-capable. The reader will reset so the UART can be used.
Serial Cmd:	< K149 ,wenglor Report Enabled,Keyboard Report Enabled,Keyboard Language,USB VCOM Status, UART Status >
Options:	0 = Disabled 1 = Enabled (Default for C5KC and C5PC)

EtherNet/IP Byte Swapping Enabled

Definition:	Enables or disables EtherNet/IP byte swapping for decode data.
Serial Cmd:	< K163,status >
Default:	Disabled
Options:	0 = Disabled 1 = Enabled

PROFINET

Definition:	Enables or disables the PROFINET communications protocol.
Serial Cmd:	< K164,status >
Default:	Disabled
Options:	0 = Disabled 1 = Enabled

4.8. Entering ASCII Characters as Hex Values

Commands that require ASCII text fields, such as **Preamble** and **Postamble** commands, can be sent to the reader as hex values.

Serial Cmd Format: **<Knnnh,00-FF>**

To enter ASCII fields as hex values (00 to FF), add a lower-case **h** directly after the command's **K** number, and then enter the hex value that corresponds with the desired ASCII character.

Example:

Consider the **Postamble** command:

Serial Cmd: **<K142,status,postamble character(s)>**

Imagine that your application requires the ASCII character **>** to be the postamble in your symbol decode output.

The ASCII characters **<**, **>**, and **,** can only be entered as hex values. So, to make **>** the postamble in your symbol decode output, enter the **Postamble** command as follows:

<K142h,,3E>

Note that the "status" field contains only a **,**. This is because the only field that is being changed is the "postamble character(s)" field. (See **Serial Configuration Command Conventions** for a more detailed explanation of this command shortcut.)

4.9. USB Mass Storage Driver

Important: USB Mass Storage Driver is available for the C5KC only.

Definition:	Enables USB C5KC readers to display a Mass Storage device on the host PC.
Serial Cmd:	<K900,status>
Default:	Disabled
Options:	0 = Disabled 1 = Enabled

5. Calibration

This section shows the calibration options and explains the different ways that those options can be configured.

5.1. Calibration Serial Commands

Calibration Options <K529,gain,exposure,focus position,symbol type,WOI framing,
WOI margin, line scan height,processing>

5.2. Calibration Overview

Calibration is one of the most powerful features of the C5PC. The calibration process can be initiated by serial command or in the WebLink user interface. When the reader enters calibration, it runs through an optimization cycle that sets the ideal parameters for reading symbols at the highest possible level of performance. Calibration can be specially configured to optimize specific parameters, such as gain, exposure, and symbol type.

5.3. Calibration Options

This command specifies the operation of the calibration feature. The default configuration performs calibration on gain and symbol type. The calibration process optimizes the gain setting for the configured exposure.

Gain

Definition:	When enabled, gain is calibrated to provide the best available image quality and performance. When disabled, gain is fixed and is not part of the calibration process.
Serial Cmd:	K529,gain,exposure,focus position,symbol type,WOI framing,WOI margin, line scan height,processing>
Default:	Quick Calibrate
Options:	0 = Disabled 1 = Enabled (Decode Required) 2 = Quick Calibrate



NOTE!

If you choose to calibrate the reader by sending a <@CAL> command, a decode is also required for the calibration process to be completed successfully.

Disabled

When disabled, gain is fixed and is not part of the calibration process.

Enabled

When enabled, gain is calibrated to provide the best image quality and performance for the symbol present in the field of view. Calibration requires that a decodable symbol be placed in the field of view, as feedback from the symbol decoding process is used to select the best gain setting. If a symbol is not decoded the process will result in a fail condition.

Quick Calibrate

Quick Calibrate uses the automatic gain control (AGC) feature of the image sensor to adjust the gain value such that the current image falls into a desirable region of the image sensor's sensitivity range, ensuring optimal image luminance. The image sensor converges on the optimal gain value within a few image frames.

Exposure

Definition:	Unless the application is static, exposure should be configured based on the application's line speed. The table below is a general guideline for exposure configurations at various line speeds.
Serial Cmd:	<K529,gain, exposure ,focus position,symbol type,WOI framing,WOI margin, line scan height,processing>
Default:	Quick Calibrate
Options:	0 = Disabled 1 = Enabled (Decode Required) 2 = Quick Calibrate



NOTE!

If you choose to calibrate the reader by sending a <@CAL> command, a decode is also required for the calibration process to be completed successfully.



NOTE!

This table shows guidelines for exposure settings based on various line speeds. The settings shown depend on the reader's optical configuration and on symbol element size.

Exposure	Line Speed
100,000 – 4,000	Static
4,000 – 1,250	5" / sec
1,250 – 700	10" / sec
700 – 500	15" / sec
500 – 400	20" / sec

Disabled

When disabled, exposure is fixed and is not part of the calibration process.

Enabled

When enabled, exposure is calibrated to provide the best image quality and performance for the symbol present in the field of view. Calibration requires that a decodable symbol be placed in the field of view, as feedback from the symbol decoding process is used to select the best exposure setting. If a symbol is not decoded the process will result in a fail condition. Exposure is enabled by default.

Quick Calibrate

Quick Calibrate uses the automatic exposure control feature of the image sensor to adjust the exposure value such that the current image falls into a desirable region of the image sensor's sensitivity range, ensuring optimal image luminance. The image sensor converges on the optimal exposure value within a few image frames.

Focus Position

Definition:	The reader's focus position can be configured by entering the target distance value, so focus position can usually be configured without calibration. However, if it is necessary to calibrate the focus distance there are two methods: the standard Search Method and a Quick Focus method, both of which are defined below.
Serial Cmd:	<K529,gain,exposure, focus position ,symbol type,WOI framing,WOI margin, line scan height,processing>
Default:	Quick Focus
Options:	0 = Disabled 1 = Enabled (Decode Required) 2 = Quick Focus

Disabled

The focus position is fixed and is not part of the calibration process.

Enabled (Search Method)

Focus position is calibrated to provide the best image quality and performance. This method is a simple search algorithm that cycles through focus settings and configures camera settings to try and locate the desired focus as quickly as possible. This is accomplished when a symbol is decoded. Once a focus distance that produces a successful decode has been located, the algorithm fine tunes the search to locate the inside and outside focal distances. The final focus distance is between the inside and outside values. This method may be time-consuming if the focus is not found on the first pass.

Quick Focus

Quick Focus is quickly locates the focus setting for an object at the center of the field of view. This is accomplished with minimal image processing, by analyzing a histogram of the image frame. Before performing focus calibration, a value for exposure and gain is determined. The process then steps through the focus range of the system capturing the required number of image frames for each focal position. Then a histogram is performed on each image frame, and the histogram results for each focal position are averaged. When the process is finished, the data is analyzed and the optimal focus position is determined.



NOTE!

This method may not work for all applications. This method is not ideal for very small symbols

Symbol Type

Serial Cmd:	<K529,gain,exposure,focus position, symbol type ,WOI framing,WOI margin,line scan height,processing>
Default:	Enabled
Options:	0 = Disabled 1 = Enabled

Disabled

When this feature is disabled, only the current enabled symbologies will be considered during the calibration process.

Enabled

When this feature is enabled, autodiscrimination is in effect during the calibration process. All supported symbologies except PDF417 and Pharmacode will be attempted during calibration. Any new symbologies successfully decoded during calibration will remain enabled at the end of the process. All enabled symbologies will remain enabled. For example, assume that only Code 39 is enabled at the beginning of calibration. If a Code 128 symbol is decoded during calibration, then Code 128 as well as Code 39 will be enabled.

Window of Interest (WOI) Framing

Definition:	If WOI Framing is enabled, the camera's Window of Interest will be set to a full size image when calibration begins. Once a symbol is decoded, the camera WOI will be zoomed in both vertically and horizontally (regardless of which WOI mode is enabled) to include the symbol plus an additional margin. This is done to speed up the calibration process. When a successful calibration is complete, the camera WOI will be adjusted according to the mode enabled. Otherwise, the original WOI configuration will be retained.
Serial Cmd:	<K529,gain,exposure,focus position,symbol type,WOI framing,WOI margin, line scan height,processing>
Default:	Disabled
Options:	0 = Disabled 1 = Row and Column 2 = Row 3 = Column 4 = Straight Line 5 = Straight Line Framed

If WOI framing is not enabled, the current WOI configuration will be used until a symbol has been decoded. After a symbol is decoded, the WOI is framed exactly as it would be if a WOI framing mode was enabled. When calibration completes, the original WOI configuration is restored.

Disabled

When this feature is disabled, the Window of Interest is not modified after the calibration process is complete.

Row and Column

If the calibration process is successful, the Window of Interest will be modified to frame the symbol as well as an additional margin area around the symbol, determined by the **WOI Margin** parameter.

Row

If the calibration process is successful, the Window of Interest rows will be modified to horizontally frame the symbol, plus an additional margin area around the symbol, determined by the WOI Margin parameter.

Column

If the calibration process is successful, the Window of Interest columns will be modified to vertically frame the symbol, plus an additional margin area around the symbol, determined by the WOI Margin parameter.

Straight Line

This feature is intended for use with linear symbologies. If the calibration process is successful, the orientation of the symbol is determined and the Window of Interest is modified according to the symbol orientation. The scan line orientation is determined to be vertical if the symbol tilt is between 225° and 315° , or between 45° and 135° . Otherwise, the scan line will be horizontal.

If the symbol is vertical, the image column size will be set by the scan height parameter, and will be configured for full row resolution. If the symbol is horizontal, the image row size will be set by the scan height parameter, and will be configured for full column resolution. The scan line will be centered in the middle of the symbol. If the symbol is tilted such that the scan line will not pass completely through the symbol, the scan width will be adjusted to include the entire symbol. Refer to the diagram below:

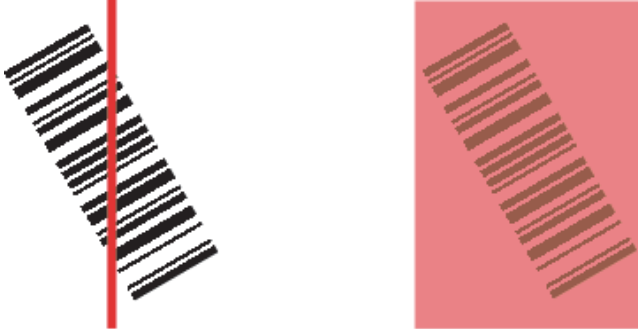

Straight Line Framed

This parameter is the same as "Straight Line", except that the Window of Interest will also frame the scan line on the symbol length as well. The scan line includes the symbol plus an additional margin area determined by the WOI Margin parameter.

Window of Interest (WOI) Margin

Definition:	Sets the margin size that is applied to the calibrated symbol. This parameter is expressed in number of pixels. If the margin causes the image to exceed the maximum image size, it will be reduced accordingly.
Serial Cmd:	<K529,gain,exposure,focus position,symbol type,WOI framing, WOI margin , line scan height,processing>
Default:	75 (pixels)
Options:	20 to 1280

Line Scan Height

Definition:	This parameter is only used with the Straight Line modes. It sets the scan height of the straight-line image, and it is expressed in number of pixels.
Serial Cmd:	<K529,gain,exposure,focus position,symbol type,WOI framing,WOI margin, line scan height ,processing>
Default:	64 (pixels)
Options:	3 to 1280

Processing

Definition:	This setting defines the amount of time and effort the reader will spend attempting to decode a symbol for each parameter configuration.
Serial Cmd:	<K529,gain,exposure,focus position,symbol type,WOI framing,WOI margin, line scan height, processing >
Default:	Medium
Options:	0 = Low 1 = Medium 2 = High 3 = Definable

Low

The reader will spend a low amount of effort attempting to decode the given symbol for each parameter configuration.

Medium

The reader will spend a medium amount of effort attempting to decode the given symbol for each parameter configuration.

High

The reader will spend a high amount of effort attempting to decode the given symbol for each parameter configuration.

Definable

The processing time for each image frame is defined by Image Processing Timeout.

5.4. Additional Notes about Calibration

The following conditions apply to the reader's calibration process. Some of these items are noted at various points throughout this section, or in other sections of the reader's documentation.

1. If **Window of Interest Framing** is enabled, the WOI will be set to full frame when calibration begins. If **WOI Framing** is disabled, the current WOI configuration will be used for the **Search Pass**.
2. **Image Processing Mode** will not be altered during calibration.
3. If **Symbol Type** is enabled for calibration (**Autodiscriminate**), then Interleaved 2 of 5 **Range Mode Status (Interleaved 2 of 5) <K472>** will be enabled. This allows variable-length Interleaved 2 of 5 symbols to be decoded. If an Interleaved 2 of 5 symbol is decoded during calibration, then code length # 1 will be set to the decoded symbol length at the end of calibration. Otherwise, the symbol lengths will be restored to their original configurations.
4. **Pharmacode** is not calibrated.
5. All symbol types that were enabled before calibration will still be enabled after calibration. For example, if Data Matrix ECC 200 was enabled before calibration, and the calibration routine was performed on a Code 128 symbol, then after calibration is completed both Data Matrix ECC 200 and Code 128 will be enabled.
6. Calibration does not modify the global **Composite** status **<K453>**. The global Composite status must be configured properly before calibration.
7. If the user requires calibration of a **stacked** symbology **<K482>**, **<K483>**, or **<K484>**, that symbology must be enabled and configured appropriately before calibration.
8. The **Search** process will use the configurable Window of Interest for image captures. However, when the search process is completed, the WOI will be reduced to include only the symbol of interest and some additional boundary area.

6. Read Cycle

After you've established communications and completed basic read rate testing, you will need to address the spatial and timing parameters associated with your application. This section explains those parameters.

6.1. Read Cycle Serial Commands Read Cycle Serial Commands

Trigger Mode/Filter Duration	<K200,trigger mode,leading edge trigger filter,trailing edge trigger filter>
Serial Trigger Character	<K201,serial trigger character>
External Trigger State	<K202,external trigger state>
End of Read Cycle	<K220,end of read cycle mode,read cycle timeout>
Decodes Before Output	<K221,good decode(s) needed>
Multisymbol	<K222,number of symbols,multisymbol separator>
Start Trigger Character	<K229,start character>
Stop Trigger Character	<K230,stop character>
Capture Mode	<K241,capture mode,number of rapid captures,rapid capture mode,number of continuous captures,images per read cycle limit,read cycle history limit>
Capture Time	<K242,time before first capture,time between captures 1 and 2,timebetween captures 2 and 3,time between captures 3 and 4,time between captures 4 and 5,time between captures 5 and 6,time between captures 6 and 7,time between captures 7 and 8
Image Storage	<K244,image storage type,image store mode>
Image Processing Timeout	<K245,image processing timeout>

6.2. Read Cycle Setup

Setting up read cycle and triggering parameters will involve a series of decisions based on your particular application, as follows:

1. Select the number of symbols to be read in a single cycle. The reader can read multiple symbols in a single image frame.
2. Decide on the trigger type to be used: if serial, choose a serial character; if external, choose either **Level** or **Edge**.
3. Designate how the read cycle should end (**Timeout, New Trigger, Last Frame**).
4. Select **Capture Mode, Continuous Mode, or Rapid Mode**.
5. Select **Number of Captures** (if in **Rapid Capture Mode**).
6. Set the **Time Before First Capture** and **Time Between Captures**, if any.



NOTE!

The capture rate increases as the frame size decreases.

6.3. Multisymbol

Usage:	Multisymbol is commonly used in shipping applications where a shipping symbol contains individual symbols for part number, quantity, etc. This feature allows on trigger to pick up all the symbols.
Definition:	Multisymbol allows the user to define up to 100 symbols that can be read in a single read cycle.
Conditions:	The following conditions apply: <ul style="list-style-type: none"> • Each symbol must be different to be read, unless in Rapid Capture Mode, configured for “triggered capture”. • The maximum number of characters in a read cycle is 3,000 for all symbols. • All No-Read messages are posted at the end of the data string, unless output filtering is enabled. • If more than one symbol is within the field of view at the same time, symbol data may not be displayed in the order of appearance. • If Matchcode Type is set to Sequential or if Trigger is set to Continuous Read 1 Output, the reader will behave as if Number of Symbols were set to 1, regardless of the user-defined configuration.

Number of Symbols

Definition:	Number of Symbols is the number of different symbols that can be read in a single read cycle.
Serial Cmd:	<K222,number of symbols, multisymbol separator >
Default:	1
Options:	1 to 100

Multisymbol Separator

Usage:	Used to delimit or separate data fields with a user defined character.
Definition:	Any valid ASCII character, inserted between each symbol read when Multisymbol is set to any number greater than 1.
Serial Cmd:	<K222,number of symbols, multisymbol separator >
Default:	, (comma)
Options:	Any available ASCII character.



NOTE!

If No-Read messages are disabled and there are No-Reads occurring, separators will only be inserted between symbol data outputs

6.4. Trigger Mode and Filter Duration

Trigger Mode

Definition:	The Trigger is the event that initiates a read cycle.
	 <p>NOTE! When calibrating the reader or testing read rate, the current trigger setting will be disregarded.</p>
Serial Cmd:	<K200,trigger mode,leading edge trigger filter,trailing edge trigger filter> Default:
Default:	Continuous Read Auto
Options:	0 = Continuous Read 1 = Continuous Read 1 Output 2 = External Level 3 = External Edge 4 = Serial Data 5 = Serial Data and Edge 6 = Continuous Read Auto

Continuous Read

Usage:	Continuous Read is useful in testing symbol readability or reader functions. It is not recommended for normal operations.
Definition:	<p>In Continuous Read, trigger input options are disabled, the reader is always in the read cycle, and it will attempt to decode and transmit every capture. If a single symbol stays within read range for multiple read cycles, its data will be transmitted repeatedly until it leaves the read range.</p> <p>The reader sends replies to serial commands that require responses when symbol data is transmitted, or read cycle timeout is enabled and a timeout occurs and at least one captured image has been processed. Depending on the combination of enabled symbologies, the reader may take longer than the timeout to process a captured image.</p>  <p>NOTE! When to Output and No-Read options have no affect on Continuous Read.</p>
Serial Cmd:	<K200,0>



CAUTION!

In automated environments, Continuous Read 1 Output is not recommended because there is typically no reliable way to verify that a symbol was missed.



NOTE!

If Trigger Mode is set to Continuous Read 1 Output, the reader will behave as if Number of Symbols were set to 1, regardless of the user-defined configuration.

External Level

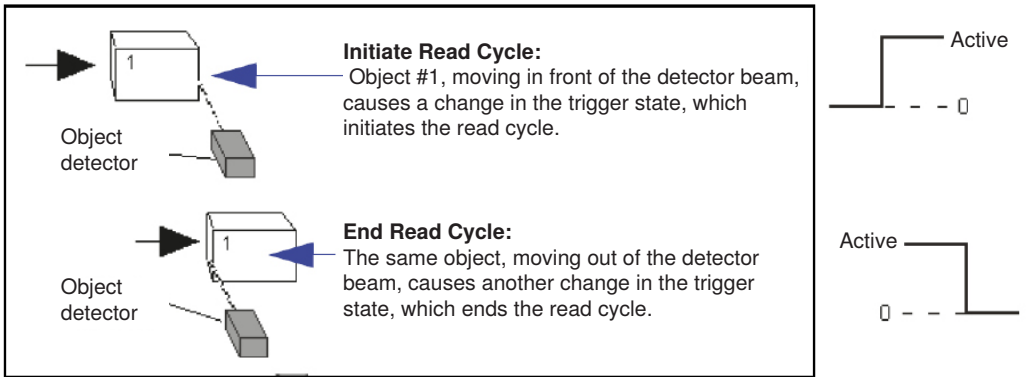

Usage:	This mode is effective in an application where the speeds of the conveying apparatus are variable and the time the reader spends reading each object is not predictable. It also allows the user to determine if a No-Read has occurred.
Definition:	External Level allows the read cycle (active state) to begin when a trigger (change of state) from an external sensing device is received. The read cycle persists until the object moves out of the sensor range and the active trigger state changes again.
Serial Cmd:	<K200,2>

Important: Level and Edge apply to the active logic state (**Active Open** or **Active Closed**) that exists while the object is in a read cycle, between the rising edge and the falling edge. Rising edge is the trigger signal associated with the appearance of an object. Falling edge is the trigger signal associated with the subsequent disappearance of the object.

This applies both to **External Level** and **External Edge**.

External Edge

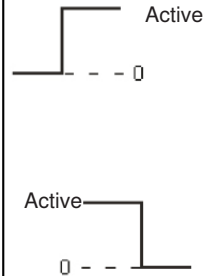
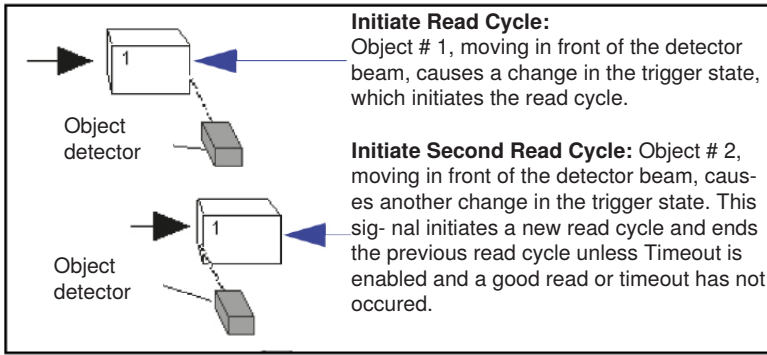

Usage:	This mode is highly recommended in any application where conveying speed is constant, or if spacing, object size, or read cycle timeouts are consistent.
Definition:	External Edge , as with Level, allows the read cycle (active state) to begin when a trigger (change of state) from an external sensing device is received. However, the passing of an object out of sensor range does not end the read cycle. The read cycle ends with a good read output, or, depending on the End of Read Cycle setting, a timeout or new trigger occurs.
Serial Cmd:	<K200,3>

Serial Data

Usage:	Serial Data is effective in a highly controlled environment where the host knows precisely when the object is in the field of view. It is also useful in determining if a No-Read has occurred.
Definition:	In Serial Data, the reader accepts an ASCII character from the host or controlling device as a trigger to start a read cycle. A Serial Data trigger behaves the same as an External Edge trigger.
Serial Cmd:	<K200,4>

Serial Data and Edge

Usage:	Serial Data or External Edge is seldom used but can be useful in an application that primarily uses an external sensing device but occasionally needs to be triggered manually.
Definition:	In this mode the reader accepts either a serial ASCII character or an external trigger pulse to start the read cycle.
Serial Cmd:	<K200,5>

Continuous Read Auto

Definition:	Behaves identically to Continuous Read but maintains optimal self-adjusting photometry and focus parameters. As a result, the photometry parameters (Exposure and Gain) in the <K541> command as well as the focus parameter in the <K525> command are continuously updated with the optimal configuration parameters. In this mode, the illumination does not strobe, but instead is always active, as images are continuously captured. If the <K525,,,Auto Focus Mode> field is set to 1, and if there is a series of no-reads, this mode will self-start a focus pass. <K525,,, # noreads> defines how many no-reads must occur before the focus pass will start.
Serial Cmd:	<K200,6>

Leading Edge Trigger Filter

Usage:	Used to ignore spurious triggers when Trigger Mode is set to External Edge or External Level.
Definition:	To consider a change in state on the trigger input, the level must be stable for the trigger filter duration. In an edge mode, the reader will trigger a read cycle if the active state has been uninterrupted for the entire trigger filter duration. In a level mode, the leading edge is filtered such that on an active edge, the state must be held interrupted for the trigger filter duration before a trigger will occur.
Serial Cmd:	<K200,trigger mode,leading edge trigger filter, trailing edge trigger filter >
Default:	1
Options:	1 to 65535 (Trigger filter range: 32.0 μ s to 2.10 seconds)

Trailing Edge Trigger Filter

Usage:	Used to ignore spurious triggers when Trigger Mode is set to External Edge or External Level.
Definition:	To consider a change in state on the trigger input, the level must be stable for the trigger filter duration. In an edge mode, the reader will trigger a read cycle if the active state has been uninterrupted for the entire trigger filter duration. In a level mode, the trailing edge is filtered such that on the falling edge, the state must be held for the trigger filter duration before the trigger will be deemed inactive.
Serial Cmd:	<K200,trigger mode,leading edge trigger filter, trailing edge trigger filter >
Default:	1
Options:	1 to 65535 (Trigger filter range: 32.0 μ s to 2.10 seconds)

6.5. External Trigger Polarity

Usage:	Allows users to select the trigger polarity that will be used in their application.
Definition:	Determines the active state of the trigger signal applied to the cable input of the reader.
Serial Cmd:	<K202,active state>
Default:	Positive
Options:	0 = Negative 1 = Positive

6.6. Serial Trigger

Usage:	Allows the user to define the trigger character and delimiters that start and stop the read cycle.
Definition:	A serial trigger is considered an online host command and requires the same command format as all host commands. It must be entered within angle bracket delimiters < > or, in the case of non-delimited triggers, it must define individual start and stop characters.

Serial Trigger Character (Delimited)

Usage:	Allows the user to define the trigger character that initiates the read cycle.
Definition:	A single ASCII host serial trigger character that initiates the read cycle. A delimited trigger character is one that either starts or ends the read cycle and is enclosed by delimiters such as < >.
Serial Cmd:	<K201,serial trigger character>
Default:	Space bar
Options:	Any single ASCII character, including control characters, except NUL (0x00 in hex), an existing host command character, or an on-line protocol character. Control characters entered on the command line are displayed in the menu as mnemonic characters.



NOTE!

Serial Data or **Serial Data** or **External Edge** triggering mode must be enabled for **Serial Trigger Character** to take effect.

6.7. Start Trigger Character (Non- Delimited)

Usage:	Useful in applications where different characters are required to start a read cycle.
Definition:	<p>A single ASCII host serial trigger character that starts the read cycle and is not enclosed by delimiters such as < and >.</p> <p>Non-delimited Start characters can be defined and will function according to the trigger event.</p> <p>When defining Start trigger characters, the following rules apply:</p> <ul style="list-style-type: none">• In External Edge the reader looks only for the Start trigger character and ignores any Stop trigger character that may be defined.• In External Level the Start trigger character begins the read cycle and the Stop trigger character ends it. Note that even after a symbol has been decoded and the symbol data transmitted, the reader remains in External Level trigger read cycle until a Stop character is received.• In Serial Data or External Edge trigger mode, either a Start trigger character or a hardware trigger can start an edge trigger read cycle.
Serial Cmd:	<K229,start character>
Default:	NUL (00 in hex) (disabled)
Options:	Two hex digits representing any ASCII character except XON and XOFF .

6.8. Stop Trigger Character (Non- Delimited)

Usage:	Useful in applications where different characters are required to end a read cycle.
Definition:	<p>A single ASCII host serial trigger character that ends the read cycle and is not enclosed by delimiters such as < and >.</p> <p>Non-delimited Stop characters can be defined and will function according to the trigger event.</p> <p>When defining Stop trigger characters, the following rules apply:</p> <ul style="list-style-type: none">• In External Edge the reader looks only for the Start trigger character and ignores any Stop trigger character that may be defined.• In External Level the Start trigger character begins the read cycle and the Stop trigger character ends it. Note that even after a symbol has been decoded and the symbol data transmitted, the reader remains in External Level trigger read cycle until a Stop character is received.• In Serial Data or External Edge trigger mode, either a Start trigger character or a hardware trigger can start an edge trigger read cycle.
Serial Cmd:	<K230,stop character>
Default:	NUL (00 in hex) (disabled)
Options:	Two hex digits representing an ASCII character.

6.9. End of Read Cycle

Definition:	The read cycle is the time during which the reader will attempt to capture and decode a symbol. A read cycle can be ended by a timeout, a new trigger, or by the last frame in a capture sequence or a combination of the above.
--------------------	--

End of Read Cycle Mode



NOTE!

When operating in Continuous Read or Continuous Read 1 Output, the reader is always in the read cycle.

Serial Cmd:	<K220,end of read cycle,read cycle timeout>
Default:	Timeout
Options:	0 = Timeout 1 = New Trigger 2 = Timeout or new Trigger 3 = Last Frame 4 = Last Frame or New Trigger

Timeout

Usage:	Typically used with Serial Data or External Edge and Continuous Read 1 Output . It is effective in highly controlled applications when the maximum length of time between objects can be predicted. It assures that a read cycle ends before the next symbol appears, giving the system extra time to decode and transmit the data to the host.
Definition:	Timeout ends the read cycle, causing the reader to stop reading symbols and send the symbol data or No-Read message when the time set in Timeout elapses (times out), if When to Output is set to End of Read Cycle . If in Continuous Read 1 Output , a timeout initiates a new read cycle and allows the same symbol to be read again. With External Edge, Serial Data, or Serial Data or External Edge enabled, a timeout ends the read cycle and symbol data or a No-Read message is sent to the host. With External Level enabled, the read cycle does not end until the falling edge trigger occurs or a timeout occurs. The next read cycle does not begin until the next rising edge trigger.

New Trigger

Usage:	New Trigger is an effective way to end a read cycle when objects move past the reader at irregular intervals (not timing-dependent).
Definition:	New Trigger ends the current read cycle and initiates a new one when a new trigger occurs. New Trigger refers only to a rising edge trigger. With External Edge, Serial Data, or Serial Data or External Edge enabled, an edge or serial trigger ends a read cycle and initiates the next read cycle. In the case of External Level , a falling edge trigger ends the read cycle but the next read cycle does not begin until the occurrence of the next rising edge trigger.

Timeout or New Trigger

Usage:	Useful in applications that require an alternative way to end the read cycle. For example, if an assembly line should stop completely or the intervals between objects are highly irregular.
Definition:	Timeout or New Trigger is identical to Timeout except that a timeout or a new trigger (whichever occurs first) ends the read cycle.

Last Frame

Usage:	Useful in applications in which the number of captures needed can be defined but the timeout duration varies.
Definition:	Last Frame only applies to Rapid Capture Mode .

Last Frame or New Trigger

Usage:	Useful in applications in which line speeds are irregular and a new labelled object could appear before the last frame in a Rapid Capture sequence.
Definition:	Last Frame or New Trigger is identical to New Trigger except that a new trigger or last frame (whichever occurs first) ends the read cycle.

Read Cycle Timeout

Definition:	Read Cycle Timeout is the duration of the read cycle.
Serial Cmd:	<K220,end of read cycle,read cycle timeout>
Default:	50 (x10 ms)
Options:	1 to 65535

6.10. Capture Mode

Definition:	Capture Mode relates to the way that images are captured and processed.
Serial Cmd:	<K241,capture mode,number of captures,rapid capture mode,number of continuous captures,images per read cycle limit,read cycle history>
Default:	Continuous Capture
Options:	0 = Rapid Capture 1 = Continuous Capture

Rapid Capture

Definition:	In a rapid capture mode, one or multiple captures can be taken at an interval specified by the time-between-captures parameter. In this mode, the only limiting time factor is integration and transfer timing.
--------------------	---

Continuous Capture

Usage:	Continuous Capture is useful in applications with slower line speeds or where symbol spacing may be random or not time-dependent.
Definition:	In Continuous Capture Mode , image captures are taken throughout the read cycle in a multi-buffered format (see diagram below). The reader begins processing the first captured image at the same time that it captures the second image. Captures will continue occurring throughout the read cycle until an end condition occurs, such as a timeout, a new trigger, the last frame in a capture sequence, or a combination of the above.

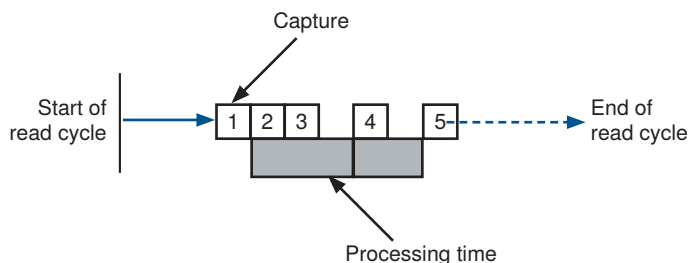

Number of Captures

Usage:	Number of Captures is used to specify the number of captures to be processed in Rapid Capture Mode .
Definition:	Sets the total number of captures that are processed during a read cycle in Rapid Capture Mode . This feature is used in conjunction with Capture Timing parameters to specify the capture sequence of a rapid capture read cycle.
Serial Cmd:	<K241,capture mode,number of captures,rapid capture mode,number of continuous captures,images per read cycle limit,read cycle history>
Default:	1
Options:	1 to 255

Rapid Capture Mode

Definition:	In Rapid Capture Mode , one or multiple captures (as many as 32) can be taken at an interval specified by the time-between-captures parameter. In this mode, the only limiting time factor is integration and transfer timing.
Serial Cmd:	<K241,capture mode,number of captures,rapid capture mode,number of continuous captures,images per read cycle limit,read cycle history>
Default:	Timed Capture
Options:	0 = Timed Capture 1 = Triggered Capture

Timed Capture

Usage:	Timed Rapid Capture is useful in fast-moving applications in which symbols are only in the field of view for a short time and precise timing is required.
Definition:	In Timed Rapid Capture , decoding occurs independent of and simultaneous with capturing, thus allowing precise timing or no delay at all between captures. Also, consecutive captures are regarded as the same symbol if the output data is the same.

Diagram A: No time delay between captures. Shows a sequence of captures starting from the start of the read cycle. A grey bar below the captures indicates processing. An arrow points to the start of the first capture, labeled "Time before first capture".

Diagram B: Time delay between captures. Shows a sequence of captures with gaps between them. The grey bar below the captures indicates processing. Arrows point to the gaps between captures, labeled "Time delay between captures".

Triggered Capture

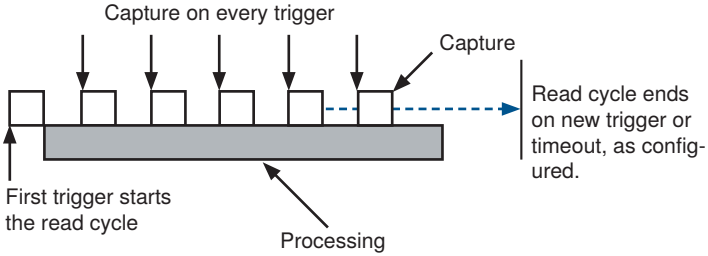
Usage:	Useful in applications where each decode must be treated as a discrete event, regardless of symbol data.
Definition:	<p>The first trigger event starts the read cycle, and subsequent triggers will continue until the predetermined Number of Captures is met, or until the predetermined End of Read Cycle condition is met-- whichever occurs first.</p> <p>NOTE!  If End of Read Cycle is set for New Trigger and the read cycle qualifications have not been met, the read cycle will only end once it receives the first trigger after reaching the predetermined Number of Captures setting.</p> 

Number of Continuous Captures

Definition:	Specifies the number of captures to process in Continuous Capture mode.
Serial Cmd:	<K241,capture mode,number of captures,rapid capture mode, number of continuous captures ,images per read cycle limit,read cycle history>
Default:	2
Options:	1 and 255

Images per Read Cycle Limit

Definition:	Specifies the number of captures to process in a read cycle.
Serial Cmd:	<K241,capture mode,number of captures,rapid capture mode,number of continuous captures, images per read cycle limit ,read cycle history>
Default:	10
Options:	3 and 255

Read Cycle History

Definition:	Specifies the number of images that can be stored in read cycle history.
Serial Cmd:	<K241,capture mode,number of captures,rapid capture mode,number of continuous captures,images per read cycle limit,read cycle history>
Default:	10
Options:	0 and 255

6.11. Capture Timing



NOTE!

Capture Timing applies only to Rapid Capture Mode.

Time Before First Capture

Usage:	In almost any moving line application, a time delay is needed to ensure that a symbol will be in the reader's field of view at the beginning of the capture sequence.
Definition:	Time Before First Capture in a moving line application is the time between an external trigger event and the occurrence of the first capture.
Serial Cmd:	<K242,time before 1 st capture,time between capture 1 and capture 2,,,,,,time between capture 7 and capture 8>
Default:	0
Options:	0 to 65535 (2.097 seconds, in 32 μ S increments)

Time Between Captures

Usage:	This is useful in applications where more than one symbol can appear during a single read cycle (multisymbol), or where line speeds are slow enough that captured frames might overlap or miss a symbol.
Definition:	A time delay can be inserted between individual frame captures in Rapid Capture Mode.
Serial Cmd:	<K242,time before 1 st capture,time between captures [time 1,time 2,...time7] Entering 0s will result in no time between captures. Entering a different value in each field will vary the time delays accordingly.
	<p>NOTE!</p> <p> You must enter time values along with comma separators for each field you want to change. If you omit fields, or enter only commas, the fields will remain as previously set.</p> <p>Important: If the reader is configured to capture more than 8 images, the last (or 8th) delay value will be repeated for the remaining captures.</p>
Default:	0

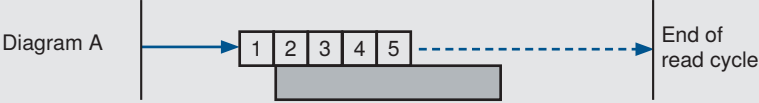
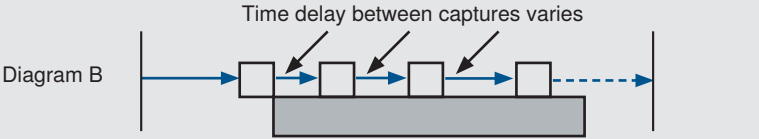
Options:	0 to 65535 (2.097 seconds, in 32 μ S increments) <p>NOTE!</p> <p> Number of Captures and number of frame delays (Time Between Captures) must be the same.</p> <p>Start of read cycle Time delay between captures = 0</p> <p>Diagram A </p> <p>Time delay between captures varies</p> <p>Diagram B </p>
-----------------	---

6.12. Image Processing Timeout

Usage:	Useful in higher speed applications where image processing time is long enough that not all captures have an opportunity to be processed.
Definition:	Specifies the maximum amount of time to process a captured image. When the timeout expires, the image processing is aborted. This timeout works in both Rapid Capture and Continuous Capture modes, as well as with the Configuration Database.
Serial Cmd:	<K245,image processing timeout>
Default:	5000 ms (5 sec.)
Options:	1 to 65535 (in 1 ms increments)

NOTE!



- The timeout period does not include capture time.
- If a timeout occurs during processing and no symbols in the field of view have been decoded, the image will be recorded as a No-Read. For this reason, a longer timeout should be tried to ensure that the symbol is decoded successfully.

6.13. Image Storage

Image Storage Type

Definition:	Allows the user to store images from separate read cycles and to retrieve them later. The number of available slots for storage depends on the mode of operation. If the reader is in Rapid Capture Mode , the number of images that can be stored is equivalent to the maximum number of the rapid count (the current rapid count setting). If the reader is in Continuous Capture Mode , a number of images equivalent to the maximum number of the rapid count minus 3.
Serial Cmd:	<K244,image storage type,image storage mode>
Default:	Disabled/Clear
Options:	0 = Disabled/Clear 1 = Store on No-Read

Disabled/Clear

Upon selection of this option, all saved images will be cleared and the reader will not store images for later viewing.

Store on No-Read

This option will cause the reader to store an image upon exiting the read cycle for retrieval at a later time. If multiple captures are present during the duration of a read cycle, the stored image will be the last image processed for that read cycle. This image is stored in RAM and can be retrieved as long as power is cycled to the reader, and as long as the reader has not been reset via a reset/save sequence. Other commands that can initialize storage in RAM are ones that change capture modes or put the reader in a test capture mode.

Image Storage Mode

Serial Cmd:	<K244,image storage type,image storage mode>
Default:	First Mode
Options:	0 = First Mode 1 = Last Mode

First Mode

This mode allows the reader to store images until the available image memory has been filled. At that point the reader will stop saving additional images. In this mode, you will always have the first image captured, because the saving process stops once memory has been filled.

Last Mode

In this mode, image storage continues after available memory limits are reached. The oldest image in memory is overwritten, so you will always have the most recent stored image.

Image Storage Example

The following example assumes that the reader is in a rapid capture mode of 3 captures.

Number of Symbols:1

Frame # 1: No-Read
Frame # 2: No-Read
Frame # 3: Good Read, Symbol # 1
Read Cycle Result: Good Read
Stored Frame: None

Number of Symbols:1

Frame # 1: No-Read
Frame # 2: No-Read
Frame # 3: No-Read
Read Cycle Result: No-Read
Stored Frame: Frame # 3

Number of Symbols:2

Frame # 1: No-Read
Frame # 2: No-Read
Frame # 3: Good Read, Symbol # 1
Read Cycle Result: No-Read
Stored Frame: Frame # 2

6.14. Decodes Before Output

Definition:	This value specifies the number of times a symbol needs to be read to qualify as a good read.
Serial Cmd:	<K221,good decode(s) needed>
Default:	1
Options:	1 to 255

7. Symbologies

This section describes how to configure the C5PC to decode a wide variety of linear, 2D, and stacked symbologies.

7.1. Symbologies Serial Commands

Composite	<K453,symbology status,separator status,separator character>
Aztec	<K458,status>
Micro QR Code	<K459,status>
Postal Symbologies	<K460,postal symbology type,POSTNET status,PLANET status,USPS4CB status>
Code 39	<K470,status,check character status,check character output status, large inter-character gap,fixed symbol length status, fixed symbol length,full ASCII set>
Codabar	<K471,status,start/stop match,start/stop output,large intercharacter gap,fixed symbol length status,symbol length,check character type,check character output>
Interleaved 2 of 5	<K472,status,check character status,check character output status, symbol length #1, symbol length #2, guard bar status, range mode status>
UPC/EAN	<K473,UPC status,EAN status,supplemental status,separator status, separator character,supplemental type,format UPC-E as UPC-A>
Code 128/EAN 128	<K474,status,fixed symbol length status,fixed symbol length,EAN 128 status,output format,application record separator status,application record separator character,application record brackets,application record padding>
Code 93	<K475,status,fixed symbol length status,symbol length>
PDF417	<K476,status,unused,fixed symbol length status,symbol length>
Pharmacode	<K477,status,fixed bar count status,fixed bar count,minimum bar count,bar width mode,direction,fixed threshold value,background color>
Data Matrix	<K479,ECC 200 status, ECC 000 status,ECC 050 status, ECC 080 status,ECC 100 status,ECC 140 status,ECC 120 status,ECC 130 status>
QR Code	<K480,status>
BC412	<K481,status,check character output,fixed symbol length status, fixed symbol length>
DataBar-14	<K482,status>
DataBar Limited	<K483,status>
DataBar Expanded	<K484,status,fixed symbol length status,fixed symbol length>
MicroPDF417	<K485,status,[unused],fixed symbol length status,fixed symbol length>
DotCode	<K497,status,rotation mode>

7.2. Data Matrix

Usage:	Very useful where information needs to be packed into a small area, and/or where symbols need to be applied directly to the substrate with laser etching, chemical etching, dot peen, or other methods.
Definition:	Data Matrix is a type of Matrix symbology and has subsets ECC 000 - ECC 200. ECC 200 symbols have an even number of rows and an even number of columns. Most of the symbols are square with sizes from 10x10 to 144x144. Some symbols, however, are rectangular, with sizes from 8x18 to 16x48. All ECC 200 symbols can be recognized by the upper right corner module being light (binary 0) instead of dark.

ECC 200

Definition:	When enabled, will decode ECC 200 Data Matrix symbols.
Serial Cmd:	<K479,ECC 200 status,ECC 000 status,ECC 050 status,ECC 080 status, ECC 100 status,ECC 140 status,ECC 120 status,ECC 130 status>
Default:	Enabled  NOTE! This is the only symbol type enabled by default.
Options:	0 = Disabled 1 = Enabled

ECC 000

Definition:	When enabled, will decode ECC 000 symbols.
Serial Cmd:	<K479,ECC 200 status,ECC 000 status,ECC 050 status,ECC 080 status, ECC 100 status,ECC 140 status,ECC 120 status,ECC 130 status>
Default:	Disabled
Options:	0 = Disabled 1 = Enabled

ECC 050

Definition:	When enabled, will decode ECC 050 symbols.
Serial Cmd:	<K479,ECC 200 status,ECC 000 status,ECC 050 status,ECC 080 status, ECC 100 status,ECC 140 status,ECC 120 status,ECC 130 status>
Default:	Disabled
Options:	0 = Disabled 1 = Enabled

ECC 080

Definition:	When enabled, will decode ECC 080 symbols.
Serial Cmd:	< K479 ,ECC 200 status,ECC 000 status,ECC 050 status,ECC 080 status, ECC 100 status,ECC 140 status,ECC 120 status,ECC 130 status>
Default:	Disabled
Options:	0 = Disabled 1 = Enabled

ECC 100

Definition:	When enabled, will decode ECC 100 symbols.
Serial Cmd:	< K479 ,ECC 200 status,ECC 000 status,ECC 050 status,ECC 080 status, ECC 100 status ,ECC 140 status,ECC 120 status,ECC 130 status>
Default:	Disabled
Options:	0 = Disabled 1 = Enabled

ECC 140

Definition:	When enabled, will decode ECC 140 symbols.
Serial Cmd:	< K479 ,ECC 200 status,ECC 000 status,ECC 050 status,ECC 080 status, ECC 100 status, ECC 140 status ,ECC 120 status,ECC 130 status>
Default:	Disabled
Options:	0 = Disabled 1 = Enabled

ECC 120

Definition:	When enabled, will decode ECC 120 symbols.
Serial Cmd:	< K479 ,ECC 200 status,ECC 000 status,ECC 050 status,ECC 080 status, ECC 100 status,ECC 140 status, ECC 120 status ,ECC 130 status>
Default:	Disabled
Options:	0 = Disabled 1 = Enabled

ECC 130

Definition:	When enabled, will decode ECC 130 symbols.
Serial Cmd:	< K479 ,ECC 200 status,ECC 000 status,ECC 050 status,ECC 080 status, ECC 100 status,ECC 140 status,ECC 120 status, ECC 130 status >
Default:	Disabled
Options:	0 = Disabled 1 = Enabled

7.3. Aztec

Usage:	Used in document imaging, railway ticket validation, and some postal applications.
Definition:	A 2D matrix symbology built on a square grid with a square “bull’s-eye” pattern at the center. Aztec can encode up to 3,832 numeric or 3,067 alphabetical characters, or 1,914 bytes of data. The level of Reed-Solomon error correction used with Aztec is configurable, from 5% to 95% of the total data region. The recommended error correction level is 23% of symbol capacity plus codewords.
Serial Cmd:	<K458,status>
Default:	Disabled
Options:	0 = Disabled 1 = Enabled

7.4. QR Code

Usage:	Widely implemented in the automotive industry in Japan and throughout their worldwide supply chain.
Definition:	QR Code is capable of handling numeric, alphanumeric, and byte data as well as kanji and kana characters. Up to 7,366 characters (numeric data) can be encoded using this symbol. Therefore, less space is required to encode the same amount of data in a QR Code symbol than in a conventional symbol, lowering the cost of labelling. Three Position Detection Patterns in the symbol make omnidirectional, ultra-fast reading possible. QR Code has error protection capability. Data can often be restored even if a part of the symbol has become dirty or damaged.
Serial Cmd:	<K480,status>
Default:	Enabled
Options:	0 = Disabled 1 = Enabled

7.5. Micro QR Code

Usage:	Used in various applications that require higher data density than that provided by standard QR Code. Some application examples are automotive inventory, vehicle ID, and mobile phone URL encoding.
Definition:	Micro QR Code is a 2D matrix symbology that comes in 4 different symbol sizes, the largest capable of encoding 35 numeric characters.
Serial Cmd:	<K459,status>
Default:	Enabled
Options:	0 = Disabled 1 = Enabled

7.6. Code 39

Usage:	Code 39 is considered the standard for non-retail 1D symbology.
Definition:	An alphanumeric symbology with unique start/stop code patterns, composed of 9 black and white elements per character, of which 3 are wide.
Serial Cmd:	<K470,status,check character status,check character output status,large inter-character gap,fixed symbol length status,fixed symbol length,full ASCII set>
Default:	Enabled
Options:	0 = Disabled 1 = Enabled

Check Character Status (Code 39)

Serial Cmd:	<K470,status, check character status ,check character output status,large inter-character gap,fixed symbol length status,fixed symbol length,full ASCII set>
Default:	Disabled
Options:	0 = Disabled 1 = Enabled

Check Character Output Status (Code 39)

Usage:	Check Character Output Status , added to the symbol, provides additional data security.
Definition:	When enabled, the check character character is read and compared along with the symbol data. When disabled, symbol data is sent without the check character. <div style="text-align: center;">  <p>NOTE! With Check Character Output Status and an External or Serial trigger option enabled, an invalid check character calculation will cause a No-Read message to be transmitted at the end of the read cycle.</p> </div>
Serial Cmd:	<K470,status,check character status, check character output status ,large inter-character gap,fixed symbol length status,fixed symbol length,full ASCII set>
Default:	Disabled
Options:	0 = Disabled 1 = Enabled

Large Intercharacter Gap (Code 39)

Usage:	Large Intercharacter Gap is helpful for reading symbols that are printed out of specification.
Definition:	When enabled, the reader can read symbols with gaps between symbol characters that exceed three times (3x) the narrow element width.
Serial Cmd:	<K470,status,check character status,check character output status, large inter-character gap ,fixed symbol length status,fixed symbol length,full ASCII set>
Default:	Disabled
Options:	0 = Disabled 1 = Enabled

Fixed Symbol Length Status (Code 39)

Definition:	When enabled, the reader will check the symbol length against the symbol length field. If disabled, any length will be considered valid.
Serial Cmd:	<K470,status,check character status,check character output status,large inter-character gap, fixed symbol length status ,fixed symbol length,full ASCII set>
Default:	Disabled
Options:	0 = Disabled 1 = Enabled

Fixed Symbol Length (Code 39)

Usage:	Fixed Symbol Length helps prevent truncations and increases data integrity by ensuring that only one symbol length will be accepted.
Definition:	Specifies the exact number of characters that the reader will recognize (this does not include start and stop and check characters). The reader ignores any symbology that does not match the specified length.
Serial Cmd:	< K470 ,status,check character status,check character output status,large inter-character gap,fixed symbol length status, fixed symbol length ,full ASCII set>
Default:	10
Options:	1 to 64

Full ASCII Set (Code 39)

Usage:	Must be enabled when reading characters outside the standard character set (0-9, A-Z, etc.) The user must know in advance whether or not to use the Full ASCII Set option. Since Full ASCII Set requires two code words to encode one character, it is less efficient.
Definition:	Standard Code 39 encodes 43 characters; zero through nine, capital "A" through capital "Z", minus symbol, plus symbol, forward slash, space, decimal point, dollar sign, and percent symbol. When Full ASCII Set is enabled, the reader can read the full ASCII character set, from 0 to 255.
Serial Cmd:	< K470 ,status,check character status,check character output status,large inter-character gap,fixed symbol length status,fixed symbol length, full ASCII set >
Default:	Disabled
Options:	0 = Disabled 1 = Enabled

7.7. Code 128/EAN 128

Usage:	Code 128 is a smaller symbology useful in applications with tight spots and high security needs.
Definition:	A very dense alphanumeric symbology. It encodes all 128 ASCII characters, it is continuous, has variable length, and uses multiple element widths measured edge to edge.
Serial Cmd:	< K474 ,status,fixed symbol length status,fixed symbol length,EAN 128 status,output format,application record separator status,application record separator character,application record brackets,application record padding>
Default:	Enabled
Options:	0 = Disabled 1 = Enabled

Fixed Symbol Length Status (Code 128/EAN 128)

Definition:	When enabled, the reader will check the symbol length against the symbol length field. If disabled, any length will be considered a valid symbol.
Serial Cmd:	< K474 ,status, fixed symbol length status ,fixed symbol length,EAN 128 status,output format,application record separator status,application record separator character,application record brackets,application record padding>
Default:	Disabled
Options:	0 = Disabled 1 = Enabled

Fixed Symbol Length (Code 128/EAN 128)

Usage:	Fixed Symbol Length helps prevent truncations and increases data integrity by ensuring that only one symbol length will be accepted.
Definition:	This specifies the exact number of characters that the reader will recognize (this does not include start, stop, and check characters). The reader ignores any symbol not having the specified length.
Serial Cmd:	< K474 ,status,fixed symbol length status,fixed symbol length,EAN 128 status,output format,application record separator status,application record separator character,application record brackets,application record padding>
Default:	10
Options:	1 to 64

EAN 128 Status (Code 128/EAN 128)

Definition:	<p>When this field is disabled, the reader will not check any Code 128 labels for conformance to EAN requirements, or perform any special formatting. When enabled, the reader can read symbols with or without a function 1 character in the first position. If a symbol has a function 1 character in the first position, it must conform to EAN format. Symbols that conform to EAN format will also be subject to the special output formatting options available in this command. If EAN status is required, the reader will only decode symbols that have a function 1 character in the first position and that conform to EAN format. All symbols read will be subject to the special output formatting options available in this command.</p> <p> NOTE! Code 128 status must be enabled for EAN status to be active.</p>
Serial Cmd:	<K474,status,fixed symbol length status,fixed symbol length, EAN 128 status ,output format,application record separator status,application record separator character,application record brackets,application record padding>
Default:	Disabled
Options:	0 = Disabled 1 = Enabled 2 = Required

Output Format (Code 128/EAN 128)

Definition:	<p>In Standard, the reader will not apply special EAN output formatting options. In Application, the reader will apply the special EAN output formatting options to decoded EAN-conforming symbols.</p>
Serial Cmd:	<K474,status,fixed symbol length status,fixed symbol length, EAN 128 status , output format ,application record separator status,application record separator character,application record brackets,application record padding>
Default:	Standard
Options:	0 = Standard 1 = Application

Application Record Separator Status (Code 128/EAN 128)

Definition:	<p>When enabled, an EAN separator will be inserted into the output between fields whenever an EAN-conforming symbol is decoded and EAN output formatting applies.</p>
Serial Cmd:	<K474,status,fixed symbol length status,fixed symbol length,EAN 128 status,output format,application record separator status, application record separator character ,application record brackets,application record padding>
Default:	Disabled
Options:	0 = Disabled 1 = Enabled

Application Record Separator Character (Code 128/EAN 128)

Definition:	This is an ASCII character that serves as an EAN separator in formatted EAN output.
Serial Cmd:	< K474 ,status,fixed symbol length status,fixed symbol length,EAN 128 status,output format,application record separator status, application record separator character ,application record brackets,application record padding>
Default:	,
Options:	Any ASCII character (7 bit)

Application Record Brackets (Code 128/EAN 128)

Definition:	If an EAN-conforming symbol is decoded and EAN formatting applies, this feature places bracket characters around the application identifiers in the formatted output.
Serial Cmd:	< K474 ,status,fixed symbol length status,fixed symbol length,EAN 128 status,output format,application record separator status,application record separator character, application record brackets ,application record padding>
Default:	Disabled
Options:	0 = Disabled 1 = Enabled

Application Record Padding (Code 128/EAN 128)

Definition:	This feature causes the reader to pad variable-length application fields with leading zeroes. This is not done for the last field of a symbol.
Serial Cmd:	< K474 ,status,fixed symbol length status,fixed symbol length,EAN 128 status,output format,application record separator status,application record separator character,application record brackets, application record padding >
Default:	Disabled
Options:	0 = Disabled 1 = Enabled

7.8. BC412

Usage:	Widely used in semiconductor manufacturing. Particularly useful where speed, accuracy, and ease of printing are required.
Definition:	BC412 (Binary Code 412), a proprietary IBM symbology since 1988, is an alphanumeric symbol with a set of 35 characters, each encoded by a set of 4 bars in 12 module positions. All bars have a single width; it is the presence or absence (0) of bars in each of the twelve module positions that make BC412 binary. This symbology is also bi-directional and self-clocking, with a start character and a stop character.
Serial Cmd:	<K481,status,check character output,fixed symbol length status,fixed symbol length>
Default:	Disabled
Options:	0 = Disabled 1 = Enabled

Check Character Output (BC412)

Usage:	Check Character Output , added to the symbol, provides additional security.
Definition:	When enabled, the check character is read and compared along with the symbol data. When disabled, symbol data is sent without the check character.
Serial Cmd:	<K481,status,check character output, fixed symbol length status ,fixed symbol length>
Default:	Disabled
Options:	0 = Disabled 1 = Enabled

Fixed Symbol Length Status (BC412)

Definition:	When enabled, the reader will check the symbol length against the symbol length field. If disabled, any length will be considered valid.
Serial Cmd:	<K481,status,check character output, fixed symbol length status ,fixed symbol length>
Default:	Disabled
Options:	0 = Disabled 1 = Enabled

Fixed Symbol Length (BC412)

Definition:	When enabled, the check character is read and compared along with the symbol data. When disabled, symbol data is sent without the check character.
Serial Cmd:	<K481,status,check character output,fixed symbol length status, fixed symbol length >
Default:	10
Options:	1 to 64

7.9. Interleaved 2 of 5

Usage:	I-2/5 has been popular because it is the most dense symbology for printing numeric characters less than 10 characters in length; however, wenglor does not recommend this symbology for any new applications because of inherent problems such as truncation.
Definition:	A dense, continuous, self-checking, numeric symbology. Characters are paired together so that each character has five elements, two wide and three narrow, representing numbers 0 through 9, with the bars representing the first character and the interleaved spaces representing the second character. (A check character is highly recommended). Important: You must set Symbol Length in order to decode I-2/5 symbols, unless Range Mode is enabled.
Serial Cmd:	<K472,status,check character status,check character output status,symbol length #1,symbol length #2,guard bar status,range mode status>
Default:	Enabled
Options:	0 = Disabled 1 = Enabled

Check Character Status (Interleaved 2 of 5)

Usage:	This option is not typically used, but it can be enabled for additional security in applications where the host requires redundant check character verification.
Definition:	An error correcting routine in which the check character is added.
Serial Cmd:	<K472,status, check character status ,check character output status,symbol length #1,symbol length #2,guard bar status,range mode status>
Default:	Disabled
Options:	0 = Disabled 1 = Enabled

Check Output Status (Interleaved 2 of 5)

Definition:	When enabled, a check character is sent along with the symbol data for added data security.
Serial Cmd:	<K472,status,check character status, check character output status ,symbol length #1,symbol length #2,guard bar status,range mode status>
Default:	Disabled
Options:	0 = Disabled 1 = Enabled

Symbol Length #1 (Interleaved 2 of 5)

Usage:	Useful in applications where I 2/5 symbols of a specific length are required.
Definition:	The Symbol Length # 1 field is one of two fields against which the decoded symbol is compared before accepting it as valid or rejecting it.
Serial Cmd:	<K472,status,check character status,check character output,symbol length #1,symbol length #2,guard bar status,range mode status>
Default:	16
Options:	0 to 64, even only Important: If Range Mode is disabled, the length of the symbol must match either Symbol Length # 1 or Symbol Length # 2 to be considered a valid symbol. If Range Mode is enabled, Symbol Length # 1 and Symbol Length # 2 form a range into which the length of the symbol must fall to be considered valid.

Symbol Length #2 (Interleaved 2 of 5)

Usage:	Useful in applications where I 2/5 symbols of a specific length are required.
Definition:	The Symbol Length # 2 field is one of two fields against which the decoded symbol is compared before accepting it as valid or rejecting it.
Serial Cmd:	<K472,status,check character status,check character output,symbol length #1,symbol length #2,guard bar status,range mode status>
Default:	6
Options:	0 to 64, even only Important: If Range Mode is disabled, the length of the symbol must match either Symbol Length # 2 or Symbol Length # 1 to be considered a valid symbol. If Range Mode is enabled, Symbol Length # 2 and Symbol Length # 1 form a range into which the length of the symbol must fall to be considered valid.

Guard Bar Status (Interleaved 2 of 5)



NOTE!

Whenever **Guard Bar** is enabled, the presence of guard bars (also called “bearer bars”) is required for decoding to take place.

Usage:	Useful when I-2/5 multisymbols are enabled to prevent false data output. This typically occurs with highly tilted or skewed symbols.
Definition:	A guard bar is a heavy bar, at least twice the width of the wide bar, surrounding the printed I-2/5 symbol and helping to prevent false reads.
Serial Cmd:	<K472,status,check character status,check character output,symbol length #1,symbol length #2,guard bar status,range mode status>
Default:	Disabled
Options:	0 = Disabled 1 = Enabled

Range Mode Status (Interleaved 2 of 5)

Usage:	Useful in applications where 1 2/5 symbols of a specific length are required.
Definition:	<p>When Range Mode is disabled, the reader checks the value of the symbol length against the values set in Symbol Length # 1 and Symbol Length # 2. If the symbol length does not match either of the preset values, then it is rejected as invalid.</p> <p>When Range Mode is enabled, Symbol Length # 1 and Symbol Length # 2 are combined to form a range of valid symbol lengths. Any symbol length that does not fall into this range is rejected as an invalid symbol. Either of the preset symbol length values in the Symbol Length # 1 and Symbol Length # 2 fields can form the start or end of the range.</p>
Serial Cmd:	<K472,status,check character status,check character output,symbol length #1,symbol length #2,guard bar status, range mode status >
Default:	Enabled
Options:	0 = Disabled 1 = Enabled

7.10. Code 93

Usage:	Sometimes used in clinical applications.
Definition:	Code 93 is a variable-length, continuous symbology employing four element widths. Each Code 93 character has nine modules that may be either black or white. Each character contains three bars and three spaces.
Serial Cmd:	<K475,status,fixed symbol length status,symbol length>
Default:	Enabled
Options:	0 = Disabled 1 = Enabled

Fixed Symbol Length Status (Code 93)

Definition:	When disabled, the reader will accept any Code 93 symbol provided is doesn't exceed the system's maximum capabilities. When enabled, the reader will reject any Code 93 symbol that doesn't match the fixed symbol length.
Serial Cmd:	<K475,status,fixed symbol length status,symbol length>
Default:	Disabled
Options:	0 = Disabled 1 = Enabled

Symbol Length (Code 93)

Definition:	This is the symbol length value against which all Code 93 symbols will be compared.
Serial Cmd:	<K475,status,fixed symbol length status,symbol length>
Default:	10
Options:	1 to 64

7.11. Codabar

Usage:	Used in photo-finishing and library applications. Previously used in medical applications, but not typically used in newer medical applications.	
Definition:	Codabar is a 16-bit character set (0 through 9, and the characters \$, :, /, ., +, and -) with start/stop codes and at least two distinctly different bar widths.	
Serial Cmd:	<K471,status,start/stop match,start/stop output,large intercharacter gap,fixed symbol length status,symbol length,check character type,check character output>	
Default:	Disabled	
Options:	0 = Disabled	1 = Enabled

Start/Stop Match (Codabar)

Definition:	When disabled, the reader will decode Codabar symbols whether or not the start and stop characters are the same. When enabled, the reader will not decode Codabar symbols unless the start and stop characters are the same.	
Serial Cmd:	<K471,status,start/stop match,start/stop output,large intercharacter gap,fixed symbol length status,symbol length,check character type,check character output>	
Default:	Enabled	
Options:	0 = Disabled	1 = Enabled

Start/Stop Output (Codabar)

Definition:	When disabled, the start and stop characters will not be present in the data output of the decoded symbol. When enabled, the start and stop characters will be present in the data output of the decoded symbol.	
	 <p>NOTE! Because the start and stop characters are included as part of the data, the characters must be included as part of the length in a fixed length mode of operation.</p>	
Serial Cmd:	<K471,status,start/stop match,start/stop output,large intercharacter gap,fixed symbol length status,symbol length,check character type,check character output>	
Default:	Enabled	
Options:	0 = Disabled	1 = Enabled

Large intercharacter Gap (Codabar)

Definition:	When disabled, the spaces between characters, or the “intercharacter gap”, are ignored during the decode process.  NOTE! If the intercharacter space is large enough to be considered a margin, the symbol will not decode, regardless of this parameter's setting.
Serial Cmd:	<K471,status,start/stop match,start/stop output, large intercharacter gap ,fixed symbol length status,symbol length,check character type,check character output>
Default:	Disabled
Options:	0 = Disabled 1 = Enabled

Fixed Symbol Length Status (Codabar)

Definition:	When disabled, the reader will accept any Codabar symbol provided it doesn't exceed the system's maximum capabilities. When enabled, the reader will reject any Codabar symbol that doesn't match the fixed length.
Serial Cmd:	<K471,status,start/stop match,start/stop output,large intercharacter gap, fixed symbol length status ,symbol length,check character type,check character output>
Default:	Enabled
Options:	0 = Disabled 1 = Enabled

Symbol Length (Codabar)

Definition:	This is the value against which all Codabar symbol lengths will be compared.
Serial Cmd:	<K471,status,start/stop match,start/stop output,large intercharacter gap,fixed symbol length status, symbol length ,check character type,check character output>
Default:	10
Options:	1 to 64

Check Character Type (Codabar)

Definition:	<p>When disabled, the reader will not perform any character checking calculations on decoded Codabar symbols.</p> <p>When set to Mod 16, the reader will perform a modulus 16 check character calculation on the symbol. If the symbol does not pass this calculation, it will not be decoded.</p> <p>When set to NW7, The reader will perform an NW7 modulus 11 check character calculation on the symbol. If the symbol does not pass this calculation, it will not be decoded.</p> <p>When set to Both, the reader will perform both the Mod 16 and NW7 modulus 11 check character calculations on the symbol. If the symbol does not pass either calculation, it will not be decoded.</p>
Serial Cmd:	<K471,status,start/stop match,start/stop output,large intercharacter gap,fixed symbol length status,symbol length, check character type ,check character output>
Default:	Disabled
Options:	0 = Disabled 1 = Mod 16 2 = NW7 (Mod 11) 3 = Mod 16 and NW7



Check Character Output (Codabar)

Definition:	<p>When this field is disabled and a check character calculation is enabled, the reader will strip the verified check character from the symbol data out- put. This condition must be accounted for if a fixed length is also being used.</p> <p>When enabled, the reader will output the check character as part of the symbol data. This condition must be accounted for if a fixed length is also being used.</p>
Serial Cmd:	<K471,status,start/stop match,start/stop output,large intercharacter gap,fixed symbol length status,symbol length,check character type, check character output >
Default:	Disabled
Options:	0 = Disabled 1 = Enabled

7.12. UPC/EAN

Usage:	Used primarily in point-of-sale applications in the retail industry. It is commonly used with the readers in applications in combination with Matchcode when there is a need to verify that the right product is being placed in the right packaging.
Definition:	UPC (Universal Product Code) is a fixed length, numeric, continuous symbology. UPC can have two- or five-digit supplemental bar code data following the normal code. The UPC Version A (UPC, A) symbol is used to encode a 12 digit number. The first digit is the number system character, the next five are the manufacturer number, the next five are the product number, and the last digit is the checksum character. When enabled, the reader will read UPC Version A and UPC Version E only.
Serial Cmd:	< K473 , UPC status ,EAN status,supplementals status,separator status, separator character,supplemental type,format UPC-E as UPC-A>
Default:	Enabled
Options:	0 = Disabled 1 = Enabled

EAN Status

Usage:	EAN is the European version of the UPC symbology and is used in European market applications.  NOTE! UPC must be enabled for EAN to take effect.
Definition:	EAN is a subset of UPC. When enabled, the reader will read UPC Version A, UPC Version E, EAN 13, and EAN 8. It also appends a leading zero to UPC Version A symbol information and transmits 13 digits. If transmitting 13 digits when reading UPC Version A symbols is not desired, disable EAN.  NOTE! The extra character identifies the country of origin.
Serial Cmd:	< K473 ,UPC status, EAN status ,supplementals status,separator status, separator character,supplemental type,format UPC-E as UPC-A>
Default:	Enabled
Options:	0 = Disabled 1 = Enabled

Supplemental Status (UPC/EAN)

Usage:	Reads Supplementals typically used in publications and documentation.		
Definition:	A supplemental is a 2 to 5 digit symbol appended to the main symbol. When set to Enabled or Required , the reader reads supplemental code data that has been appended to the standard UPC or EAN codes.		
Serial Cmd:	<K473,UPC status,EAN status, supplementals status ,separator status, separator character,supplemental type,format UPC-E as UPC-A>		
Default:	Enabled		
Options:	0 = Disabled	1 = Enabled	2 = Required

Disabled

UPC **Supplementals** will not be decoded.

Enabled

When enabled, the reader will try to decode a main and a supplemental.

Required

When set to **Required**, both the main and the supplemental symbols must be read.

For example, if **Supplementals** is set to **Required**, **Separator** is enabled, and an asterisk is defined as the UPC separator character. Then the data is displayed as:

MAIN * SUPPLEMENTAL.



NOTE!

Under no circumstances will the supplemental symbol data be sent without a main symbol.



NOTE!

If additional symbols—other than the main or supplemental—will be read in the same read cycle, **Number of Symbols** should be set accordingly.

Separator Status (UPC/EAN)

Usage:	Allows users to distinguish between the main and Supplemental symbols.
Definition:	A character can be inserted between the standard UPC or EAN symbology and the supplemental symbology when Supplementals is set to Enabled or Required .
Serial Cmd:	<K473,UPC status,EAN status,supplementals status, separator status , separator character,supplemental type,format UPC-E as UPC-A>
Default:	Disabled
Options:	0 = Disabled 1 = Enabled

Separator Character (UPC/EAN)

Usage:	As required by the application.
Definition:	Allows the user to change the separator character from a comma to a new character.
Serial Cmd:	<K473,UPC status,EAN status,supplementals status,separator status, separator character ,supplemental type,format UPC-E as UPC-A>
Default:	, (comma)
Options:	Any ASCII character.

NOTE!



Whenever Separator Character is defined as a comma (,) sending a <K473,s?> command will return the current settings, including the separator character comma which appears after the separator status comma.

Supplemental Type (UPC/EAN)

Usage:	As required by symbology used in application.
Definition:	Allows the user to select 2 character or 5 character supplements, or both.
Serial Cmd:	<K473,UPC status,EAN status,supplementals status,separator status, separator character, supplemental type ,format UPC-E as UPC-A>
Default:	Both
Options:	0 = Both 1 = 2 characters only 2 = 5 characters only

Both

Either 2 character or 5 character supplementals will be considered valid.

2 Characters Only

Only two character supplementals will be considered valid.

5 Characters Only

Only five character supplementals will be considered valid.

Format UPC-E as UPC-A (UPC/EAN)

Definition:	When disabled, the reader will output the version E symbols in their encoded 6-character format. When enabled, the reader will format the symbol as either a 12-character UPC-A symbol or an EAN-13 symbol, depending on the state of the EAN status parameter. This formatting reverses the zero suppression that is used to generate the symbol in the UPC specification.
Serial Cmd:	<K473,UPC status,EAN status,supplementals status,separator status, separator character,supplemental type, format UPC-E as UPC-A >
Default:	Enabled
Options:	0 = Disabled 1 = Enabled

7.13. Pharmacode

Usage:	Used mostly with packaging for the pharmaceuticals industry.
Definition:	Encodes up to five different numbers, each with its own color, which may be entered in decimal or “binary” format with a 1 represented by a thick bar and a 0 represented by a thin bar. Bar width is independent of height. In decimal format, each part can be up to 999,999. In binary format, each input can have up to 19 ones and zeros. Important: When Pharmacode is enabled, other linear symbologies will not decode properly. Disable Pharmacode before reading other linear symbologies.
Serial Cmd:	<K477,status,fixed symbol length status,fixed symbol length,minimum number of bars,bar width status,direction,fixed threshold value,background color>
Default:	Disabled
Options:	0 = Disabled 1 = Enabled

Fixed Symbol Length Status (Pharmacode)

Definition:	When enabled, the reader will check the symbol length against the symbol length field. If disabled, any length will be considered valid.
Serial Cmd:	<K477,status,fixed symbol length status,fixed symbol length,minimum number of bars,bar width status,direction,fixed threshold value,background color>
Default:	Disabled
Options:	0 = Disabled 1 = Enabled

Fixed Symbol Length (Pharmacode)

Definition:	Specifies the exact number of bars that must be present for the reader to recognize and decode the Pharmacode symbol.
Serial Cmd:	<K477,status,fixed symbol length status,fixed symbol length,minimum number of bars,bar width status,direction,fixed threshold value,background color>
Default:	5
Options:	1 to 16

Minimum Number of Bars (Pharmacode)

Definition:	Sets the minimum number of bars that a Pharmacode symbol must have to be considered valid.
Serial Cmd:	<K477,status,fixed symbol length status,fixed symbol length,minimum number of bars,bar width status,direction,fixed threshold value,background color>
Default:	4
Options:	1 to 16

Bar Width Status (Pharmacode)

Definition:	If set to Mixed , the reader will autodiscriminate between narrow bars and wide bars. If set to All Narrow , all bars will be considered as narrow bars. If set to All Wide , all bars will be considered as wide bars. If set to Fixed Threshold , it will use the fixed threshold value to determine whether the bars are narrow or wide. The Bar Width Status setting will be ignored when the reader is able to tell the difference between the narrow and the wide bars.
Serial Cmd:	<K477,status,fixed symbol length status,fixed symbol length,minimum number of bars, bar width status ,direction,fixed threshold value,background color>
Default:	Mixed
Options:	0 = Mixed 1 = All Narrow 2 = All Wide 3 = Fixed Threshold

Direction (Pharmacode)

Definition:	Specifies the direction in which a symbol can be read.
Serial Cmd:	<K477,status,fixed symbol length status,fixed symbol length,minimum number of bars, bar width status , direction ,fixed threshold value,background color>
Default:	Forward
Options:	0 = Forward 1 = Reverse

Fixed Threshold Value ((Pharmacode)

Definition:	Used when Bar Width Status is set to Fixed Threshold . Defines the minimum difference in pixels that will distinguish a narrow bar from a wide bar.
Serial Cmd:	<K477,status,fixed symbol length status,fixed symbol length,minimum number of bars, bar width status ,direction, fixed threshold value ,background color>
Default:	10
Options:	1 to 65535

Background Color (Pharmacode)

Definition:	Used when the color of bars is reversed. Sets the background color that a Pharmacode symbol must have to be considered valid.
Serial Cmd:	<K477,status,fixed symbol length status,fixed symbol length,minimum number of bars, bar width status ,direction,fixed threshold value,background color>
Default:	White
Options:	0 = Black 1 = White

7.14. Postal Symbologies

Important: Postal Symbologies must have a minimum pixels-per-element value of **4** to be decoded reliably by the reader.

The reader must be configured to specific read range, field of view, and camera parameters before decoding Postal Symbologies.

For optimal decode results, position the symbol as close to the center of the reader's field of view as possible.

Postal Symbology Type

Usage:	The following 1D Postal Symbologies are used in mail sortation, auditing, certified mail, registered mail, metered mail, and point-of-sale (POS) applications.
Definition:	Determines the postal symbology that will be decoded by the reader.
Serial Cmd:	<K460,postal symbology type,POSTNET status,PLANET status,USPS4CB status>
Default:	Disabled
Options:	0 = Disabled 1 = U.S. Post (POSTNET, PLANET, USPS4CB) 2 = Australia Post 3 = Japan Post 4 = Royal Mail 5 = KIX G 6 = UPU

U.S. Post (POSTNET, PLANET, USPS4CB)

When **U.S. Post** is enabled (<K460,1>), the reader will only decode **POSTNET**, **PLANET**, and **USPS4CB** symbols.

Important: POSTNET Status, PLANET Status, and USPS4CB Status are enabled by default. However, if any of the three U.S. Post symbologies is set to **disabled** individually, symbols of that type will not be decoded by the reader even when U.S. Post is enabled.

For example, if **U.S. Post** is enabled but **POSTNET Status** is disabled (<K460,1,0>), **POSTNET** symbols will not be decoded by the reader.

See **POSTNET Status, PLANET Status, and GS1 DataBar** for more detail about U.S. Post symbologies.

Australian Post

When **Australia Post** is enabled (<K460,2>), the reader will only decode Australia Post symbols.

Japan Post

When **Japan Post** is enabled (<K460,3>), the reader will only decode Japan Post symbols.

Royal Mail

When **Royal Mail** is enabled (<K460,4>), the reader will only decode Royal Mail symbols.

KIX
 When **KIX** is enabled (<**K460,5**>), the reader will only decode KIX symbols.

UPU
 When **UPU** is enabled, the reader will decode UPU symbols.
 For example, if **Postal Symbology Type** is set to UPU and **POSTNET Status** is enabled and (<**K460,6,1**>), the reader will attempt to decode both UPU and POSTNET symbols.

POSTNET Status

Usage:	POSTNET is used by the United States Postal Service to direct mail. The ZIP Code or ZIP+4 Code is encoded in the symbol. Data is encoded in half-height and full-height bars, making POSTNET a “2-state” symbology. The delivery point (usually the last two digits of the address or post office box number) is also typically encoded in POSTNET symbols.
Definition:	If U.S. Post and POSTNET Status are both enabled, the reader will decode POSTNET symbols.
Serial Cmd:	< K460 ,postal symbology type, POSTNET status ,PLANET status, USPS4CB status>
Default:	Enabled
Options:	0 = Disabled 1 = Enabled

PLANET Status

Usage:	PLANET (Postal Alphanumeric Encoding Technique) is a symbology used by the United States Postal Service to track and identify items during delivery. Each PLANET symbol is either 12 or 14 digits long, and encodes data in half-height and full-height bars, making PLANET a “2-state” symbology. The symbol always starts and ends with a full-height bar, or “guard rail”, and each individual digit is represented by a set of five bars in which two of the bars are always short.
Definition:	If U.S. Post and PLANET Status are both enabled, the reader will decode PLANET symbols.
Serial Cmd:	< K460 ,postal symbology type,POSTNET status, PLANET status , USPS4CB status>
Default:	Enabled
Options:	0 = Disabled 1 = Enabled

USPS4CB Status

Usage:	<p>USPS4CB, also called Intelligent Mail, is used by the United States Postal Service to sort and track individual items as well as flats of mail. USPS4CB combines the capabilities of POSTNET and PLANET, and can encode 31 digits (65 bars). USPS4CB symbols are slightly longer than POSTNET symbols, and offer additional flexibility in choosing symbol height and width.</p> <p>Data is encoded in four types of bars (“states”), each of which is identified by a name and a value. This type of postal symbol is known as “4-state”. Each bar has a “tracker”, or middle section, to which an “ascender” (top section) or “descender” (bottom section) may be added. The 4-state format allows the symbol to contain more information, and makes it easier to decode. 4-state symbols can also be printed easily in a variety of media, including dot matrix, inkjet, and laser.</p>
Definition:	If U.S. Post and USPS4CB Status are both enabled, the reader will decode USPS4CB symbols.
Serial Cmd:	< K460 ,postal symbology type,POSTNET status,PLANET status, USPS4CB status >
Default:	Enabled
Options:	0 = Disabled 1 = Enabled

7.15. GS1 DataBar

DataBar Expanded

Usage:	Used to encode primary and supplementary data in retail point-of-sale and other applications.
Definition:	DataBar Expanded is a variable length symbology that can encode supplementary information in addition to the 14-digit EAN item identification number and is capable of encoding up to 74 numeric or 41 alphabetic characters.
Serial Cmd:	<K484,status,fixed symbol length status,fixed symbol length>
Default:	Enabled
Options:	0 = Disabled 1 = Enabled

Fixed Symbol Length Status (DataBar Expanded)

Definition:	When enabled, the reader will check the symbol length against the symbol length field, minus the embedded check character. If disabled, any length would be considered valid.
Serial Cmd:	<K484,status,fixed symbol length status,fixed symbol length>
Default:	Disabled
Options:	0 = Disabled 1 = Enabled

Fixed Symbol Length (DataBar Expanded)

Usage:	Fixed Symbol Length helps prevent truncations and increases data integrity by ensuring that only one symbol length will be accepted.
Definition:	Specifies the exact number of characters that the reader will recognize (this does not include start, stop, and check character characters). The reader ignores any symbol not having the specified length.
Serial Cmd:	<K484,status,fixed symbol length status,fixed symbol length>
Default:	14
Options:	1 to 74

DataBar Limited

Usage:	DataBar Limited is designed to be read by laser and CCD readers. It is not recommended for omnidirectional slot scanners.
Definition:	Encodes a smaller 14-digit symbol (74 modules wide) that is not omnidirectional.
Serial Cmd:	<K483,status>
Default:	Enabled
Options:	0 = Disabled 1 = Enabled

DataBar-14

Usage:	Used in the grocery, retail, and prescription drug industries where 14-digit EAN item identification may be needed.
Definition:	DataBar-14 is a fixed symbol length symbology that encodes 14 digits, including a 1-digit indicator. DataBar-14 is 96 modules wide. It can be stacked in two rows, it can read omnidirectionally if printed in full height, or horizontally if height-truncated for small marking.
Serial Cmd:	<K482,status>
Default:	Enabled
Options:	0 = Disabled 1 = Enabled

7.16. PDF417

Usage:	Used in applications where a large amount of information (over 32 characters) needs to be encoded within a symbol, typically where the symbol is transported from one facility to another. For example, an automobile assembly line might use a single symbol with multiple fields of information that will be read at several stations along the way, without reference to a database.
Definition:	A two-dimensional, multi-row (3 to 90), continuous, variable length symbology that has high data capacity for storing up to 2,700 numeric characters, 1,800 printable ASCII characters, or 1,100 binary characters per symbol. Each symbol character consists of 4 bars and 4 spaces in a 17-module structure.
Serial Cmd:	< K476,status ,[unused],fixed symbol length status,fixed symbol length>
Default:	Enabled
Options:	0 = Disabled 1 = Enabled

NOTE!



Sending <a1> will cause PDF417 data to be prefaced with information consisting of error correction level (ECC Level **n**), number of rows (**n** Rows), number of columns (**n** Columns), number of informative code words (**n** Info Code Words) and the number of data characters (**n** Data Characters). This feature can be disabled by re-sending <a1>.

Fixed Symbol Length Status (PDF417)

Serial Cmd:	< K476,status ,[unused],fixed symbol length status,fixed symbol length>
Default:	Disabled
Options:	0 = Disabled 1 = Enabled

Fixed Symbol Length (PDF417)

Usage:	Used to increase data integrity by ensuring that only one symbol length will be accepted.
Definition:	When enabled, the PDF symbol must contain the same number of characters as the symbol length setting before it can be considered a good read. The reader will ignore any symbol not having the specified length.
Serial Cmd:	< K476,status ,[unused],fixed symbol length status,fixed symbol length>
Default:	10
Options:	1 to 2710

NOTE!



Fixed Symbol Length Status must be enabled for **Fixed Symbol Length** to take effect.

7.17. MicroPDF417

Usage:	Used for labelling small items that need large data capacity.
Definition:	A variant of PDF417, a very efficient and compact stacked symbology that can encode up to 250 alphanumeric characters or 366 numeric characters per symbol.
Serial Cmd:	<K485,status,[unused],fixed symbol length status,fixed symbol length>
Default:	Enabled
Options:	0 = Disabled 1 = Enabled

Fixed Symbol Length Status (MicroPDF417)

Serial Cmd:	<K485,status,[unused],fixed symbol length status,fixed symbol length>
Default:	Disabled
Options:	0 = Disabled 1 = Enabled

Fixed Symbol Length (MicroPDF417)

Usage:	Used to increase data integrity by ensuring that only one symbol length will be accepted.
Definition:	When enabled, the MicroPDF417 symbol must contain the same number of characters as the symbol length setting before it can be considered a good read. The reader will ignore any symbol not having the specified length.
Serial Cmd:	<K485,status,[unused],fixed symbol length status,fixed symbol length>
Default:	10
Options:	1 to 366



NOTE!

Fixed Symbol Length Status must be enabled for **Fixed Symbol Length** to take effect.

7.18. Composite

When set to **Enabled** or **Required**, will decode the 2D composite component of a linear symbol. The linear symbol can be DataBar-14, DataBar Expanded, DataBar Limited, EAN-128, UPC-A, EAN-13, EAN-8, and UPC-E.

Usage:	Allows reading by both linear and 2D readers.
Definition:	Combines 2D and linear width-modulated symbology on the same symbol where different messages can be read by each reader type.
Serial Cmd:	<K453,mode,separator status,separator>
Default:	Disabled
Options:	0 = Disabled 1 = Enabled 2 = Required

Enabled

If **Composite** is set to **Enabled**, the reader will decode both the 2D composite and linear components. However, if the 2D composite component is not decoded, the linear data will be sent by itself at the end of the read cycle.

Required

If set to **Required**, the reader must decode both components, or a No-Read will occur.

Separator Status (Composite)

Usage:	Allows the user to distinguish between the main and Supplemental symbols.
Definition:	Separates the linear and the composite component.
Serial Cmd:	<K453,mode,separator status,separator>
Default:	Disabled
Options:	0 = Disabled 1 = Enabled

Separator Character (Composite)



NOTE!

The Separator Character will be the same as the character defined in the **Multisymbol Separator** field of the <K222> command.

Usage:	As required by the application.
Definition:	Allows the user to change the separator character from a comma to a new character.
Serial Cmd:	<K453,mode,separator status,separator>
Default:	, (comma)
Options:	Any ASCII character.

7.19. DotCode

Important: When DotCode is enabled, no other symbologies will be decodable. You must disable DotCode to decode symbols of any other type.

DotCode Status

Serial Cmd:	<K497,status,rotation mode>
Default:	Disabled
Options:	0 = Disabled 1 = Enabled

Disabled

The reader will not attempt to decode DotCode symbols.

Enabled

The reader will attempt to decode DotCode symbols.

Rotation Mode

Serial Cmd:	<K497,status,rotation mode>
Default:	0 = No Rotation
Options:	0 = No Rotation 1 = Low Rotation 2 = Omnidirectional

No Rotation

The reader will decode horizontal and vertical symbols (+/- approximately **3 degrees**).

Low Rotation

The reader will decode +/- approximately **10 degrees** from the horizontal or vertical symbols. It is slightly slower than the No Rotation option.

Omnidirectional

The reader supports **360 degree** decoding. It is significantly slower than the other two options.

8. I/O Parameters

This section includes instructions on setting up conditions for changing input/output electrical transitions for control of the reader's internal and external devices. A discrete I/O (in/out) signal is an electrical transition from one voltage level to another so that digital switching can occur.

I/O Parameters Serial Commands	119
Symbol Data Output	121
No-Read Message	124
Read Duration Output	125
Output Indicators	126
LED Configuration	128
Serial Verification	129
Setup button	130
Setup Button Modes	132
Configurable Output 1	134
Trend Analysis Output 1	137
ISO/IEC 16022 Symbol Quality Output 1	139
ISO/IEC 15415 Symbol Quality Output 1	142
ISO/IEC 15416 Symbol Quality Output 1	148
ISO/IEC 29158 Symbol Quality Output 1	155
Diagnostics Output 1	160
Other Outputs	161
Power On/Reset Counts	164
Time Since Reset	164
Service Message	165
User-Assigned Name	165
Output Object Info	166
Database Identifier Output	167
Quality Output	168
Image Push to Host	168
Image Push to Host Detailed Setup	170

8.1. I/O Parameters Serial Commands

Power On/Reset Counts	<K406,power-on,resets,power-on saves,customer default saves>
Time Since Reset (Read-Only)	<K407,hours,minutes>
Service Message	<K409,status,service message,threshold,resolution>
User-Defined Name	<K412,user-defined name>
Serial Verification	<K701,serial command echo status,control/hex output>
Quality Output	<K704,quality output separator,decodes per trigger status>
Symbol Data Output	<K705,status,when to output,symbology identifier status>
Read Duration Output	<K706,status,separator>
No-Read Message	<K714,status,message>
Output Object Info	<K734,output frame number status,output coordinates status>
LED Configuration	<K737,ISO/IEC 16022 grade>
Output Indicators	<K750,green flash LED status,target pattern LED status,green flash duration>
Database Identifier Output	<K759,status,separator character>
Image Push to Host	<K764,Image Storage Status,Stored Image Type,Image Storage, Image File Format,Image Quality,Image Scale,File Save Options>
Image Push to Host Detail Setup	<K763,Image Storage Location,FTP Host Info,Transfer Optimization, RAM Drive Size in MB,Save Image Until,Action at Image Storage Limit>
Setup Button	<K770,global status,default on power-on,load configuration database, save for power-on>
Setup Button Modes	<K771,button option 1,button option 2,button option 3,button option 4>
Trend Analysis Output 1	<K780,trend analysis mode,number of triggers,number to output on,decodes per trigger>
Trend Analysis Output 2	<K781,trend analysis mode,number of triggers,number to output on,decodes per trigger>
Trend Analysis Output 3	<K782,trend analysis mode,number of triggers,number to output on,decodes per trigger>
Diagnostic Output 1	<K790,service unit message status>
Diagnostic Output 2	<K791,service unit message status>
Diagnostic Output 3	<K792,service unit message status>
ISO/IEC 16022 Symbol Quality Output 1	<K800,output on symbol contrast,symbol contrast threshold,output on print growth,print growth threshold,output on axial non-uniformity, axial non-uniformity threshold,output on Unused ECC,Unused ECC threshold>
ISO/IEC 16022 Symbol Quality Output 2	<K801,output on symbol contrast,symbol contrast threshold,output on print growth,print growth threshold,output on axial non-uniformity, axial non-uniformity threshold,output on Unused ECC,Unused ECC threshold>
ISO/IEC 16022 Symbol Quality Output 3	<K802,output on symbol contrast,symbol contrast threshold,output on print growth,print growth threshold,output on axial non-uniformity, axial non-uniformity threshold,output on Unused ECC,Unused ECC threshold>
Output 1 Parameters	<K810,output on,output state,pulse width,output mode>
Output 2 Parameters	<K811,output on,output state,pulse width,output mode>
Output 3 Parameters	<K812,output on,output state,pulse width,output mode>

ISO/IEC 15415 Symbol Quality Output 1	< K870 , Output on Overall Grade, Overall Grade Threshold, Symbol Contrast, Symbol Contrast Threshold, Modulation, Modulation Threshold, Reflectance Margin, Reflectance Margin Threshold, Fixed Pattern Damage, Fixed Pattern Damage Threshold, Axial Nonuniformity, Axial Nonuniformity Threshold, Grid Nonuniformity, Grid Nonuniformity Threshold, Unused ECC, Unused ECC Threshold>
ISO/IEC 15415 Symbol Quality Output 2	< K871 , Output on Overall Grade, Overall Grade Threshold, Symbol Contrast, Symbol Contrast Threshold, Modulation, Modulation Threshold, Reflectance Margin, Reflectance Margin Threshold, Fixed Pattern Damage, Fixed Pattern Damage Threshold, Axial Nonuniformity, Axial Nonuniformity Threshold, Grid Nonuniformity, Grid Nonuniformity Threshold, Unused ECC, Unused ECC Threshold>
ISO/IEC 15415 Symbol Quality Output 3	< K872 , Output on Overall Grade, Overall Grade Threshold, Symbol Contrast, Symbol Contrast Threshold, Modulation, Modulation Threshold, Reflectance Margin, Reflectance Margin Threshold, Fixed Pattern Damage, Fixed Pattern Damage Threshold, Axial Nonuniformity, Axial Nonuniformity Threshold, Grid Nonuniformity, Grid Nonuniformity Threshold, Unused ECC, Unused ECC Threshold>
ISO/IEC 15416 Symbol Quality Output 1	< K880 , Output on Overall Grade, Overall Grade Threshold, Edge Determination, Edge Determination Threshold, Decode, Decode Threshold, Contrast, Contrast Threshold, Min Reflectance, Min Reflectance Threshold, Min Edge Contrast, Min Edge Contrast Threshold, Modulation, Modulation Threshold, Defects, Defects Threshold, Decodability, Decodability Threshold, Quiet Zone, Quiet Zone Threshold >
ISO/IEC 15416 Symbol Quality Output 2	< K881 , Output on Overall Grade, Overall Grade Threshold, Edge Determination, Edge Determination Threshold, Decode, Decode Threshold, Contrast, Contrast Threshold, Min Reflectance, Min Reflectance Threshold, Min Edge Contrast, Min Edge Contrast Threshold, Modulation, Modulation Threshold, Defects, Defects Threshold, Decodability, Decodability Threshold, Quiet Zone, Quiet Zone Threshold >
ISO/IEC 15416 Symbol Quality Output 3	< K882 , Output on Overall Grade, Overall Grade Threshold, Edge Determination, Edge Determination Threshold, Decode, Decode Threshold, Contrast, Contrast Threshold, Min Reflectance, Min Reflectance Threshold, Min Edge Contrast, Min Edge Contrast Threshold, Modulation, Modulation Threshold, Defects, Defects Threshold, Decodability, Decodability Threshold, Quiet Zone, Quiet Zone Threshold >
ISO/IEC 29158 Symbol Quality Output 1	< K890 , Output on Overall Grade, Overall Grade Threshold, Cell Contrast, Cell Contrast Threshold, Cell Modulation, Cell Modulation Threshold, Fixed Pattern Damage, Fixed Pattern Damage Threshold, Axial Nonuniformity, Axial Nonuniformity Threshold, Grid Nonuniformity, Grid Nonuniformity Threshold, Unused ECC, Unused ECC Threshold>
ISO/IEC 29158 Symbol Quality Output 2	< K891 , Output on Overall Grade, Overall Grade Threshold, Cell Contrast, Cell Contrast Threshold, Cell Modulation, Cell Modulation Threshold, Fixed Pattern Damage, Fixed Pattern Damage Threshold, Axial Nonuniformity, Axial Nonuniformity Threshold, Grid Nonuniformity, Grid Nonuniformity Threshold, Unused ECC, Unused ECC Threshold>
ISO/IEC 29158 Symbol Quality Output 3	< K892 , Output on Overall Grade, Overall Grade Threshold, Cell Contrast, Cell Contrast Threshold, Cell Modulation, Cell Modulation Threshold, Fixed Pattern Damage, Fixed Pattern Damage Threshold, Axial Nonuniformity, Axial Nonuniformity Threshold, Grid Nonuniformity, Grid Nonuniformity Threshold, Unused ECC, Unused ECC Threshold>

8.2. Symbol Data Output

Symbol Data Output Status



NOTE!

Symbol Data Output relates to data and should not be confused with **Outputs 1, 2, and 3** listed in the **Output Parameters** which describe output states and functions.

Usage:	Useful when the host needs symbol data only under certain conditions.
Definition:	Defines the conditions under which decoded symbol data is transmitted to the host.
Serial Cmd:	<K705,symbol data output status,when to output,symbology identifier status>
Default:	Good Read
Options:	0 = Disabled 1 = Match 2 = Mismatch 3 = Any Good Read 4 = Only If All Good Reads



NOTE!

Symbol Data Output Status, if set to **Match** or **Mismatch**, will not take effect unless **Matchcode Type** is enabled and a master symbol is loaded into memory.

Disabled

Usage:	It is useful when an application only needs to use the discrete outputs and can allow the reader to do the decision-making. When Disabled, the host does not need the symbol data and the communication lines are used only for setup and status checks.
Definition:	When set to Disabled, the reader will not transmit any data that is generated during a read cycle (symbols, No-Reads, etc.)

Match

Usage:	Match is used in an application that requires specific symbol information and needs to sort, route, or verify based on matching the specific symbol data.
Definition:	When set to Match , the reader transmits symbol data whenever a symbol matches a master symbol. However, if Matchcode Type is Disabled , it transmits on any good read.



NOTE!

A No-Read can still be transmitted if **Enabled**.

Mismatch

Usage:	Mismatch is typically used as a flag within the host system to prevent an item from being routed in the wrong container.
Definition:	With Mismatch enabled, the reader transmits symbol data whenever the symbol data information does NOT match the master symbol.



NOTE!

A No-Read can still be transmitted if **Enabled**.

Any Good Read

Usage:	Any Good Read is used when an application requires all symbol data to be transmitted. It's typically used in tracking applications in which each object is uniquely identified.
Definition:	With Any Good Read enabled, the reader outputs symbol data for any qualified symbol in the read cycle regardless of Matchcode Type setting. No Read is output if no symbols are qualified.

Only If All Good Reads

Definition:	With Only If All Good Reads enabled, the reader outputs symbol data only when all symbols in the read cycle are qualified. No Read is output if no symbols are qualified.
--------------------	---

When to Output Symbol Data

Definition:	This command allows the user to choose when symbol data can be sent to the host.
Serial Cmd:	<K705,symbol data output status, when to output ,symbology identifier status>
Default:	As Soon As Possible
Options:	0 = ASAP 1 = End of Read Cycle

As Soon As Possible

Usage:	As Soon As Possible is useful in applications in which symbol data needs to be moved quickly to the host, typically when the host is making decisions based on symbol data.
Definition:	Enabling As Soon As Possible causes symbol data to be sent to the host immediately after a symbol has been successfully decoded.



NOTE!

More than one decode might in fact be required to qualify as a good read, depending on how **Decodes Before Output** is set.

End of Read Cycle

Usage:	End of Read Cycle is useful in timing-based systems in which the host is not ready to accept data at the time that it is decoded.
Definition:	Enabling End of Read Cycle means that symbol data does not get sent to the host until the read cycle ends with a timeout or new trigger

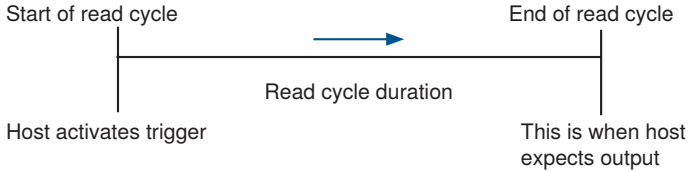

Symbology Identifier Status

Serial Cmd:	<K705,symbol data output status,when to output,symbology identifier status>
Default:	Disabled
Options:	0 = Disabled 1 = Enabled

Disabled

When set to **Disabled**, the symbol data output does not contain symbology information.

Enabled

When set to **Enabled**, the symbol data output contains a three-character symbology identifier sequence.

8.3. No-Read Message

Usage:	Used in applications where the host needs serial verification that a symbol has not been read and especially useful in new print verification.
Definition:	When enabled, and if no symbol has been decoded before timeout or the end of the read cycle, the No-Read message will be transmitted to the host.

No-Read Message Mode

Serial Cmd:	<K714,No-Read message status,No-Read message>
Default:	Enabled
Options:	0 = Disabled 1 = Enabled

Disabled

Only symbol data is output after a read cycle.

Enabled

When the reader is in a triggered mode, a No-Read message will be appended for each failed read attempt.

No-Read Message

Definition:	Any combination of ASCII characters can be defined as the No-Read message.
Serial Cmd:	<K714,No-Read message status, No-Read message >
Default:	NOREAD
Options:	A string of up to 64 characters.



NOTE!

No-Read Message will only be transmitted if **Symbol Data Output** is set to **Match, Mismatch, or Good Read**.

No-Read Message can be set to any ASCII character.

8.4. Read Duration Output

Usage:	Useful in evaluating actual read cycle timing results, especially when initially setting up an application to determine maximum line speed (obtainable based on spacing between symbols.)
Definition:	When enabled the duration of the read cycle (in milliseconds) is appended to the symbol data. The read duration is the time from the beginning of the read cycle until data is output.

Read Duration Output Mode

Serial Cmd:	<K706,status,separator>
Default:	Disabled
Options:	0 = Disabled 1 = Enabled

Important: To measure the entire read cycle when in **External Level** trigger mode, set **When to Output Symbol Data to End of Read Cycle**.

This output can measure over 49 days' worth of duration; if exceeded, the "OVERFLOW" message will be output in place of the duration.

Read Duration Output Separator

Definition:	User defined character that separates the symbol information from the Read Duration Output .
Serial Cmd:	<K706,status,separator>
Default:	[space character]
Options:	Any ASCII character.

8.5. Output Indicators

C5PC readers have three LED arrays, as follows:

1. A target pattern of blue LEDs for centering the field of view, which is projected from the front of the reader.
2. An array of green LEDs projected from the front of the reader that can be programmed to flash in response to user-defined conditions.
3. A row of five status LEDs on the side of the reader.

Green Flash Mode

Usage:	Used as a visual verification that a good read has occurred.
Definition:	An array of green LEDs in the front of the reader can be programmed to flash in response to user-defined conditions.
Serial Cmd:	<K750,green flash mode,target pattern status,green flash duration>
Default:	Static Presentation
Options:	0 = Disabled 1 = Good Read 2 = Static Presentation 3 = Match 4 = Mismatch 5 = Strobe

Disabled

Green flash LEDs are disabled.

Good Read

Green flash LEDs will flash when a good read condition is met or when Matchcode is enabled and a match occurs.

Static Presentation Mode

Static Presentation Mode is used in conjunction with **Continuous Read Mode**: <K200,0>.

When operating in **Static Presentation Mode**, the red LEDs will illuminate while the reader is searching for a symbol in **Continuous Read Mode**. When a symbol is placed in the field of view and a good read occurs, the green LEDs will illuminate and stay on for the duration of time set in **Green Flash Duration**. Only one read will occur during that time unless more than one symbol is enabled in **Number of Symbols**.

NOTE!



If **Static Presentation Mode** is selected but the reader is not in **Continuous Read**, the **Green Flash** will not occur.

To use Static Presentation:

1. Enable Continuous Read.
2. Select the number of symbols.
3. Enable Static Presentation in Green Flash Mode.
4. Select the read time in Green Flash Duration.

Match

The green LEDs will flash when a match condition is met. If multisymbol is enabled, then green flash LEDs will illuminate only if all symbols qualify as a match. If matchcode is disabled, then this mode will activate the LEDs on a good read.

Mismatch

Same as **Match**, except that LEDs will illuminate on a mismatch.

Strobe

Green flash LEDs will act as an illumination strobe for image capture. If it is required that the green flash LEDs be the only illumination for image capture, then the internal illumination LEDs can be disabled.

Target Pattern

Usage:	Assists users in positioning and locating symbols in the center of the reader's field of view.
Definition:	<K750,green flash mode,target pattern status,green flash duration>
Serial Cmd:	<K750,green flash mode, target pattern status ,green flash duration>
Default:	Always ON
Options:	0 = Always OFF 1 = ON only when not in the read cycle 2 = ON only when in the read cycle 3 = Always ON

Always OFF

The target pattern will remain OFF at all times unless overridden by an operational command.

ON Only When Not in the Read Cycle

The target pattern is always ON except during the read cycle. If the operational command overrides this setting, the target pattern will remain on at all times.

ON Only When in the Read Cycle

The target pattern will remain OFF except during the read cycle. If the operational command overrides this setting, the target pattern will remain on at all times.

Always ON

The target pattern is always ON.

Green Flash Duration

Usage:	Provides visual verification that a good read has occurred.
Definition:	When a good read occurs, the green LEDs will illuminate and stay on for the time set in the Green Flash Duration value.
Serial Cmd:	< K750 ,green flash mode,target pattern status, green flash duration >
Default:	25 (250ms)
Options:	0 to 65535 (in 10 ms increments)

8.6. LED Configuration

Usage:	Useful as a visible indicator of read rates and symbol quality.
Definition:	Determines the mode in which the status LEDs operate.
Serial Cmd:	< K737 , LED mode ,ISO/IEC 16022 grade>
Default:	Standard
Options:	0 = Standard 1 = ISO/IEC 16022 grade

In ISO/IEC 16022 grade mode the LEDs represent the grade of the first Data Matrix symbol decoded in the read cycle.

The parameter to be graded is set in the **ISO/IEC 16022 Grade** options.

For example, to program the LEDs to indicate the ISO/IEC 16022 print growth grade, set **LED Mode to ISO/IEC 16022 Grade** and set **ISO/IEC 16022 Grade to Print Growth**. If all the LEDs from 20 % to 100 % are illuminated, the read result is a grade A; if only the 20 % LED is illuminated, the result is a grade F.

Standard

In **Standard Mode**, the STATUS LED indicates read cycle status and the GOOD READ LED illuminates upon a good read at the end of a read cycle. In a read rate test, these LEDs represent the percentage of good reads per images captured.

ISO/IEC 16022 Grade

Usage:	Provides visual grading of specific ISO/IEC 16022 parameters.
Definition:	Determines which ISO/IEC 16022 parameter the reader will grade via the LEDs.
Serial Cmd:	< K737 ,LED mode, ISO/IEC 16022 grade >
Default:	Final Grade
Options:	0 = Final Grade 1 = Symbol Contrast 2 = Print Growth 3 = Axial Non-Uniformity 4 = Unused ECC

8.7. Serial Verification

Allows the user to verify configuration command status.

Serial Command Echo Status

Usage:	This command is useful in removing any doubt about the reader's interpretation of any configuration command. For example, if the current preamble is "SOM" and <K701,1, ,START> is entered, the reader will echo back <K701,SOM> since the attempted entry "START" exceeds the four character limit for that command. Therefore, it is rejected and the existing "SOM" message is echoed back and remains the preamble message.
Definition:	When enabled, a configuration command received from the host is echoed back to the host with the resultant settings. 
Function	If a command with multiple fields is processed, some of the fields may have been processed properly while others were not. The changes will appear in the string echoed back so that the user will know which fields did or did not change.
Serial Cmd:	<K701,serial command echo status, unused, control/hex output>
Default:	Disabled
Options:	0 = Disabled 1 = Enabled

Control/Hex Output

Usage:	Useful for viewing settings with binary characters when using serial commands on a terminal.
Definition:	Determines the response to a Serial Command Echo or status request command. When set to Control , two characters are transmitted to represent a non-displayable character. For example, a carriage return will be shown as: ^M.
Serial Cmd:	<K701,serial command echo status, unused, control/hex output>
Default:	Control
Options:	0 = Control 1 = Hex

8.8. Setup button

The Setup button has four positions, selectable by the length of time the button is held down. Each position can be programmed for any of eight options.

Definition:	Serves as a master switch to enable/disable the Setup button status.
Serial Cmd:	<K770,global status,default on power-on,load Configuration Database, save for power-on>
Default:	Enabled
Options:	0 = Disabled 1 = Enabled 2 = Trigger 4 = Parameter Switch

Global Status

Disabled

When set to **Disabled**, the Setup button does not function.

Enabled

When selected, the Setup button is enabled and the function of each button position is selected by the **Setup Button Mode** command.

Trigger

When selected, the Setup button acts as a trigger for the imager to start and end read cycles. All other button operations are inactive.

In External Level:	The read cycle endures for as long as the Setup button is pressed, unless a timeout occurs and Timeout is enabled for End of Read Cycle .
In External Edge:	As with Level , Edge allows a read cycle to be initiated by pressing the Setup button, but unlike Level , the read cycle ends with a good read output, a timeout, or a new trigger.

Parameter Switch

The parameter switch toggles between custom defaults and power-on settings. The condition is the same as that achieved by sending the <Arc> and <Arp> commands consecutively.

Default on Power-On

Definition:	When enabled, if the Setup button is held down on power-on the imager will default to customer defaults and save for power-on. This is the same as sending a <Zrc> command.
Serial Cmd:	<K770,global status,default on power-on,load Configuration Database, save for power-on>
Default:	Enabled
Options:	0 = Disabled 1 = Enabled

Load Configuration Database

Definition:	Allows the user to load the Configuration Database with calibration results. When the user performs a calibration using the Setup button, all the database entries are moved down one index and the results of the calibration are saved to index 1. The results will be saved as current settings as well.
Serial Cmd:	<K770,global status,default on power-on, load Configuration Database , save for power-on>
Default:	Enabled
Options:	0 = Disabled 1 = Enabled

Save for Power-On

Definition:	If enabled, after calibration is complete, all parameters will be saved for power-on.
Serial Cmd:	<K770,global status,default on power-on, load Configuration Database , save for power-on >
Default:	Disabled
Options:	0 = Disabled 1 = Enabled

8.9. Setup Button Modes

Usage:	Useful for performing multiple, repetitive tasks at the work site.			
Definition:	The global status field for the Setup button must be enabled for button processing to start. Once you press the button the reader will sequence through each button position. If you release the button after the button position but before the next button option starts, the reader will execute the action programmed for that button position. The status LEDs and the green flash will also illuminate to signal the current position. All button positions have the same configurable options. Also note that a quick press and release of the button before any button position is the same as if a position selected was configured as disabled.			
Serial Cmd:	<K771,button option 1,button option 2,button option 3,button option 4>			
Options:	Button Option 1	Button Option 2	Button Option 3	Button Option 4
	0 = Disabled	0 = Disabled	0 = Disabled	0 = Disabled
	1 = Read Rate	1 = Read Rate	1 = Read Rate	1 = Read Rate
	2 = Calibrate	2 = Calibrate	2 = Calibrate	2 = Calibrate
	3 = Save for Power-On	3 = Save for Power-On	3 = Save for Power-On	3 = Save for Power-On
	4 = Unused	4 = Unused	4 = Unused	4 = Unused
	5 = Load New Master	5 = Load New Master	5 = Load New Master	5 = Load New Master
	6 = Unused	6 = Unused	6 = Unused	6 = Unused
	7 = Target System	7 = Target System	7 = Target System	7 = Target System
	8 = Unused	8 = Unused	8 = Unused	8 = Unused
	9 = Bar Code Config.	9 = Bar Code Config.	9 = Bar Code Config.	9 = Bar Code Config.

Disabled

When set to disabled, the associated button position will have no function associated with it, and the position will be skipped over.

Read Rate

Read Rate will be initiated when the associated button position is selected. Read Rate will perform decodes/second and is the same as sending a <C> from the terminal. To exit Read Rate Mode quickly press and release the Setup button.

Calibrate

Calibration will be initiated when the associated button position is selected. To abort calibration, quickly press and release the Setup button.

Save for Power-On

All imager settings will be saved to non-volatile memory to be recalled on power-on whenever the associated button position is selected. This is the same as sending a <Z> from the terminal.

Load New Master

Functions in the same way as new master pin input whenever the associated button position is selected. The new master pin's **Consecutive Decode** requirement holds true for this function.

Target System

Turns on the target pattern whenever the associated button position is selected. To disable, quickly press and release the Setup button.



NOTE!

This mode is the only one that does not require that the button be released before taking effect. If it is necessary to have the target system on before another operation such as calibration or read rate is performed, ensure that the target system mode is assigned a lower position so that it will be activated first.

Bar code Configuration

Enables bar code configuration mode whenever the associated button position is selected. When enabled, the imager can accept configuration commands from symbols. To disable, quickly press and release the Setup button.

Setup Button Operation

To execute Setup button commands:

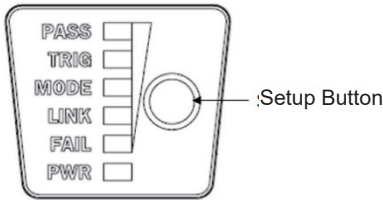

- **Position 1**

Hold down button until the 20 % LED illuminates.

- **Position 2**

Hold down button until the 20 % and 40 % LEDs illuminate.

- **Position 3**

Hold down button until the 20%, 40%, and 60% LEDs illuminate.

- **Position 4**

Hold down button until the 20%, 40%, 60%, and 80% LEDs illuminate.

8.10. Configurable Output 1

Usage:	This option provides discrete signalling to host software to control external devices such as PLCs and relays. It is useful for routing, sorting, and to prevent mis-packaging and mis-routing.
Definition:	Sets the discrete output functions for specific user-selected conditions. Allows the user to set the conditions under which an output (or outputs) will be activated.
Serial Cmd:	<K810,output on,output state,pulse width,output mode>
Default:	Mismatch or No-Read
Options:	0 = Mismatch or No-Read 1 = Match (or Good Read) 2 = Mismatch 3 = No-Read 4 = Trend Analysis 5 = Symbol Quality 6 = Diagnostic Warning 7 = In Read Cycle



NOTE!

If **Output On** is set to **Match** or **Mismatch**, a transition (switching) will not occur unless **Matchcode Type** is enabled and a master symbol is loaded into memory.

Mismatch or No-Read

Activates discrete output when the data does not match that of the master symbol or the symbol has not been decoded before the end of the read cycle.

Match (or Good Read)

Activates a discrete output when the symbol data matches the master symbol.



NOTE!

If you want to output for a good read and **Matchcode** is not enabled, you can enable any output for **Match**.

Mismatch

Activates a discrete output whenever the symbol data does not match that of the master symbol.

No-Read

Activates a discrete output whenever the symbol data is not decoded before the end of the read cycle.

Trend Analysis

Usage:	Typically used when successful decodes are occurring but a discrete output is needed to flag a trend in quality issues.
Definition:	Activates discrete output when a trend analysis condition is met, depending on the trend analysis option enabled.

Diagnostic Warning

Usage:	Typically used when a discrete indication of a diagnostic condition is needed.
Definition:	Activates discrete output when a diagnostic warning condition is met, depending on the diagnostic option enabled.

In Read Cycle

Definition:	Activates a discrete output when the reader is in a read cycle.
--------------------	---

Output State

Definition:	Sets the active electrical state of the discrete output.
Serial Cmd:	<K810,output on,output state,pulse width,output mode>
Default:	Normally Open
Options:	0 = Normally Open 1 = Normally Closed

Pulse Width

Definition:	Sets the time in 1 ms increments that the discrete output remains active.
Serial Cmd:	<K810,output on,output state,pulse width,output mode>
Default:	500 ms
Options:	0 to 65535 (in 1 ms increments)

Output Mode

Definition:	Sets the condition in which the discrete output is deactivated.
Serial Cmd:	<K810,output on,output state,pulse width,output mode>
Default:	Pulse
Options:	0 = Pulse 2 = Latch Mode 2 3 = Latch Mode 3

Pulse

This is the default mode of operation in which the programmable output is activated when the **Output On** condition has been met and held active for the duration of the selected pulse width.

Latch Mode 2 (Unlatch Opposite Condition)

The programmable output is activated when the **Output On** condition has been met and held active until the opposite condition selected under **Output On** has been met.

For example, if **No-Read** is enabled under **Output On**, the programmable output will go active on a No- Read and remain active until the opposite condition, a good read, occurs.

Latch Mode 3 (Unlatch Re-enter Read Cycle)

The programmable output is active when the Output On condition has been met and is held active until a new read cycle begins.



NOTE!

All of the **Output On** modes are inhibited when any **Output on Warning** is active for **Output 1**.

8.11. Trend Analysis Output 1

Usage:	Useful in cases where the user doesn't want to shut down for one condition but wants to monitor quality and read conditions.
Definition:	Applies Trend Analysis settings to Output 1. With Trend Analysis, the user can track the occurrences and frequency of mismatches, No-Reads, and the number of reads per trigger, and output the results to any of three outputs.
Example:	Trend Analysis Mode = No-Read Trigger Evaluation Period= 25 triggers (read cycles) Number to Output On = 4 In this example, the reader will activate an output when 4 No-Reads occur within a period of 25 triggers (read cycles).

Trend Analysis Mode

Definition:	Sets the trend condition (Mismatch, No-Read, or Decodes per Trigger) that will activate the output.
Serial Cmd:	<K780,trend analysis mode,trigger evaluation period,number to output on,decodes per trigger threshold>
Default:	No-Read
Options:	0 = Mismatch 1 = No-Read 2 = Decodes per Trigger

Mismatch

Output will be activated when the number of mismatches equals the value entered for **Number to Output On** within the trigger window selected in **Number of Triggers**.

No-Read

Output will be activated when the number of No-Reads equals the value entered for **Number to Output On** within the trigger window selected in **Number of Triggers**.

Decodes per Trigger

Output will be activated when the number of decodes equals the value entered for **Number to Output On** within the trigger window selected in **Number of Triggers**.

Trigger Evaluation Period

Definition:	The number of triggers to examine for the trend analysis condition.
Serial Cmd:	<K780,trend analysis mode,trigger evaluation period,number to output on,decodes per trigger threshold>
Default:	0
Options:	0 to 255

Number to Output On

Usage:	Example: If Number to Output On is set to 3 and Trend Analysis Mode is set to No-Read , then the output will not be activated until 3 No-Reads have occurred.
Definition:	Sets the number of Trend Analysis Mode events (mismatches, No-Reads, or reads/trigger as configured by Trend Analysis Mode) to occur within the trigger evaluation period before activating the associated output.
Serial Cmd:	<K780,trend analysis mode,trigger evaluation period,number to output on,decodes per trigger threshold>
Default:	0
Options:	0 to 255

Decodes per Trigger Threshold

Definition:	<p>The appropriate output will be activated if, at the end of the read cycle, the symbol decode count is below this setting.</p> <p>NOTE! To activate this feature the reader must be in Decodes per Trigger mode. To put the reader in this mode during the read cycle and the Trend Analysis operation, the Decodes per Trigger status in the quality settings must be enabled. Enabling this setting will also append the decode count to the symbol data.</p> 
Serial Cmd:	<K780,trend analysis mode,trigger evaluation period,number to output on, decodes per trigger threshold >
Default:	0
Options:	0 to 65535

8.12. ISO/IEC 16022 Symbol Quality Output 1

• Output on Symbol Contrast

Usage:	Lets the user know if symbol quality is less than acceptable. Definition: If enabled, toggles Output 1 to an active state when Symbol Contrast Threshold is met.
Serial Cmd:	<K800,output on symbol contrast,symbol contrast threshold,output on print growth,print growth threshold,output on axial non-uniformity,axial non-uniformity threshold,output on UEC,UEC threshold>
Default:	Disabled
Options:	0 = Disabled 1 = Enabled

• Output on Print Growth

Usage:	Lets the user know if symbol quality is less than acceptable.
Definition:	If enabled, toggles Output 1 to an active state when Print Growth Threshold is met.
Serial Cmd:	<K800,output on symbol contrast,symbol contrast threshold, output on print growth ,print growth threshold,output on axial non-uniformity,axial non-uniformity threshold,output on UEC,UEC threshold>
Default:	Disabled
Options:	0 = Disabled 1 = Enabled

• Output on Axial Non-Uniformity

Usage:	Lets the user know if symbol quality is less than acceptable.
Definition:	If enabled, toggles Output 1 to an active state when Axial Non-Uniformity Threshold is met.
Serial Cmd:	<K800,output on symbol contrast,symbol contrast threshold,output on print growth,print growth threshold,output on axial non-uniformity,axial non-uniformity threshold, output on UEC ,UEC threshold>
Default:	Disabled
Options:	0 = Disabled 1 = Enabled

• **Output on Unused Error Correction**

Usage:	Lets the user know if symbol quality is less than acceptable.
Definition:	If enabled, toggles Output 1 to an active state when UEC Threshold is met.
Serial Cmd:	< K800 ,output on symbol contrast,symbol contrast threshold,output on print growth,print growth threshold,output on axial non-uniformity,axial non-uniformity threshold, output on UEC ,UEC threshold>
Default:	Disabled
Options:	0 = Disabled 1 = Enabled

• **Symbol Contrast Threshold**

Usage:	Lets the user set the acceptable level of symbol quality. Definition: Conforms to ISO/IEC 16022 symbol quality grading (A,B,C,D).
Serial Cmd:	< K800 ,output on symbol contrast, symbol contrast threshold ,output on print growth,print growth threshold,output on axial non-uniformity,axial non-uniformity threshold,output on UEC,UEC threshold>
Default:	Grade C
Options:	0 = Grade A 1 = Grade B 2 = Grade C 3 = Grade D

• **Print Growth Threshold**

Usage:	Lets the user set the acceptable level of symbol quality.
Definition:	Conforms to ISO/IEC 16022 symbol quality grading (A,B,C,D).
Serial Cmd:	< K800 ,output on symbol contrast,symbol contrast threshold,output on print growth,print growth threshold,output on axial non-uniformity,axial non-uniformity threshold,output on UEC,UEC threshold>
Default:	Grade C
Options:	0 = Grade A 1 = Grade B 2 = Grade C 3 = Grade D

• **Axial Non-Uniformity Threshold**

Usage:	Lets the user set the acceptable level of symbol quality.
Definition:	Conforms to ISO/IEC 16022 symbol quality grading (A,B,C,D).
Serial Cmd:	< K800 ,output on symbol contrast,symbol contrast threshold,output on print growth,print growth threshold,output on axial non-uniformity,axial non-uniformity threshold,output on UEC,UEC threshold>
Default:	Grade C
Options:	0 = Grade A 1 = Grade B 2 = Grade C 3 = Grade D

• **Unused Error Correction Threshold**

Usage:	Lets the user set the acceptable level of symbol quality.
Definition:	Conforms to ISO/IEC 16022 symbol quality grading (A,B,C,D).
Serial Cmd:	< K800 ,output on symbol contrast,symbol contrast threshold,output on print growth,print growth threshold,output on axial non-uniformity,axial non-uniformity threshold,output on UEC, UEC threshold >
Default:	Grade C
Options:	0 = Grade A 1 = Grade B 2 = Grade C 3 = Grade D

8.13. ISO/IEC 15415 Symbol Quality Output 1

Barcode Symbol Print Quality Test Specification – 2D Symbols

Supported symbologies:

- Data Matrix ECC200
- QR Code
- Micro QR Code

Minimum Resolution: 6.0 Pixels Per Element

• Output on Overall Grade

Usage:	Lets the user know if symbol quality is less than acceptable.
Definition:	If enabled, drives Output if grade is under Overall Grade Threshold .
Serial Cmd:	< K870 , output on overall grade , overall grade threshold, symbol contrast, symbol contrast threshold, modulation, modulation threshold, reflectance margin, reflectance margin threshold, fixed pattern damage, fixed pattern damage threshold, axial non-uniformity, axial non-uniformity threshold, grid non-uniformity, grid non-uniformity threshold, unused ECC, unused ECC threshold>
Default:	Disabled
Options:	0 = Disabled 1 = Enabled

• Overall Grade Threshold

Usage:	Sets the threshold for driving the output.
Definition:	Conforms to ISO/IEC 15415 symbol quality grading (A,B,C,D).
Serial Cmd:	< K870 , output on overall grade, overall grade threshold , symbol contrast, symbol contrast threshold, modulation, modulation threshold, reflectance margin, reflectance margin threshold, fixed pattern damage, fixed pattern damage threshold, axial non-uniformity, axial non-uniformity threshold, grid non-uniformity, grid non-uniformity threshold, unused ECC, unused ECC threshold>
Default:	Grade B
Options:	0 = Grade D 1 = Grade C 2 = Grade B 3 = Grade A

• Symbol Contrast

Usage:	Lets the user know if symbol quality is less than acceptable.
Definition:	If enabled, drives Output if grade is under Symbol Contrast Threshold .
Serial Cmd:	< K870 , output on overall grade, overall grade threshold, symbol contrast, symbol contrast threshold, modulation, modulation threshold, reflectance margin, reflectance margin threshold, fixed pattern damage, fixed pattern damage threshold, axial non-uniformity, axial non-uniformity threshold, grid non-uniformity, grid non-uniformity threshold, unused ECC, unused ECC threshold>
Default:	Disabled
Options:	0 = Disabled 1 = Enabled

• Symbol Contrast Threshold

Usage:	Sets the threshold for driving the output.
Definition:	Conforms to ISO/IEC 15415 symbol quality grading (A,B,C,D).
Serial Cmd:	<K870, output on overall grade, overall grade threshold, symbol contrast, symbol contrast threshold , modulation, modulation threshold, reflectance margin, reflectance margin threshold, fixed pattern damage, fixed pattern damage threshold, axial non-uniformity, axial non-uniformity threshold, grid non-uniformity, grid non-uniformity threshold, unused ECC, unused ECC threshold>
Default:	Grade B
Options:	0 = Grade D 1 = Grade C 2 = Grade B 3 = Grade A

• Modulation

Usage:	Lets the user know if symbol quality is less than acceptable.
Definition:	If enabled, drives Output if grade is under Modulation Threshold.
Serial Cmd:	<K870, output on overall grade, overall grade threshold, symbol contrast, symbol contrast threshold, modulation, modulation threshold , reflectance margin, reflectance margin threshold, fixed pattern damage, fixed pattern damage threshold, axial non-uniformity, axial non-uniformity threshold, grid non-uniformity, grid non-uniformity threshold, unused ECC, unused ECC threshold>
Default:	Disabled
Options:	0 = Disabled 1 = Enabled

• Modulation Threshold

Usage:	Sets the threshold for driving the output.
Definition:	Conforms to ISO/IEC 15415 symbol quality grading (A,B,C,D).
Serial Cmd:	<K870, output on overall grade, overall grade threshold, symbol contrast, symbol contrast threshold, modulation, modulation threshold, reflectance margin, reflectance margin threshold, fixed pattern damage, fixed pattern damage threshold, axial non-uniformity, axial non-uniformity threshold, grid non-uniformity, grid non-uniformity threshold, unused ECC, unused ECC threshold>
Default:	Grade B
Options:	0 = Grade D 1 = Grade C 2 = Grade B 3 = Grade A

• Reflectance Margin

Usage:	Lets the user know if symbol quality is less than acceptable.
Definition:	If enabled, drives Output if grade is under Reflectance Margin Threshold .
Serial Cmd:	< K870 , output on overall grade, overall grade threshold, symbol contrast, symbol contrast threshold, modulation, modulation threshold, reflectance margin , reflectance margin threshold, fixed pattern damage, fixed pattern damage threshold, axial non-uniformity, axial non-uniformity threshold, grid non-uniformity, grid non-uniformity threshold, unused ECC, unused ECC threshold>
Default:	Disabled
Options:	0 = Disabled 1 = Enabled

• Reflectance Margin Threshold

Usage:	Sets the threshold for driving the output.
Definition:	Conforms to ISO/IEC 15415 symbol quality grading (A,B,C,D).
Serial Cmd:	< K870 , output on overall grade, overall grade threshold, symbol contrast, symbol contrast threshold, modulation, modulation threshold, reflectance margin, reflectance margin threshold , fixed pattern damage, fixed pattern damage threshold, axial non-uniformity, axial non-uniformity threshold, grid non-uniformity, grid non-uniformity threshold, unused ECC, unused ECC threshold>
Default:	Grade B
Options:	0 = Grade D 1 = Grade C 2 = Grade B 3 = Grade A

• Fixed Pattern Damage

Usage:	Lets the user know if symbol quality is less than acceptable.
Definition:	If enabled, drives Output if grade is under Fixed Pattern Damage Threshold .
Serial Cmd:	< K870 , output on overall grade, overall grade threshold, symbol contrast, symbol contrast threshold, modulation, modulation threshold, reflectance margin, reflectance margin threshold, fixed pattern damage , fixed pattern damage threshold, axial non-uniformity, axial non-uniformity threshold, grid non-uniformity, grid non-uniformity threshold, unused ECC, unused ECC threshold>
Default:	Disabled
Options:	0 = Disabled 1 = Enabled

• Fixed Pattern Damage Threshold

Usage:	Sets the threshold for driving the output.
Definition:	Conforms to ISO/IEC 15415 symbol quality grading (A,B,C,D).
Serial Cmd:	< K870 , output on overall grade, overall grade threshold, symbol contrast, symbol contrast threshold, modulation, modulation threshold, reflectance margin, reflectance margin threshold, fixed pattern damage, fixed pattern damage threshold , axial non-uniformity, axial non-uniformity threshold, grid non-uniformity, grid non-uniformity threshold, unused ECC, unused ECC threshold>
Default:	Grade B
Options:	0 = Grade D 1 = Grade C 2 = Grade B 3 = Grade A

• Axial Non-uniformity

Usage:	Lets the user know if symbol quality is less than acceptable.
Definition:	If enabled, drives Output if grade is under Axial Non-uniformity Threshold .
Serial Cmd:	< K870 , output on overall grade, overall grade threshold, symbol contrast, symbol contrast threshold, modulation, modulation threshold, reflectance margin, reflectance margin threshold, fixed pattern damage, fixed pattern damage threshold, axial non-uniformity, axial non-uniformity threshold, grid non-uniformity, grid non-uniformity threshold, unused ECC, unused ECC threshold>
Default:	Disabled
Options:	0 = Disabled 1 = Enabled

• Axial Non-uniformity Threshold

Usage:	Sets the threshold for driving the output.
Definition:	Conforms to ISO/IEC 15415 symbol quality grading (A,B,C,D).
Serial Cmd:	< K870 , output on overall grade, overall grade threshold, symbol contrast, symbol contrast threshold, modulation, modulation threshold, reflectance margin, reflectance margin threshold, fixed pattern damage, fixed pattern damage threshold, axial non-uniformity, axial non-uniformity threshold , grid non-uniformity, grid non-uniformity threshold, unused ECC, unused ECC threshold>
Default:	Grade B
Options:	0 = Grade D 1 = Grade C 2 = Grade B 3 = Grade A

• Grid Non-uniformity

Usage:	Lets the user know if symbol quality is less than acceptable.
Definition:	If enabled, drives Output if grade is under Grid Non-uniformity Threshold .
Serial Cmd:	<K870, output on overall grade, overall grade threshold, symbol contrast, symbol contrast threshold, modulation, modulation threshold, reflectance margin, reflectance margin threshold, fixed pattern damage, fixed pattern damage threshold, axial non-uniformity, axial non-uniformity threshold, grid non-uniformity , grid non-uniformity threshold, unused ECC, unused ECC threshold>
Default:	Disabled
Options:	0 = Disabled 1 = Enabled

• Grid Non-uniformity Threshold

Usage:	Sets the threshold for driving the output.
Definition:	Conforms to ISO/IEC 15415 symbol quality grading (A,B,C,D).
Serial Cmd:	<K870, output on overall grade, overall grade threshold, symbol contrast, symbol contrast threshold, modulation, modulation threshold, reflectance margin, reflectance margin threshold, fixed pattern damage, fixed pattern damage threshold, axial non-uniformity, axial non-uniformity threshold, grid non-uniformity, grid non-uniformity threshold , unused ECC, unused ECC threshold>
Default:	Grade B
Options:	0 = Grade D 1 = Grade C 2 = Grade B 3 = Grade A

• Unused ECC

Usage:	Lets the user know if symbol quality is less than acceptable.
Definition:	If enabled, drives Output if grade is under Unused ECC Threshold .
Serial Cmd:	<K870, output on overall grade, overall grade threshold, symbol contrast, symbol contrast threshold, modulation, modulation threshold, reflectance margin, reflectance margin threshold, fixed pattern damage, fixed pattern damage threshold, axial non-uniformity, axial non-uniformity threshold, grid non-uniformity, grid non-uniformity threshold, unused ECC , unused ECC threshold>
Default:	Disabled
Options:	0 = Disabled 1 = Enabled

• **Unused ECC Threshold**

Usage:	Sets the threshold for driving the output.
Definition:	Conforms to ISO/IEC 15415 symbol quality grading (A,B,C,D).
Serial Cmd:	< K870 , output on overall grade, overall grade threshold, symbol contrast, symbol contrast threshold, modulation, modulation threshold, reflectance margin, reflectance margin threshold, fixed pattern damage, fixed pattern damage threshold, axial non-uniformity, axial non-uniformity threshold, grid non-uniformity, grid non-uniformity threshold, unused ECC, unused ECC threshold >
Default:	Grade B
Options:	0 = Grade D 1 = Grade C 2 = Grade B 3 = Grade A

8.14. ISO/IEC 15416 Symbol Quality Output 1

Barcode Print Quality Guideline

Supported Symbologies:

- Code 128 / GS1-128
- UPC-A / UPC-E / EAN-13 / EAN-8
- Interleaved 2 of 5 / ITF-14
- Code 39
- Code 93
- Codabar

Minimum Resolution: 4.0 Pixels Per Element

• Output on Overall Grade

Usage:	Lets the user know if symbol quality is less than acceptable.
Definition:	If enabled, drives Output if grade is under Overall Grade Threshold .
Serial Cmd:	<K880, output on overall grade, overall grade threshold, edge determination, edge determination threshold, decode, decode threshold, contrast, contrast threshold, min reflectance, min reflectance threshold, min edge contrast, min edge contrast threshold, modulation, modulation threshold, defects, defects threshold, decodability, decodability threshold, quiet Zone, quiet zone threshold>
Default:	Disabled
Options:	0 = Disabled 1 = Enabled

• Overall Grade Threshold

Usage:	Sets the threshold for driving the output.
Definition:	Conforms to ISO/IEC 15416 symbol quality grading (A,B,C,D).
Serial Cmd:	<K880, output on overall grade, overall grade threshold, edge determination, edge determination threshold, decode, decode threshold, contrast, contrast threshold, min reflectance, min reflectance threshold, min edge contrast, min edge contrast threshold, modulation, modulation threshold, defects, defects threshold, decodability, decodability threshold, quiet Zone, quiet zone threshold>
Default:	Grade B
Options:	0 = Grade D 1 = Grade C 2 = Grade B 3 = Grade A

• **Edge Determination**

Usage:	Lets the user know if symbol quality is less than acceptable.
Definition:	If enabled, drives Output if grade is under Edge Determination Threshold .
Serial Cmd:	<K880, output on overall grade, overall grade threshold, edge determination , edge determination threshold, decode, decode threshold, contrast, contrast threshold, min reflectance, min reflectance threshold, min edge contrast, min edge contrast threshold, modulation, modulation threshold, defects, defects threshold, decodability, decodability threshold, quiet Zone, quiet zone threshold>
Default:	Disabled
Options:	0 = Disabled 1 = Enabled

• **Edge Determination Threshold**

Usage:	Sets the threshold for driving the output.
Definition:	Conforms to ISO/IEC 15416 symbol quality grading (A,B,C,D).
Serial Cmd:	<K880, output on overall grade, overall grade threshold, edge determination, edge determination threshold , decode, decode threshold, contrast, contrast threshold, min reflectance, min reflectance threshold, min edge contrast, min edge contrast threshold, modulation, modulation threshold, defects, defects threshold, decodability, decodability threshold, quiet Zone, quiet zone threshold>
Default:	Grade B
Options:	0 = Grade D 1 = Grade C 2 = Grade B 3 = Grade A

• **Decode**

Usage:	Lets the user know if symbol quality is less than acceptable.
Definition:	If enabled, drives Output if grade is under Decode Threshold .
Serial Cmd:	<K880, output on overall grade, overall grade threshold, edge determination, edge determination threshold, decode, decode threshold, contrast, contrast threshold, min reflectance, min reflectance threshold, min edge contrast, min edge contrast threshold, modulation, modulation threshold, defects, defects threshold, decodability, decodability threshold, quiet Zone, quiet zone threshold>
Default:	Disabled
Options:	0 = Disabled 1 = Enabled

• Decode Threshold

Usage:	Sets the threshold for driving the output.
Definition:	Conforms to ISO/IEC 15416 symbol quality grading (A,B,C,D).
Serial Cmd:	< K880 , output on overall grade, overall grade threshold, edge determination, edge determination threshold, decode, decode threshold , contrast, contrast threshold, min reflectance, min reflectance threshold, min edge contrast, min edge contrast threshold, modulation, modulation threshold, defects, defects threshold, decodability, decodability threshold, quiet Zone, quiet zone threshold>
Default:	Grade B
Options:	0 = Grade D 1 = Grade C 2 = Grade B 3 = Grade A

• Contrast

Usage:	Lets the user know if symbol quality is less than acceptable.
Definition:	If enabled, drives Output if grade is under Contrast Threshold .
Serial Cmd:	< K880 , output on overall grade, overall grade threshold, edge determination, edge determination threshold, decode, decode threshold, contrast , contrast threshold, min reflectance, min reflectance threshold, min edge contrast, min edge contrast threshold, modulation, modulation threshold, defects, defects threshold, decodability, decodability threshold, quiet Zone, quiet zone threshold>
Default:	Disabled
Options:	0 = Disabled 1 = Enabled

• Contrast Threshold

Usage:	Sets the threshold for driving the output.
Definition:	Conforms to ISO/IEC 15416 symbol quality grading (A,B,C,D).
Serial Cmd:	< K880 , output on overall grade, overall grade threshold, edge determination, edge determination threshold, decode, decode threshold, contrast, contrast threshold , min reflectance, min reflectance threshold, min edge contrast, min edge contrast threshold, modulation, modulation threshold, defects, defects threshold, decodability, decodability threshold, quiet Zone, quiet zone threshold>
Default:	Grade B
Options:	0 = Grade D 1 = Grade C 2 = Grade B 3 = Grade A

• **Min Reflectance**

Usage:	Lets the user know if symbol quality is less than acceptable.
Definition:	If enabled, drives Output if grade is under Min Reflectance Threshold .
Serial Cmd:	< K880 , output on overall grade, overall grade threshold, edge determination, edge determination threshold, decode, decode threshold, contrast, contrast threshold, min reflectance , min reflectance threshold, min edge contrast, min edge contrast threshold, modulation, modulation threshold, defects, defects threshold, decodability, decodability threshold, quiet Zone, quiet zone threshold>
Default:	Disabled
Options:	0 = Disabled 1 = Enabled

• **Min Reflectance Threshold**

Usage:	Sets the threshold for driving the output.
Definition:	Conforms to ISO/IEC 15416 symbol quality grading (A,B,C,D).
Serial Cmd:	< K880 , output on overall grade, overall grade threshold, edge determination, edge determination threshold, decode, decode threshold, contrast, contrast threshold, min reflectance, min reflectance threshold , min edge contrast, min edge contrast threshold, modulation, modulation threshold, defects, defects threshold, decodability, decodability threshold, quiet Zone, quiet zone threshold>
Default:	Grade B
Options:	0 = Grade D 1 = Grade C 2 = Grade B 3 = Grade A

• **Min Edge Contrast**

Usage:	Lets the user know if symbol quality is less than acceptable.
Definition:	If enabled, drives Output if grade is under Min Edge Contrast Threshold .
Serial Cmd:	< K880 , output on overall grade, overall grade threshold, edge determination, edge determination threshold, decode, decode threshold, contrast, contrast threshold, min reflectance, min reflectance threshold, min edge contrast , min edge contrast threshold, modulation, modulation threshold, defects, defects threshold, decodability, decodability threshold, quiet Zone, quiet zone threshold>
Default:	Disabled
Options:	0 = Disabled 1 = Enabled

• Min Edge Contrast Threshold

Usage:	Sets the threshold for driving the output.
Definition:	Conforms to ISO/IEC 15416 symbol quality grading (A,B,C,D).
Serial Cmd:	< K880 , output on overall grade, overall grade threshold, edge determination, edge determination threshold, decode, decode threshold, contrast, contrast threshold, min reflectance, min reflectance threshold, min edge contrast, min edge contrast threshold , modulation, modulation threshold, defects, defects threshold, decodability, decodability threshold, quiet Zone, quiet zone threshold>
Default:	Grade B
Options:	0 = Grade D 1 = Grade C 2 = Grade B 3 = Grade A

• Modulation

Usage:	Lets the user know if symbol quality is less than acceptable.
Definition:	If enabled, drives Output if grade is under Modulation Threshold .
Serial Cmd:	< K880 , output on overall grade, overall grade threshold, edge determination, edge determination threshold, decode, decode threshold, contrast, contrast threshold, min reflectance, min reflectance threshold, min edge contrast, min edge contrast threshold, modulation , modulation threshold, defects, defects threshold, decodability, decodability threshold, quiet Zone, quiet zone threshold>
Default:	Disabled
Options:	0 = Disabled 1 = Enabled

• Modulation Threshold

Usage:	Sets the threshold for driving the output.
Definition:	Conforms to ISO/IEC 15416 symbol quality grading (A,B,C,D).
Serial Cmd:	< K880 , output on overall grade, overall grade threshold, edge determination, edge determination threshold, decode, decode threshold, contrast, contrast threshold, min reflectance, min reflectance threshold, min edge contrast, min edge contrast threshold, modulation, modulation threshold , defects, defects threshold, decodability, decodability threshold, quiet Zone, quiet zone threshold>
Default:	Grade B
Options:	0 = Grade D 1 = Grade C 2 = Grade B 3 = Grade A

• Defects

Usage:	Lets the user know if symbol quality is less than acceptable.
Definition:	If enabled, drives Output if grade is under Defects Threshold .
Serial Cmd:	< K880 , output on overall grade, overall grade threshold, edge determination, edge determination threshold, decode, decode threshold, contrast, contrast threshold, min reflectance, min reflectance threshold, min edge contrast, min edge contrast threshold, modulation, modulation threshold, defects , defects threshold, decodability, decodability threshold, quiet Zone, quiet zone threshold>
Default:	Disabled
Options:	0 = Disabled 1 = Enabled

• Defects Threshold

Usage:	Sets the threshold for driving the output.
Definition:	Conforms to ISO/IEC 15416 symbol quality grading (A,B,C,D).
Serial Cmd:	< K880 , output on overall grade, overall grade threshold, edge determination, edge determination threshold, decode, decode threshold, contrast, contrast threshold, min reflectance, min reflectance threshold, min edge contrast, min edge contrast threshold, modulation, modulation threshold, defects, defects threshold , decodability, decodability threshold, quiet Zone, quiet zone threshold>
Default:	Grade B
Options:	0 = Grade D 1 = Grade C 2 = Grade B 3 = Grade A

• Decodability

Usage:	Lets the user know if symbol quality is less than acceptable.
Definition:	If enabled, drives Output if grade is under Decodability Threshold .
Serial Cmd:	< K880 , output on overall grade, overall grade threshold, edge determination, edge determination threshold, decode, decode threshold, contrast, contrast threshold, min reflectance, min reflectance threshold, min edge contrast, min edge contrast threshold, modulation, modulation threshold, defects, defects threshold, decodability , decodability threshold, quiet Zone, quiet zone threshold>
Default:	Disabled
Options:	0 = Disabled 1 = Enabled

• Decodability Threshold

Usage:	Sets the threshold for driving the output.
Definition:	Conforms to ISO/IEC 15416 symbol quality grading (A,B,C,D).
Serial Cmd:	< K880 , output on overall grade, overall grade threshold, edge determination, edge determination threshold, decode, decode threshold, contrast, contrast threshold, min reflectance, min reflectance threshold, min edge contrast, min edge contrast threshold, modulation, modulation threshold, defects, defects threshold, decodability, decodability threshold , quiet Zone, quiet zone threshold>
Default:	Grade B
Options:	0 = Grade D 1 = Grade C 2 = Grade B 3 = Grade A

• Quiet Zone

Usage:	Lets the user know if symbol quality is less than acceptable.
Definition:	If enabled, drives Output if grade is under Quiet Zone Threshold .
Serial Cmd:	< K880 , output on overall grade, overall grade threshold, edge determination, edge determination threshold, decode, decode threshold, contrast, contrast threshold, min reflectance, min reflectance threshold, min edge contrast, min edge contrast threshold, modulation, modulation threshold, defects, defects threshold, decodability, decodability threshold, quiet Zone , quiet zone threshold>
Default:	Disabled
Options:	0 = Disabled 1 = Enabled

• Quiet Zone Threshold

Usage:	Sets the threshold for driving the output.
Definition:	Conforms to ISO/IEC 15416 symbol quality grading (A,B,C,D).
Serial Cmd:	< K880 , output on overall grade, overall grade threshold, edge determination, edge determination threshold, decode, decode threshold, contrast, contrast threshold, min reflectance, min reflectance threshold, min edge contrast, min edge contrast threshold, modulation, modulation threshold, defects, defects threshold, decodability, decodability threshold, quiet Zone, quiet zone threshold >
Default:	Grade B
Options:	0 = Grade D 1 = Grade C 2 = Grade B 3 = Grade A

8.15. ISO/IEC 29158 Symbol Quality Output 1

Automatic Identification and data capture – Direct Part Mark (DMP) Quality

Supported symbologies:

- Data Matrix ECC200

Minimum Resolution: 6.0 Pixels Per Element

• Output on Overall Grade

Usage:	Lets the user know if symbol quality is less than acceptable.
Definition:	If enabled, drives Output if grade is under Overall Grade Threshold.
Serial Cmd:	< K890 , output on overall grade, overall grade threshold, cell contrast, cell contrast threshold, cell modulation, cell modulation threshold, fixed pattern damage, fixed pattern damage threshold, axial non-uniformity, axial non-uniformity threshold, grid non-uniformity, grid non-uniformity threshold, unused ECC, unused ECC threshold>
Default:	Disabled
Options:	0 = Disabled 1 = Enabled

• Overall Grade Threshold

Usage:	Sets the threshold for driving the output.
Definition:	Conforms to ISO/IEC 29158 symbol quality grading (A,B,C,D).
Serial Cmd:	< K890 , output on overall grade, overall grade threshold , cell contrast, cell contrast threshold, cell modulation, cell modulation threshold, fixed pattern damage, fixed pattern damage threshold, axial non-uniformity, axial non-uniformity threshold, grid non-uniformity, grid non-uniformity threshold, unused ECC, unused ECC threshold>
Default:	Grade B
Options:	0 = Grade D 1 = Grade C 2 = Grade B 3 = Grade A

• Cell Contrast

Usage:	Lets the user know if symbol quality is less than acceptable.
Definition:	If enabled, drives Output if grade is under Symbol Contrast Threshold .
Serial Cmd:	< K890 , output on overall grade, overall grade threshold, cell contrast , cell contrast threshold, cell modulation, cell modulation threshold, fixed pattern damage, fixed pattern damage threshold, axial non-uniformity, axial non-uniformity threshold, grid non-uniformity, grid non-uniformity threshold, unused ECC, unused ECC threshold>
Default:	Disabled
Options:	0 = Disabled 1 = Enabled

• Cell Contrast Threshold

Usage:	Sets the threshold for driving the output.
Definition:	Conforms to ISO/IEC 29158 symbol quality grading (A,B,C,D).
Serial Cmd:	< K890 , output on overall grade, overall grade threshold, cell contrast, cell contrast threshold , cell modulation, cell modulation threshold, fixed pattern damage, fixed pattern damage threshold, axial non-uniformity, axial non- uniformity threshold, grid non-uniformity, grid non-uniformity threshold, unused ECC, unused ECC threshold>
Default:	Grade B
Options:	0 = Grade D 1 = Grade C 2 = Grade B 3 = Grade A

• Cell Moduration

Usage:	Lets the user know if symbol quality is less than acceptable.
Definition:	If enabled, drives Output if grade is under Cell Moduration Threshold .
Serial Cmd:	< K890 , output on overall grade, overall grade threshold, cell contrast, cell contrast threshold, cell modulation , cell modulation threshold, fixed pattern damage, fixed pattern damage threshold, axial non-uniformity, axial non- uniformity threshold, grid non-uniformity, grid non-uniformity threshold, unused ECC, unused ECC threshold>
Default:	Disabled
Options:	0 = Disabled 1 = Enabled

• Cell Moduration Threshold

Usage:	Sets the threshold for driving the output.
Definition:	Conforms to ISO/IEC 29158 symbol quality grading (A,B,C,D).
Serial Cmd:	< K890 , output on overall grade, overall grade threshold, cell contrast, cell contrast threshold, cell modulation, cell modulation threshold , fixed pattern damage, fixed pattern damage threshold, axial non-uniformity, axial non- uniformity threshold, grid non-uniformity, grid non-uniformity threshold, unused ECC, unused ECC threshold>
Default:	Grade B
Options:	0 = Grade D 1 = Grade C 2 = Grade B 3 = Grade A

• Fixed Pattern Damage

Usage:	Lets the user know if symbol quality is less than acceptable.
Definition:	If enabled, drives Output if grade is under Fixed Pattern Damage Threshold .
Serial Cmd:	< K890 , output on overall grade, overall grade threshold, cell contrast, cell contrast threshold, cell modulation , cell modulation threshold, fixed pattern damage, fixed pattern damage threshold, axial non-uniformity, axial non- uniformity threshold, grid non-uniformity, grid non-uniformity threshold, unused ECC, unused ECC threshold>
Options:	0 = Disabled 1 = Enabled

• Fixed Pattern Damage Threshold

Usage:	Sets the threshold for driving the output.
Definition:	Conforms to ISO/IEC 29158 symbol quality grading (A,B,C,D).
Serial Cmd:	< K890 , output on overall grade, overall grade threshold, cell contrast, cell contrast threshold, cell modulation, cell modulation threshold, fixed pattern damage, fixed pattern damage threshold , axial non-uniformity, axial non- uniformity threshold, grid non-uniformity, grid non-uniformity threshold, unused ECC, unused ECC threshold>
Default:	Grade B
Options:	0 = Grade D 1 = Grade C 2 = Grade B 3 = Grade A

• Axial Non-uniformity

Usage:	Lets the user know if symbol quality is less than acceptable.
Definition:	If enabled, drives Output if grade is under Axial Non-uniformity Threshold .
Serial Cmd:	< K890 , output on overall grade, overall grade threshold, cell contrast, cell contrast threshold, cell modulation, cell modulation threshold, fixed pattern damage, fixed pattern damage threshold, axial non-uniformity , axial non- uniformity threshold, grid non-uniformity, grid non-uniformity threshold, unused ECC, unused ECC threshold>
Default:	Disabled
Options:	0 = Disabled 1 = Enabled

• Axial Non-uniformity Threshold

Usage:	Sets the threshold for driving the output.
Serial Cmd:	< K890 , output on overall grade, overall grade threshold, cell contrast, cell Definition: Conforms to ISO/IEC 29158 symbol quality grading (A,B,C,D). contrast threshold, cell modulation, cell modulation threshold, fixed pattern damage, fixed pattern damage threshold, axial non-uniformity, axial non- uniformity threshold , grid non-uniformity, grid non-uniformity threshold, unused ECC, unused ECC threshold>
Default:	Grade B
Options:	0 = Grade D 1 = Grade C 2 = Grade B 3 = Grade A

• Grid Non-uniformity

Usage:	Lets the user know if symbol quality is less than acceptable.
Definition:	If enabled, drives Output if grade is under Grid Non-uniformity Threshold .
Serial Cmd:	< K890 , output on overall grade, overall grade threshold, cell contrast, cell contrast threshold, cell modulation, cell modulation threshold, fixed pattern damage, fixed pattern damage threshold, axial non-uniformity, axial non- uniformity threshold, grid non-uniformity , grid non-uniformity threshold, unused ECC, unused ECC threshold>
Default:	Disabled
Options:	0 = Disabled 1 = Enabled

• Grid Non-uniformity Threshold

Usage:	Sets the threshold for driving the output.
Definition:	Conforms to ISO/IEC 29158 symbol quality grading (A,B,C,D).
Serial Cmd:	< K890 , output on overall grade, overall grade threshold, cell contrast, cell contrast threshold, cell modulation, cell modulation threshold, fixed pattern damage, fixed pattern damage threshold, axial non-uniformity, axial non- uniformity threshold, grid non-uniformity, grid non-uniformity threshold , unused ECC, unused ECC threshold>
Default:	Grade B
Options:	0 = Grade D 1 = Grade C 2 = Grade B 3 = Grade A

• **Unused ECC**

Usage:	Lets the user know if symbol quality is less than acceptable.
Definition:	If enabled, drives Output if grade is under Unused ECC Threshold .
Serial Cmd:	< K890 , output on overall grade, overall grade threshold, cell contrast, cell contrast threshold, cell modulation, cell modulation threshold, fixed pattern damage, fixed pattern damage threshold, axial non-uniformity, axial non-uniformity threshold, grid non-uniformity, grid non-uniformity threshold, unused ECC , unused ECC threshold>
Default:	Disabled
Options:	0 = Disabled 1 = Enabled

• **Unused ECC Threshold**

Usage:	Sets the threshold for driving the output.
Definition	Conforms to ISO/IEC 29158 symbol quality grading (A,B,C,D).H
Serial Cmd:	< K890 , output on overall grade, overall grade threshold, cell contrast, cell contrast threshold, cell modulation, cell modulation threshold, fixed pattern damage, fixed pattern damage threshold, axial non-uniformity, axial non-uniformity threshold, grid non-uniformity, grid non-uniformity threshold, unused ECC, unused ECC threshold >
Default:	Grade B
Options:	0 = Grade D 1 = Grade C 2 = Grade B 3 = Grade A

8.16. Diagnostics Output 1

Serial Cmd:	<K790,unused 1,service unit>
Default:	0
Options:	0 = Disabled

Service Unit

When **Diagnostic Warning** is enabled, the **Output On** configuration has no effect. The output will remain active as long as one of the diagnostic warning conditions is met. The output will become inactive once it detects that there are no diagnostic warning conditions.

Definition:	Allows the user to set up the output to toggle to active when the service timer has expired. This condition will only be held for one service timer click.  NOTE! This feature cannot be used if the reader is in a Continuous Read mode.
Serial Cmd:	<K790,unused 1,service unit>
Default:	0
Options:	0 = Disabled

8.17. Other Outputs

Configurable Output 2

Serial Cmd: <K811,output on,output state,pulse width,output mode>

Trend Analysis Output 2

Serial Cmd: <K781,trend analysis mode,trigger evaluation period,number to output on>

ISO/IEC 16022 Symbol Quality Output 2

Serial Cmd: <K801,output on symbol contrast,symbol contrast threshold,output on print growth,print growth threshold,output on axial non-uniformity,axial non- uniformity threshold,output on UEC,UEC threshold>

ISO/IEC 15415 Symbol Quality Output 2

Serial Cmd: <K871, output on overall grade, overall grade threshold, symbol contrast, symbol contrast threshold, modulation, modulation threshold, reflectance margin, reflectance margin threshold, fixed pattern damage, fixed pattern damage threshold, axial non-uniformity, axial non-uniformity threshold, grid non-uniformity, grid non-uniformity threshold, unused ECC, unused ECC threshold>

ISO/IEC 15416 Symbol Quality Output 2

Serial Cmd: <K881, output on overall grade, overall grade threshold, edge determination, edge determination threshold, decode, decode threshold, contrast, contrast threshold, min reflectance, min reflectance threshold, min edge contrast, min edge contrast threshold, modulation, modulation threshold, defects, defects threshold, decodability, decodability threshold, quiet Zone, quiet zone threshold >

ISO/IEC 29158 Symbol Quality Output 2

Serial Cmd: <K891, output on overall grade, overall grade threshold, cell contrast, cell contrast threshold, cell modulation, cell modulation threshold, fixed pattern damage, fixed pattern damage threshold, axial non-uniformity, axial non- uniformity threshold, grid non-uniformity, grid non-uniformity threshold, unused ECC, unused ECC threshold>

Diagnostics Output 2

Serial Cmd: <K791,unused 1,service unit>

Configurable Output 3

Serial Cmd: <K812,output on,output state,pulse width,output mode>

Output On Output 3

Usage:	This option provides discrete signalling to host software to control external devices such as PLCs and relays. It is useful for routing, sorting, and preventing mis-packaging and mis-routing.
Definition:	Sets the discrete output functions for specific user-selected conditions. Allows the user to determine when an output (or outputs) will be activated.
Serial Cmd:	<K812,output on,output state,pulse width,output mode>
Default:	Mismatch or No-Read
Options:	0 = Mismatch or No-Read 1 = Match (or Good Read) 2 = Mismatch 3 = No-Read 4 = Trend Analysis 5 = Symbol Quality 6 = Diagnostic Warning 7 = In Read Cycle 8 = Use as External Illumination Strobe

• Use as External Illumination Strobe

Definition: Asserts the external illumination strobe output during image capture.

Trend Analysis Output 3

Serial Cmd: <K782,trend analysis mode,trigger evaluation period,number to output on>

ISO/IEC 16022 Symbol Quality Output 3

Serial Cmd: <K802,output on symbol contrast,symbol contrast threshold,output on print growth,print growth threshold,output on axial non-uniformity,axial non-uniformity threshold,output on UEC,UEC threshold>

ISO/IEC 15415 Symbol Quality Output 3

Serial Cmd: <K872, output on overall grade, overall grade threshold, symbol contrast, symbol contrast threshold, modulation, modulation threshold, reflectance margin, reflectance margin threshold, fixed pattern damage, fixed pattern damage threshold, axial non-uniformity, axial non-uniformity threshold, grid non-uniformity, grid non-uniformity threshold, unused ECC, unused ECC threshold>

ISO/IEC 15416 Symbol Quality Output 3

Serial Cmd: <K882, output on overall grade, overall grade threshold, edge determination, edge determination threshold, decode, decode threshold, contrast, contrast threshold, min reflectance, min reflectance threshold, min edge contrast, min edge contrast threshold, modulation, modulation threshold, defects, defects threshold, decodability, decodability threshold, quiet Zone, quiet zone threshold >

ISO/IEC 29158 Symbol Quality Output 3

Serial Cmd: <K892, output on overall grade, overall grade threshold, cell contrast, cell contrast threshold, cell modulation, cell modulation threshold, fixed pattern damage, fixed pattern damage threshold, axial non-uniformity, axial non-uniformity threshold, grid non-uniformity, grid non-uniformity threshold, unused ECC, unused ECC threshold>

Diagnostics Output 3

Serial Cmd: <K792,unused 1,service unit>

8.18. Power On/Reset Counts



NOTE!

Power On/Reset Counts is a read-only command.

- **Power-On**

Serial Cmd: <K406,**power-on**,resets,power-on saves,power-on flash saves>

Power-On uses a 16-bit counter that increments each time the reader is powered-on.

- **Resets**

Serial Cmd: <K406,power-on,**resets**,power-on saves,power-on flash saves>

Resets uses a 16-bit counter that increments each time the reader is reset. This value is reset at power-on.

- **Power-On Saves**

Serial Cmd: <K406,power-on,resets,**power-on saves**,power-on flash saves>

Power-On Saves uses a 16-bit counter that increments each time an reader setting is saved for power-on with a <Z> command.

- **Power-On Flash Saves**

Serial Cmd: <K406,power-on,resets,**power-on saves**,power-on flash saves>

Power-On Flash Saves uses a 16-bit counter that increments each time an reader setting is saved to the customer parameter section of flash memory with a <Zc> command.

8.19. Time Since Reset



NOTE!

Time Since Reset is a read-only command.

- **Hours**

Serial Cmd: <K407,**hours**,minutes>

Default: 16-bit counter (0 to 65535)

Hours uses a 16-bit counter that increments every 60 minutes.

- **Minutes**

Serial Cmd: <K407,hours,**minutes**>

Default: 16-bit counter (0 to 60)

Minutes uses a 16-bit counter that increments every 60 seconds.



NOTE!

Time counts are reset at power-on, but not with an <A> or <Z> command.

8.20. Service Message

When Service Message is enabled, a message of up to 10 ASCII characters is sent whenever the system detects that the service timer's limit has been reached. The service timer is reset at power-on, meaning that the service timer's limit is the amount of time since last reset. Service timer increments can be set in seconds or minutes.

Serial Cmd: <K409,status,service message,threshold,resolution>
Default: 0
Options: 0 = Disabled
 1 = Enabled

• Service Message

Serial Cmd: <K409,status,**service message**,threshold,resolution>
Default: SERVICE
Options: An ASCII string between 1 and 10 characters.

• Threshold

Serial Cmd: <K409,status,service message,threshold,**resolution**>
Default: 300 (5 minutes)
Options: 1 to 65535

• Resolution

Serial Cmd: <K409,status,service message,threshold,**resolution**>
Default: Seconds
Options: 0 = Seconds
 1 = Minutes

8.21. User-Assigned Name

Definition: **User-Assigned Name** allows you to enter any string of ASCII characters to help you identify your reader. The user-assigned name is saved at power-on and custom defaults, and is stored as a “sticky” parameter so it cannot be defaulted without a <Zrdall> or <K412d> command.

Serial Cmd: <K412,user-assigned name>
Options: ASCII string, up to 19 characters

8.22. Output Object Info

Output Frame Number

Serial Cmd: <K734,output frame number,output coordinates>
Default: Disabled
Options: 0 = Disabled
1 = Enabled

- **Disabled**

When **Output Frame Number** is set to **Disabled**, the frame number is not output as part of the symbol data.

- **Enabled**

When **Output Frame Number** is set to **Enabled**, the number of the frame in which the symbol was first decoded is attached to the symbol output information. The output format is “Fnnn”, where “nnn” is a 3- digit decimal value from 0 to 255. The frame number rolls over to 0 once it passes 255.

If this feature is enabled, the frame information will follow the symbol data, and it will precede any symbol quality data (if symbol quality settings are enabled – see “9.3. Symbol Quality Separator/Output Mode” on page 176. The symbol quality separator is located between the end of the already-formatted data and the “F” that precedes the frame number.

Output Coordinates

Serial Cmd: <K734,output frame number,output coordinates>
Default: Disabled
Options: 0 = Disabled
1 = Enabled

- **Disabled**

When **Output Coordinates** is set to **Disabled**, the coordinates are not output as part of the symbol data.

- **Enabled**

When **Output Coordinates** is set to **Enabled**, the four sets of object coordinates for the first successfully decoded symbol are attached to the symbol data output in the following format:

“(nnn,mmm)”, where “nnn” is a 3-digit X-coordinate and “mmm” is a 3-digit Y-coordinate. The validation separator is located between the end of the already formatted data and the first coordinate point. The point with the lowest X + Y sum will be output first, followed by the next three points in a clockwise direction.

Example:

(032,040)(287,056)(287,279)(048,271)

8.23. Database Identifier Output

Usage: Useful in keeping track of which database entries read which symbols. Serial Cmd:
<K759,status,separator>
Default: 0
Options: 0 = Disabled
1 = Enabled

Output Status

- **Disabled**

When this command is disabled, no database identifier information will be output.

- **Enabled**

When this command is enabled, the reader will append a two-digit number and the characters "DB" to the data output following the separator for each symbol decoded using **Configuration Database**. For example, if the separator is an underscore character and the second database entry reads a symbol encoded with "data capture" during the read cycle, the symbol data output will be "data capture_DB02". If the database is not active, no identifiers will be attached to output.

Separator

Usage: The separator character separates the symbol data from the database identifier.
Serial Cmd: <K759,status,separator>
Default: <space>
Options: Any ASCII character.

8.24. Quality Output

Separator

Definition: The separator character separates quality output data from symbol data.
Serial Cmd: <**K704,separator**,decodes per trigger status>
Default: ,
Options: Any ASCII character.

Decodes per Trigger Status

Definition: When this feature is enabled, the reader enters a state where it processes frames as configured until the end of a read cycle, with or without a successful symbol decode. When the read cycle ends, the reader outputs any decoded symbol data along with the decodes per trigger count.
Serial Cmd: <**K704,separator,decodes per trigger status**>
Default: 0
Options: 0 = Disabled
1 = Enabled

8.25. Image Push to Host

Stored Image Type

Definition: **Stored Image Type** defines what kind of image you want to log in a read cycle.
Serial Cmd: <**K763,image storage status,stored image type**,image storage,image file format,image quality,image scale,file save options>
Default: No Read
Options: 1 = Good Read
2 = No Read
3 = Good Read + No Read
4 = Match
8 = Mismatch
12 = Match + Mismatch
15 = Good Read + No Read + Match + Mismatch

Image Storage

Definition:	Image Storage defines which image will be stored within a read cycle. <ul style="list-style-type: none">• Good Read/Match/Mismatch: First qualified image or all qualified images.• No Read: First image or all images that have an IP report.
Serial Cmd:	< K763 ,image storage status,stored image type, image storage ,image file format,image quality,image scale,file save options>
Default:	First Image in a Read Cycle
Options:	0 = First Image in a Read Cycle 1 = All Images in a Read Cycle

Image File Format

Definition:	Image File Format defines the image format you want to use.
Serial Cmd:	< K763 ,image storage status,stored image type,image storage, image file format ,image quality,image scale,file save options>
Default:	PNG
Options:	0 = PNG 1 = JPG

Image Quality

Definition:	Image Quality defines the amount of image compression you want the image to have.
Serial Cmd:	< K763 ,image storage status,stored image type,image storage,image file format,image quality,image scale,file save options>
Default:	90
Options:	1 to 100

Image Scale

Definition:	Image Scale defines the size you want the image to be.
Serial Cmd:	< K763 ,image storage status,stored image type,image storage,image file format, image quality ,image scale,file save options>
Default:	Full
Options:	0 = Full 1 = 1/4 th 2 = 1/8 th

File Save Options

Definition:	File Save Options determines which files you want to save.
Serial Cmd:	< K763 ,image storage status,stored image type,image storage,image file format,image quality,image scale, file save options >
Default:	Image
Options:	1 = Image 2 = Read Cycle Report 3 = Image + Read Cycle Report

8.26. Image Push to Host Detailed Setup

Image Storage Location

Definition: Defines where the saved image is going to be stored.



NOTE!

When saving images to **RAM**, the system is limited to the actual RAM space available in the system.

The number of images that can be saved depends on the **Max RAM Drive Size**. The actual system path is `/imagesd0/Images/`. When saving images to FTP, the path is `<last 6 digits of device's MAC Address>_Images/` on the host FTP director. Note that the FTP server needs to grant the user with create directory rights as the system will need to create a directory on the FTP server to store all uploaded images.

File save scheme: The image file will be posted with its system reset count, followed by its read cycle i.d., followed by its image i.d., followed by its stored image type defined in `<K763>`, as follows:

```
<last 6 digits of device's MAC Address>_<system total reset count>_<read cycle id>_<image id>_<save image type>.{png, jpg}
<last 6 digits of device's MAC Address>_<system total reset count>_<read cycle id>_<image id>_readreport.xml
```

Serial Cmd: `<K764,image storage location,FTP host info,transfer optimization,RAM drive size in MB,save image until,action at image storage limit>`

Default: RAM

Options: 0 = RAM

1 = FTP

FTP Host Info

Definition: `wenglor|pass@192.168.188.1:21` signifies a the user with **wenglor** at **192.168.188.1** FTP server on port **21** with **pass** as the FTP login password.



NOTE!

If port is not defined with the FTP server address, it will default to port 21.

Serial Cmd: `<K764,image storage location,FTP host info,transfer optimization,RAM drive size in MB,save image until,action at image storage limit>`

Default: `"user|pass@xxx.xxx.xxx.xxx:21"`

Options: Maximum 255 characters including the characters "|", "@", and ".".

Transfer Optimization

Definition: Transfer Optimization defines how the image is going to be stored in triggered captured modes.
Serial Cmd: <K764,image storage location,FTP host info,transfer optimization,RAM drive size in MB,save image until,action at image storage limit>
Default: Speed
Options: 0 = Speed (Lossy)
 1 = Accuracy (Lossless)

• Speed (Lossy)

Images will be saved when possible. Some images may be dropped.

SOR = Start of Read Cycle

EOR = End of Read Cycle

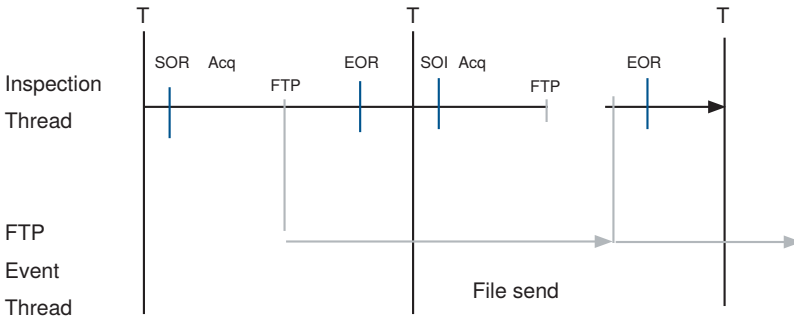

• Accuracy (Lossless)

Every image in read cycle is transferred. The read cycle may be delayed due to image saving since each transfer will need to be finished before the end of the read cycle.

SOR = Start of Read Cycle

EOR = End of Read Cycle

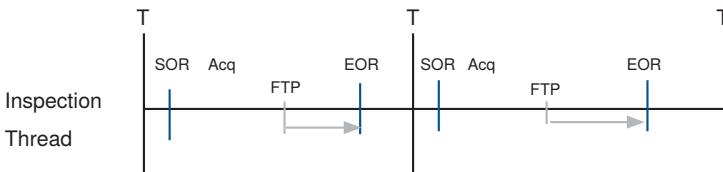

RAM Drive Size in MB

Definition: This defines the maximum RAM Drive size on the system. It is also limited to the memory available on the system and affects the max. rapid image count in <K241> since the onboard memory may be taken up by the RAM Drive. Images may not be saved if the RAM Drive is not large enough to store all the images in the current read cycle and if **Image Storage Location** is set to **FTP** with **Image Save Mode** set to **Speed**. If Image Storage Location is set to **FTP** with Image Save Mode set to **Accuracy**, all images in the read cycle will be transferred to the FTP host but the read cycle may be delayed.

Serial Cmd: <K764,image storage location,FTP host info,transfer optimization,RAM drive size in MB,save image until,action at image storage limit>

Default: 20

Options: 1 to 50



NOTE!

The number of images that can be save in the RAM drive vary depending on model, RAM drive size setting, image file format.

The following is a list of the number of images to be saved when the **Image File Format** is **PNG** and, the **Image Scale** is **Full**.

Resolution	No. of images to be saved	
	default: 20 MB	Max.: 50 MB
0.3 Mpix	57	143
1.2 Mpix	16	42
5 Mpix	4	10

Save Image Until

Definition: This defines how long the image will be stored in the system when the **Image Storage Location** is **RAM**.
If set to **New Read Cycle**, the saved image will be erased upon entering the next read cycle.
If set to **System Reset**, the saved image will be erased upon the next system reset.

Serial Cmd: <K764,image storage location,FTP host info,transfer optimization,RAM drive size in MB,save image until,action at image storage limit>

Default: New Read Cycle

Options: 1 = New Read Cycle
2 = System Reset

Action at Image Storage Limit

Definition: This defines what to do when **Action at Storage Full** is reached and when images are saved on **RAM**. When this setting is set to **Erase Oldest First**, the oldest images in the current read cycle will be erased.

Serial Cmd: <**K764**,image storage location,FTP host info,transfer optimization,RAM drive size in MB,save image until,**action at image storage limit**>

Default: Stop

Options: 0 = Stop
1 = Erase Oldest First

9. Symbol Quality

This section describes parameters that, when enabled, will output detailed symbol quality evaluations.

Symbol Quality Serial Commands	175
Overview of Symbol Quality	175
Symbol Quality Separator/Output Mode	176
ISO/IEC 16022 Symbol Quality Output	177
wenglor Symbol Quality Output	179
ISO/IEC 15415 Symbol Quality Output	182
ISO/IEC 15416 Symbol Quality Output	186
ISO/IEC 29158 Symbol Quality Output	191

9.1. Symbol Quality Serial Commands

Symbol Quality Separator / Output Mode	<K708,symbol quality separator, output mode>
ISO/IEC 16022 Symbol Quality Output	<K709,symbol contrast,print growth,axial non-uniformity, unused ECC>
wenglor Symbol Quality Output	<K710,percent cell damage,total read time,capture time,locate time,decode time,pixels per element,ECC level,matrix size,quiet zone,symbol angle>
ISO/IEC 15415 Symbol Quality Output	<K725, aperture, overall, contrast, modulation, reflectance margin, fixed pattern damage, axial nonuniformity, grid nonuniformity, unused ECC>
ISO/IEC 15416 Symbol Quality Output	<K726, aperture, overall, edge determination, decode, contrast, minimum reflectance, minimum edge contrast, modulation, defects, decodability, quiet zone>
ISO/IEC 29158 Symbol Quality Output	<K727, overall, cell contrast, cell modulation, fixed pattern damage, axial nonuniformity, grid nonuniformity, unused ECC>

9.2. Overview of Symbol Quality

C5PC supports the following standards.

ISO code pint quality grading	Supported code
ISO/IEC 15415	DataMatrix (ECC200, GS1)
	QR Code ^{*1}
	Micro QR
ISO/IEC TR 29158	DataMatrix (ECC200, GS1)
	Code 128/GS1-12
	UPC/EAN(JAN)
ISO/IEC 15416	ITF
	Code 39
	Code 93
	Codabar
ISO/IEC 16022 ^{*2}	DataMatrix (ECC200, GS1)

*1 QR Code unique grading, VID/FID, are not supported.

*2 The evaluation standard of ISO/IEC 16022 is presently integrated to ISO/IEC 15415. Information about symbol quality and timing can be appended to symbol data by enabling specific evaluation parameters. The order in which these values are appended corresponds to the order in ISO/IEC 16022 Parameters, wenglor Grading Parameters, ISO/IEC 15415 Parameters, ISO/IEC 15416 Parameters, and ISO/IEC 29158 Parameters. Symbol Quality parameters are separated into ISO/IEC 16022 Symbol Quality Output, wenglor Symbol Quality Output, ISO/IEC 15415 Symbol Quality Output, ISO/IEC 15416 Symbol Quality Output, and ISO/IEC 29158 Symbol Quality Output.

Total Read Time, Symbol Quality Separator, and Output Mode are common parameters.

9.3. Symbol Quality Separator/Output Mode

Symbol Quality Separator applies to all Symbol Quality groups: ISO/IEC 16022 Symbol Quality Output, ISO/IEC 15415 Symbol Quality Output, ISO/IEC 15416 Symbol Quality Output, ISO/IEC 29158 Symbol Quality Output, and wenlgor Symbol Quality Output.

Symbol Quality Separator

Definition: Inserts a separator between each enabled field of the symbol quality output.
Serial Cmd: <**K708,symbol quality separator,output mode**>
Default: <**SP**> (space character)
Options: Any ASCII character.

Output Mode



NOTE!

Output Mode applies to ISO/IEC 16022 symbol quality parameters, ISO/IEC 15415 symbol quality parameters, ISO/IEC 15416 symbol quality parameters, and ISO/IEC 29158 symbol quality parameters.

Definition: Output Mode specifies how the output parameters, if enabled, are format- ted.
Serial Cmd: <**K708,symbol quality separator,output mode**>
Default: **Grade**
Options: **0 = Grade**
 1 = Value
 2 = Score

- **Grade**

If in **Grade Mode**, a grade (A,B,C,D,F) is appended to the symbol data.

- **Value**

If in **Value Mode**, the calculated value for the given parameter is appended to the symbol data.

- **Score**

If in **Score Mode**, a percentage of passing lines for that parameter is appended to the symbol data.

9.4. ISO/IEC 16022 Symbol Quality Output

Symbol Quality Parameters for Data Matrix symbols specified by ISO/IEC 16022.

Symbol Contrast

Usage: Lets the user know if contrast settings are less than acceptable.

Definition: All the pixels that fall within the area of the test symbol, including its required zone, will be sorted by their reflectance values to select the darkest 10% and the lightest 10% of the pixels. The arithmetic mean of the darkest and the lightest pixels is calculated and the difference of the two means is the Symbol Contrast.
(ANSI) Symbol Contrast grading is defined this way:
A (4.0) if $SC > 70\%$
B (3.0) if $SC > 55\%$
C (2.0) if $SC > 40\%$
D (1.0) if $SC > 20\%$
F (0.0) if $SC < 20\%$

If enabled, the symbol contrast is appended to the symbol data according to the **ISO/IEC 16022 Symbol Quality Output Mode** setting.

Serial Cmd: <K709,symbol contrast,print growth,axial non-uniformity,UEC>

Default: Disabled

Options: 0 = Disabled
1 = Enabled

Print Growth

Definition: The extent to which dark or light markings appropriately fill or exceed their module boundaries. These values are determined by counting pixels in the clock pattern of the binary digitized image, then comparing it to a nominal value and minimum and maximum values. The print growth grade is defined in this way:
A (4.0) if $-0.50 < PG < 0.50$
B (3.0) if $-0.70 < PG < 0.70$
C (2.0) if $-0.85 < PG < 0.85$
D (1.0) if $-1.00 < PG < 1.00$
F (0.0) if $PG < -1.00$ or $PG > 1.00$

If enabled, the print growth is appended to the symbol data according to the ISO/IEC 16022 Symbol Quality Output Mode setting.

Serial Cmd: <K709,symbol contrast,print growth,axial non-uniformity,UEC>

Default: Disabled

Options: 0 = Disabled
1 = Enabled

Axial Non-Uniformity (Data Matrix Only)

Definition: Axial non-uniformity is a measure of how much the sampling point spacing differs from one axis to another, namely $AN = \text{abs}(X_{AVG} - Y_{AVG}) / ((X_{AVG} + Y_{AVG})/2)$ where $\text{abs}()$ yields the absolute value. If a symbology has more than two major axes, then AN is computed for those two average spacings which differ the most. (ANSI) axial non-uniformity grading is defined this way:

- A (4.0) if $AN < .06$
- B (2.0) if $AN < .08$
- C (2.0) if $AN < .10$
- D (1.0) if $AN < .12$
- F (0.0) if $AN > .12$

If enabled, the axial non-uniformity is appended to the symbol data according the **ISO/IEC 16022 Symbol Quality Output Mode** setting.

Serial Cmd: <K709,symbol contrast,print growth,axial non-uniformity,UEC>
Default: **Disabled**
Options: **0 = Disabled**
 1 = Enabled

Unused Error Correction (Data Matrix Only)

Definition: The correction capacity of Reed-Solomon decoding is expressed in the equation: $e + 2d < d - p$, where e is the number of erasures, d is the number of error correction code words, and p is the number of code words reserved for error detection.

- A (4.0) if $UEC > .62$
- B (3.0) if $UEC > .50$
- C (2.0) if $UEC > .37$
- D (1.0) if $UEC > .25$
- F (0.0) if $UEC < .25$

If enabled, the UEC is appended to the symbol data according to the ISO/IEC 16022 Symbol Quality Output Mode setting.

Serial Cmd: <K709,symbol contrast,print growth,axial non-uniformity,UEC>
Default: Disabled
Options: 0 = Disabled
 1 = Enabled

9.5. wenglor Symbol Quality Output

Percent Cell Damage (Data Matrix Only)

Definition: When this feature is enabled, the cell damage percentage is appended to data output.
Serial Cmd: <K710,percent cell damage,total read time,capture time,locate time,decode time,pixels per element,ECC level,matrix size,quiet zone,symbol angle>
Default: **Disabled**
Options: **0 = Disabled**
1 = Enabled

Total Read Time

Definition: The time that transpires between the image capture and the output of the decoded data, including locate time. When enabled, the total read time is appended to the symbol data.
Serial Cmd: <K710,percent cell damage,total read time,capture time,locate time,decode time,pixels per element,ECC level,matrix size,quiet zone,symbol angle>
Default: **Disabled**
Options: **0 = Disabled**
1 = Enabled

Capture Time

Definition: Capture time (in milliseconds) is a fixed “overhead” that includes the time of capture and transfer of the image. When enabled, the capture time is appended to the symbol data.
Serial Cmd: <K710,percent cell damage,total read time,capture time,locate time,decode time,pixels per element,ECC level,matrix size,quiet zone,symbol angle>
Default: **Disabled**
Options: **0 = Disabled**
1 = Enabled

Locate Time

Definition: The time in milliseconds from the start of image processing until the symbol has been located and is ready to be decoded. When enabled, the locate time is appended to the symbol data.
Serial Cmd: <K710,percent cell damage,total read time,capture time,locate time,decode time,pixels per element,ECC level,matrix size,quiet zone,symbol angle>
Default: **Disabled**
Options: **0 = Disabled**
1 = Enabled

Decode Time

Definition:	The time in milliseconds required to decode a symbol. When enabled, the decode time is appended to the symbol data.
Serial Cmd:	< K710 ,percent cell damage,total read time,capture time,locate time, decode time ,pixels per element,ECC level,matrix size,quiet zone,symbol angle>
Default:	Disabled
Options:	0 = Disabled 1 = Enabled

Pixel Per Element (Data Matrix Only)

Definition:	The number of pixels for each element, either dark or light for both x and y directions. When enabled, the pixels per element value is appended to the symbol data.
Serial Cmd:	< K710 ,percent cell damage,total read time,capture time,locate time,decode time,pixels per element,ECC level,matrix size,quiet zone,symbol angle>
Default:	Disabled
Options:	0 = Disabled 1 = Enabled

Error Correction Level (Data Matrix Only)

Definition:	Outputs the Data Matrix ECC level. When enabled, the ECC level is appended to the symbol data.
Serial Cmd:	< K710 ,percent cell damage,total read time,capture time,locate time,decode time,pixels per element, ECC level ,matrix size,quiet zone,symbol angle>
Default:	Disabled
Options:	0 = Disabled 1 = Enabled

Matrix Size (Data Matrix Only)

Definition:	Defines the symbol matrix size, in number of pixels in both the x and y axis. When enabled, the matrix size value is appended to the symbol data.
Serial Cmd:	< K710 ,percent cell damage,total read time,capture time,locate time,decode time,pixels per element,ECC level, matrix size ,quiet zone,symbol angle>
Default:	Disabled
Options:	0 = Disabled 1 = Enabled

Quiet Zone (Data Matrix Only)

Definition: When this feature is enabled, the size of the quiet zone is evaluated and a PASS or FAIL message is appended to the symbol data.

Serial Cmd: <K710,percent cell damage,total read time,capture time,locate time,decode time,pixels per element,ECC level,matrix size,**quiet zone**,symbol angle>

Default: **Disabled**

Options: **0 = Disabled**
1 = Enabled

Symbol Angle (Data Matrix Only)

Definition: When this feature is enabled, the symbol orientation is appended to data output as a degree value representing the angle of the Data Matrix symbol's L-shaped finder pattern relative to the reader.

Serial Cmd: <K710,percent cell damage,total read time,capture time,locate time,decode time,pixels per element,ECC level,matrix size,quiet zone,**symbol angle**>

Default: **Disabled**

Options: **0 = Disabled**
1 = Enabled

9.6. ISO/IEC 15415 Symbol Quality Output

Symbol Quality Parameters for 2D Symbols Specified by ISO/IEC 15415

Supported Symbologies:

- Data Matrix ECC 200
- QR Code
- Micro QR Code

Minimum Resolution: 6.0 Pixels Per Element

Aperture

Definition: The size of aperture to use for grading configured as a percentage of the nominal narrow element width for the symbol under evaluation. For example, if you have a 15 mil symbol and you wish to grade using a 10 mil aperture you would configure the aperture to 67 % ($10/15 = 0.67$).

Serial Cmd: <**K725, aperture**, overall, contrast, modulation, reflectance margin, fixed pattern damage, axial non-uniformity, grid non-uniformity, unused ECC>

Default: 80 %

Options: Any number between 0 to 100 %

Overall

Definition: Overall is calculated in accordance with the ISO 15415 specification. The overall grade is the lowest individual parameter grade seen during the individual scan. When enabled, the Overall is attached to the symbol output data as a value.

Serial Cmd: <K725, aperture, overall, contrast, modulation, reflectance margin, fixed pattern damage, axial non-uniformity, grid non-uniformity, unused ECC>

Default: Disabled

Options: 0 = Disabled
1 = Enabled

Contrast

Definition: Contrast measurements assume 8-bit 0 to 255 grey correlate to 0 to 100% reflectance. Contrast is calculated in accordance with the ISO 15415 specification. The Contrast grading is defined as follows.

A (4.0) if $C \geq 70\%$
B (3.0) if $C \geq 55\%$
C (2.0) if $C \geq 40\%$
D (1.0) if $C \geq 20\%$
F (0.0) if $C \geq 20\%$

When enabled, the Contrast is attached to the symbol output data as a value.

Serial Cmd: <**K725**, aperture, overall, **contrast**, modulation, reflectance margin, fixed pattern damage, axial non-uniformity, grid non-uniformity, unused ECC>

Default: **Disabled**

Options: **0 = Disabled** 1 = Enabled

Modulation

- Definition: Modulation is calculated in accordance with the ISO 15415 specification. The Modulation grading is defined as follows.
- A (4.0) if $MOD \geq 0.50$
 - B (3.0) if $MOD \geq 0.40$
 - C (2.0) if $MOD \geq 0.30$
 - D (1.0) if $MOD \geq 0.20$
 - F (0.0) if $MOD \geq 0.20$
- When enabled, the Modulation is attached to the symbol output data as a value.
- Serial Cmd: <**K725**, aperture, overall, contrast, **modulation**, reflectance margin, fixed pattern damage, axial non-uniformity, grid non-uniformity, unused ECC>
- Default: **Disabled**
- Options: **0 = Disabled**
1 = Enabled

Reflectance Margin

- Definition: Reflectance Margin is calculated in accordance with the ISO 15415 specification. When enabled, the Reflectance Margin is attached to the symbol output data as a value.
- Serial Cmd: <**K725**, aperture, overall, contrast, modulation, **reflectance margin**, fixed pattern damage, axial non-uniformity, grid non-uniformity, unused ECC>
- Default: **Disabled**
- Options: **0 = Disabled**
1 = Enabled

Fixed Pattern Damage

- Definition: Fixed Pattern Damage is calculated in accordance with the ISO 15415 specification. When enabled, the Fixed Pattern Damage is attached to the symbol output data as a value.
- Serial Cmd: <**K725**, aperture, overall, contrast, modulation, reflectance margin, **fixed pattern damage**, axial non-uniformity, grid non-uniformity, unused ECC>
- Default: **Disabled**
- Options: **0 = Disabled**
1 = Enabled

Axial Non-Uniformity

Definition:	Axial Non-Uniformity is calculated in accordance with the ISO 15415 specification. The Axial Non-Uniformity grading is defined as follows. A (4.0) if $AN \leq 0.06$ B (3.0) if $AN \leq 0.08$ C (2.0) if $AN \leq 0.10$ D (1.0) if $AN \leq 0.12$ F (0.0) if $AN \leq 0.12$ When enabled, the Axial Non-Uniformity is attached to the symbol out- put data as a value.
Serial Cmd:	<K725, aperture, overall, contrast, modulation, reflectance margin, fixed pattern damage, axial non-uniformity, grid non-uniformity, unused ECC>
Default:	Disabled
Options:	0 = Disabled 1 = Enabled

Grid Non-Uniformity

Definition:	Grid Non-Uniformity is calculated in accordance with the ISO 15415 specification. The Grid Non-Uniformity grading is defined as follows. A (4.0) if $GN \leq 0.38$ B (3.0) if $GN \leq 0.50$ C (2.0) if $GN \leq 0.63$ D (1.0) if $GN \leq 0.75$ F (0.0) if $GN \leq 0.75$ When enabled, the Grid Non-Uniformity is attached to the symbol out- put data as a value.
Serial Cmd:	< K725 , aperture, overall, contrast, modulation, reflectance margin, fixed pattern damage, axial non-uniformity, grid non-uniformity , unused ECC>
Default:	Disabled
Options:	0 = Disabled 1 = Enabled

Unused ECC

Definition:	Unused ECC is calculated in accordance with the ISO 15415 specification. The Unused ECC grading is defined as follows. A (4.0) if $UEC \geq 0.62$ B (3.0) if $UEC \geq 0.50$ C (2.0) if $UEC \geq 0.37$ D (1.0) if $UEC \geq 0.25$ F (0.0) if $UEC \geq 0.25$ When enabled, the Unused ECC is attached to the symbol output data as a value.
Serial Cmd:	< K725 , aperture, overall, contrast, modulation, reflectance margin, fixed pattern damage, axial non-uniformity, grid non-uniformity, unused ECC >
Default:	Disabled
Options:	0 = Disabled 1 = Enabled

Grading Report

<VAL3>: Responds with a text report that summarized the grading of ISO/IEC15415.
This command will return the evaluation results, in a format similar to the one shown below.

15415 Validation Report			GRADE
ISO/IEC	Overall	= 0	F
15415:	Symbol Contrast	= 30	D
	Modulation	= 0	F
	Reflectance Margin	= 0	F
	Fixed Pattern Damage	= 50	C
	Axial Nonuniformity	= 100	A
	Grid Nonuniformity	= 100	A
	Unused ECC	= 45	A
	Aperture	= 80 %	C
SYMBOL			
DATA:	6000000006		
TYPE:	Datamatrix		

9.7. I SO/IEC 15416 Symbol Quality Output

Symbol Quality Parameters for Barcodes Specified by ISO/IEC 15416

Supported Symbologies:

- Code 128/GS1-128
- UPC-A/UPC-E/EAN-13/EAN-8
- Interleaved 2 of 5/ITF-14
- Code 39
- Code 93
- Codabar

Minimum Resolution: 4.0 Pixels Per Element

Aperture

Definition:	The size of aperture to use for grading configured as a percentage of the nominal narrow element width for the symbol under evaluation. For example, if you have a 13 mil UPC symbol and you wish to grade using a 6 mil aperture you would configure the aperture to 46% ($6/13 = 0.46$).
Serial Cmd:	<K726, aperture, overall, edge determination, decode, contrast, minimum reflectance, minimum edge contrast, modulation, defects, decod- ability, quiet zone>
Default:	40 %
Options:	Any number between 0 to 100%

Overall

Definition:	Overall is calculated in accordance with the ISO 15416 specification. The overall grade is the average of the individual scan grades applied to the symbol. The individual scan grades are the lowest individual parameter grade seen during the individual scan. These individual scan grades are not available for output. When enabled, the Overall is attached to the symbol output data as a value.
Serial Cmd:	<K726, aperture, overall, edge determination, decode, contrast, minimum reflectance, minimum edge contrast, modulation, defects, decod- ability, quiet zone>
Default:	Disabled
Options:	0 = Disabled 1 = Enabled

Edge Determination

- Definition: Edge Determination is calculated and graded for each scan and provided for the overall grade calculation in accordance with the ISO 15416 specification. The parameter grade and value provided for out-put is an average value for each measured scan over the entire symbol.
When enabled, the Edge Determination is attached to the symbol output data as a value.
- Serial Cmd: <K726, aperture, overall, edge determination, decode, contrast, minimum reflectance, minimum edge contrast, modulation, defects, - ability, quiet zone>

Decode

- Definition: Decode is calculated and graded for each scan and provided for the overall grade calculation in accordance with the ISO 15416 specification. The parameter grade and value provided for output is an average value for each measured scan over the entire symbol.
When enabled, the Decode is attached to the symbol output data as a value.
- Serial Cmd: <K726, aperture, overall, edge determination, **decode**, contrast, minimum reflectance, minimum edge contrast, modulation, defects, decodability, quiet zone>
- Default: **Disabled**
- Options: **0 = Disabled**
1 = Enabled

Contrast

- Definition: Contrast measurements assume 8-bit, 0 to 255 grey correlate to 0 to 100 % reflectance. Contrast is calculated and graded for each scan and provided for the overall grade calculation in accordance with the ISO 15416 specification. The parameter grade and value provided for out-put is an average value for each measured scan over the entire symbol.
When enabled, the Contrast is attached to the symbol output data as a value.
- Serial Cmd: **K726**, aperture, overall, edge determination, decode, **contrast**, minimum reflectance, minimum edge contrast, modulation, defects, decodability, quiet zone>
- Default: **Disabled**
- Options: **0 = Disabled**
1 = Enabled

Minimum Reflectance

Definition:	Minimum reflectance is calculated and graded for each scan and provided for the overall grade calculation in accordance with the ISO 15416 specification. The parameter grade and value provided for out- put is an average value for each measured scan over the entire symbol. When enabled, the Minimum Reflectance is attached to the symbol output data as a value.
Serial Cmd:	< K726 , aperture, overall, edge determination, decode, contrast, minimum reflectance , minimum edge contrast, modulation, defects, decodability, quiet zone>
Default:	Disabled
Options:	0 = Disabled 1 = Enabled

Minimum Edge Contrast

Definition:	Contrast measurement assume 8-bit 0 to 255 grey correlate 0 to 100 % reflectance The Minimum Edge Contrast is calculated and graded for each scan and provided for the overall grade calculation in accordance with the ISO 15416 specification. The parameter grade and value provided for output is an average value for each measured scan over the entire symbol. When enabled, the Minimum Edge Contrast is attached to the symbol output data as a value.
Serial Cmd:	< K726 , aperture, overall, edge determination, decode, contrast, minimum reflectance, minimum edge contrast , modulation, defects, decodability, quiet zone>
Default:	Disabled
Options:	0 = Disabled 1 = Enabled

Modulation

Definition:	Modulation is calculated and graded for each scan and provided for the overall grade calculation in accordance with the ISO 15416 specification. The parameter grade and value provided for output is an average value for each measured scan over the entire symbol. When enabled, the Modulation is attached to the symbol output data as a value.
Serial Cmd:	< K726 , aperture, overall, edge determination, decode, contrast, minimum reflectance, minimum edge contrast, modulation , defects, decodability, quiet zone>
Default:	Disabled
Options:	0 = Disabled 1 = Enabled

Defects

- Definition: Defects are calculated and graded for each scan and provided for the overall grade calculation in accordance with the ISO 15416 specification. The parameter grade and value provided for output is an average value for each measured scan over the entire symbol.
When enabled, the Defects are attached to the symbol output data as a value.
- Serial Cmd: <K726, aperture, overall, edge determination, decode, contrast, minimum reflectance, minimum edge contrast, modulation, **defects**, decodability, quiet zone>
- Default: **Disabled**
- Options: **0 = Disabled**
1 = Enabled

Decodability

- Definition: Decodability is calculated and graded for each scan and provided for the overall grade calculation in accordance with the ISO 15416 specification. The parameter grade and value provided for output is an average value for each measured scan over the entire symbol.
When enabled, the Decodability is attached to the symbol output data as a value.
- Serial Cmd: <K726, aperture, overall, edge determination, decode, contrast, minimum reflectance, minimum edge contrast, modulation, defects, **decodability**, quiet zone>
- Default: **Disabled**
- Options: **0 = Disabled**
1 = Enabled

Quiet Zone

- Definition: Quiet Zone is not an individually processed parameter within the ISO 15416 specification, but it is evaluated as a part of the ISO graded decode parameters feeding into the overall grade. Quiet Zone is provided here as average scan result where a passing scan receives an A/4.0 grade and a fail receives an F/0.0.
When enabled, the Quiet Zone is attached to the symbol output data as a value.
- Serial Cmd: <K726, aperture, overall, edge determination, decode, contrast, minimum reflectance, minimum edge contrast, modulation, defects, decodability, **quiet zone**>
- Default: **Disabled**
- Options: **0 = Disabled**
1 = Enabled

Grading Report

<VAL4>: Responds with a text report that summarized the grading of ISO/IEC15416. This command will return the evaluation results, in a format similar to the one shown below.

15416 Validation Report			GRADE
ISO/IEC	Overall	= 0	F
15416:	Edge Determination	= 0	F
	Decode	= 100	A
	Contrast	= 35	D
	Min Reflectance	= 100	A
	Min Edge Contrast	= 0	F
	Modulation	= 0	F
	Defects	= 100	A
	Decodability	= 1	F
	Quiz Zone	= 100	A
	Aperture	= 40 x	A
SYMBOL			
DATA:	code128		
TYPE:	Code128		

9.8. ISO/IEC 29158 Symbol Quality Output

Symbol Quality Parameters for direct part marking specified by ISO/IEC 29158 Supported Symbologies:

- DataMatrix ECC200

Minimum Resolution: 6.0 Pixels Per Element

Overall

Definition: The overall grade is the minimum grade of all evaluated parameters, noting minimum reflectance is not evaluated.
When enabled, the overall grade is attached to the symbol output data as a value.

Serial Cmd: <K727, **overall**, cell contrast, cell modulation, fixed pattern damage, axial non-uniformity, grid non-uniformity, unused ECC>

Default: **Disabled**

Options: **0 = Disabled**
1 = Enabled

Cell Contrast

Definition: Cell Contrast is calculated in accordance with the ISO 29158 specification. When enabled, the Cell Contrast is attached to the symbol output data as a value.

Serial Cmd: <K727, overall, **cell contrast**, cell modulation, fixed pattern damage, axial non-uniformity, grid non-uniformity, unused ECC>

Default: **Disabled**

Options: **0 = Disabled**
1 = Enabled

Cell Modulation

Definition: Cell Modulation is calculated in accordance with the ISO 29158 specification. Note the difference in the calculation for Cell Modulation versus Modulation in ISO 15415 eliminated the need for the parameter Reflectance Margin which was added to ISO 15415. When enabled, the Cell Modulation is attached to the symbol output data as a value.

Serial Cmd: <K727, overall, cell contrast, **cell modulation**, fixed pattern damage, axial non-uniformity, grid non-uniformity, unused ECC>

Default: **Disabled**

Options: **0 = Disabled**
1 = Enabled

Fixed Pattern Damage

- Definition: Fixed Pattern Damage is calculated in accordance with the ISO 29158 specification. When enabled, the Fixed Pattern Damage is attached to the symbol output data as a value.
- Serial Cmd: <K727, overall, cell contrast, cell modulation, **fixed pattern damage**, axial non-uniformity, grid non-uniformity, unused ECC>
- Default: **Disabled**
- Options: **0 = Disabled**
1 = Enabled

Axial Non-Uniformity

- Definition: Axial Non-Uniformity is calculated in accordance with the ISO 29158 specification. When enabled, the Axial Non-Uniformity is attached to the symbol out-put data as a value.
- Serial Cmd: <K727, overall, cell contrast, cell modulation, fixed pattern damage, **axial non-uniformity**, grid non-uniformity, unused ECC>
- Default: **Disabled**
- Options: **0 = Disabled**
1 = Enabled

Grid Non-Uniformity

- Definition: Grid Non-Uniformity is calculated in accordance with the ISO 29158 specification. When enabled, the Grid Non-Uniformity is attached to the symbol out-put data as a value.
- Serial Cmd: <K727, overall, cell contrast, cell modulation, fixed pattern damage, axial non-uniformity, **grid non-uniformity**, unused ECC>
- Default: **Disabled**
- Options: **0 = Disabled**
1 = Enabled

Unused ECC

- Definition: Unused ECC is calculated in accordance with the ISO 29158 specification. When enabled, the Unused ECC is attached to the symbol output data as a value.
- Serial Cmd: <K727, overall, cell contrast, cell modulation, fixed pattern damage, axial non-uniformity, grid non-uniformity, **unused ECC**>
- Default: **Disabled**
- Options: **0 = Disabled**
1 = Enabled

Grading Report

<VAL5>: Responds with a text report that summarized the grading of ISO/IEC29158.
This command will return the evaluation results, in a format similar to the one shown below.

29158 Validation Report			GRADE
ISO/IEC	Overall	= 75	B
29158:	Cell Contrast	= 100	A
	Cell Modulation	= 75	B
	Fixed Pattern Damage	= 100	A
	Axial Nonuniformity	= 100	A
	Grid Nonuniformity	= 100	A
	Unused ECC	= 100	A
SYMBOL			
DATA:	6000000006		
TYPE:	Datanatrix		

10. Matchcode

This section explains the matchcode output functions and the master symbol database setup.

Matchcode Serial Commands	195
Overview of Matchcode	195
Matchcode Type	196
Sequence Step Interval	200
Match Replace	200
Mismatch Replace	201
New Master Pin	202

10.1. Matchcode Serial Commands

Matchcode	<K223,matchcode type,sequential matching,match start position,match length,wildcard character, sequence on No-Read,sequence on mismatch>
Number of Master Symbols	<K224,number of master symbols>
New Master Pin	<K225,status>
Sequence Step Interval	<K228,sequence step interval>
Master Symbol Data	<K231,index,master symbol data>
Match Replace	<K735,status,match replacement string>
Mismatch Replace	<K736,status,mismatch replacement string>

10.2. Overview of Matchcode

Definition: **Matchcode** allows the user to store master symbol data in the reader's memory, compare that data against other symbol data, and define how symbol data and/or discrete signal output will be directed.
A master symbol database can be set up for up to 10 master symbols.

NOTE!



Matchcode will function with multiple symbols; however, if **Matchcode Type** is set to **Sequential** or if **Triggering Mode** is set to **Continuous Read 1 Output**, the reader will behave as if **Number of Symbols** were set to **1**, regardless of the user-defined configuration.

Usage: Matchcode is used in applications to sort, route, or verify data based on matching the specific symbol in a variety of ways as defined in this section. For example, a manufacturer might sort a product based on dates that are embedded in the symbol.

Steps for Entering and Using Master Symbols

- 1 Set **Triggering Mode** to **External** or **Serial**.
- 2 Choose the method of symbol comparison that fits your application.
- 3 Define the output you want to achieve with your matchcode setup:
 - (a) **Symbol data output**
 - (b) **Discrete output**
- 4 Select the number of master symbols you want to create.
- 5 Decide which way you want to enter your master symbol(s):
 - (a) **Send a serial command with symbol data in the form of <M231,master symbol#, data>.**
 - (b) **Send a <G> (Read Next Symbol as Master Symbol) command.**
 - (c) **Enable the New Master Pin command and activate the discrete input to store the next symbol read as the master symbol.**

10.3. Matchcode Type

Definition: Allows the user to choose the way that master symbols will be compared with subsequently read symbols.



NOTE!

First set **Triggering Mode** to **External** or **Serial**.

Serial Cmd: <K223,matchcode type,sequential matching,match start position, match length,wild card character,sequence on No-Read,sequence on mismatch>

Default: **Disabled**

Options: **0 = Disabled**
1 = Enabled
2 = Wild Card
3 = Sequential

Disabled: Has no effect on operations.

Enabled: Instructs the reader to compare symbols or portions of symbols with the master symbol.

Wild Card: Allows the user to enter user-defined wild card characters in the master symbol.

Sequential: Instructs the reader to sequence after each match (numeric only) and compare symbols or portions of symbols for sequential numbers.



NOTE!

If **Matchcode Type** is set to **Sequential**, the reader will behave as if **Number of Symbols** were set to **1**, regardless of the user-defined configuration.

Sequential Matching

Usage: Useful in tracking product serial numbers that increment or decrement sequentially.

Definition: With Sequential enabled, Sequential Matching determines if a count is in ascending (incremental) or descending (decremental) order.

Serial Cmd: <K223,matchcode type,sequential matching,match start position,match length,wild card character,sequence on No-Read,sequence on mismatch>

Default: **Increment**

Options: **0 = Increment**
1 = Decrement

Match Start Position

Usage:	Match Start Position is useful in defining specific portions of a symbol for comparison. For example, if a symbol contains a part number, manufacturing date, and lot code info, but you are only interested in the part number information, you can set the reader to sort only the part number and ignore the other characters.
Definition:	Match Start Position determines the portions of symbols that will be matched by defining the first character in the symbol (from left to right) that will be compared with those of the master symbol, when Matchcode Type is set to Enabled or Sequential.
Function:	For example, if Match Start Position is set to 3, the first 2 characters read in the symbol will be ignored and only the 3rd and subsequent characters to the right will be compared, up to the number of characters specified by Match Length .
Serial Cmd:	< K223 ,matchcode type,sequential matching, match start position , match length,wild card character,sequence on No-Read,sequence on mismatch>
Default:	0
Options:	0 to 3000



NOTE!

Match Start Position must be set to 1 or greater to enable this feature. A 0 setting will disable this feature.

Match Length

Usage:	Example: If Match Length is set to 6 in a 10-character symbol, and Match Start Position is set to 2, only the 2nd through 7th characters (from left to right) will be compared.
Definition:	Defines the length of the character string that will be compared with that of the master symbol when Match Start Position is set to 1 or greater. When Match Start Position is set to 0, no comparison will occur.
Serial Cmd:	< K223 ,matchcode type,sequential matching,match start position, match length ,wild card character,sequence on No-Read,sequence on mismatch>
Default:	1
Options:	1 to 3000

Wild Card Character

Usage:	Example: With Wild Card Character defined as the default asterisk, defining CR*34 as the master symbol will result in matches for CR134 and CR234, but not CR2345. Entering URGENT** as your master symbol will result in matches for URGENT, URGENT1, and URGENT12 but not for URGENT123. This means any wild cards appended to the master symbol data will result in matches of symbols in variable lengths up to the master symbol lengths but not over. However, wild cards in the beginning or center of a symbol (e.g., UR**NT) do not allow for variable symbol lengths.
Definition:	Wild Card Character allows a user to define a wild card character as part of the master symbol.
Serial Cmd:	< K223 ,matchcode type,sequential matching,match start position,match length, wild card character ,sequence on No-Read,sequence on mismatch>
Default:	* (asterisk)
Options:	Any ASCII character.

Sequence on No-Read

- Usage: **Sequence on No-Read** is useful when the reader needs to stay in sequence even if no decode occurs.
- Definition: When **Sequence on No-Read** is **Enabled** and **Matchcode** is set to **Sequential**, the reader sequences the master symbol on every match or No-Read. When disabled, it does not sequence on a No-Read.
- Serial Cmd: <**K223**,matchcode type,sequential matching,match start position,match length,wild card character,**sequence on No-Read**,sequence on mismatch>
- Default: **Enabled**
- Options: 0 = Disabled
1 = **Enabled**

As an example of **Sequence on No-Read Enabled**, consider the following decodes:

Master Symbol	Decoded Symbol	Master Symbol after Decode
001	001	002
002	002	003
003	No-Read	004 (sequenced on No-Read)
004	004	005
005	No-Read	006 (sequenced on No-Read)
006	No-Read	007 (sequenced on No-Read)
007	007	008

As an example of **Sequence on No-Read Disabled**, consider the following series of decodes:

Master Symbol	Decoded Symbol	Master Symbol after Decode
001	001	002
002	002	003
003	No-Read	003 (not sequenced)
003	003	004
004	No-Read	004 (not sequenced)
004	No-Read	004 (not sequenced)
004	004	005

Sequence on Mismatch



NOTE!

Matchcode must be set to **Sequential** for this command to function.

- Usage: Enable this parameter if every trigger event should have a decode and more than one consecutive mismatch may occur.
Disable this parameter if every trigger event should have a decode but no more than one consecutive mismatch may occur.
- Definition: When set to Enabled, the master symbol sequences on every decode, match, or mismatch. When set to Disabled, the master symbol will not sequence whenever consecutive mismatches occur.
- Serial Cmd: <K223,matchcode type,sequential matching,match start position,match length,wild card character,sequence on No-Read,**sequence on mismatch**>
- Default: **Disabled**
- Options: **0 = Disabled**
1 = Enabled

The reader will sequence the master to one more or one less than the decoded symbol.

As an example of **Sequence on Mismatch Enabled**, consider the following decodes:

Master Symbol	Decoded Symbol	Master Symbol after Decode
001	001	002
002	002	003
003	abc	004 (sequenced on mismatch)
004	004	005
005	def	006 (sequenced on mismatch)
006	ghi	007 (sequenced on mismatch)
007	007	008

As an example of **Sequence on Mismatch Disabled**, consider the following decodes:

Master Symbol	Decoded Symbol	Master Symbol after Decode
001	001	002
002	002	003
003	abc	004 (sequenced because of previous match)
004	004	005
005	def	006 (sequenced because of previous match)
006	ghi	006 (not sequenced)
006	006	007

10.4. Sequence Step Interval

- Usage: Useful in applications in which it is desirable to count by intervals other than 1.
- Definition: Sequencing in Matchcode operations can occur in steps from 1 to 32,768. Sequencing performs like a mechanical counter by displaying positive integers and a specific number of digits after roll-overs.
For example, $000 - 3 = 997$ (not -3) and $999 + 3 = 002$ (not 1002).
- Serial Cmd: **<K228,sequence step interval>**
- Default: **1**
- Options: Any number from 1 to 32768
- Example: If Sequence Step is set to 3 and Sequential Matching is set to Increment:

Master Symbol	Decoded Symbol	Master Symbol after Decode
003	001	003
003	002	003
003	003	006
006	004	006
006	005	006
006	006	009
004	004	005

10.5. Match Replace

- Usage: Provides a convenient shortcut for applications that need to output a predefined text string whenever a symbol matches a master symbol.
- Definition: Outputs a user-defined data string whenever a match occurs and **Matchcode** is enabled.
- Serial Cmd: **<K735,status,replacement string>**
- Default: **Disabled**
- Options: **0 = Disabled**
1 = Enabled

Replacement String

- Definition: User-defined data string that, when enabled, replaces symbol data whenever a match occurs.
- Serial Cmd: **<K735,status,replacement string>**
- Default: **MATCH**
- Options: An ASCII string up to 64 characters.

10.6. Mismatch Replace

Usage:	Provides a convenient shortcut for applications that need to output a predefined text string whenever a symbol does not match a master symbol.
Definition:	Outputs a user-defined data string whenever a mismatch occurs and Matchcode is enabled.
Serial Cmd:	< K736,status ,replacement string>
Default:	Disabled
Options:	0 = Disabled 1 = Enabled

Replacement String

Definition:	User-defined data string that, when enabled, replaces symbol data whenever a mismatch occurs.
Serial Cmd:	< K736,status,replacement string >
Default:	MISMATCH
Options:	An ASCII string up to 64 characters.

10.7. New Master Pin

Definition: If **Matchcode** and **New Master Pin** are enabled and the new master pin is momentarily activated (must be active for a minimum of 10 ms) master symbol information will be loaded into the database based on the next read cycle that achieves a Good Read, starting with **Index 1**.



NOTE!

For the C5PC, Input 1 (pin 3) is Default and Input 2 (pin 4) is New Master.

Serial Cmd: <K225,status>
Default: **Disabled**
Options: **0 = Disabled**
 1 = Enabled

New Master Load Status

Definition: The new master status responds with the number of the next master position to be loaded, where 0 represents "idle" or "no master to be loaded."

Example: If the user has the **Number of Master Symbols** set to **1**, and then either sends a <G> or toggles an active **New Master Pin**, the state will be **1**, and prior to reading and effectively loading position **1**, the response to <NEWM> would be <NEWM/1>. Once a symbol has been read and loaded, the status will be cleared: <NEWM/0>.

Serial Cmd: <NEWM>

11. Camera and IP Setup

This section provides adjustment parameters for the physical controls of the camera, image acquisition, data-base settings, and image diagnostics.

Camera and IP Setup Serial Commands	204
Window of Interest	205
Pixel Binning	207
Camera Settings	207
White Balance Settings (QSXGA Color Only)	208
Color Filter	209
Focus Setup	210
Illumination Brightness	211
Morphological Pre-Processing	213
Morphological Operation and Operator Size	213
Damaged Symbol	215
Linear Security Level	215
Advanced Decoding Parameters	216

11.1. Camera and IP Setup Serial Commands

Window of Interest	<K516,row pointer,column pointer,row depth,column width>
Damaged Symbol	<K519,damaged symbol status>
Focus Setup	<K525,focal distance,distance units,focus mode,-no-read limit>
Illumination Brightness	<K536,brightness,light source,fixed light on time,fixed light on delay time>
Camera Settings	<K541,exposure,gain>
Pixel Binning	<K542,pixel binning status>
Color Filter	<K543,color filter>
White Balance	<K544,red gain,green gain,blue gain>
Morphological Pre-Processing	<K550,status>
Morphological Operation	<K551,morphological operation,operator size>
Set License	<K556,license file name,license key>
Linear Security Level	<K560,linear security level>
Fast Linear Mode	<K562,Fast Linear Mode>
Curved 2D	<K563,Curved 2D>
Shift-JIS to UTF-8	<K564,Shift-JIS to UTF-8>
1D Quiet Zone Violation	<K565,1D Quiet Zone Violation>
Scale Image	<K566,Scale Image>
2D Damaged Mode	<K567,2D Damaged Mode>
Attempt Morphology Manipulation	<K568,Attempt Morphology Manipulation>

11.2. Window of Interest

The active pixel area of the image sensor is called the **Window of Interest (WOI)**. The WOI allows the user to select an area of the field of view in which the desired symbol is located.

The programmable window of interest increases decode speed, improves threshold, and makes it easy to select specific symbols from among several in the field of view. The user provides the upper-left pixel location and the size of the window in rows and columns to define the Window of Interest.

Window of Interest by Serial Command

The figure shows where to locate the start position of the row and column pointers and how to measure the column depth and row width dimensions.

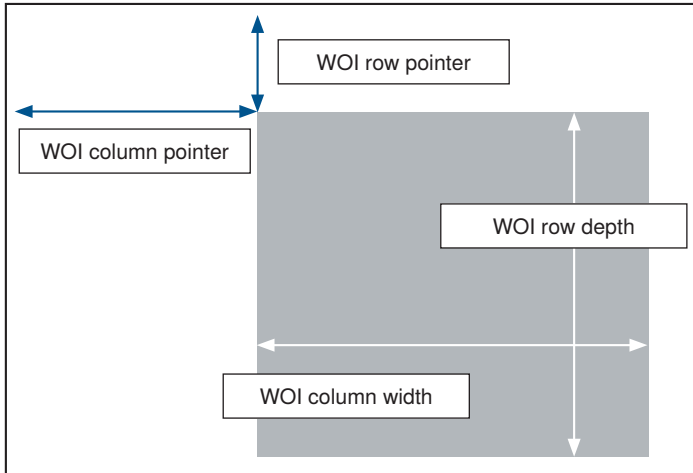

• Row Pointer

Definition:

Defines the row position of the upper-left starting point of the image window.

Serial Cmd:

<K516,row pointer,column pointer,row depth,column width>

Default:

All models: 0

Options:

QSXGA : 0 to (1944 – row depth)

SXGA : 0 to (960 – row depth)

WVGA : 0 to (480 – row depth)

• Column Pointer

Definition: Defines the column position of the upper-left starting point of the image window.
Serial Cmd: <K516,row pointer,**column pointer**,row depth,column width>
Default: **All models: 0**
Options: **QSXGA:** 0 to (2592 – column width)
SXGA: 0 to (1280 – column width)
WVGA: 0 to (752 – column width)

• Row Depth

Definition: Defines the size, in rows, of the image window. Maximum value is defined as the maximum row size of the image sensor minus the Row Pointer value.
Serial Cmd: <K516,row pointer,column pointer,**row depth**,column width>
Default: **QSXGA: 1944**
SXGA: 960
WVGA: 480
Options: **QSXGA:** 3 to (1944 – row pointer)
SXGA: 3 to (960 – row pointer)
WVGA: 3 to (480 – row pointer)

• Column Width

Definition: Defines the size, in columns, of the image window. Maximum value is defined as the maximum column size of the image sensor minus the Column Pointer value.
Serial Cmd: <K516,row pointer,column pointer,row depth,**column width**>
Default: **QSXGA: 2592**
SXGA: 1280
WVGA: 752
Options: **QSXGA:** 8 to (2592 – column pointer)
SXGA: 8 to (1280 – column pointer)
WVGA: 8 to (752 – column pointer)

• Important Notes

- The column width value must be a modulus 8 value. Regardless of the column width setting that is configured, the actual column width will be decreased if necessary to a modulus 8 value. For example, a column width value of **639** would actually be **632**. A user query for the value of this setting would still return **639**.
- The column pointer must be an even value. Regardless of the column pointer setting that is configured, the actual column pointer will be decreased if necessary to an even value. For example, a column pointer value of **101** would actually be **100**. A user query for the value of this setting would still return **101**.

11.3. Pixel Binning

Definition: In addition to windowing the image sensor, smaller resolutions can be obtained by down sampling the entire captured image by using pixel binning. Pixel binning can increase the signal to noise ratio and produce a more pleasing output image with reduced artifacts. It will also improve low-light performance. It is important to note that enabling pixel binning does not affect the sensor frame rate as the pixels still need to be processed in order to be averaged and binned.

Usage: <K542,pixel binning>

Default: **Disabled**

Options: **0 = Disabled** 1 = Enabled

- **Disabled**

Pixel-binning is disabled.

- **Enabled**

Two column pixels and two row pixels are averaged to create a single pixel value providing a 2:1 reduction in the vertical pixels and a 2:1 reduction in the horizontal pixels for a combined 4:1 reduction. An image with a dimension of 640 x 480 will be scaled to 320 x 240.

11.4. Camera Settings

Camera Settings are typically obtained during the calibration process, and do not necessarily need to be modified directly by the user.

QSXGA, SXGA, and WVGA

- **Exposure**

Usage: Faster exposures reduce blurring in faster applications. Slower exposures are useful in slower applications and lower contrast applications.

Definition: This value sets the exposure or integration time (in micro-seconds) for the image sensor pixels. The exposure setting in relation to the speed of the object is critical. If an object is moving rapidly and too long an exposure value is selected, blurring or smearing of the object will occur. As exposure time is decreased the movement of the object becomes less of a factor but, with the duration of light collection by the pixels reduced, the image sensor gain will need to be increased to compensate.

Serial Cmd: <K541,exposure,gain>

Default: **All versions: 2,500 µs**

Options: Any number between 50 – 100,000



NOTE!

The Exposure parameter is read-only when the reader is in **Continuous Read Auto Trigger Mode**.

- **Gain**
Usage: Can be used to adjust the brightness of the image.
Definition: Sets the gain value for the image sensor and is a percentage value from 0 (lowest gain) to 100 % (highest gain). This setting can be configured through auto-calibration. A higher gain value will increase the brightness of the image, but the noise performance of the system will be reduced. Before configuring the gain, the required exposure should be set, and the gain should be configured to optimize the exposure setting.
Serial Cmd: <K541,exposure,gain>
Default: **QSXGA: 33 %**
SXGA: 0 %
WVGA: 33 %
Options: Any number between 0 – 100, representing 0 % to 100 %

Important: There are 4 levels of Gain in SXGA readers. Each level corresponds to 25 percentage points.

- Level 1 = 0 to 24 %
- Level 2 = 25 to 49 %
- Level 3 = 50 to 74 %
- Level 4 = 75 to 100 %

11.5. White Balance Settings (QSXGA Color Only)

- Definition: <K544,red gain,green gain,blue gain>
- Default: **Factory-Calibrated**
- Options: Any number between 0 – 100

Red Gain

Sets the gain value for the red color channel of the image sensor and is a percentage value from 0 % (lowest gain) to 100 % (highest gain). The color channel parameters are used to avoid unrealistic colors so that objects that appear white to the human eye are rendered white in the final image. The default value for this parameter is factory-calibrated.

Green Gain

Sets the gain value for the green color channel of the image sensor and is a percentage value from 0 % (lowest gain) to 100 % (highest gain). The color channel parameters are used to avoid unrealistic colors so that objects that appear white to the human eye are rendered white in the final image. The default value for this parameter is factory-calibrated.

Blue Gain

Sets the gain value for the blue color channel of the image sensor and is a percentage value from 0 % (lowest gain) to 100 % (highest gain). The color channel parameters are used to avoid unrealistic colors so that objects that appear white to the human eye are rendered white in the final image. The default value for this parameter is factory-calibrated.

11.6. Color Filter

Definition:	If you are using a 5 megapixel color C5PC series, this filter captures an image in color. To process the image for symbol decoding, the image must be filtered or the R, G, and B cells need to be equalized. This can be done by applying one of the filters available or by performing a white balance with the current camera configuration before trying to decode a symbol. This option specifies the filter method that is applied to the RGB color image to produce a monochrome image.
Usage:	<K543,color filter>
Default:	Green Interpolate
Options:	0 = Disabled (Raw, No Filter) 1 = Enabled 2 = Horizontal 1D Symbols 3 = Green Interpolate

Disable

No filter is applied to image. If you are attempting to read symbols with no filter applied, a white balance should be performed first to balance the red, blue, and green cells of the image sensor.

Enabled (General Purpose)

This is a general purpose filter that is applied to the RGB image to provide a grayscale image that can be used for most applications.

This filter should be used when reading 2D symbols, 1D symbols that are not positioned horizontally in the field of view, or a combination of 1D and 2D symbols.

Horizontal 1D Symbols

This filter is applied to the RGB image to provide a grayscale image that is specifically designed to provide the best suitable image for a horizontally-positioned 1D symbol.

This filter should be used when reading 1D symbols that are positioned horizontally across the field of view.

Green Interpolate

This filter is applied to the RGB image to provide a grayscale image for decoding similar to a luminance calculation. Unlike a luminance calculation, Green Interpolate provides an image 1:1 resolution to the input image. This filter provides better omni-directional symbol decode performance. Like Horizontal 1D Symbols, and unlike General Purpose, a white balance is not necessary.

This filter is recommended for most decoding applications that can afford extra processing time.



NOTE!

For high-resolution 1D symbols that are positioned horizontally, the Horizontal 1D Symbols filter is preferable.

11.7. Focus Setup

Focal Distance

Definition: Provides the focal distance adjustment for the camera. Any value outside this range will be rejected. If you attempt to set the Focal distance as the out of range value of your model, the parameter will be left as-is.

Serial Cmd: <K525,focal distance,distance units,focus mode,no-read limit>

Default: 102

Options: 25 to 4,000 (mm)
100 to 4,000 (1/100 inch)

Distance Units

Definition: Defines the measurement unit value of the **Focal Distance** parameter.

Serial Cmd: <K525,focal distance,distance units,focus mode,no-read limit>

Default: **Millimeters**

Options: 0 = **Millimeters**
1 = 1/100 inch

For example, the following are valid configurations to set the Focal Distance to three distances:

Required Focal Distance	Distance Units = mm (0)	Distance Units = 1/100 in. (1)
2 inch, or 50 mm	<K525,50,0>	<K525,200,1>
3 inch, or 76 mm	<K525,76,0>	<K525,300,1>
6 inch, or 152 mm	<K525,152,0>	<K525,600,1>

Focus Mode

Definition: This field set to **1** enables the autofocus mode to be enabled. The read cycle must also be a **Continuous Read** mode or **Continuous Read Auto** (Auto Photometry) mode. Autofocus mode does not apply to triggered read cycles. If the value is set to 0, only the distance value is used.

Serial Cmd: <K525,focal distance,distance units,focus mode,no-read limit>

Default: **No-Read Autofocus**

Options: 0 = User Value Only
1 = **No-Read Autofocus**

No-Read Limit

Definition: This is the number of no-reads that are encountered consecutively in a **Continuous Read** mode to trigger an **Autofocus** pass.

Serial Cmd: <K525,focal distance,distance units,focus mode,no-read limit>

Default: 5

Options: 1 to 255

11.8. Illumination Brightness

Definition: This feature allows you to adjust the brightness of the illumination LEDs. Since the reader has control over the brightness of the illumination, it can provide consistent brightness output between readers through a factory calibration operation. Each of the brightness settings is calibrated to provide the same level of intensity for each reader.

Serial Cmd: <K536,brightness,light source,fixed light on time,fixed light on delay time>

Default: **High**

Options: 0 = Off 1 = Low
2 = Medium
3 = High
4 = Constant
5 = Extreme

• Constant

When set to **Constant**, the illumination brightness is the same power level as the **High** setting. However, the LEDs will always be on during a read cycle and will only be off between read cycles. This cuts down on perceptible LED flashing.

• Extreme

When set to **Extreme**, **illumination brightness** enters Power Strobe mode. In this mode, illumination is extremely intense, and can only be activated for a maximum of 1 ms.

Light Source

Definition: The setting allows the user to change the illumination light source.

Cmd: <K536,brightness,light source,fixed light on time,fixed light on delay time>

Default: **Outer LED Only**

Options: 0 = External Strobe
1 = Inner White LED Only
2 = Inner Red LED Only
3 = Outer LED Only

• External Strobe

For **Configurable Output 3 (K812)**, **Output On, Use as External Illumination Strobe** to function, **Light Source** must be set to **External Strobe**.

Fixed Light ON Time



NOTE!

Fixed Light ON Time only functions when **Power Strobe** mode and **External Strobe** are enabled.



NOTE!

Entering 0 will disable Fixed Light ON Time, and will override it to **1 ms** if **Illumination Brightness** is set to Extreme.

Definition: **Fixed Light ON Time** allows you to control **how long** illumination will be **ON** when the camera captures an image. This command functions along with **Fixed Light ON Delay Time** to allow you to vary the amount of time an object appears in an image capture, assuming the capture environment is dark.

Serial Cmd: <K536,brightness,light source,fixed light on time,fixed light on delay time>
Options: 0 – 100,000 μ s
Default: **0 (Disabled)**

Fixed Light ON Delay Time



NOTE!

Fixed Light ON Delay Time only functions when **Power Strobe** mode and **External Strobe** are enabled.

Definition: **Fixed Light ON Delay Time** allows you to control **when** illumination will be **ON** during an image capture. This command functions along with **Fixed Light ON Time** to allow you to vary **the time at which** an object appears in an image capture, assuming the capture environment is dark.

Example of Fixed Light ON Time and Fixed Light ON Delay Time in Power Strobe Mode:
Preconditions: The moving target object will show up 20 μ s after capture starts. A 100 μ s exposure will be able to freeze a moving object in the captured image.
Setup: Power Strobe with Fixed Light ON Time set to 100 μ s and Fixed Light ON Delay Time set to 20 μ s with exposure set to 120 μ s.

Example of Fixed Light ON Time and Fixed Light ON Delay Time in External Strobe Mode:
Preconditions: The time delay between the strobe signal on the reader's Output 3 and the moment the external illuminator turns ON is 50 μ s.
A 100 μ s exposure will be able to freeze a moving object in the captured image.
Setup: External Strobe with Fixed Light ON Time set to 50 μ s and Fixed Light ON Delay Time set to 100 μ s with exposure set to 150 μ s.

Serial Cmd: <K536,brightness,light source,fixed light on time,fixed light on delay time>
Options: 0 – 100,000 μ s
Default: **0**

11.9. Morphological Pre-Processing

Morphological Pre-Processing allows you to select the method for processing images, and to choose the operator size for that method.

Important: This command must be set to **Enabled** for **Morphological Operation** to function.

Serial Cmd: <K550,morphological pre-processing>
Default: **Disabled**
Options: **0 = Disabled** 1 = Enabled

11.10. Morphological Operation and Operator Size

Morphological Operation

Definition: **Morphological Operation** allows the user to select the method for processing captured images.

Serial Cmd: <K551,0,morphological operation,operator size>

Default: **Grow Dark**

Options: **0 = Grow Dark**
1 = Shrink Dark
2 = Connect Dark
3 = Separate Dark

• Erode (Grow Dark)

Erode increases the dark cell size of a symbol. Useful for increasing the dark cell size of a dark-on-light Data Matrix symbol.

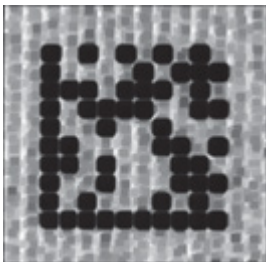

- **Dilate (Shrink Dark)**

Dilate increases the light cell size of a symbol. Useful for increasing the light cell size of a light-on-dark Data Matrix symbol.

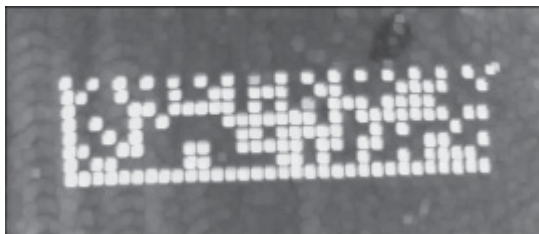

- **Open (Connect Dark)**

Open removes minor light defects of dark cells by performing a **Dilate** function followed by an **Erode** function.

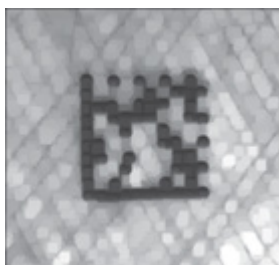

- **Close (Separate Dark)**

Close removed minor dark defects of light cells by performing an **Erode** function followed by a Dilate function.

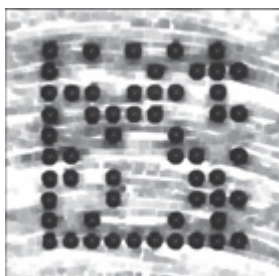

Operator Size

Definition: **Operator Size** determines the size of the area or "pixel neighborhood" (measured in pixels) in which the morphological operation is being performed.

Serial Cmd: <K551,0,morphological operation,**operator size**>

Default: **Small**

Options: **3 = Small (3 pixels by 3 pixels)**
5 = Medium (5 pixels by 5 pixels)
7 = Large (7 pixels by 7 pixels)

11.11. Damaged Symbol

Definition: When **Damaged Symbol** is enabled, the reader will make additional attempts to decode damaged Code 128 and Code 39 symbols. It is effective on symbols with high noise and partial bar missing. Enabling Damaged Symbol may significantly increase decode time.

Serial Cmd: <K519,damaged symbol status>

Default: **Disabled**

Options: **0 = Disabled**
1 = Enabled

11.12. Linear Security Level

Definition: **Linear Security Level** is intended to prevent misreads. When it is set to a higher level, it requires more scan lines to decode the same result, making it more secure.

Serial Cmd: <K560,linear security level>

Default: **Aggressive**

Options: **0 = Aggressive**
1 = Normal
2 = Secure

11.13. Advanced Decoding Parameters

Definition: **Advanced Decoding Parameters** can help you read difficult and damaged symbols, and are optimized for direct part marks (DPM).

Serial Cmd: <**K562**,Fast Linear Mode>
<**K563**,Curved 2D>
<**K564**,Shift-JIS to UTF-8>
<**K565**,Linear Quiet Zone Violation>
<**K566**,Scale Image>
<**K567**,2D Damaged Mode>
<**K568**,Attempt Morphology Manipulation>

12. Configuration Database

This section concerns the various capture settings and processing settings that can be used to fine-tune the reader's performance in your application.

- Introduction 218
- Configuration Database Serial Commands 218
- Number of Active Indexes 219
- Configuration Database Status 219
- Database Mode 225
- Save Current Settings to Configuration Database 228
- Load Current Settings from Configuration Database 228
- Request Selected Index Settings 228
- Request All Configuration Database Settings 229

12.1. Introduction

For the Configuration Database, the following functions as the bank switching function are possible to achieve.

- Up to ten settings can be held.
- Settable parameters: Exposure, Gain, Focal Distance, Pixel Binning, Window of Interest/Region of Interest, Symbology, Morphology Operator, and Morphology Size.
- Switch command of the database: <K255-,index>
- Automatic switching function of the database: <K252,number of active indexes>

12.2. Configuration Database Serial Commands

Number of Active Indexes	<K252,number of active indexes,sort database>
Configuration Database Status	<K255,index,exposure,gain,focal distance,pixel binning,row pointer,column pointer,row depth,column width,symbology,morphology operator,morphology size>
Save Current Settings to Database	<K255+,index>
Load Current Settings from Database	<K255-,index>
Request Selected Index Settings	<K255?,index>
Request All Database Settings	<K255?>
Database Mode	<K256,switch mode,frame count/time,image process looping,image dimensions>

12.3. Number of Active Indexes

Usage:	Useful for applications that require several different complex reader configurations to be applied sequentially. Multiple database indexes allow you to concatenate configuration profiles, and to perform more complex operations than would be possible with only one set of configuration parameters.
Definition:	This feature allows you to set the number of database records (groups of settings) that will be used automatically during the read cycle. If Number of Active Indexes is set to 0, only the current reader settings will be used, not database entry settings.
Serial Cmd:	<K252,number of active indexes,sort database>
Default:	0 (Disabled)
Options:	0 to 10

Sort Database

Definition:	Sort Database moves the database entry that produced a successful decode to the first position in the list of database entries.
Serial Cmd:	<K252,number of active indexes,sort database>
Default:	Disabled
Options:	0 = Disabled 1 = Enabled

12.4. Configuration Database Status

Index

Usage:	Useful for applications that require several different complex reader configurations to be applied sequentially. Multiple database indexes allow you to concatenate configuration profiles, and to perform more complex operations than would be possible with only one set of configuration parameters.
Definition:	Determines the specific database index that will be used.
Serial Cmd:	<K255,index,exposure,gain,focal distance,pixel binning,row pointer,column pointer, row depth,column width,symbology,morphology operator,morphology size>L
Options:	1 to 10

Exposure

Serial Cmd:	<K255,index, exposure ,gain,focal distance,pixel binning,row pointer,column pointer,row depth,column width,symbology,morphology operator,morphology size>
Default:	2500
Options:	50 to 100,000



NOTE!

The Exposure parameter is read-only when the reader is in **Continuous Read** mode.

Gain

Serial Cmd: <**K255**,index,exposure,**gain**,focal distance,pixel binning,row pointer,column pointer, row depth,column width,symbology,morphology operator,morphology size>
Default: **0**
Options: 0 to 100

Focal Distance

Definition: Provides the focal distance adjustment for the camera.
Any value outside this range will be rejected.
If you attempt to set the Focal distance as the out of range value of your model, the parameter will be left as-is.

Serial Cmd: <**K255**,index,exposure,**gain**,**focal distance**,pixel binning,row pointer,column pointer,row depth,column width,symbology,morphology operator,morphology size>
Default: **102**
Options: 25 to 4,000 (mm)
100 to 4,000 (1/100 inch)

Pixel Binning

Serial Cmd: <**K255**,index,exposure,**gain**,focal distance,**pixel binning**,row pointer,column pointer,row depth,column width,symbology,morphology operator,morphology size>
Default: **Disabled**
Options: **0 = Disabled** 1 = Enabled

Important: Pixel Binning has no effect when the **Image Dimension** mode is configured as **Region of Interest** in the **Data-base Mode** command. This is because the **Window of Interest** camera settings are determined by the software based on the **Region of Interest** setup. There is no benefit to Pixel Binning to increase processing speed when ROI is configured, because the frame size would need to be increased to make Pixel Binning possible.

Row Pointer

Definition: The image dimension settings can be applied as a Window of Interest or a Region of Interest, depending on the image dimension mode selected in the **Database Mode** command.

Serial Cmd: <**K255**,index,exposure,**gain**,focal distance,pixel binning,**row pointer**,column pointer,row depth,column width,symbology,morphology operator,morphology size>
Default: **All models: 0**
Options: **QSXGA:** 0 to (1944 – row depth)
SXGA: 0 to (960 – row depth)
WVGA: 0 to (480 – row depth)

Column Pointer

- Definition: The image dimension settings can be applied as a Window of Interest or a Region of Interest, depending on the image dimension mode selected in the **Database Mode** command.
- Serial Cmd: <**K255**,index,exposure,gain,focal distance,pixel binning,row pointer,**column pointer**,row depth,column width,ymbology,morphology operator,morphology size>
- Default: **All models: 0**
- Options: **QSXGA**: 0 to (2592 – column width)
SXGA: 0 to (1280 – column width)
WVGA: 0 to (752 – column width)

Row Depth

- Definition: The image dimension settings can be applied as a Window of Interest or a Region of Interest, depending on the image dimension mode selected in the **Database Mode** command.
- Serial Cmd: <**K255**,index,exposure,gain,focal distance,pixel binning,row pointer,column pointer,**row depth**,column width,ymbology,morphology operator,morphology size>
- Default: **QSXGA: 1944**
SXGA: 960
WVGA: 480
- Options: **QSXGA**: 3 to (1944 – row pointer)
SXGA: 3 to (960 – row pointer)
WVGA: 3 to (480 – row pointer)

Column Width

- Definition: The image dimension settings can be applied as a Window of Interest or a Region of Interest, depending on the image dimension mode selected in the **Database Mode** command.
- Serial Cmd: <**K255**,index,exposure,gain,focal distance,pixel binning,row pointer,column pointer, row depth,**column width**,ymbology,morphology operator,morphology size>
- Default: **QSXGA: 2592**
SXGA: 1280
WVGA: 752
- Options: **QSXGA**: 8 to (2592 – column pointer)
SXGA: 8 to (1280 – column pointer)
WVGA: 8 to (752 – column pointer)

Symbology

Definition:	<p>This field allows the user to configure the database to enable specific symbologies for selected database indexes. Symbology-specific parameters must be configured with the appropriate symbology command.</p> <p>For example, if fixed length Code 128 is required, it must first be set up with the Code 128 command: <K474>.</p> <p>To select a particular symbology, add the number value associated with that symbology.</p> <p>Examples:</p> <p>If Data Matrix and Code 39 are required, the parameter would be: 2 + 16 = 18.</p> <p>If I 2/5, BC412, and DataBar Limited are required, the parameter would be: 128 + 2048 + 16384 = 18560.</p>
Serial Cmd:	<K255,index,exposure,gain,focal distance,pixel binning,row pointer,column pointer, row depth,column width, symbology ,morphology operator,morphology size>
Default:	Disabled

- **Disabled**

When **Symbology** is disabled, the database uses the current **Symbology** setup to determine active symbologies.

- **Any Symbology (Add 1)**

All symbologies except Pharmacode are enabled while this database index is being used.

- **Data Matrix (Add 2)**

If enabled, Data Matrix will be active for this database index.

Important: The ECC level must be configured using the Data Matrix command <K479>. If no ECC level has been configured, the reader will not decode Data Matrix symbols.

- **QR Code (Add 4)**

If enabled, QR Code will be active for this database index.

- **Code 128 (Add 8)**

If enabled, Code 128 will be active for this database index.

- **Code 39 (Add 16)**

If enabled, Code 39 will be active for this database index.

- **Codabar (Add 32)**

If enabled, Codabar will be active for this database index.

- **Code 93 (Add 64)**

If enabled, Code 93 will be active for this database index.

- **Interleaved 2 of 5 (Add 128)**

If enabled, Interleaved 2 of 5 will be active for this database index.

- **UPC/EAN (Add 256)**

If enabled, UPC/EAN will be active for this database index.

- **PDF417 (Add 512)**

If enabled, PDF417 will be active for this database index.

- **MicroPDF417 (Add 1024)**

If enabled, MicroPDF417 will be active for this database index.

- **BC412 (Add 2048)**

If enabled, BC412 will be active for this database index.

- **Pharmacode (Add 4096)**

If enabled, Pharmacode will be active for this database index.

- **DataBar-14 (Add 8192)**

If enabled, DataBar-14 will be active for this database index.

– **Important:** If the stacked and non-stacked operation is required, the DataBar-14 command must be configured as follows: <K482,2>. If the DataBar-14 status parameter in the <K482> command is set to either Disabled or Enabled, the reader will only read non-stacked DataBar-14 symbols.

- **DataBar Limited (Add 16384)**

If enabled, DataBar Limited will be active for this database index.

- **DataBar Expanded (Add 32768)**

If enabled, DataBar Expanded will be active for this database index.

– **Important:** If the stacked and non-stacked operation is required, the DataBar Expanded command must be configured as follows: <K484,2>. If the DataBar Expanded status parameter in the <K484> command is set to either Disabled or Enabled, the reader will only read non-stacked DataBar Expanded symbols.

- **Micro QR Code (Add 65536)**

If enabled, Micro QR Code will be active for this database index.

- **Aztec (Add 131072)**

If enabled, Aztec will be active for this database index.

- **Postal Symbologies (Add 262144)**

If enabled, Postal Symbologies will be active for this database index.

Morphology Operator

Definition: Specifies the morphology operation (erode, dilate, open, close) used to pre-process the WOI.

Serial Cmd: <K255,index,exposure,gain,focal distance,pixel binning,row pointer,column pointer, row depth,column width,symbology,morphology operator,morphology size>

Default: Disabled

Morphology Size

Definition: Specifies the morphology operator size to apply: **Small (3 x 3), Medium (5 x 5), and Large (7 x 7).**

Serial Cmd: <K255,index,exposure,gain,focal distance,pixel binning,row pointer,column pointer, row depth,column width,symbology,morphology operator,**morphology size**>

Default: **Small(3 x 3)**

12.5. Database Mode

Switch Mode

Definition: Selects the event that causes the reader to load the next database entry to current, active settings. When **Frame Count/Time** expires and **Image Process Looping** is enabled, the next database entry with modifications to camera settings will be used.



NOTE!

The image capture event always occurs when the first database entry is used.



NOTE!

The **Switch Mode** setting has no effect on **Rapid Capture Mode**, which always operates in **Number of Image Frames** mode with a frame count of 1.

Serial Cmd: <K256,switch mode,frame count/time,image process looping,image dimensions>
Default: 1
Options: 0 = Time 1 = Number of Image Frames

• **Time**
When **Switch Mode** is set to **Time**, the reader will load the next database entry to current, active settings after a predefined time interval. The timer will start upon use of a database entry. If the timer expires during an image capture event, the timer will not start again until that database entry has been incremented and the new database entry has been loaded to current, active settings.

• **Number of Image Frames**
When **Switch Mode** is set to **Number of Image Frames**, the database entry is incremented after the predetermined number of image capture events has occurred.

Frame Count/Time

Definition: Indicates the Number of Image Frames that must be captured or the amount of Time that must transpire before the reader will load the next database index entry.
Serial Cmd: <K256,switch mode,frame count/time,image process looping,image dimensions>
Default: 1 (frames or ms)
Options: 1 to 65535

Image Process Looping

Usage: Useful in applications where it is necessary to process a single captured image multiple times using different IP and decode parameters.
Serial Cmd: <K256,switch mode,frame count/time,image process looping,image dimensions>
Default: Disabled
Options: 0 = Disabled 1 = Enabled

- **Disabled**

When **Image Process Looping** is set to **Disabled**, an image is captured for every database configuration, whether or not any camera settings have been modified.

- **Enabled**

When **Image Process Looping** is set to **Enabled**, the last captured image frame is re-processed with the new IP and decode parameters. If camera settings have not been changed from the last capture event, and when a database configuration is loaded to current, active settings, no new image is captured.

NOTE!



An exception to this is the first database index: a new image is always captured when the first database index is used. When a camera setting has been modified from one database setting to the next, a new image is captured. For example, if all database entries contained the same camera setting values but had different IP and decode parameters, an image frame would only be captured when the first database configuration was used.

Image Dimensions

Definition: Determines how the image dimension parameters will be implemented. Serial Cmd:
<K256,switch mode,frame count/time,image process looping,**image dimensions**>
Default: **0**
Options: **0 = Window of Interest** 1 = Region of Interest

- **Region of Interest (ROI)**

When **Image Dimensions** is set to Region of Interest, the database image dimension parameters are IP and decode settings, and they determine the region or area of the captured image to be processed.

ROI coordinate data is based on the full image size. The **WOI** of the captured image will be configured to cover all the ROI settings in the current, active database entry. In the following example, there are three active database settings, each with a different ROI configuration. Their coordinates are based at point 0,0 of the full scale image. In this example, **DB1** and **DB3** determine the size of the captured image WOI, while DB2 has no impact. The image WOI is not configurable. It is automatically set up by the database according to the ROI settings.

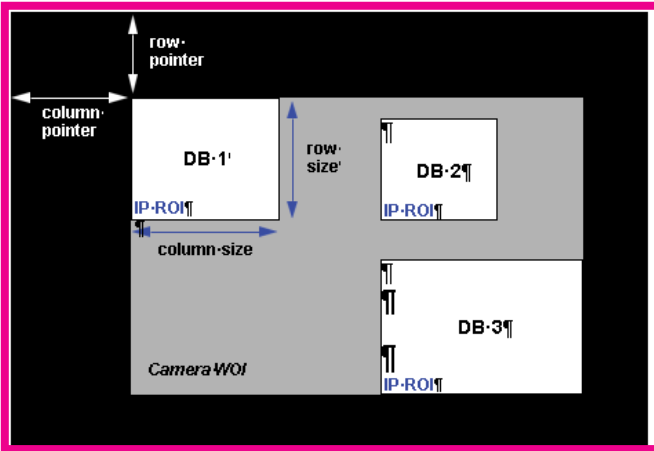

Full Image Size (SXGA Reader: 1280 x 960; WVGA Reader: 752 x 480)



NOTE!

Since the ROI parameters are not a camera setting, a change in ROI parameters from one index to another does not indicate an image capture event.

This feature is intended to be used in conjunction with **Image Process Looping**, to allow different regions of a captured image to be processed using different IP and decode settings.

Also, if this feature is used in conjunction with **Output Filtering**, multiple decoded symbols in a captured image frame can be output according to their location in the field of view.

12.6. Save Current Settings to Configuration Database

Definition: Allows current, active configuration settings to be saved to a selected database index.
Serial Cmd: <K255+,index>

Example:

<K255+,5>

This command phrase saves the reader's current, active configuration settings to database index 5.

12.7. Load Current Settings from Configuration Database

Definition: Allows the configuration settings contained in a selected database index to be loaded to current, active configuration settings.

Serial Cmd: <K255-,index>

Example:

<K255-,5>

This command phrase loads the configuration settings contained in database index 5 to current, active configuration settings.

Notes on Symbol Type

- The **current** DataBar Expanded status does not change if it is configured as Enabled (Stacked) and the **database** DataBar Expanded status is Enabled.
- The **current** DataBar-14 status does not change if it is configured as Enabled (Stacked) and the **database** DataBar Expanded status is Enabled.
- Data Matrix ECC level is determined by the **current** settings and not by **database** settings. Therefore, the database does not know which ECC level to enable, and has no effect on current Data Matrix ECC settings.

12.8. Request Selected Index Settings

Definition: Returns configuration settings for the selected database index.
Serial Cmd: <K255?,index>

Example:

<K255?,5>

This command phrase returns the configuration settings for database index 5.

12.9. Request All Configuration Database Settings

Definition: Returns configuration settings for all indexes in the Configuration Database.

Serial Cmd: <K255?>

Example:

<K255?>

This command phrase returns the configuration settings for all 10 database indexes.

13. Utilities

Utility commands are generally commands that are performed during reader operations to check or determine read rates, or to perform miscellaneous operations on reader hardware. Serial utility commands are not prefaced with a “K” and a numeric code, nor do they require an initialization command (<A> and <Z>). They can be entered from within any terminal program or from WebLink’s Terminal window.

- Operational Commands 231
- Read Rate 233
- Counters 234
- Device Control 235
- Master Database 236
- Firmware 238
- Default/Reset/Save 239
- Reader Status Requests 241
- Other Operational Serial Commands 243

13.1. Operational Commands

Type	Command	Name
Counter Request/Clear	<q>	No-Reads Per Read Cycle Counter
	<q0>	No-Reads Per Read Cycle Counter Reset
	<\$>	Mismatch Per Read Cycle Counter
	<\$0>	Mismatch Per Read Cycle Counter Reset
	<N>	No-Read Counter
	<O>	No-Read Counter Reset
	<T>	Trigger Counter
	<U>	Trigger Counter Reset
	<V>	Match Code Counter
	<W>	Match Code Counter Reset
	<X>	Mismatch Counter
	<Y>	Mismatch Counter Reset
Firmware Verification	<#>	Request All Part Numbers
	<#a>	Request Application Firmware Part Number
	<#b>	Request Boot Code Firmware Part Number
	<!>	Request All Firmware Checksums
	<!a>	Request Application Firmware Checksum
	<!b>	Request Boot Code Firmware Checksum
Read Rate	<!s>	Request Current Parameter Settings Checksum
	<C>	Decodes Per Second Test
	<Cp>	Decode Percent Test
	<J>	Exit Read Rate Tests
Device Control	<a1>	Preface PDF417 Output with Data Attributes
	<L1>	Pulse Programmable Output 1
	<L2>	Pulse Programmable Output 2
Read Cycle Enable/Disable	<L3>	Pulse Programmable Output 3
	<I>	End Current Read Cycle until <H>
	<H>	Enable Read Cycle after <I>
	<I1> ¹	Activate Targeting System
Parameter Reset/Save	<I0> ²	Deactivate Targeting System
	<A?/1>	Complete Reset when Resets or Save for Power-On Command Has Been Issued
	<A?/0>	Warm Reset if Power-On Command Has Been Issued

¹ <I1> = lowercase 'L', one

² <I0> = lowercase 'L', zero

Type	Command	Name
Resets	<A>	Software Reset, Current Parameters Retained
	<Ard>	Software Reset, Recall Default Parameters except Communication and Custom Unit Name Parameters
	<Arp>	Software Reset, Recall Power-On Default Parameters
	<Arc>	Software Reset, Recall Customer Default Parameters
Save for Power-On	<Z>	Software Reset, Save Current Settings for Power-On
	<Zc>	Software Reset, Save Current Settings as Customer Default Parameters
	<Zrc>	Software Reset, Recall Customer Default Parameters and Save for Power-On
	<Zrd>	Software Reset, Recall wenglor Default Parameters Except Communication and Custom Unit Name Parameters and Save for Power-On
	Save for Power-On	Software Reset, Recall wenglor Default Parameters Including Communication and Custom Unit Name Parameters and Save for Power-On
Master Database	<G>	Store Next Symbol Read to Database Index 1
	<Gn>	Store Next Symbol Read to Database Index n
	<NEWM>	New Master Load Status
Reader Status	<?>	Reader Status Request
Train/Optimize	<TRAIN>	Initiate Train Operation
	<UNTRAIN>	Initiate Untrain Operation
	<TRAIN?>	Train Status Request
	<OPT>	Initiate Optimize Operation
	<UNOPT>	Initiate Un-Optimize Operation
	<OPT?>	Display Optimize Status
Barcode Configuration	<BCCFG>	Enter Barcode Configuration
Symbol Quality	<VAL3>	ISO/IEC 15415 Grading Report
	<VAL4>	ISO/IEC 15416 Grading Report
	<VAL5>	ISO/IEC 29158 Grading Report

13.2. Read Rate

Read Rate Serial Utility Commands

- **Enter Decodes/Second Test**

Sending <C> instructs the reader to transmit the decodes per second and symbol data (if any). The decode rate can vary dramatically due to the angle and location of the symbol in relation to the field of view. This test is very useful in aligning and positioning the reader during setup.

- **Enter Percent Test**

Sending <Cp> instructs the reader to transmit the percentage of decodes and any decoded symbol data.

- **End Read Rate Test**

Sending <J> ends both the Percent test and the Decodes/Second test.

13.3. Counters

Counters by Serial Command

- **No-Read Counter**

Sending <N> displays the total number of No-Reads that have occurred since the last reset.

- **No-Read Counter Reset**

Sending <O> sets the No-Read Counter to 0.

- **Trigger Counter**

Sending <T> displays the total number of triggers since the last reset.

- **Trigger Counter Reset**

Sending <U> sets the trigger counter to 0.

- **Good Read/Match Counter (or Good Read Counter)**

Sending <V> displays the total number of good reads matching the master symbol, or, if Master Symbol is not enabled, the number of good reads since the last reset. This counter is always enabled, but will only work as a match count when Master Symbol is enabled. If Master Symbol is not enabled, this counter records the number of good reads. This count can be requested at any time.

- **Good Read/Match Counter Reset**

Sending <W> sets the Match Counter to 0.

- **Mismatch Counter**

Sending <X> displays the number of decoded symbols since the last reset that do not match the master symbol.

- **Mismatch Counter Reset**

Sending <Y> sets the Mismatch Counter to 0.

13.4. Device Control

Device Control by Serial Command

- **Output 1 Pulse**

Sending <L1> activates the link between Output 1 (+) and Output 1 (-) of the host connector (regardless of Master Symbol or Output 1 status).

- **Output 2 Pulse**

Sending <L2> activates the link between Output 2 (+) and Output 2 (-) of the host connector (regardless of Master Symbol or Output 2 status).

- **Output 3 Pulse**

Sending <L3> activates the link between Output 3 (+) and Output 3 (-) of the host connector (regardless of Master Symbol or Output 3 status).

- **Disable Reader**

Sending <I> will turn the reader OFF, end the current read cycle, and will not allow the reader to enter another read cycle until turned ON. This feature is useful during extended periods of time when no symbols are being decoded, or the reader is being configured. Disabling the reader will not affect any commands that have already been downloaded.

- **Enable Reader**

Sending <H> will turn the reader ON and allow it to enter read cycles.

13.5. Master Database

Master Symbol Database Size

Definition: **Number of Master Symbols** allows you to select **1 to 10** master symbols for the master symbol database.

Serial Cmd: **<K231,master symbol number,master symbol data>**



NOTE!

You must follow this command with a save command **<A>** or **<Z>**.

Default: **1**
Options: to 10 M

Caution: Since the total number of characters available for the master symbol database is **3000**, changes to the **Master Symbol Database Size** will re-allocate the number of characters available for each master symbol and could cause existing master symbols to be deleted (except master symbol #1, unless it also exceeds the size limitation).

The table below specifies the maximum number of characters available to each symbol according the number of master symbols defined, from 1 to 10.

Master Symbol Number	Maximum Characters	Master Symbol Number	Maximum Characters
# 1	3000	# 6	500
# 2	1500	# 7	428
# 3	1000	# 8	375
# 4	750	# 9	333
# 5	600	# 10	300

Enter Master Symbol Data

Usage: Allows you to enter master symbol data for any enabled master symbol index number (1 to 10), provided the total number of characters does not exceed the maximum allowed.

Serial Cmd: **<K231,master symbol number,master symbol data>**

Options: Enter data for 1 to 10 symbols (any combination of ASCII text up to the maximum allowed. For example, to enter data for master symbol 9, after making certain that master symbol database size is enabled for 9 or more symbols, send**<K231,9,data>**.

Important: The ASCII characters **<**, **>**, and **,** can only be entered as hex values.

Caution: If no data is entered, the existing data will be deleted.

Request Master Symbol Data

- Definition: Returns master symbol data for any enabled master symbols from 1 to 10. For example, to request master symbol # 5, enter **<K231?,5>**. The reader transmits master symbol # 5 data in brackets in the following format: **<5/>**.
If no master symbol data is available, the output will be: **<5/>**.
- Serial Cmd: **<K231?,master symbol number>**
Caution: Be sure to add the ? or you will delete the master symbol.



NOTE!

This command returns the number of master symbols if no number is included.

Request All Master Symbol Data

- Definition: This command will return master symbol data for all symbols enabled (up to 10).
- Serial Cmd: **<K231?>**

Read Next Symbol as Master Symbol

- Definition: After you've set the size in the database, you can order the reader to read the next symbol as the master symbol for any given master symbol number.
- Serial Cmd: **<Gmaster symbol number>**
To store the next symbol decoded as master symbol # 1, send:
<G> or **<G1>**.
To store the next symbol decoded as the master symbol for any other master symbol database number, send:
<Gmaster symbol number [1-10]>.
For example, **<G5>** will cause the next symbol read to be entered as master symbol # 5.

Request New Master Status

- Usage: Informs the user when a new master symbol is pending and which position it is in.
- Definition: Returns the position in the master symbol database that will be loaded on the next read.
- Serial Cmd: **<NEWM>**
The reader returns: **<NEWM/next master to load>**
Once a symbol has been read and loaded, the status will be cleared and the response will be **<NEWM/0>**
(See also **New Master Pin in Matchcode.**)

Delete Master Symbol Data

- Definition: You can directly delete the master symbol data by serial command.
- Serial Cmd: **<K231,master symbol number,>**
To delete a master symbol, enter the database number and a comma, but leave the data field empty. For example, to delete master symbol # 5, send the following: **<K231,5,>**. The command is entered with a blank master symbol data field, which tells the reader to delete the selected master symbol from the database.

13.6. Firmware

Firmware Update

Application code versions are specific to your reader. Consult with your sales representative before downloading application code. If needed, an application code file will be sent to you.

Firmware Verification

- **Request Part Number by Serial Command**

- When you send <#> (a request for all product part numbers), the reader returns:
<#b/BOOT_P/N><#a/APP_P/N><#p/PROFILE_P/N>.
- When you send <#a> (a request for the application code part number), the reader returns:
<#a/APP_P/N>.
- When you send <#b> (a request for the boot code part number), the reader returns:
<#b/BOOT_P/N>.
- When you send <#p> (a request for profile module part numbers), the reader returns:
<#p/PROFILE_P/N>.

- **Request Checksum by Serial Command**

- When you send <!> (a request for all available firmware checksums), the reader returns:
<#b/BOOT_CHECKSUM><#a/APP_CHECKSUM><#p/PROFILE_CHECKSUM>
- When you send <!a> (a request for the application code checksum), the reader returns:
<#a/APP_CHECKSUM>
- When you send <!b> (a request for the boot code checksum), the reader returns:
<#b/BOOT_CHECKSUM>
- When you send <!p> (a request for profile module checksum), the reader returns:
<#p/PROFILE_CHECKSUM>

13.7. Default/Reset/Save

Understanding and controlling your reader's active, saved, and default settings is critical to its successful operation.

	Function	Serial Cmd
Resets (not saved for power-on)	Reset	<A>
	Reset and Recall wenglor Defaults	<Ard>
	Reset and Recall Power-On Parameters	<Arp>
	Reset and Recall Customer Default Parameters	<Arc>
Saved for Power-on	Save Current Settings for Power-On	<Z>
	Save Current Settings as Customer Default Parameters for Power-On	<Zc>
	Recall wenglor Default Parameters and Save for Power-On	<Zrd>
	Recall Customer Default Parameters and Save for Power-On	<Zrc>

Resets

Resets ("A" commands) affect only the current settings (active memory) and are not saved for power-on.

Saved for Power-On

Power-on parameters ("Z" commands) are saved to NOVRAM and recalled and loaded into current parameters when power is cycled to the reader or the <Arp> command is issued.

Defaults

Defaults are wenglor firmware settings or saved customer settings that can be recalled, either by software or hardware reset.

Customer Default Parameters

Customer default parameters (saved by <Zc>) are the same set of parameters as power-on parameters but are saved in a different, isolated section of NOVRAM. This allows a user essentially to create a backup set of parameters that can be recalled in the event that the current parameters or power-on parameters have been accidentally changed or are no longer desired.

It is important to note that a hardware default does not affect customer default parameters. For example, a user that has inadvertently changed communication settings and saved them with a <Z> command, may not know the correct settings or have the capability to communicate within those settings. By first doing a hardware default to restore the known wenglor defaults, the user can then recall the previous customer saved settings with an <Arc> or <Zrc> command.

wenglor Default Parameters

wenglor default parameters are contained in the firmware and cannot be changed.

Software Defaults

wenglor default parameters can be recalled (loaded into current settings) with <Ard> command or recalled and saved for power-on with the <Zrd> command.

Hardware Default

If a software default and reset is not possible, it may be necessary to reset the reader by shorting (connecting) specific pins. This procedure has the same effect as the <Zrdall> software command.

Important: For this reset to occur, this command must be executed within 60 seconds of a power-on or a reset.

- 1 Apply power to the reader.
- 2 Locate Pin 3 (Default) and Pin 7 (Ground) on the connector. (Access depends on wiring configuration. May require an accessory cable).

Caution: Be certain that the correct pins are located. Connecting the wrong pins could cause serious damage to the unit.

- 3 Momentarily connect the wires (or pins).
- 4 Within 3 seconds, disconnect and then reconnect the two wires again.

13.8. Reader Status Requests

<?> Status Byte

The reader responds to a status request <?> with a two character hex value, such as <?/22>. To determine status:

1 Look up the binary conversion in the table below.

For example, the first hex 2 would be 0 0 1 0 in binary, as read from binary digits 3 through 0; the second hex 2 is also 0 0 1 0 as read from binary digits 7 through 4.

2 Next, enter your binary values from the table below in the “Binary” column next to the appropriate bit.

Hex Value	Binary Bit Digits			
	7	6	5	4
0	0	0	0	0
1	0	0	0	1
2	0	0	1	0
3	0	0	1	1
4	0	1	0	0
5	0	1	0	1
6	0	1	1	0
7	0	1	1	1
8	1	0	0	0
9	1	0	0	1
A	1	0	1	0
B	1	0	1	1
C	1	1	0	0
D	1	1	0	1
E	1	1	1	0
F	1	1	1	1

Bit	Binary	Reader Status
0	0	Command error detected
1	1	Command received
2	0	Communication error detected
3	0	Flash sector unprotect failure
4	0	Host port buffer overflow
5	1	Reader is in a read cycle

3 Under “Binary,” interpret 1s as true and 0s as not true. For example, bit 1 has a 1 in the “Binary” column, indicating “Command Received”. Bit 5 is also a 1, indicating that the “Reader is in a read cycle”.

<K?> All Status Request

This is the fastest way to learn the reader's current configuration. Sending this request will return the current settings of all commands, starting with the lowest K command value and ending with the highest K command value.

<K??> All Descriptor Status Request

This request will return all current descriptors for every K command, starting with the lowest K command value and ending with the highest K command value.

<K?#> All Range Status Request

This request will return the current settings of all commands within the user-defined range, starting with the lowest user-defined K command value and ending with the highest user-defined K command value.

<Knnn?> Single Status Request

This request will return the value of the variables associated with the requested K command. The request of a single entry of a database command cannot exceed the number of database slots for the specific command. M

<Knnn??> Single Descriptor Status Request

This request returns the basic functional description of all fields in the requested K command.

<Knnn?#> Single Range Status Request

This request will return the value range and storage type description of all fields in the requested K command.

<Knnn?*> Display Command Wildcard

This request will return the individual K command status, description, and range for each parameter.

13.9. Other Operational Serial Commands

The following serial utility commands can be entered from Terminal or a PLC:

Train and Optimize

Train Symbol

Format: **<TRAIN>**: Initiates a Train operation.

This command will put the product into a mode of operation that will cause it to “train” the next symbol decoded. This mode of operation will remain active until either a symbol is decoded or the call is made to disable the mode and revert back to normal operation. Upon decoding a symbol, the image processing will save pertinent information regarding the target symbol to allow higher readability for the similar symbols. The data collected by the Train operation can be saved for a power-on condition, using the **<Z>** command.

Un-Train Symbol

Format: **<UNTRAIN>**: Initiates an Un-Train operation.

This command will cause the product to discard any information acquired during a Train operation. The Un-trained state can be saved for a power-on condition, using the **<Z>** command.

Train Status

Format: **<TRAIN?>**: Responds with Train Status

This command will return the current status of the TRAIN operation.

Response: **< TRAIN,0>**: Default, not trained

<TRAIN,1>: Train operation in process

<TRAIN,2>: Symbol trained

Train Persistence

The train state and parameters persist the same as ordinary parameters. Examples:

- A unit in the trained state has not been saved. A power cycle will remove any trained state information and the unit will come up in its configured state.
- A unit is saved in a training state. The unit will come from power up in the training state and train the first symbol read.
- A unit is saved in a trained state. The unit will come from power up in the trained state and only read the trained symbol type.
- A trained unit is issued a reset default command **<Ard>**. The unit will return to an untrained state but if power is cycled will return to its saved state.

Optimize Symbol

Format: **<OPT>** Initiates an Optimize operation.

This command will put the product into a mode of operation that will cause it to “optimize” the next symbol decoded. This mode of operation will remain active until either a symbol is decoded or the call is made to disable the mode and revert back to normal operation. Upon decoding a symbol, the image processing will save pertinent information regarding the target symbol to allow it to be processed quicker and more consistently. The data collected by the Optimize operation can be saved for a power-on condition, using the **<Z>** command.

Un-Optimize Symbol

Format: <UNOPT>: Initiates an Un-Optimize operation.

This command will cause the product to discard any information acquired during a Optimize operation. The Un-Optimized state can be saved for a power-on condition, using the <Z> command.

Optimize Status

Format: <OPT?>: Responds with Optimize Status

This command will return the current status of the OPT operation.

Response: <OPT,0>: Default, not optimized

<OPT,1>: Optimize operation in-process

<OPT,2>: Symbol optimized

Optimize Persistence

The Optimize state and parameters persist the same as ordinary parameters. Examples:

- A unit in the optimized state has not been saved. A power cycle will remove any optimized state information and the unit will come up in its configured state.
- A unit is saved in a optimizing state. The unit will come from power up in the optimizing state and optimize the first symbol read.
- A unit is saved in a optimized state. The unit will come from power up in the optimized state and only read the optimized symbol type.
- A optimized unit is issued a reset default command <Ard>. The unit will return to an un-optimized state but if power is cycled will return to its saved state.

Y-Modem Upload Transfer Options

<uy,path,filename>

Y-Modem Download Transfer Options

<dy,path,filename>

Image Library Request

<op,9> Manages files in a selected directory.

File Source	Explanation
(Nothing)	All files in "root" directory
/	All files in "root" directory
/saved	All files in "saved" directory
.	All files in all directories
/del	Deletes all files in the root directory
/saved/del	Deletes all files in the saved directory
del*.*	Deletes files in all directories

Bar Code Configuration Mode

Definition: **Bar Code Configuration Mode** is a way of programming the reader by using ECC 200 Data Matrix symbols.

Serial Cmd: **<BCCFG>**

Bar Code Configuration Mode can be entered in two different ways:

- 1 By forcing the reader into **Bar Code Configuration Mode** by serial command **<BCCFG>**.
- 2 By reading a Data Matrix symbol with a special code word used by ISO/IEC 16022 to signify reader programming. This can be either in a regular read cycle or during a read rate test. Reading this symbol in the calibration routine will have no effect.¹

Once **Bar Code Configuration Mode** has been entered, the Data Matrix symbols can be thought of as serial data. You can configure the reader by printing labels in wenglor's serial command format. Commands are processed as if the data were streamed in through the serial port. The reader will acknowledge the symbol with a green flash, and echo the serial data to the host. If the command causes the reader to produce more serial output, such as serial verification or counter requests, the data will be routed to the host port.

Bar Code Configuration Mode can be exited by any reset **<A>**, **<Z>** or **<J>** command. The command to exit Bar Code Configuration Mode can be included as part of the Data Matrix symbol. For example, try encoding **<K200,4><K220,1><J>** into a Data Matrix symbol. This configures the reader to enable Serial Trigger Mode, to program a new trigger to end the read cycle, and to exit **Bar Code Configuration Mode with <J>**.

NOTE!



When the system is in barcode configuration mode, 2D symbols are allowed to pass through even if the reader only has a 1D license. The system outputs a Config Code Received message when the configuration symbol is decoded instead of showing the configuration symbol's actual symbol data. A > character is output to the Terminal to indicate that the system is ready for barcode configuration mode.

In normal reading modes, it is required to read a special Data Matrix symbol with a special codeword used by ISO/IEC 16022 to signify reader programming.

14. Output Format

This section explains how to control the formatting and filtering of decoded symbol data for output.

Output Format Serial Commands	247
Output Format Status	247
Format Assign	248
Format Extract	249
Format Insert	250
Output Filter Configuration	251
Number of Filters	253

14.1. Output Format Serial Commands

Format Extract	<K740,output index,start location,length>
Format Insert	<K741,output index,length,hex string>
Format Assign	<K742,symbol number,status>
Format Status	<K743,output format status>
Output Filter Configuration	<K744,filter number,symbology,length,wildcard,placeholder, data,unused,-database index>
Output Format Count	<K745,number of filters>
del*.*	Deletes files in all directories

14.2. Output Format Status

Definition: This is a global enable/disable parameter. In order to use formatting you must set up the format using the insert and extract commands, and you must also assign a symbol to format using the **Format Assign** command.

Serial Cmd: <K743,output format status>

Default: **Disabled**

Options: **0 = Disabled** 1 = Enabled

Output Format Status Disabled

When **Output Format Status** is set to **Disabled**, output formatting is globally disabled.

Output Format Status Enabled

When **Output Format Status** is set to **Enabled**, output formatting is enabled. However, **Format Assign**, **Format Insert**, and **Format Extract** must be properly set up as well.

14.3. Format Assign

Symbol Number

Definition: **Symbol Number** refers to the number of the symbol to which output formatting will apply. For example, if you wish to enable user-defined formatting to symbol # 2 in a multisymbol read cycle, you would send the command **<K742,2,1>**.
Note that the number of symbols may exceed the format capabilities.

Serial Cmd: **<K742,symbol number,status>**

Options:

1 to 10

1 = Formatted output status for symbol # 1.

2 = Formatted output status for symbol # 2.

...

10 = Formatted output status for symbol # 10.

Status

Definition: **Status** refers to the user-defined formatting of a selected symbol position in the read cycle result. Note that there is also a global formatting “enable” command that must be set for the formatting to be applied.

Serial Cmd: **<K742,symbol number,status>**

Default:

Disabled

Options:

0 = Disabled

1 = Enabled (Assign parameters to specified symbol.)

14.4. Format Extract

Output Index

Definition: **Output Index** refers to the database entry you wish to modify with this command. A formatted output is built by extracting data from a symbol's original data output and/or inserting user-defined characters. It may be helpful to think of individual indexes as positions in the final formatted output you wish to build. Starting with index # 1, enter either an extract or insert command to begin building your desired output string. Then, with the next index number, enter either an extract or insert command to continue building the output string. Continue this process until you are finished building the string.

Serial Cmd: <**K740,output index,start location,length**>

Options: 1 to 100

Start Location

Definition: Defines the location within the symbol data where the character extraction will begin. The first character extracted will also be the first character in the sequence displayed in user-defined output.

Serial Cmd: <**K740,output index,start location,length**>

Default: **0 (disabled)**

Options: 0 to n (maximum number of characters in the symbol data).

Length

Definition: Defines the length (in consecutive characters) that will be extracted and placed in user-defined output.

Serial Cmd: <**K740,output index,start location,length**>

Default: **0 (disabled; end of format cell array)**

Options: 0 to n (maximum number of characters in the symbol data).

14.5. Format Insert

Output Index

Definition:

Output Index refers to the database entry you wish to modify with this command. A formatted output is built by extracting data from a symbol's original data output and/or inserting user-defined characters.

It may be helpful to think of individual indexes as positions in the final formatted output you wish to build. Starting with index # 1, enter either an extract or insert command to begin building your desired output string. Then, with the next index number, enter either an extract or insert command to continue building the output string. Continue this process until you are finished building the string.

Serial Cmd:

<**K741,output index,length,hex string**>

Options:

1 to 100

Length

Definition:

Specifies the length of the user-defined character string that will be inserted. This function is limited to 4 characters per output index, so multiple indexes must be entered in order to insert longer character sequences.

For example, if you wish to insert a 10 character sequence in user-defined output, you would need three commands with consecutive index numbers, where the first two character sequence lengths were 4 and the third was 2.

Serial Cmd:

<**K741,output index,length,hex string**>

Default:

0 (disabled; end of format cell array)

Options:

0 to 4

Hex String

Definition:

Specifies a character string that represents ASCII characters to be inserted in the database entry. Two hex characters are required for every ASCII character to be inserted in the user-defined output string. These two characters comprise the hex (base 16) value of the ASCII character.

For example, if you wanted to enter the three-character sequence "Hi!" you would enter 3 for the length of the string, and a hex sequence of **486921** for the ASCII sequence to be inserted. (48 = H; 69 = i; 21 = !)

Important: Each pair of hex characters represents one ASCII character. Hex character pairs range from 00 to FF. Since you are limited to 4 ASCII characters per insertion per database entry, you are likewise limited to 8 hex characters per insertion per database entry.

Serial Cmd:

<**K741,output index,length,hex string**>

Default:

NUL (00 in hex)

Options:

00 to FF (As many as 4 bytes, or hex values.)

14.6. Output Filter Configuration

Definition: Output filtering is a method of providing a set of good read qualifiers and also providing ordered output. There is a filter for up to the first 10 positions in a multisymbol output. The first filter corresponds to the first symbol output at the end of the read cycle. Each filter has settings for the following four parameters: Symbology, Symbol Length, Data, and Configuration Database Number.

Serial Cmd: <K744,filter number,symbology,length,wildcard,placeholder,data, unused,database index>

Rules for Output Filter Configuration

Output Filter Configuration Rule # 1

Each symbol that is decoded must match one of the filters before it can be saved to a read cycle record. There is an exception to this rule, however, when the number of symbols required for a read cycle exceeds the number of active filters. In such a case, unfiltered symbols can be placed into unfiltered output positions. For example, if the number of symbols required is 6 but there are only 4 active filters, the last 2 positions can be filled by any (unfiltered) qualified symbol.

Output Filter Configuration Rule # 2

The same filter setup can be used multiple times. For example, filters 1, 2, and 3 can be set up to filter Data Matrix symbols, and the output will occur in the order the symbols are decoded.

Output Filter Configuration Rule # 3

All qualified symbols will be sorted and output in the matching filter position. If a symbol matches filter 3, it will be output as the third symbol. If a filter does not have a matching qualified symbol, a No-Read message will be output in place of the symbol (assuming the No-Read message is enabled). For example, if there is not a symbol that meets filter 3's requirements, then a No-Read message will be output in the third output position.

Filter Number

Definition: This is the filter index number that represents the position of the symbol in the data output at the end of the read cycle. This index number should be entered along with the following filter settings for the predetermined symbol position.

Serial Cmd: <K744,filter number,symbology,length,wildcard,placeholder,data, unused,database index>

Options: 1 to 10

Placeholder

Definition: The placeholder character requires a character to be present, but does not compare the data value.

Serial Cmd: <**K744**,filter number,symbology,length,wildcard,**placeholder**,data, unused,database index>

Default: “ ? ” = **3F** (hex)

Options: Any ASCII input in the form of a pair of hex characters.
Example:
3F = ?
00 = disabled

Data

Definition: This is the data string to be used when comparing symbol data for output filtering and ordering. This data string may also contain wildcard and placeholder characters to facilitate matching. Remember that in order to filter or order symbol data, it must meet all the requirements of the selected filter index.

Examples:

- Filter data = “123*”. This will match data strings of “123”, “123456”, and “123ABC”, but not “12”.
- Filter data = “123*AB?C”. This will be interpreted as “123*”.
- Filter data = “123?”. This will match “1234” and “123A”, but not “123”, “12345”, or “1234C”.
- Filter data = “123?A”. This will match “1234A” and “123BA”, but not “123”, “1234C”, or “1234ABCD”.
- Filter data = “123?A?”. This will match “1234AB” and “123BAT”, but not “1234A” or “123BATS”.
- Filter data = “12??*”. This will match “1234”, “123456”, and “123ABC”, but not “12” or “123”.
- Filter data = “123?A*”. This will match “1234A”, “123BA”, and “123BATS”, but not “1234” or “1234C”.

Serial Cmd: <**K744**,filter number,symbology,length,wildcard,**placeholder**,**data**, unused,database index>

Default: **00** (NUL)

Options: Any ASCII input in the form of a pair of hex characters.

Maximum length: 63 bytes defined. Examples:

41422A = AB*

Data [0] = NUL represents string matching disabled.

Database Index

Definition: The index of the database entry that decodes a given symbol must equal this setting for filtering to occur. A setting of 0 allows any database index for this filter entry.

Serial Cmd: <**K744**,filter number,symbology,length,wildcard,**placeholder**,data, unused,**database index**>

Default: **0** (any index)

Options: 0 to 10

14.7. Number of Filters

Definition: **Number of Filters** refers to the number of active output filters. **0** disables all output filters. Any non-zero numeral will enable filtering to be performed using the filter indexes covered by this value.
For example, if the number of filters is **1**, then only filter index # 1 will be applied. If the number of filters is **2**, then only filter index # 1 and filter index # 2 will be applied, etc.

Serial Cmd: **<K745,number of filters>**
Default: **0**
Options: 0 to 10

15. Communications Protocol

This section contains a communications protocol command table for C5PC readers.

Communications Protocol Command Table 255

15.1. Communications Protocol Command Table

Protocol Command (Mnemonic displayed on menu)	Control Characters (Entered in menu or serial command)	Hex Value	Effect of Command
RES	^D	04	Reset
REQ	^E	05	Request
EOT	^D	04	Reset
STX	^B	02	Start of Text
ETX	^C	03	End of Text
ACK	^F	06	Acknowledge
NAK	^U	15	Negative Acknowledge
XON	^Q	11	Begin Transmission
XOFF	^S	13	Stop Transmission

16. ASCII Table

This section contains an ASCII table.

ASCII Table 257

16.1. ASCII Table

De	Hex	Mne	Ctrl
Dec	Hex		
00	00		
00	00	NUL	^@
01	01	SOH	^A
02	02	STX	^B
03	03	ETX	^C
04	04	EOT	^D
05	05	ENQ	^E
06	06	ACK	^F
07	07	BEL	^G
08	08	BS	^H
09	09	HT	^I
10	0A	LF	^J
11	0B	VT	^K
12	0C	FF	^L
13	0D	CR	^M
14	0E	SO	^N
15	0F	SI	^O
16	10	DLE	^P
17	11	DC1	^Q
18	12	DC2	^R
19	13	DC3	^S
20	14	DC4	^T
21	15	NAK	^U
22	16	SYN	^V
23	17	ETB	^W
24	18	CAN	^X
25	19	EM	^Y
26	1A	SUB	^Z
27	1B	ESC	^[
28	1C	FS	^\
29	1D	GS	^]
30	1E	RS	^^
31	1F	US	^_

Dec	Hex	Ch
32	20	SP
33	21	!
34	22	"
35	23	#
36	24	\$
37	25	%
38	26	&
39	27	'
40	28	(
41	29)
42	2A	*
43	2B	+
44	2C	,
45	2D	-
46	2E	.
47	2F	/
48	30	0
49	31	1
50	32	2
51	33	3
52	34	4
53	35	5
54	36	6
55	37	7
56	38	8
57	39	9
58	3A	:
59	3B	;
60	3C	<
61	3D	=
62	3E	>
63	3F	?

Dec	Hex	Ch
64	40	@
65	41	A
66	42	B
67	43	C
68	44	D
69	45	E
70	46	F
71	47	G
72	48	H
73	49	I
74	4A	J
75	4B	K
76	4C	L
77	4D	M
78	4E	N
79	4F	O
80	50	P
81	51	Q
82	52	R
83	53	S
84	54	T
85	55	U
86	56	V
87	57	W
88	58	X
89	59	Y
90	5A	Z
91	5B	[
92	5C	\
93	5D]
94	5E	^
95	5F	_

Dec	Hex	Ch
96	60	`
97	61	a
98	62	b
99	63	c
100	64	d
101	65	e
102	66	f
103	67	g
104	68	h
105	69	i
106	6A	j
107	6B	k
108	6C	l
109	6D	m
110	6E	n
111	6F	o
112	70	p
113	71	q
114	72	r
115	73	s
116	74	t
117	75	u
118	76	v
119	77	w
120	78	x
121	79	y
122	7A	z
123	7B	{
124	7C	
125	7D	}
126	7E	~
127	7F	D

17. Glossary of Terms

This section contains a glossary of terms relevant to C5PC readers.

Glossary of Terms 259

17.1. Glossary of Terms

Aberration — The failure of an optical lens to produce an exact point-to-point correspondence between the object and its resulting image. Various types are chromatic, spherical, coma, astigmatism and distortion.

Absorption — The loss of light of certain wavelengths as it passes through a material and is converted to heat or other forms of energy. (–)

Active Illumination — Lighting an area with a light source coordinated with the acquisition of an image. Strobed flash tubes and pulsed lasers are examples.

Ambient Light — Light which is present in the environment of the imaging front end of a vision system and generated from outside sources. This light, unless used for actual illumination, will be treated as background Noise by the vision system.

Analog — A smooth, continuous voltage or current signal or function whose magnitude (value) is the information.

Analog-to-Digital Converter (A/D Converter or ADC) — A device that converts an analog voltage or current signal to a discrete series of digitally encoded numbers (signal) for computer processing.

Application-Specific Integrated Circuit (ASIC) — An integrated circuit that is customized for a particular kind of use, rather than general use. All vision system elements including firmware can be integrated into one ASIC.

Architecture — The hardware organization of a vision system designed for high speed image analysis.

Aspect Ratio — The ratio between the height and width of a sensor or display. Found by dividing the vertical number of pixels (height) by the horizontal number of pixels (width) leaving it in fractional format.

Automatic Gain Control (AGC) — Adjustment to signal strength that seeks to maintain a constant level regardless of the distance between a reader and symbol.

Auxiliary Port — RS-232 connection to an auxiliary terminal or device for remote viewing.

Blooming — A situation in which too many photons are being produced to be received by a pixel. The pixel overflows and causes the photons to go to adjacent pixels. Blooming is similar to overexposure in film photography, except that in digital imaging, the result is a number of vertical and/or horizontal streaks appearing from the light source in the picture.

Baud Rate — The number of discrete signal events per second; bits per second.

Capture — The act of acquiring and storing video images in an imager or host computer. Also, the image captured.

Charge-Coupled Device (CCD) — A semiconductor device with an array of light-sensitive elements that converts light images into electrical signals.

Check Character — A Modulus 43 or Modulus 10 character that is added to encoded symbol data for additional data integrity.

Complementary Metal Oxide Semiconductor (CMOS) — Like CCDs, CMOS imagers include an array of photo-sensitive diodes, one diode within each pixel. Unlike CCDs, however, each pixel in a CMOS imager has its own individual amplifier integrated inside.

Connector — A plug or socket on a device or cable providing in/out connectivity for various circuits and pins.
Concentrator — Intermediary device that relays data from imagers to a host and commands from the host to the imagers or other devices.

Counter — Memory space allocated to keep track of imager events.

Daisy Chain — Linkage of primary and secondary imagers allowing data to be relayed up to the host via auxiliary port connections.

Decode — A Good Read. The successful interpretation and output of the information encoded in a symbol.

Default — Restores ROM or flash settings, initializes serial commands and resets all counters.

Delimited — A delimited command or field is bracketed by predefined characters.

Decode Rate — The number of good reads per second achieved by an imager.

Dark Field Illumination — Lighting of objects, surfaces, or particles at very shallow or low angles, so that light does not directly enter a reader's optical hardware.

Depth-of-Field — The in-focus range of an imaging system. Measured from the distance behind an object to the distance in front of the object with all objects appearing in focus.

Diffused Lighting — Scattered soft lighting from a wide variety of angles used to eliminate shadows and specular glints from profiled, highly reflective surfaces.

Digital-to-Analog Converter (DAC) — A VLSI circuit used to convert digitally processed images to analog for display on a monitor.

Digital Imaging — Conversion of an image into pixels by means of an Analog-to-Digital Converter where the level of each pixel can be stored digitally.

Digital Signal Processor (DSP) — A VLSI chip designed for ultra-high-speed arithmetic processing. Often imbedded in a vision engine.

Discrete I/O — Inputs and outputs characterized by discrete signal transitions from one voltage level to another so that digital switching can occur.

Direct Memory Access (DMA) — A capability provided by some computer bus architectures that allows data to be sent directly to memory from an attached device.

Dynamic Range — The difference between the minimum and maximum thresholds of discernible images; the amount of usable signal.

Edge Enhancement — Image processing method to strengthen high-spatial frequencies in the image.

Embedded Memory — Onboard memory device such as EPROM or flash.

End of Read Cycle — The time or condition at which the imager stops expecting symbol information to decode.

Erasable Programmable Read-Only Memory (EPROM) — A memory chip that retains data when its power supply is turned off; “non-volatile memory”.

External Edge — Allows a read cycle to be initiated by a trigger signal from an object detector when it detects the appearance of an object (rising edge). The read cycle ends with a good read, a timeout, or a new trigger.

External Level — Allows a read cycle to be initiated by a trigger signal from an object detector. The read cycle ends when the object moves out of the detector’s range.

Falling Edge — A change of state (to inactive) associated with a level trigger.

Field-Programmable Gate Array (FPGA) — A semiconductor device containing programmable interconnects and logic components.

Fill Factor — Percentage of pixel area used for light collection.

Firmware — Software hard-coded in non-volatile memory (ROM), and closely tied to specific pieces of hardware.

Fixed Symbol Length — Increases data integrity by ensuring that only one symbol length will be accepted.

Focal Distance — In camera-based vision, the distance from the front of the camera to the object being viewed. (In optics, the distance from the lens to the focal plane.)

Focal Plane — Usually found at the image sensor, it is a plane perpendicular to the lens axis at the point of focus (–).

Focus — Any given point in an image at which light converges; the focal point.

Frame — The total area captured in an image sensor while the video signal is not blanked.

Frame Grabber — A device that interfaces with a camera and, on command, samples the video, converts the sample to a digital value and stores that in a computer’s memory.

Front End System — The object, illumination, optics and imager blocks of a vision system. Includes all components useful to acquire a good image for subsequent processing.

Full Duplex — A communications system in which signals can travel simultaneously between devices.

Gain — The amount of energy applied to pixel gray scale values prior to output, expressed in dB; optimal signal strength.

Good Read — A decode. The successful scanning and decoding of the information encoded in a bar code symbol.

Gradient — The rate of change of pixel intensity (first derivative).

Gray Scale — Variations of values from white, through shades of gray, to black in a digitized image with black assigned the value of zero and white the value of one.

Half Duplex — A communications system in which signals can travel between devices in both directions, but

not simultaneously.

Histogram — A graphical representation of the frequency of occurrence of each intensity or range of intensities (gray levels) of pixels in an image. The height represents the number of observations occurring in each interval.

Host — A computer, PLC, or other device that is used to execute commands and process data and discrete signals.

Image — Projection of an object or scene onto a plane (i.e. screen or image sensor).

Image Processing (IP) — Transformation of an input image into an output image with desired properties.

Image Resolution — The number of rows and columns of pixels in an image. A higher resolution means that more pixels are available per element of the symbol being read. Examples: 640 x 480 (VGA); 854 x 480 (WVGA); 1280 x 1024 (SXGA); 2048 x 1536 (QXGA).

Image Sensor — A device that converts a visual image to an electrical signal; a CCD or CMOS array.

Initialize — Implement serial configuration commands into the imager's active memory.

Input — A channel or communications line. Decoded data or a discrete signal that is received by a device.

Integration — Exposure of pixels on a CMOS sensor.

Ladder Orientation — A linear symbol orientation in which the bars are parallel to the symbol's direction of travel.

Light-Emitting Diode (LED) — A semiconductor device that emits light when conducting current.

Lens — A transparent piece of material with curved surfaces which either converge or diverge light rays.

Machine Vision — The automatic acquisition and analysis of images to obtain desired data for controlling a specific activity.

Multidrop — A communications protocol for networking two or more imagers or other devices with a concentrator (or controller) and characterized by the use of individual device addresses and the RS-485 standard.

Noise — The same as static in a phone line or "snow" in a television picture, noise is any unwanted electrical signal that interferes with the image being read and transferred by the imager.

Normally Closed — A discrete output state that is only active when open.

Normally Open — A discrete output state that is only active when closed.

Object Plane — An imaginary plane in the field of view, focused by an imager's optical system at the corresponding image plane on the sensor.

Output — A channel or communications line. Data or discrete signals that are transmitted or displayed by a device.

Parity — An error detection routine in which one data bit in each character is set to 1 or 0 so that the total

number of 1 bits in the data field is even or odd.

Picket Fence Orientation — A linear symbol orientation in which the bars are perpendicular to the symbol's direction of travel.

Pitch — Rotation of a linear or 2D symbol around an axis parallel to the symbol length on the Substrate.

Pixel — An individual element in a digitized image array; "picture element".

Port — Logical circuit for data entry and exit. (One or more ports may be included within a single connector.)

Processing Time — The time used by a vision system to receive, analyze and interpret image information. Often expressed in "parts per minute".

Programmable Logic Controller (PLC) — An electronic device used in industrial automation environments such as factory assembly lines and automotive manufacturing facilities.

Progressive Scan — A non-interlaced scan that doubles the number of visible picture lines per field by displaying all picture lines at once.

Protocol — The rules for communication between devices, providing a means to control the orderly flow of information between linked devices.

Random Access Memory (RAM) — A data storage system used in computers, composed of integrated circuits that allow access to stored data in any sequence without movement of physical parts.

Read Cycle — A programmed period of time or condition during which a reader will accept symbol input.

Read-Only Memory (ROM) — A data storage medium used in computers and other electronics, primarily used to distribute Firmware.

Real-Time Processing — In machine vision, the ability of a system to perform a complete analysis and take action on one part before the next one arrives for inspection.

Region — Area of an image. Also called a region of interest for image processing operations.

Saturation — The degree to which a color is free of white. One of the three properties of color perception, along with hue and value.

Scattering — Redirection of light reflecting off a surface or through an object.

Skew — Rotation of a linear or 2D symbol around an axis parallel to the symbol height on the substrate.

Substrate — The surface upon which a linear or 2D symbol is printed, stamped, or etched.

Symbol Transitions — The transition of bars and spaces on a symbol, used to detect the presence of a symbol on an object.

Symbology — A symbol type, such as Code 39 or Code 128, with special rules to define the widths and positions of bars and spaces to represent specific numeric or alphanumeric information.

Tilt — Rotation of a linear or 2D symbol around an axis perpendicular to the substrate.

Trigger — A signal, transition, or character string that initiates a read cycle.

Very Large-Scale Integration (VLSI) — The creation of integrated circuits by combining thousands of transistor-based circuits on a single chip.

Watchdog Timer — A security device that detects system crashes and attempts to reset the imager.

18. Q & A

This section answers some common questions about C5PC functionality.

Question	Answer
<p>Is the settings possible without any PC tool and PLC?</p>	<p>It is possible to do by reading a DataMatrix for the setting.</p> <p>The following describes how to generate DataMatrix for the setting.</p> <ol style="list-style-type: none"> 1. Connect C5PC. 2. Receive the setting data of C5PC. 3. Select the Utilities - Differences Tab. 4. Click the Differences from Default Button. 5. Click the Generate Bar Code Button. 6. As The Bar code configuration dialog appears, place a check to the Add Start configuration code and Add end configuration code; Save Settings. 7. Click the Print Button to print the DataMatrix for the settings. <p>The following describes how to read the DataMatrix for the settings.</p> <ol style="list-style-type: none"> 1. To reflect the settings, turn on V430 in the factory shipment.state. → (In the factory shipment) the state is set to Continuous Read. 2. Read the Add start configuration code first. → The LEDs on the device flash in order. (Bar Code Configuration Mode) 3. Read the DataMatrix generated for setting commands in order. 4. Read Add end configuration code in the last. → The Bar code configuration mode ends and the settings are saved.
<p>What is PPE?</p>	<p>PPE stands for Pixel Per Element.</p> <p>For 2D code, it is one cell size on a captured image.</p> <p>For 1D code (barcode), it is the minimum bar width on a captured image.</p> <p>e.g. When [PPE=4.0] is displayed on WebLink at DataMatrix read, the DataMatrix cell size is four pixels on the captured image.</p>
<p>When magnifying an image on WebLink, it blurs.</p>	<p>On WebLink, compressed images are displayed.</p> <p>Since such images have lower resolution than measured images, therefore they might be blur when magnifying them.</p> <p>When magnifying a measured image with an actual resolution, use saved images. For the image saving method, refer to Q&A: How to save read images.</p>

Question	Answer
How to react when being unable to WebLink.	<ul style="list-style-type: none"> • For Internet Explorer, check the following settings. Uncheck the upper right Tool icon - Compatibility View settings - Display Intranet sites in Compatibility View. Or use Google Chrome. • Turn off the VPN function. Turn off the VPN function. When the VPN function is turned on, local LAN connections other than the VPN are disabled all. • Check the IP address using DDU. DDU (Discovery Device Utility) is a tool to search a C5PC whose IP address is lost. When the search was succeeded, its IP address also can be changed. Download the DDU from wenglorg Web site. • Initialize C5PC if the above measures does not help. Related Q&A: How to initialize the settings?
About WebLink	<p>The merits of WebLink are that does not require the installation and is easily operated to set with a Web browser. Use WebLink basically. Most of the functions are settable except for some functions. The following shows a list of comparison.</p> <p>WebLink Merits:</p> <ul style="list-style-type: none"> • No installation software (Web browser) • Japanese supported • Visually easy to understand UI
Can the position information of a code be output?	<p>Enable Advanced – I/O – Output Object Info – Output Coordinates. Following the captured string, every four vertexes of the code are output.</p> <ul style="list-style-type: none"> • Output example: When a code of 123456 was captured 123456,(0032,0040)(0287,0056)(0287,0279)(0048,0271)
Can serial commands calibrate brightness or focus?	<p>It is possible to adjust with a serial command <@CAL> executing the calibration. Which parameter should be adjusted at Calibration, it is selectable with the following parameter on WebLink.</p> <p>Advanced – I/O tab – Calibration Options</p> <p>When executing the <@CAL> command, C5PC outputs numeric values indicating trial results in some rows and then Calibration PASSED. When failed, Calibration FAILED is output.</p> <p>Example of a response when <@CAL> was succeeded.: Prog Exposure Gain Brightness</p> <pre>2 5764 33 24 100 6011 33 37 Calibration PASSED.</pre>

Question	Answer										
How is a trigger inputted in serial communications?	<p>The following describes a serial command to input a trigger in default.</p> <ul style="list-style-type: none"> Serial Trigger command ASCII character notation < > Hex notation 3C 20 3E <p>Although space is a default in the center (Hex notation: 20), it can be changed to any ASCII character from the menu below.</p> <p>WebLink – Gear icon – Advanced – Read Cycle – Serial Trigger – Serial Trigger Character (Delimited)</p> <p>Additionally, from the menu below, any ASCII character can be set up to two characters for Start Trigger Character/Stop Trigger Character that do not need < >.</p> <p>WebLink – Gear icon – Advanced – Read Cycle – Serial Trigger – Start Trigger Character (Non-Delimited)/Stop Trigger Character (Non-Delimited)</p>										
What kind of effect is in Teaching?	<p>When Teaching (Hat icon on WebLink) was executed, judgment of code type and the detection algorithm optimization are performed.</p> <p>When reading codes with the same conditions, the reading will be more stable just to execute Teaching.</p> <p>However, Teaching is not a function that always needs be executed.</p>										
How to access a RAM drive from a PC?	<p>A PC can access a RAM drive using the FTP client tool. The initial values of C5PC are as follows.</p> <table border="1" data-bbox="249 671 622 834"> <thead> <tr> <th>Settings</th> <th>Value</th> </tr> </thead> <tbody> <tr> <td>IP address</td> <td>192.168.100.1</td> </tr> <tr> <td>Path</td> <td>imagesd0/images/</td> </tr> <tr> <td>Account</td> <td>target</td> </tr> <tr> <td>Password</td> <td>password</td> </tr> </tbody> </table> <p>Example: When using Internet Explorer to access.</p> <ol style="list-style-type: none"> If the IP address is the default, enter ftp://192.168.100.1/imagesd0/images/ in the address bar to connect. Enter your account and password. Download the file saved in the RAM drive to your PC. 	Settings	Value	IP address	192.168.100.1	Path	imagesd0/images/	Account	target	Password	password
Settings	Value										
IP address	192.168.100.1										
Path	imagesd0/images/										
Account	target										
Password	password										

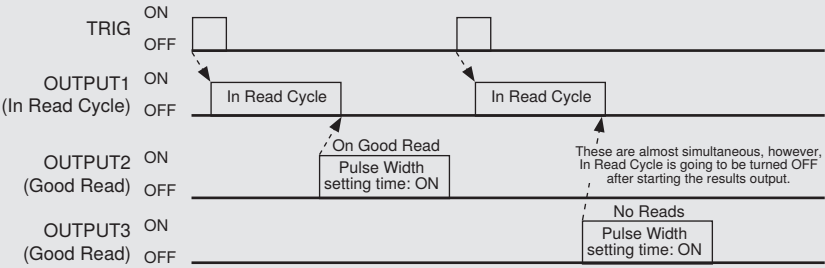
Question	Answer
Parallel communications timing chart	<p>The parallel output signals, OUTPUT1/OUTPUT2/OUTPUT3, can change those roles by the output condition settings.</p> <p>The default is that those are turned on when all are No-Read.</p> <p>WebLink – Gear icon – Advanced – I/O – OUTPUT1 parameters – Output On. Additionally, a timing to turn off can also be adjusted using the following setting. WebLink – Gear icon – Advanced – I/O - OUTPUT1 parameters – Output Mode</p> <p>When you want to detect a timing that the output is changed, set the output condition for one of OUTPUT1/OUTPUT2/OUTPUT3 to In Read Cycle.</p> <p>According to the setting, it turns on in a period from detecting a trigger, reading, and end of output.</p> <p>For example, the following describes a timing chart in a case of a setting below.</p> <ul style="list-style-type: none"> • Output On <ul style="list-style-type: none"> OUTPUT1 In Read Cycle OUTPUT2 Match or Good Read OUTPUT3 Mismatch or No-Read • Timing chart <ul style="list-style-type: none"> <Output Mode: Pulse case> 

Question	Answer
----------	--------

<Output Mode: Latch Mode 2 (Status held) case>

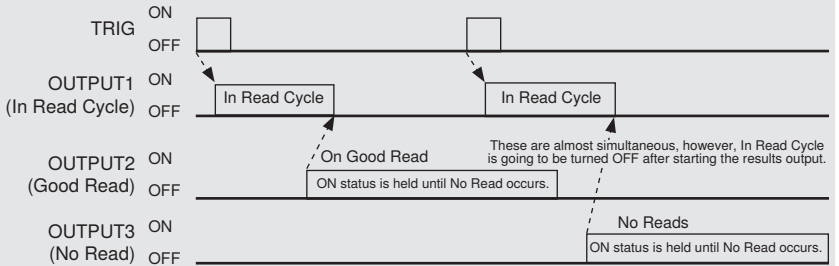

<Output Mode: Latch Mode 3 (OFF at In Read Cycle started) case>

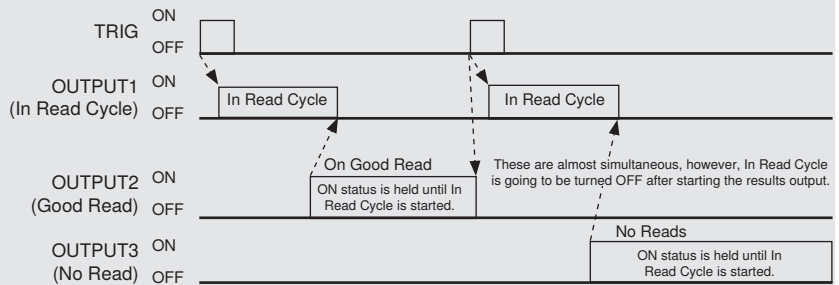

How to estimate an exposure time when reading a moving symbol?

A moving amount of a symbol during exposure should be 1/10 or less of the cell size (for barcode, narrow bar width).
 When a cell size is C [mm] and a line speed is L [mm/s], use the following formula to get the exposure time S.
 $S \leq 0.1 \times C / L$
 For example, When a cell size is 0.3 [mm] and a line speed is 300 [mm/s], the exposure time should be 100 [μs] or less.
 $0.1 \times 0.3 \text{ [mm]} / 300 \text{ [mm/s]} = 100 \text{ [μs]}$

Question	Answer																												
<p>Read Rate of Counts on the right panel is not available.</p>	<p>Read Rate of Counts on the right panel is sometimes not available depending on the setting of Read Cycle.</p> <table border="1" data-bbox="255 245 703 440"> <thead> <tr> <th>Read Cycle</th> <th>Read Rate</th> </tr> </thead> <tbody> <tr> <td>Presentation</td> <td>Unavailable</td> </tr> <tr> <td>Continuous Read</td> <td>Unavailable</td> </tr> <tr> <td>Triggered</td> <td>Available</td> </tr> <tr> <td>Start/Stop</td> <td>Available</td> </tr> <tr> <td>Custom</td> <td>Refer to below</td> </tr> </tbody> </table> <p>When Read Cycle is Custom, it sometimes is unavailable depending on the setting of Trigger Mode.</p> <table border="1" data-bbox="255 520 790 778"> <thead> <tr> <th>Trigger Mode</th> <th>Read Rate</th> </tr> </thead> <tbody> <tr> <td>Continuous Read</td> <td>Unavailable</td> </tr> <tr> <td>Continuous Read 1 Output</td> <td>Unavailable</td> </tr> <tr> <td>External Level</td> <td>Available</td> </tr> <tr> <td>External Edge</td> <td>Available</td> </tr> <tr> <td>Serial Data</td> <td>Available</td> </tr> <tr> <td>Serial Data and Edge</td> <td>Available</td> </tr> <tr> <td>Continuous Read Auto</td> <td>Unavailable</td> </tr> </tbody> </table>	Read Cycle	Read Rate	Presentation	Unavailable	Continuous Read	Unavailable	Triggered	Available	Start/Stop	Available	Custom	Refer to below	Trigger Mode	Read Rate	Continuous Read	Unavailable	Continuous Read 1 Output	Unavailable	External Level	Available	External Edge	Available	Serial Data	Available	Serial Data and Edge	Available	Continuous Read Auto	Unavailable
Read Cycle	Read Rate																												
Presentation	Unavailable																												
Continuous Read	Unavailable																												
Triggered	Available																												
Start/Stop	Available																												
Custom	Refer to below																												
Trigger Mode	Read Rate																												
Continuous Read	Unavailable																												
Continuous Read 1 Output	Unavailable																												
External Level	Available																												
External Edge	Available																												
Serial Data	Available																												
Serial Data and Edge	Available																												
Continuous Read Auto	Unavailable																												
<p>Only one image can save.</p>	<p>When Save Image Until is set to New Read Cycle, only last one image is saved. When saving multiple images, set WebLink - Gear icon - Advanced - Image Storage - Save Image Until to System Reset. Additionally, when Image Storage Location was set to FTP, images might not be saved due to the shorter read interval if Transfer Optimization is set to Speed (Lossy). When you want to prioritize the image storage over the read, set WebLink - Gear icon - Advanced - Image Storage - Transfer Optimization to Accuracy (Lossless).</p>																												
<p>How to acquire or change the settings from external?</p>	<p>With the serial communications, it is possible to do so using a serial command so called K command. For each K command, refer to Chapter 3 or later. Example: Set the exposure time to 1,000 [μs]. Command: <K541,1000> Response: None</p> <p>As adding “?” to a K command, the setting value will be returned. Example: Acquire the current exposure time and gain. Command: <K541?> Response: <K541,1000,30> Presently, the exposure time is set to 1,000 [μs] and the gain is set to 30 [%].</p>																												

Question	Answer																		
How can I read multiple codes in the field of view?	<p>When the string of codes are different from each other, multiple codes in the field of view can be read.</p> <ul style="list-style-type: none"> • Settings To enable multiple reads, change the value of default Look for 1 Symbols in Read Cycle at the left on the setup screen. Or, change the settings below. WebLink - Gear icon - Advanced - Read Cycle - Multisymbol - Number of Symbols • Output order The output order is practically random because of the order of completed read. Using the Configuration Database or Order Output Filter functions with serial commands, up to 10 output order can be controlled (when symbols satisfy the output conditions). • Cautions Multiple reads are not available in codes with the same string. 																		
Is it possible to specify the output range for output string?	<p>Turn on Output Format at the left on the WebLink setup screen. With clicking format strings, Output Formatting Editor screen opens. With enabling Parse Symbol, the output range can be specified.</p>																		
What kinds of lighting patterns are adopted?	<table border="1"> <thead> <tr> <th data-bbox="253 772 381 828">LED</th> <th data-bbox="385 772 665 828">Purpose</th> <th data-bbox="668 772 872 828">WebLink Setting menu</th> <th data-bbox="875 772 1079 828">Simultaneous lighting</th> </tr> </thead> <tbody> <tr> <td data-bbox="253 833 381 963">Outside LED</td> <td data-bbox="385 833 665 963">Imaging LED Mainly use when illuminating a wide range. 5M type is white. 0.3M and 1.2M types are red.</td> <td data-bbox="668 833 872 1177" rowspan="3">Advanced – Camera Setup – Camera Settings</td> <td data-bbox="875 833 1079 1177" rowspan="3">These three cannot be turned on simultaneously. Only one of the lighting patterns can be set.</td> </tr> <tr> <td data-bbox="253 968 381 1043">Inside red LED</td> <td data-bbox="385 968 665 1043">Imaging LED Use this when red color lighting is needed.</td> </tr> <tr> <td data-bbox="253 1048 381 1177">Inside white LED</td> <td data-bbox="385 1048 665 1177">Imaging LED Use this when illuminating a narrow range. The purpose is changeable with the setting.</td> </tr> <tr> <td data-bbox="253 1182 381 1289">Green LED</td> <td data-bbox="385 1182 665 1289">Illuminate at a good read (default). Additional green lighting at imaging. Target pattern lighting.</td> <td data-bbox="668 1182 872 1401" rowspan="2">Advanced – I/O – Output Indicator</td> <td data-bbox="875 1182 1079 1401" rowspan="2">Possible to turn it on with other lighting LED simultaneously.</td> </tr> <tr> <td data-bbox="253 1294 381 1401">Blue LED</td> <td data-bbox="385 1294 665 1401">This turns on when leading the image center position to the cross part of the blue lighting.</td> </tr> </tbody> </table>	LED	Purpose	WebLink Setting menu	Simultaneous lighting	Outside LED	Imaging LED Mainly use when illuminating a wide range. 5M type is white. 0.3M and 1.2M types are red.	Advanced – Camera Setup – Camera Settings	These three cannot be turned on simultaneously. Only one of the lighting patterns can be set.	Inside red LED	Imaging LED Use this when red color lighting is needed.	Inside white LED	Imaging LED Use this when illuminating a narrow range. The purpose is changeable with the setting.	Green LED	Illuminate at a good read (default). Additional green lighting at imaging. Target pattern lighting.	Advanced – I/O – Output Indicator	Possible to turn it on with other lighting LED simultaneously.	Blue LED	This turns on when leading the image center position to the cross part of the blue lighting.
LED	Purpose	WebLink Setting menu	Simultaneous lighting																
Outside LED	Imaging LED Mainly use when illuminating a wide range. 5M type is white. 0.3M and 1.2M types are red.	Advanced – Camera Setup – Camera Settings	These three cannot be turned on simultaneously. Only one of the lighting patterns can be set.																
Inside red LED	Imaging LED Use this when red color lighting is needed.																		
Inside white LED	Imaging LED Use this when illuminating a narrow range. The purpose is changeable with the setting.																		
Green LED	Illuminate at a good read (default). Additional green lighting at imaging. Target pattern lighting.	Advanced – I/O – Output Indicator	Possible to turn it on with other lighting LED simultaneously.																
Blue LED	This turns on when leading the image center position to the cross part of the blue lighting.																		
Is the lighting brightness adjustable?	<p>The lighting brightness is adjustable using the menu on WebLink. Gear icon – Advanced – Camera Settings – Illumination Brightness</p>																		

Question	Answer															
How to output the same code only once in Constant Read state?	<p>To output the same code only once in Constant Read state with C5PC, set the following.</p> <ul style="list-style-type: none"> • Gear icon - Advanced - Read Cycle - Trigger - Mode: Continuous Read 1 Output • Gear icon - Advanced - Read Cycle - End of Read Cycle - Mode: New Trigger <p>With the above setting, C5PC in Constant Read state reads the same code only once and only output it when a code different from the previous code is read.</p> <p>When you want to set C5PC so that it can read the same code again after some time passed, set</p> <p>End of Read Cycle Mode to Timeout and adjust Read Cycle Timeout.</p>															
How to initialize the settings?	<p>There are three initialization methods.</p> <ul style="list-style-type: none"> • Initialization by operating the menu on WebLink <ol style="list-style-type: none"> 1. Click the Gear icon at the right of WebLink. 2. Click the Restore Default Settings Button. <p>* This performs an initialization processing as same as a serial command <Zrd>.</p> • Boot while pressing the Setup Button. <p>Customer Default Parameters are loaded.</p> <ol style="list-style-type: none"> 1. Hold down the Setup Button on the main body and turn on the power. 2. Keep the state for approx. 30 seconds. <p>* This performs an initialization processing as same as a serial command <Zrd>.</p> • Initialization by DEFAULT signal of parallel. <p>It resets the hardware. The following I/O signals are used.</p> <table border="1" data-bbox="249 794 799 956"> <thead> <tr> <th>Line color</th> <th>PIN No.</th> <th>Signal name</th> </tr> </thead> <tbody> <tr> <td>Brown</td> <td>2</td> <td>24 VDC (Power)</td> </tr> <tr> <td>Green</td> <td>3</td> <td>Default</td> </tr> <tr> <td>Blue</td> <td>7</td> <td>0 VDC (Ground)</td> </tr> <tr> <td>Red</td> <td>8</td> <td>COM_IN</td> </tr> </tbody> </table> <p>Before turning on, connect PIN 2 and 8.</p> <p>Perform the following procedures within 60 seconds after turning on.</p> <ol style="list-style-type: none"> 1. Connect PIN 3 to PIN 7. 2. Disconnect the connection between PIN 3 and PIN 7. 3. Connect PIN 3 to PIN 7 again within 3 seconds after the disconnection. 4. Disconnect the connection after starting the reboot. <p>* This performs an initialization processing as same as a serial command <Zrdall>.</p> <p>NOTE!</p> <p> When the system is in barcode configuration mode, 2D symbols are allowed to pass through even if the reader only has a 1D license. The system outputs a Config Code Received message when the configuration symbol is decoded instead of showing the configuration symbol's actual symbol data. A > character is output to the Terminal to indicate that the system is ready for bar code configuration mode.</p>	Line color	PIN No.	Signal name	Brown	2	24 VDC (Power)	Green	3	Default	Blue	7	0 VDC (Ground)	Red	8	COM_IN
Line color	PIN No.	Signal name														
Brown	2	24 VDC (Power)														
Green	3	Default														
Blue	7	0 VDC (Ground)														
Red	8	COM_IN														

Question	Answer
How to save read images?	<p>The read images are possible to save with the following procedures.</p> <ul style="list-style-type: none"> • Save images on WebLink. Click Save Current Image button at the right end on the Image Control Toolbar at the upper right on the image area to save the read image to your PC. The file is download to a destination you set with a browser. • Save images to the RAM drive. Images read according to Read Cycle can be saved in the RAM drive on C5PC. Click Gear icon at the upper right - Image Storage to open Image Save Options, and set the conditions to save images. Click the Advanced button to set other parameters such as Save Image Until. Such saved images can be saved in a PC via FTP. Regarding the method to save images via FTP, refer to “How to access a RAM drive from a PC?”. Regarding No. of images savable to the RAM drive, refer to “How many sheets of images can be saved in the RAM drive?”. It is initialized when turning off the power because of RAM drive. • Save images to a FTP server. Images read according to Read Cycle can be saved to an FTP server on the network. Click Gear icon at the upper right - Image Storage to open Image Save Options, and set the conditions to save images. Select FTP for the Image Storage Location. By setting the FTP address of the FTP server after that, images can be saved in it. <p>* Re-reading is not available by using the saved images.</p>
How to check read characters?	<p>When checking character strings, turn on Matchcode at the left panel on WebLink. Click Mode of Matchcode and register character strings you want to check to Match String Database. Up to 10 strings are registrable to Match String Database.</p>
What is the smallest size of the readable 2D code?	<p>A 2D code with 2x2 pixels or more in the cell size on an image is readable. This figure is a theoretical value. In practice, test it for the judgment.</p>
What is the smallest size of the readable barcode?	<p>In ideal, a barcode with the size below is readable.</p> <p>Barcode width: 1 pixel or more Barcode height:16 pixels or more</p> <p>These figures are theoretical values. In practice, test it for the judgment.</p>
What is the method to evaluate the reading stability?	<p>There are two methods.</p> <ul style="list-style-type: none"> • ISO print quality evaluation The ISO print quality evaluation is a function to evaluate the read stability compatible for the ISO standards. For example, use ISO 29158 to evaluate DataMatrix of DPM. Enable Gear icon - Advanced - Symbol Quality - ISO/IEC 29158 Parameters, which add an evaluation results to the end of a read character strings. • Read Rate Mode Operating the Setup Button or performing the Read Rate command makes the device to Rear Rate mode. The operation display LED on the body becomes to indicate the Read Rate and the body is set to a state to output the rate via the serial (RS-232C) communications or TCP communications.

Question	Answer														
What is the number of the maximum readable characters?	C5PC can read up to the maximum numbers defined each code standard. For example, although up to 7,089 characters can be input to QR code based on the standard, C5PC can read the code.														
What is the readable installation distance?	That of C5PC depends on the cell size (bar width) of a target code too. The reference values are described on page A-5 to A-6, refer to them. The read range is described, which was possible to read with typical cell size examples for the design readable focal distance per format. * For barcode, a half size of the bar width for readable values of 2D code cell size is a guide.														
How to shorten the read time?	Please consider below. <ul style="list-style-type: none"> • Construct appropriate optical conditions like an image is in focus or having sufficient contrast. Mount distance, Mount angle, Exposure time) • Limit symbol types for the read target. • Enable the optimization. (Graph icon on the setup screen) • Perform the Window of Interest. 														
What parameters need to be adjusted when a symbol is unable to read?	Adjust the following parameters. <table border="1" data-bbox="252 671 1077 1023"> <thead> <tr> <th>Symbol state</th> <th>Adjustment</th> </tr> </thead> <tbody> <tr> <td>An image is dark.</td> <td>Adjust Exposure or Gain to bright the image.</td> </tr> <tr> <td>Out of focus.</td> <td>Adjust Focus to make the symbol in focus.</td> </tr> <tr> <td>A cell size is small.</td> <td>Change the mount distance or use a high pixel density and narrow field of view type.</td> </tr> <tr> <td>Noisy background</td> <td>Remove noise with the Morphological Preprocessing. When 5 M type is used, adjust the color filter.</td> </tr> <tr> <td>The read time takes much time.</td> <td>Set Timeout longer.</td> </tr> <tr> <td>The lighting is reflected.</td> <td>Tilt the lighting by approx. 15 degrees to reduce the reflection. Or, try to use the optional Polarizer (ZNNG031) and the Diffuser (ZNNG030).</td> </tr> </tbody> </table>	Symbol state	Adjustment	An image is dark.	Adjust Exposure or Gain to bright the image.	Out of focus.	Adjust Focus to make the symbol in focus.	A cell size is small.	Change the mount distance or use a high pixel density and narrow field of view type.	Noisy background	Remove noise with the Morphological Preprocessing. When 5 M type is used, adjust the color filter.	The read time takes much time.	Set Timeout longer.	The lighting is reflected.	Tilt the lighting by approx. 15 degrees to reduce the reflection. Or, try to use the optional Polarizer (ZNNG031) and the Diffuser (ZNNG030).
Symbol state	Adjustment														
An image is dark.	Adjust Exposure or Gain to bright the image.														
Out of focus.	Adjust Focus to make the symbol in focus.														
A cell size is small.	Change the mount distance or use a high pixel density and narrow field of view type.														
Noisy background	Remove noise with the Morphological Preprocessing. When 5 M type is used, adjust the color filter.														
The read time takes much time.	Set Timeout longer.														
The lighting is reflected.	Tilt the lighting by approx. 15 degrees to reduce the reflection. Or, try to use the optional Polarizer (ZNNG031) and the Diffuser (ZNNG030).														
Is it possible to function the autofocus while reading?	The autofocus while reading can be enabled when the Read Cycle is set to Continuous Read or Continuous Read Auto . Since the autofocus adjustment needs several seconds, use the Configuration Database function when switching the mount distances that are predetermined. Related Q&A: Can serial commands calibrate brightness or focus?														
What is the number of the maximum characters for Match String Database?	It is 3,000 characters. It is divided by the number of registrations, so it varies depending on the number of registrations. When the number of registrations is one, it can register up to 3,000 characters. When the number of registrations is ten, each registration can register up to 300 characters. Related Q&A: What is the number of the maximum readable characters?														
How to change Match String externally?	Use <K231> command. Command format: <K231, index, master symbol data> Example: When setting ABC to the first Match String Database: <K231, 1, ABC>														

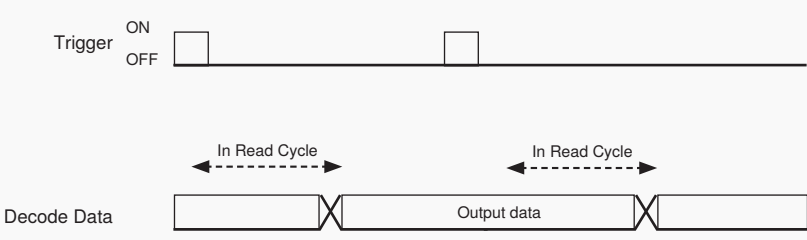
Question	Answer
How to enable the External Trigger rather than Continuous Read?	Set the Trigger Mode except for Continuous Read . Refer to the following instruction. Select Gear icon - Advanced - Read Cycle - Trigger - Mode - External Edge or Serial Data and Edge .
How can I confirm the OK/NG Read result over EtherNet/IP?	The method differs according to the selected input assembly. <ul style="list-style-type: none"> When using a Small (100) assembly; First determine whether the Output String (DECODE DATA STRING) is NOREAD (default). When using a Big (101) assembly; There is a way to verify the External Output Status OUTPUT bit. Please note that the External Output Status is dependent on the Output condition setting for the Parallel I/O OUTPUT signal. The default setting is ON when there is a Read Fail. When an assembly after MXL/SLC (102) is selected; You can verify the Read Cycle Pass, Read Cycle Fail bit status in Device Status. The Read Cycle Pass, Read Cycle Fail bit is OFF during a READ cycle and is updated when Data Is Ready is ON.
EtherNet/IP data output timing	The timing signal indicating when the output data is stored in the data memory of the PLC varies depending on the selected assembly. <ul style="list-style-type: none"> When using the Small (100) assembly, there is no applicable data output timing signal When using the Big (101) assembly, the timing of data output is when Device Status - In Read Cycle bit changes from ON to OFF. When MXL/SLC (102) or later assembly is selected, Output is at the timing when the Date Status Ready bit of Device Status turns ON. <p>– When using the Small (100) assembly, there is no applicable data output timing signal.</p>  <p>The diagram illustrates the timing relationship between the Trigger signal and the Decode Data output. The Trigger signal is shown as a horizontal line with two rectangular pulses. The first pulse is labeled 'ON' and the second is labeled 'OFF'. Below the Trigger signal, the Decode Data output is shown as a horizontal line with two rectangular pulses. The first pulse is labeled 'Decode Data' and the second is labeled 'Output data'. Dashed arrows labeled 'In Read Cycle' indicate the duration of the Decode Data and Output data pulses, which correspond to the duration of the Trigger pulses.</p>

Question	Answer
----------	--------

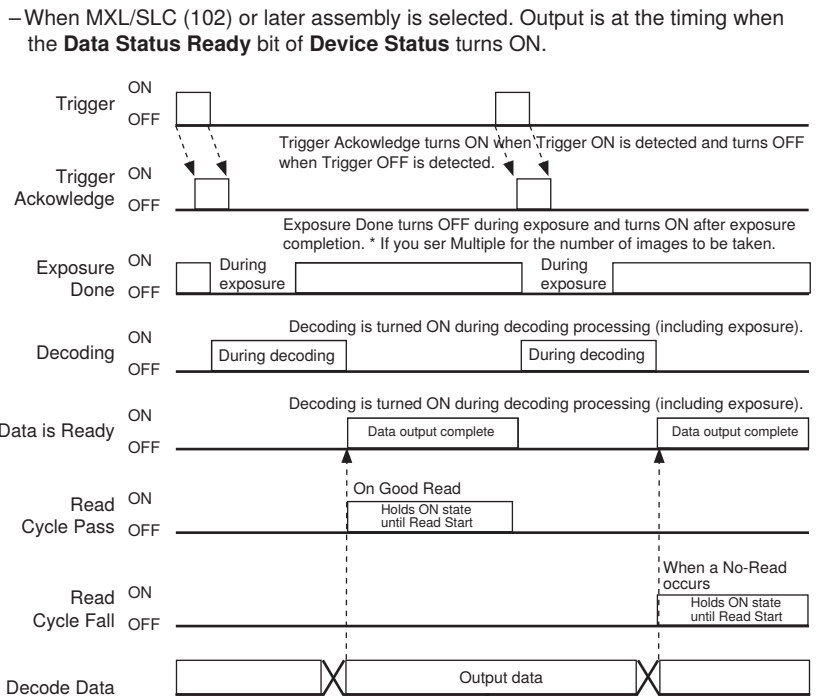
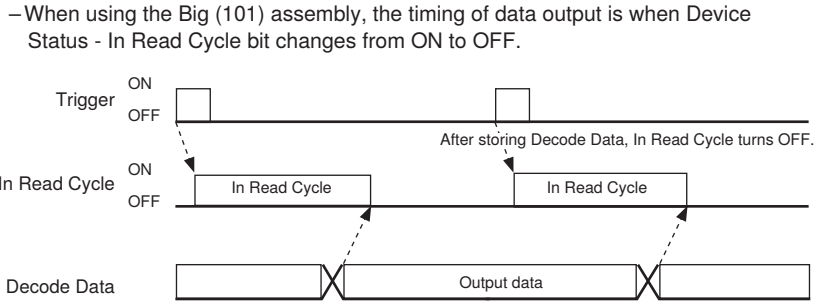

Which TCP ports does Weblink use for communication?	Weblink references port 2001 as a default TCP port, 50501 is used for sending commands to and from the unit, and port 50502 is for the cycle reports. To be safe, ports 2001, 50501 and 50502 are required for Weblink. When Weblink is unresponsive, make sure that ports 2001, 50501 and 50502 are open and available for Weblink through things like the firewalls and manage switches.
---	--

