

# Machine Vision Camera

## BB6K006

Part Number



- Compact and robust aluminum housing in 29 × 49.1 × 29 mm format
- Different lenses can be adapted thanks to standard thread
- High-resolution 4000 x 3000-pixel image chip

Machine Vision Cameras make it possible to record images in vision applications. The images are read out via a 1-gigabit Ethernet interface. The camera can be connected via a PoE port so that only one cable is required. The small and rugged aluminum housing as well as the C-mount threaded connection can be easily and flexibly integrated. The high-performance Sony Starvis image chip ensures high resolution and optimum image quality without noise even in difficult lighting conditions.

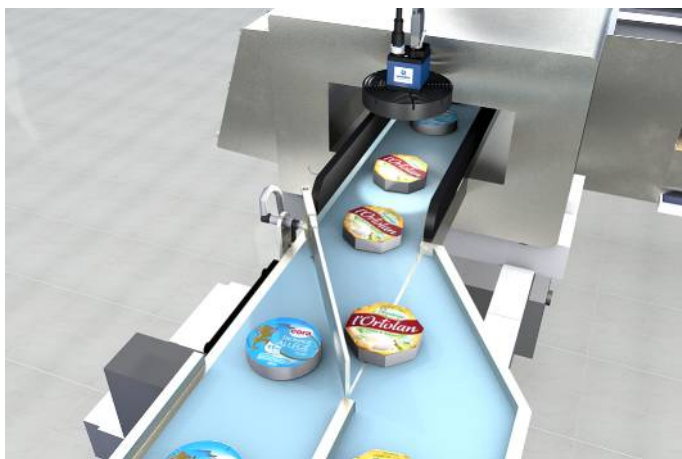

### Technical Data

| Optical Data           |                   |
|------------------------|-------------------|
| Resolution             | 4000 × 3000 Pixel |
| Resolution             | 12 MP             |
| Aspect Ratio           | 4:3               |
| Pixel Size             | 1,85 × 1,85 μm    |
| Sensor Type            | CMOS              |
| Sensor Designation     | Sony IMX226CQJ-C  |
| Image Chip             | color             |
| Image chip size        | 1/1,7"            |
| Frame rate (fullframe) | < 10 fps          |

| Electrical Data                             |                         |
|---|-------------------------|
| Supply Voltage                              | 12...24 V DC            |
| Current Consumption (U <sub>b</sub> = 24 V) | < 130 mA                |
| Temperature Range                           | 0...55 °C               |
| Storage temperature                         | -20...60 °C             |
| Atmospheric humidity                        | 20...80%                |
| Number of GPIOs (general purpose I/Os)      | 2                       |
| GPIO voltage range                          | 0...3,3 V DC            |
| GPIO maximum output current                 | 8 mA                    |
| GPIO protective circuit                     | no                      |
| Number of Flash Outputs                     | 1                       |
| Flash Output                                | Optoisolator            |
| Number of trigger inputs                    | 1                       |
| Trigger Input                               | Optoisolator            |
| Short Circuit Protection                    | no                      |
| Overload Protection                         | no                      |
| Supported PoE Classes                       | 2                       |
| Supported PoE Standard                      | IEEE802.3af, IEEE802.at |
| Protection Class                            | III                     |

| Mechanical Data             |                         |
|-----------------------------|-------------------------|
| Lens thread                 | C-Mount                 |
| Housing Material            | Aluminum, powder-coated |
| Optic Cover                 | Glass                   |
| Degree of Protection        | IP30                    |
| Connection                  | HR25, 8-pin             |
| Type of Connection Ethernet | RJ45, 8-pin             |

| Safety-relevant Data             |         |
|----------------------------------|---------|
| Diagnostic Coverage (DC)         | 0 %     |
| MTTFd (EN ISO 13849-1)           | 39,29 a |
| Mission Time TM (EN ISO 13849-1) | 20 a    |

| Function        |     |
|-----------------|-----|
| Subsampling     | yes |
| Rolling shutter | yes |

| PoE                               |             |
|-----------------------------------|-------------|
| Connection Diagram No.            | 1032   1033 |
| Suitable Connection Equipment No. | 85   47     |
| Suitable Mounting Technology No.  | 580         |

### Complementary Products

|                         |
|-------------------------|
| Control Unit BB1C       |
| EHSS001 Switch          |
| Illumination Technology |
| Lens                    |
| Software                |

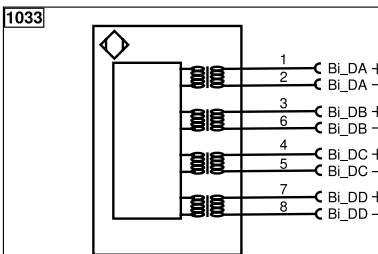
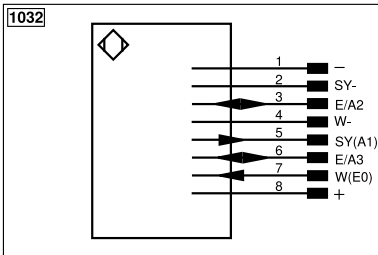
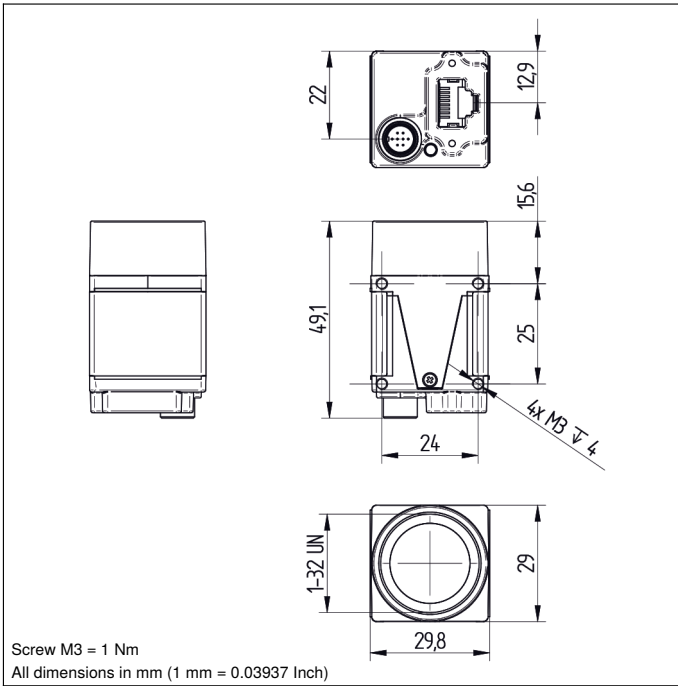

| Legend    |  |          |  |
|-----------|--|----------|--|
| +         | Supply Voltage +                           | nc       | Not connected                          |
| -         | Supply Voltage 0 V                         | U        | Test Input                             |
| ~         | Supply Voltage (AC Voltage)                | Ū        | Test Input inverted                    |
| A         | Switching Output (NO)                      | W        | Trigger Input                          |
| Ā         | Switching Output (NC)                      | W-       | Ground for the Trigger Input           |
| V         | Contamination/Error Output (NO)            | O        | Analog Output                          |
| ṽ         | Contamination/Error Output (NC)            | O-       | Ground for the Analog Output           |
| E         | Input (analog or digital)                  | BZ       | Block Discharge                        |
| T         | Teach Input                                | Amv      | Valve Output                           |
| Z         | Time Delay (activation)                    | a        | Valve Control Output +                 |
| S         | Shielding                                  | b        | Valve Control Output 0 V               |
| RxD       | Interface Receive Path                     | SY       | Synchronization                        |
| TxD       | Interface Send Path                        | SY-      | Ground for the Synchronization         |
| RDY       | Ready                                      | E+       | Receiver-Line                          |
| GND       | Ground                                     | S+       | Emitter-Line                           |
| CL        | Clock                                      | ±        | Grounding                              |
| E/A       | Output/Input programmable                  | SnR      | Switching Distance Reduction           |
| IO-Link   |  | Rx+/-    | Ethernet Receive Path                  |
| PoE       | Power over Ethernet                        | Tx+/-    | Ethernet Send Path                     |
| IN        | Safety Input                               | Bus      | Interfaces-Bus A(+)/B(-)               |
| OSSD      | Safety Output                              | La       | Emitted Light disengageable            |
| Signal    | Signal Output                              | Mag      | Magnet activation                      |
| Bi_DA+/-  | Ethernet Gigabit bidirect. data line (A-D) | RES      | Input confirmation                     |
| ENo RS422 | Encoder 0-pulse 0/0 (TTL)                  | EDM      | Contactor Monitoring                   |
| PT        | Platinum measuring resistor                | ENARs422 | Encoder A/Ā (TTL)                      |
|           |  |          | Encoder B/B̄ (TTL)                     |
|           |  |          | Encoder A                              |
|           |  |          | Encoder B                              |
|           |  |          | Digital output MIN                     |
|           |  |          | Digital output MAX                     |
|           |  |          | Digital output OK                      |
|           |  |          | Synchronization In                     |
|           |  |          | Synchronization OUT                    |
|           |  |          | Brightness output                      |
|           |  |          | Maintenance                            |
|           |  |          | Reserved                               |
|           |  |          | Wire Colors according to DIN IEC 60757 |
|           |  |          | BK Black                               |
|           |  |          | BN Brown                               |
|           |  |          | RD Red                                 |
|           |  |          | OG Orange                              |
|           |  |          | YE Yellow                              |
|           |  |          | GN Green                               |
|           |  |          | BU Blue                                |
|           |  |          | VT Violet                              |
|           |  |          | GY Grey                                |
|           |  |          | WH White                               |
|           |  |          | PK Pink                                |
|           |  |          | GNYE Green/Yellow                      |

