

# Inductive Sensor with Standard Switching Distances

## IB060NM46VD8

Part Number



### Technical Data

#### Inductive Data

Switching Distance	6 mm
Correction Factors Stainless Steel V2A/CuZn/Al	0,76/0,54/0,54
Mounting	non-flush
Switching Hysteresis	< 15 %

#### Electrical Data

Supply Voltage	10...30 V DC
Current Consumption (U <sub>b</sub> = 24 V)	< 6 mA
Switching Frequency	600 Hz
Temperature Drift	< 10 %
Temperature Range	-25...80 °C
Switching Output Voltage Drop	< 2,5 V
Switching Output/Switching Current	200 mA
Residual Current Switching Output	< 100 µA
Short Circuit Protection	yes
Reverse Polarity Protection	yes
Overload Protection	yes
Protection Class	III

#### Mechanical Data

Housing Material	CuZn, nickel-plated
Full Encapsulation	yes
Degree of Protection	IP67
Connection	M8 × 1; 3-pin

#### Safety-relevant Data

MTTFd (EN ISO 13849-1)	5246,99 a
------------------------	-----------

PNP NC

Connection Diagram No.

109

Suitable Connection Technology No.

8

Suitable Mounting Technology No.

170 | 173

### Complementary Products

PNP-NPN Converter BG8V1P-N-2M

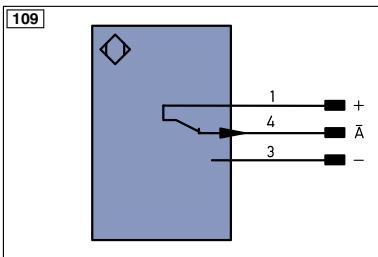
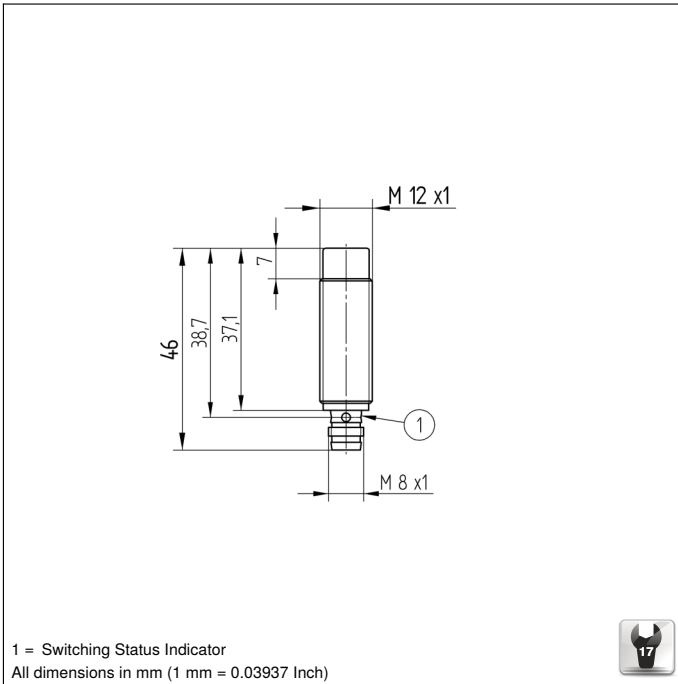

Legend	
+	Supply Voltage +
-	Supply Voltage 0 V
~	Supply Voltage (AC Voltage)
A	Switching Output (NO)
$\bar{A}$	Switching Output (NC)
V	Contamination/Error Output (NO)
$\bar{V}$	Contamination/Error Output (NC)
E	Input (analog or digital)
T	Teach Input
Z	Time Delay (activation)
S	Shielding
RxD	Interface Receive Path
TxD	Interface Send Path
RDY	Ready
GND	Ground
CL	Clock
E/A	Output/Input programmable
	IO-Link
PoE	Power over Ethernet
IN	Safety Input
OSSD	Safety Output
Signal	Signal Output
Bl..D +/-	Ethernet Gigabit bidirect. data line (A-D)
EN0..RS422	Encoder 0-pulse 0-0 (TTL)
PT	Platinum measuring resistor
nc	not connected
U	Test Input
$\bar{U}$	Test Input inverted
W	Trigger Input
O	Analog Output
O-	Ground for the Analog Output
BZ	Block Discharge
AwV	Valve Output
a	Valve Control Output +
b	Valve Control Output 0 V
SY	Synchronization
E+	Receiver-Line
S+	Emitter-Line
$\pm$	Grounding
SnR	Switching Distance Reduction
Rx +/-	Ethernet Receive Path
Tx +/-	Ethernet Send Path
Bus	Interfaces-Bus A(+)/B(-)
La	Emitted Light disengageable
Mag	Magnet activation
RES	Input confirmation
EDM	Contactorm Monitoring
ENAR5422	Encoder A/ $\bar{A}$ (TTL)
ENBR5422	Encoder B/ $\bar{B}$ (TTL)
ENa	Encoder A
ENb	Encoder B
AMIN	Digital output MIN
AMAX	Digital output MAX
AOK	Digital output OK
SY In	Synchronization In
SY OUT	Synchronization OUT
OLt	Brightness output
M	Maintenance

Wire Colors according to DIN IEC 757

BK	Black
BN	Brown
RD	Red
OG	Orange
YE	Yellow
GN	Green
BU	Blue
VT	Violet
GY	Grey
WH	White
PK	Pink
GNYE	Green/Yellow

