

Reflex Sensor

with Background Suppression

HW11PA3S901

Part Number



- Adjustable switching distance
- No blind spot due to attachment tube
- Red light
- Stainless steel housing

These sensors detect distance by measuring angles. They are particularly good at recognizing objects in front of any background. The color, shape and surface characteristics of the object have practically no influence on sensor switching performance.

Technical Data

Optical Data	
Range	120 mm
Setting Range	35...120 mm
Switching Hysteresis	< 5 %
Light Source	Red Light
Service Life (T = +25 °C)	100000 h
Max. Ambient Light	10000 Lux
Light Spot Diameter	see Table
Electrical Data	
Supply Voltage	10...30 V DC
Current Consumption (U _b = 24 V)	< 30 mA
Switching Frequency	600 Hz
Response Time	833 μs
Temperature Drift	< 5 %
Temperature Range	-25...60 °C
Switching Output Voltage Drop	< 2,5 V
PNP Switching Output/Switching Current	200 mA
Short Circuit Protection	yes
Reverse Polarity Protection	yes
Overload Protection	yes
Protection Class	III
Mechanical Data	
Setting Method	Potentiometer
Housing Material	Plastic, PBT
Housing Material	Stainless steel, V2A (1.4305 / 303)
Degree of Protection	IP67
Connection	M12 × 1; 4-pin
Scope of delivery	1 × initial start-up instructions 1 × sensor
PNP NC, PNP NO	●
Connection Diagram No.	101
Control Panel No.	D18
Suitable Connection Equipment No.	2
Suitable Mounting Technology No.	150

* Valid for all sensors from revision B. The revision can be found in the production order number "xxxxx/B/xxxxxx", which is indicated on the product label.

Complementary Products

PNP-NPN Converter BG2V1P-N-2M

Ctrl. Panel

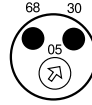
D18

05 = Switching Distance Adjuster
 30 = Switching Status/Contamination Warning
 68 = Power LED

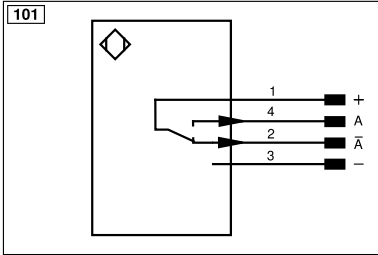
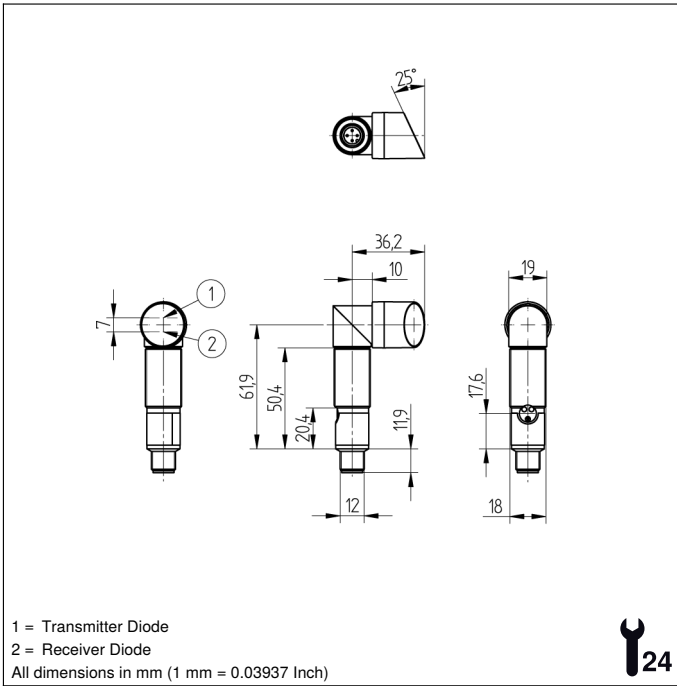

Legend					
+	Supply Voltage +	PT	Platinum measuring resistor	ENARs422	Encoder A/Ā (TTL)
-	Supply Voltage 0 V	nc	Not connected	ENBRs422	Encoder B/B̄ (TTL)
~	Supply Voltage (AC Voltage)	U	Test Input	ENa	Encoder A
A	Switching Output (NO)	Ū	Test Input inverted	ENb	Encoder B
Ā	Switching Output (NC)	W	Trigger Input	AMIN	Digital output MIN
V	Contamination/Error Output (NO)	W-	Ground for the Trigger Input	AMAX	Digital output MAX
V̄	Contamination/Error Output (NC)	O	Analog Output	AOK	Digital output OK
E	Input (analog or digital)	O-	Ground for the Analog Output	SY In	Synchronization In
T	Teach Input	BZ	Block Discharge	SY OUT	Synchronization OUT
R	Reset input	Amv	Valve Output	OLT	Brightness output
Z	Time Delay (activation)	a	Valve Control Output +	M	Maintenance
S	Shielding	b	Valve Control Output 0 V	rsv	Reserved
RxD	Interface Receive Path	SY	Synchronization	Wire Colors according to DIN IEC 60757	
TxD	Interface Send Path	SY-	Ground for the Synchronization	BK	Black
RDY	Ready	E+	Receiver-Line	BN	Brown
GND	Ground	S+	Emitter-Line	RD	Red
CL	Clock	⊕	Grounding	OG	Orange
E/A	Output/Input programmable	SnR	Switching Distance Reduction	YE	Yellow
	IO-Link	Rx+/-	Ethernet Receive Path	GN	Green
PoE	Power over Ethernet	Tx+/-	Ethernet Send Path	BU	Blue
IN	Safety Input	Bus	Interfaces-Bus A(+)/B(-)	VT	Violet
QSSD	Safety Output	La	Emitted Light disengageable	GY	Grey
Signal	Signal Output	Mag	Magnet activation	WH	White
BI_D+/-	Ethernet Gigabit bidirect. data line (A-D)	RES	Input confirmation	PK	Pink
ENo RS422	Encoder 0-pulse 0/0 (TTL)	EDM	Contacting Monitoring	GNYE	Green/Yellow

Table 1

Detection Range	60 mm	120 mm
Light Spot Diameter	2,5 mm	5 mm

Switching Distance Deviation

Typical characteristic curve based on white, 90 % remission

HD11/HW11

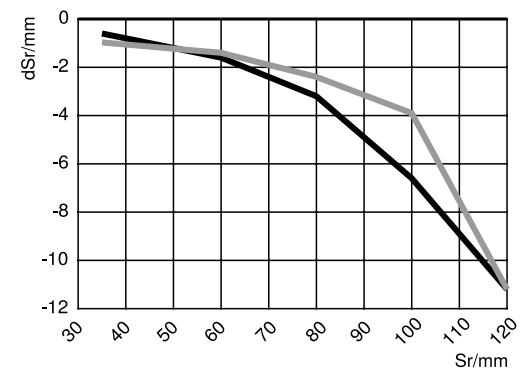

Sr = Switching Distance

dSr = Switching Distance Change

black 6 % remission

grey 18 % remission

