

Mounting Bracket for 54,5 × 27 × 16 mm (M) in Protective Housing

ZMW0M0001

Part Number

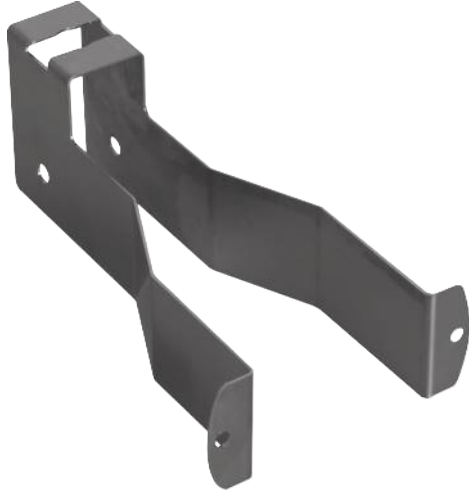

Technical Data

Mechanical Data

Material Aluminum

Packaging unit 1 Piece

Suitable Mounting Technology No.

510

- For 54,5 × 27 × 16 mm in protective housing

Complementary Products

Protective Housing ZSV-0x-01

