

# Operating Instructions

## **SR4B3B01S**

### **Safety Relay Basic Module**



EN



# Table of Contents

<b>1</b>	<b>Operating Instructions</b>	<b>3</b>
1.1	Function	3
1.2	Target Group	3
<b>2</b>	<b>Use for Intended Purpose</b>	<b>4</b>
<b>3</b>	<b>Safety precautions</b>	<b>5</b>
3.1	Safety Precautions	5
3.2	Warning Regarding Incorrect Use	5
3.3	Exclusion of Liability	5
3.4	General Information on the Product	5
<b>4</b>	<b>Technical Data</b>	<b>6</b>
4.1	General Data	6
4.2	Sensor Connection	8
4.3	Housing Dimensions	8
4.4	Control Panel	9
4.5	Complementary Products	9
<b>5</b>	<b>Installation and Electrical Connection</b>	<b>10</b>
5.1	Installation	10
5.2	Electrical Connection	10
5.3	Connection Example	10
<b>6</b>	<b>Initial Start-Up</b>	<b>11</b>
6.1	Settings	11
6.1.1	Opening the Front Cover	11
6.1.2	Cross-Circuit Monitoring	11
6.2	Configuration	12
6.2.1	Start Configuration	12
6.2.2	Sensor Configuration	12
6.2.3	Actuator Configuration	16
6.3	Function Test	16
<b>7</b>	<b>Maintenance Instructions</b>	<b>17</b>
<b>8</b>	<b>Removal</b>	<b>18</b>
<b>9</b>	<b>Proper Disposal</b>	<b>19</b>
<b>10</b>	<b>Declarations of Conformity</b>	<b>20</b>

# 1 Operating Instructions

## 1.1 Function

- These operating instructions provide the necessary information for installation, initial startup, safe operation and disassembly of the safety relay module.
- The operating instructions must always be kept in legible condition and made accessible.

## 1.2 Target Group

- All work described in these operating instructions may only be carried out by trained specialist personnel authorized by the plant operator.
- Only install and commission the device if you have read and understood the operating instructions and are familiar with applicable regulations on work safety and accident prevention.
- The selection and installation of the devices, as well as the integration of their controls, require the machine manufacturer to have qualified knowledge of relevant laws and normative requirements.

## 2 Use for Intended Purpose

### **Safety Relay Basic Module**

The safety relay modules for use in safety circuits are intended for installation in control cabinets. They are used for the safe evaluation of signals from positively driven position switches for safety functions or magnetic safety sensors on side-sliding, rotating and removable protective devices as well as emergency stop command devices and AOPDs (light barriers).

## 3 Safety precautions

### 3.1 Safety Precautions

- These instructions are an integral part of the product and must be kept on hand for the entire duration of its service life.
- Read the operating instructions carefully before using the product.
- Installation, initial start-up and maintenance of the product may only be carried out by qualified personnel.
- Tampering with or modifying the product is impermissible.
- Protect the product from contamination during initial start-up.
- The safety instructions given in the operating instructions must be followed, as must the country-specific installation requirements and regulations on safety and accident prevention.
- **The overall concept for the controller into which the safety component is incorporated must be validated in accordance with DIN EN ISO 13849-2.**

### 3.2 Warning Regarding Incorrect Use

- **If used improperly or for purposes other than those intended, or in the case of manipulation, use of the safety relay module may result in hazards to people and damage to the machine or system components.**
- **Please also note the information on this in standards ISO 14119 and EN ISO 13850.**

### 3.3 Exclusion of Liability

- No liability is assumed for damage and malfunction resulting from installation errors or non-observance of these operating instructions.
- The manufacturer assumes no further liability for damage resulting from the use of spare parts or accessories not approved by the manufacturer.
- No unauthorized repairs, modifications and alterations are permitted for reasons of safety. If carried out, the manufacturer assumes no liability for any resulting damage.
- The module is only to be operated in the closed housing, i.e., with the front cover mounted.

### 3.4 General Information on the Product

- The safety function is defined as the opening of releases 13-14, 23-24 and 33-34 when inputs S11-S12 and/or S21-S22 are opened.
- The safety-relevant current paths with output contacts 13-14, 23-24 and 33-34 meet the following requirements, taking the PFH value into account:
  - Category 4 – PL in accordance with EN ISO 13849-1
  - Complies with SIL 3 in accordance with IEC 61508 and EN 62061
- All relevant components must be considered in order to achieve the performance level (PL) from EN ISO 13849-1 for the overall safety function (e.g., sensor, logic, actuator).
- **The safety function, and thus conformity with the Machinery Directive, can only be maintained if the conversions described in these operating instructions are carried out correctly.**

## 4 Technical Data

### 4.1 General Data

Technical Data	
<b>Electrical Data</b>	
Temperature range	-25...60 °C
Storage temperature	-40...85 °C
Supply voltage	20.4...28.8 V DC 20.4...26.4 V AC
Input wiring	1-, 2-channel
Response time (automatic start)	Typ. 100 ms
Response time (monitored start)	Typ. 15 ms
Fall time (emergency stop)	Typ. 25 ms / max. 32 ms
Fall time (power failure)	Typ. 100 ms
Interruption during voltage drops	Typ. 80 ms
Clearances and creepage distances (EN 60664-1)	4 kV/2 (basic insulation)
Power consumption	Max. 2.0 W / 4.9 VA
Frequency range	50 Hz/60 Hz
Fuse	Internal electronic fuse, trip current > 500 mA, Internal electronic fuse, trip current > 50 mA (S11, S21), reset after interruption of supply voltage
Current and voltage at S11, S12, S21, S22	24 V DC, 10 mA
Current and voltage at X3	24 V DC / start pulse 35 mA/20 ms
Current and voltage at X2	24 V DC / start pulse 2.5 mA/25 ms
Utilization category (EN 60947-5-1)	AC-15: 230 V / 6 A DC-13: 24 V / 6 A
<b>Safety Output</b>	
Safety output	NO
Number of safety outputs, Stop 0	3
Safety output switching current, Stop 0 (250 V)	8 A ohmic (inductive with suitable protective circuit) Min. 10 V / 10 mA Total current at ambient temperature of up to 45 °C: 24 A; up to 55 °C: 18 A; up to 60 °C: 12 A
Safety output fuse, Stop 0	External ( $I_k = 1000$ A) in accordance with EN 60947-5-1 Fuse: 10 A fast, 8 A slow
<b>Auxiliary Output</b>	
Auxiliary output	NC
Number of auxiliary outputs	1
Auxiliary output switching current (24 V DC)	2 A
Auxiliary output fuse	External ( $I_k = 1000$ A) in accordance with EN 60947-5-1 Fuse: 2.5 A fast, 2 A slow
<b>Mechanical Data</b>	
Material	Plastic, glass-fiber reinforced

<b>Technical Data</b>	
Contact material	AgSnO, self-cleaning, positively driven
Mounting	Quick mount for standard rail DIN EN 60715
Degree of protection	IP20 (terminals), IP40 (housing), IP54 (mounting space)
Weight	240 g
Connection type	Pluggable screw terminal
Terminal tightening torque	0.6 Nm
Service life	10 million switching cycles
Clampable wire cross-section	0.25...2.5 mm <sup>2</sup>
Connection line	Rigid or flexible
Vibration resistance	10...55 Hz, amplitude: 0.35 mm
Shock resistance	10 g / 11 ms
<b>Technical Safety Data</b>	
Safety category (EN ISO 13849-1), Stop 0	Up to 4
Performance level (EN ISO 13849-1), Stop 0	To PL e
Safety integrity level (EN 61508), Stop 0	Up to SIL 3
Mission TM (EN ISO 13849-1)	20 a
Stop category (EN 60204-1)	Stop 0
Diagnostic coverage (DC)	99% (Stop 0)
PFH <sub>D</sub>	≤ 2,00 × 10 <sup>-8</sup> /h
Common cause failure (CCF)	> 65 points
B10d switching cycles, mechanical (20% load)	20,000,000
B10d switching cycles (40% load)	7,500,000
B10d switching cycles (60% load)	2,500,000
B10d switching cycles (80% load)	1,000,000
B10d switching cycles (100% load)	400,000
<b>Function</b>	
Cross-circuit detection	Optional
Wire break detection	Yes
Ground fault detection	Yes
Start, monitored	Yes
Start, automatic	Yes
Contactors monitoring	Yes
NC input signal	Yes
OSSD input signal	Yes

## 4.2 Sensor Connection

19

PIN	Function	In/Out
A1	+24 V DC/24 V AC	
A2	0 V DC/24 V AC	
S11-S12	Input Channel 1 (+)	In
S21-S22	Input Channel 2 (+)	In
S21-S22	Input Channel 2 (-) with Wire Breakage Detection	In
13-14	Safety Enabling Circuit 1	Out
23-24	Safety Enabling Circuit 2	Out
33-34	Safety Enabling Circuit 3	Out
41-42	Auxiliary Contact	Out
S12-X2	Feedback Circuit/Reset	
S12-X3	Feedback Circuit/Autostart	

## 4.3 Housing Dimensions

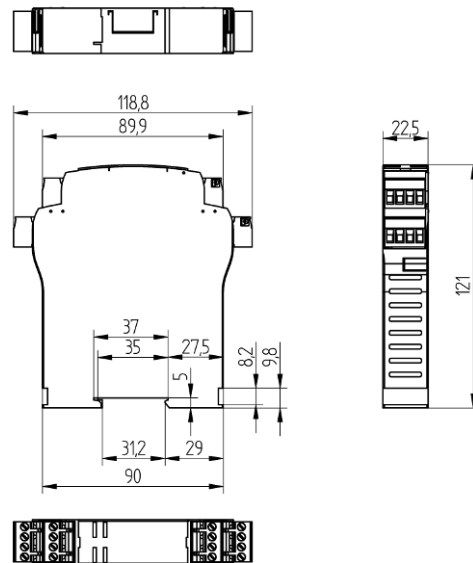

Dimensions specified in mm (1 mm = 0.03937")

## 4.4 Control Panel

SR1

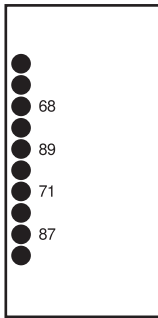

---

68 = supply voltage (LED illuminates when operating voltage is applied to terminals A1–A2)

89 = internal operating voltage (LED illuminates when operating voltage is applied to terminals A1-A2 and the fuse has not tripped.)

71 = channel 1

87 = channel 2

47 = cross-circuit detection

---

## 4.5 Complementary Products

wenglor offers you the right connection and mounting technology as well as other accessories for your product. You can find this at [www.wenglor.com](http://www.wenglor.com) on the product details page at the bottom.

# 5 Installation and Electrical Connection

## 5.1 Installation

## 5.2 Electrical Connection

Electrical connection is only permissible in a de-energized state and must be carried out by authorized, trained personnel.

With regard to electrical safety, the contact protection for connected and electrically interconnected equipment, as well as the insulation for supply lines, must be designed for the highest voltage occurring on the device.

To avoid EMC disturbances, the physical environment and operating conditions at the product's installation location must comply with the electromagnetic compatibility (EMC) section of DIN EN 60204-1.

## 5.3 Connection Example

Two-channel control, shown on example protective door monitoring system with two position switches, of which one contact is positively driven; with external reset button R

- Power level: Two-channel control, suitable for contact reinforcement or contact multiplication by means of contactors or relays with positively driven contacts.
- The controller detects wire breaks, ground faults and cross-circuits in the monitoring circuit.

a) Control logic

(R) Reset button

(H2) Feedback loop

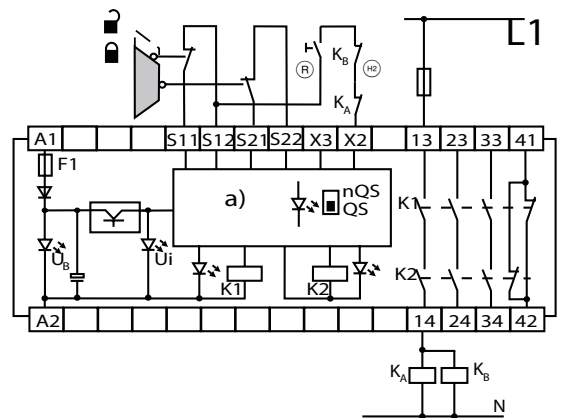

## 6 Initial Start-Up

### 6.1 Settings

#### 6.1.1 Opening the Front Cover

- The front cover is opened by inserting a slotted screwdriver into the upper and lower cover recess and lifting slightly.
- The ESD requirements must be met when the front cover is open.
- Once the adjustment has been made, the front cover must be reinstalled.
- The off-delay set must be recorded on the front cover.
- **Only touch components after they have been discharged!**

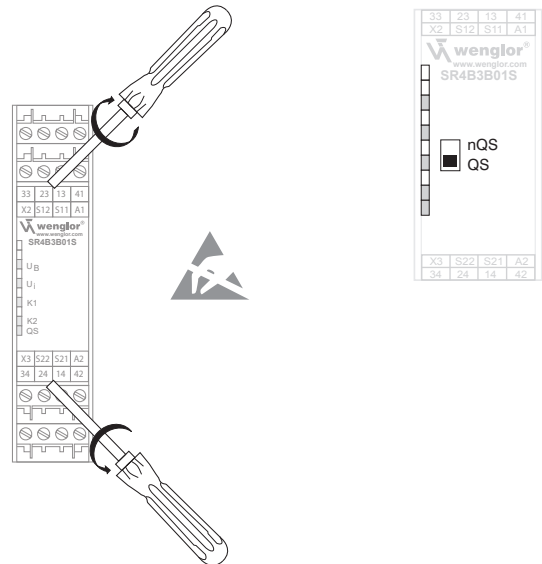

#### 6.1.2 Cross-Circuit Monitoring

- The cross-circuit monitoring function (as-delivered condition) is programmed using switch S1 under the front cover of the module.
- The switch may only be operated when it is de-energized using a finger or a blunt, insulated tool.

##### **Pos. nQS (top), not cross-circuit proof**

- Suitable for single-channel applications and applications with non-floating outputs in the control circuits

##### **Pos. QS (bottom), cross-circuit-proof**

- Suitable for two-channel applications without non-floating outputs in the control circuits

## 6.2 Configuration

### 6.2.1 Start Configuration

#### External reset button (monitored start)

- The external reset button is connected in series to the feedback loop.
- The module is activated by resetting (after releasing) the reset button (= detection of falling edge).
- Error in reset button, e.g., welded contact or manipulations that may lead to unintentional restart have been detected in this circuit, resulting in operational interruption.

Ⓡ Reset button

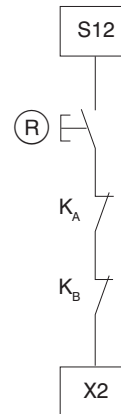

#### Automatic start

- Automatic start is programmed by connecting the feedback circuit to terminals S12-X3.
- If the feedback loop is not required, replace it with a bridge.
- **ATTENTION: Not permissible without additional measures if there is a risk people will step behind!**
- If module SR4B3B01S is used in the “automatic start” operating mode, the higher-level control must prevent automatic restart after emergency shutdown in accordance with EN 60204-1, Section 9.2.3.4.2.

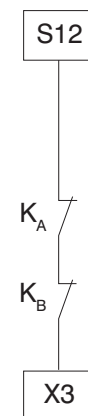

### 6.2.2 Sensor Configuration

#### Single-channel emergency stop circuit with command devices in accordance with DIN EN ISO 13850 (EN 418) and EN 60947-5-5

- The controller detects a wire break and ground fault in the control circuit.
- Cat. 1 – PL c from EN ISO 13849-1 can be achieved.

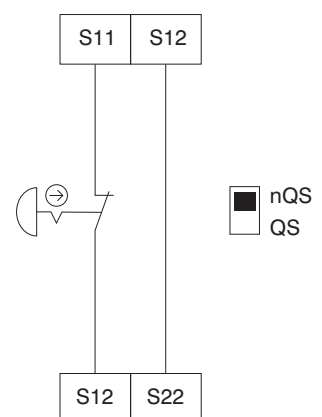

**Two-channel emergency stop circuit with command devices in accordance with DIN EN ISO 13850 (EN 418) and EN 60947-5-5**

- The controller detects a wire break and ground fault in the control circuit.
- Cross-circuits between the control circuits are not detected.
- Cat. 4 – PL e from EN ISO 13849-1 can be achieved (with protected cable routing).

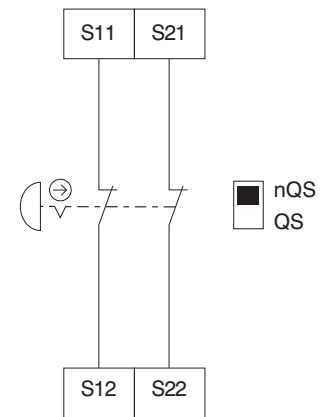

**Two-channel emergency stop circuit with command devices in accordance with DIN EN ISO 13850 (EN 418) and EN 60947-5-5**

- The controller detects a wire break and ground fault in the control circuits.
- Cross-circuits between the control circuits are detected.
- Cat. 4 – PL e from EN ISO 13849-1 can be achieved.

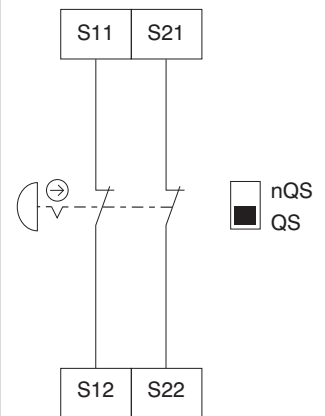

**Single-channel protective door monitoring circuit with interlocking devices in accordance with ISO 14119**

- At least one positively driven contact required.
- The controller detects a wire break and ground fault in the control circuit.
- Cat. 1 – PL c from EN ISO 13849-1 can be achieved.

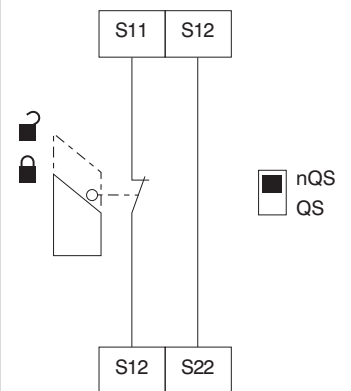

**Two-channel protective door monitoring circuit with interlocking devices in accordance with ISO 14119**

- At least one positively driven contact required.
- The controller detects wire breaks and ground faults in the control circuits.
- Cross-circuits between the door monitoring circuits are not detected.
- Cat. 4 – PL e from EN ISO 13849-1 can be achieved (with protected cable routing).

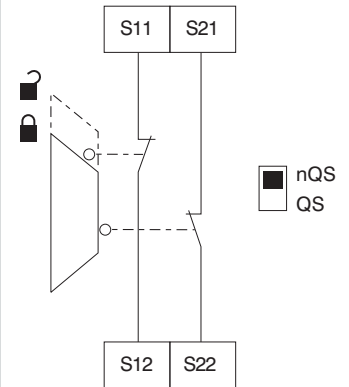

**Two-channel protective door monitoring circuit with interlocking devices in accordance with ISO 14119**

- At least one positively driven contact required.
- The controller detects a wire break and ground fault in the control circuit.
- Cross-circuits between the door monitoring circuits are detected.
- Cat. 4 – PL e from EN ISO 13849-1 can be achieved.

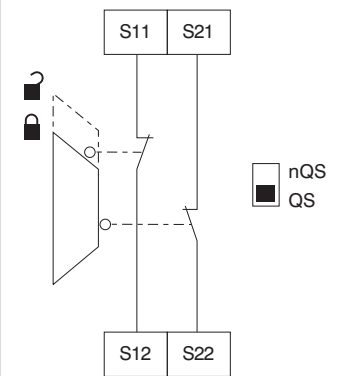

**Two-channel control for safety-related electronic (microprocessor-based) protection device with P-switching semiconductor outputs (e.g., AOPDs) in accordance with EN IEC 61496**

- The controller detects wire breaks and ground faults in the control circuits.
- Cross-circuits between the control circuits are usually detected by the protective device. The module therefore does not have cross-circuit detection here.
- If cross-circuits are detected in the control circuits by the protective device: Cat. 4 – PL e from EN ISO 13849-1 can be achieved.

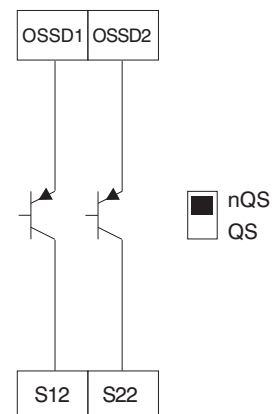

### Two-channel control for safety solenoid switches in accordance with EN 60947-5-3

- The controller detects wire breaks and ground faults in the control circuits.
- Cross-circuits between the control circuits are not detected.
- Cat. 3 – PL e from EN ISO 13849-1 can be achieved.

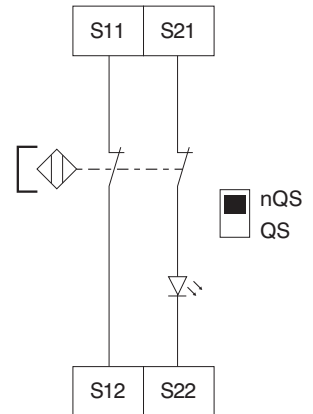

### Two-channel control for safety solenoid switches in accordance with EN 60947-5-3

- The controller detects wire breaks and ground faults in the control circuits.
- Cross-circuits between the control circuits are detected.
- Cat. 4 – PL e from EN ISO 13849-1 can be achieved.

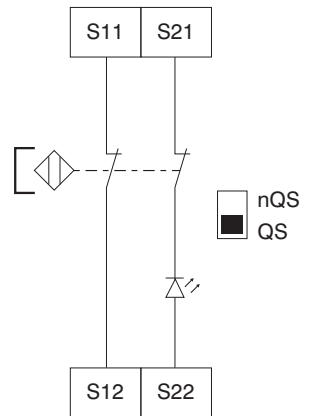

**It is only permitted to connect safety solenoid switches to evaluation circuit SR4B3B01S if the requirements of standard EN 60947-5-3 have been met.**

**The following minimum requirements regarding the technical data must be met:**

- **Switching capacity: min. 240 mW**
- **Switching voltage: min. 24 V DC**
- **Switching current: min. 10 mA**

When connecting sensors with LEDs in the control circuit (protective circuit), make sure that the following rated operating voltage is maintained:

- 24 V DC with max. tolerance of -5%/+20%
- 24 V AC with max. tolerance of -5%/+10%

Availability problems may otherwise occur, especially when sensors are connected in series and there is a voltage drop in the control circuit, e.g., caused by LEDs.

## 6.2.3 Actuator Configuration

### Single-channel control

- Suitable for contact reinforcement or contact multiplication by means of contactors or relays with positively driven contacts.
- If the feedback loop is not required, replace it with a bridge.
-  = Feedback loop and reset button in series

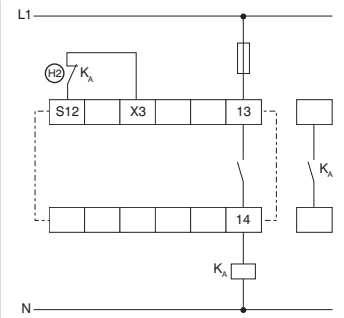

### Two-channel control with feedback loop

- Suitable for contact reinforcement or contact multiplication by means of contactors or relays with positively driven contacts.
- If the feedback loop is not required, replace it with a bridge.
-  = Feedback loop and reset button in series

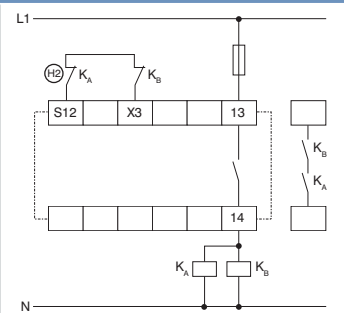

## 6.3 Function Test

The safety function of the safety relay must be tested. The following must be ensured in advance:

- Tight fit
- Cables must be correctly routed and connected
- Check safety relay module housing for damage
- Check electrical function of connected sensors and their effect on safety relay module and downstream actuators

# 7 Maintenance Instructions

We recommend performing a visual inspection and a function test at regular intervals including the following steps:

- Check safety relay for secure fit
- Check supply line for damage
- Check electrical connection

**The device must be included in the regular inspections in accordance with the Industrial Safety Regulation (BetrSichV), however, at least 1× annually.**

**Damaged or defective devices must be replaced.**

## 8 Removal

The safety relay module may only be removed in a de-energized state.  
Press the bottom of the housing upward and unhook it by tilting slightly forward.

## 9 Proper Disposal

wenglor sensoric GmbH does not accept the return of unusable or irreparable products. Respectively valid national waste disposal regulations apply to product disposal.

# 10 Declarations of Conformity

Declarations of conformity can be found on our website at [www.wenglor.com](http://www.wenglor.com) in the product's separate download area.

## EU Konformitätserklärung EU Declaration of Conformity (DoC)



Name und Anschrift des Herstellers / Name and address of manufacturer:

wenglor sensoric GmbH  
wenglor Straße 3  
88069 Tett nang / GERMANY  
Phone: +49 7542 5399 0  
Email: [info@wenglor.com](mailto:info@wenglor.com)

Diese Erklärung gilt für die folgenden Produkte: This declaration applies to the following products:

### SR4B3B01S

Wir bestätigen die Übereinstimmung mit den grundlegenden Anforderungen der Europäischen Richtlinien

We confirm compliance with the essential requirements of the European Directives

Richtlinie / Directive

EMV / EMC 2014/30/EU

Maschinen / MD 2006/42/EG

Fundstelle / Reference

Amtsblatt / Office Journal L96 29.03.2014

Amtsblatt / Office Journal L157 9.06.2006

Folgende harmonisierte Normen wurden angewandt:

EN 60947-5-1:2017+AC:2020  
EN 60947-5-3:2013

The following harmonized standards have been used:

EN ISO 13849-1:2015 (Cat. 4, PL e)

Produkt-Beschreibung

Sicherheits-Relais  
Sicherheits-Bauteil nach 2006/42/EG Anhang IV  
Seriennummer: Lt. Typenschild

Benannte Stelle / Zertifikat Nr.

TÜV Rheinland Industrie Service GmbH  
Am Grauen Stein  
51105 Köln

Product description

Safety Relay  
Safety component per 2006/42/EC annex IV  
Serial Number: See rating plate

Notified Body / Certificate No.

NB No. 0035  
Reg.No. 01/205/5289.02/23

EU Konformitätserklärung  
EU Declaration of Conformity (DoC)



Klaus Epple ist bevollmächtigt, die technischen Unterlagen zusammenzustellen.

Klaus Epple is authorized to compile the technical documentation.

Diese Erklärung stellvertretend für den Hersteller wird abgegeben durch:

On account of the manufacturer, this declaration is given by:

Dipl.-Ing. ETH Rafael Baur  
Geschäftsführender Gesellschafter / Owner and General Manager  
Email: rafael.baur@wenglor.com

Tettnang, 31/07/2023  
Place Date

*R. Baur*  
Signature



wenglor sensoric GmbH · wenglor Straße 3 · 88069 Tettnang · GERMANY · www.wenglor.com



Precisely Right.

	UL-Ratings:	Main-Output
	US LISTED 382E	230VAC / 8A
	IND.CONTEQ.	24VDC / 8A
	Use Copper Conductors Only, Use 60°C / 75°C Conductors	B300, R300
Use No. 28-12 AWG Wire Size Only, Tightening Torque 5 lb in.		