



## Index

<b>1. Operating instructions</b>	<b>3</b>
1.1. Function	3
1.2. Target group	3
<b>2. Proper Use</b>	<b>3</b>
<b>3. Product description</b>	<b>3</b>
<b>4. Safety Precautions</b>	<b>4</b>
<b>6. Technical Data</b>	<b>4</b>
6.1. Connection	6
6.2. Housing dimensions	6
<b>7. Mounting instructions</b>	<b>8</b>
<b>8. Test information</b>	<b>10</b>
8.1. Test during commissioning	10
8.2. Regular test	10
8.3. Functional test	10
<b>9. Dismantling</b>	<b>11</b>
<b>10. Proper Disposal</b>	<b>11</b>
<b>11. EU Declaration of Conformity</b>	<b>11</b>

# 1. Operating instructions

## 1.1. Function

- These operating instructions provide the information needed for the installation, commissioning, safe operation and the dismantling of the emergency stop switches.
- The operating instructions must be stored so as to ensure that they are legible and accessible at all times.

## 1.2. Target group

- All actions described in these operating instructions may only be carried out by trained specialist personnel that has been authorised by the system operator.
- Only install and commission the device after you have read and understood the operating instructions and if you are familiar with the applicable occupational health and accident prevention rules and regulations.
- For the selection and installation of the devices and their connection to the control system qualified knowledge of all applicable laws and the standard requirements defined by the machine manufacturer are needed.

# 2. Proper Use

This wenglor product has to be used according to the following functional principle:

## Emergency stop switch

E-stops/emergency switch-off devices are electromechanical switch components serving to protect persons working with machinery or close to it. They are used to stop or switch off machinery and equipment in order to avert impending or minimise existing dangers to persons or damages on machines/material.

For the application of E-stops /emergency switch-off devices as directed the respective requirements for installation and operation must be observed:

EN 60204-1

EN ISO 13849-1

EN ISO 13850

Contact blocks are suitable for applications up to PL e per EN ISO 13849-1 and up to SIL CL 3 per EN 62061.

# 3. Product description

The emergency stop switches consist of different variants of actuators and contact blocks. The contact blocks are equipped with a failure protection monitoring the connection between the actuator and the contact block. If the connection is interrupted, the contact opens and triggers the emergency stop function. It is actuated by pushing and unlocked by turning in either direction.

## 4. Safety Precautions

- This operating instruction is part of the product and must be kept during its entire service life.
- Read this operating instruction carefully before using the product.
- Installation, start-up and maintenance of this product has only to be carried out by trained personnel.
- Tampering with or modifying the product is not permissible.
- Protect the product against contamination during start-up.

### CAUTION!

- Disconnect equipment and device from the mains before installation.
- E-stops/emergency switch-off devices fulfil the function of personal protection. Improper installation or unauthorized modifications may lead to severe personal injuries.
- E-stops/emergency switch-off devices should not be bypassed, removed or otherwise disabled.
- The switching operation may only be triggered by suitable actuators which are securely connected to the contactor.
- Use suitable connections for the contact blocks.
- Improper installation or tampering may result in machine and material damages.
- The E-stop/emergency switch-off function should not replace the applicable safety precautions or other safety functions but should rather be used as a back-up safeguarding measure.
- The E-stop/emergency switch-off function should not impair the effectiveness of other safety devices or equipment with other safety functions.
- Based on his hazard analysis the design engineer must ensure that in combination with the control system the E-stop/emergency switch-off device meets the required safety category.
- Note regarding the use of protective shrouds: The user must check for accessibility.



## 5. Approvals



## 6. Technical Data

### Actuator

Storage temperature	-50...85 °C
Housing material	Plastic
Mounting Mode	Mounting
Installation opening	22,3 mm

Unlocking	turning
Tightening torque	≤ 2,5 Nm
Service Life (mechanical)	50 000 switching cycles
Switch position indication	yes
Overload protection according to EN ISO 13850	yes

Order No.	SEAN01	SEAP01	SEAL01	SEAC01
Temperature Range	-30...70 °C		-30...55 °C	-30...70 °C
Protection class	IP65, IP67, IP69K		IP65	IP65, IP69K
Anti-blocking sleeve	—	✓	✓	—
Protective collar	—	—	—	✓
Illumination	—	—	✓	—
Applicable terminal block	SC20101S SC21101S	SC20101S SC21101S	SC20J01S SC21J01S	SC20101S SC21101S

### Terminal block

Storage temperature	-50...85 °C
Service Life (nominal load)	20 000 Switching Cycles
Switching Current	< 1 mA
Rated insulation voltage U <sub>i</sub>	250 V
Contact material	AgNi
Bounce time	> 10 ms
Line cross-section	2,5 mm <sup>2</sup>
Service Life (mechanical)	20 000 Switching Cycles
Utilisation category	AC15/DC13
Rated insulation voltage U <sub>e</sub> (Rated operating current I <sub>e</sub> )	250 V AC (3 A) 24 V DC (2 A)
Switching capacity	AC:10 I <sub>e</sub> /DC: 1,1 I <sub>e</sub>
Connection	Screwed connection
Switching Cycles B10d	104 000
Stroke	6 mm
Defect protection	yes

Order Number	SC20101S	SC21101S	SC20J01S	SC21J01S
Rated impulse withstand voltage U <sub>imp</sub>	2,5 kV			
Protection class	IP20			
Pollution degree	3			
Short circuit means (recommendation)	SCPD 16 A, Char. C			
Conditional short circuit current I <sub>q</sub>	1000 A			
Temperature Range	-30...85 °C		-30...70 °C	
Positively driven NC contact	2			
NO	0	1	0	1
Lighting module	—		✓	
Connection Diagram	P06	P07	P08	P09

## 6.1. Connection

P06

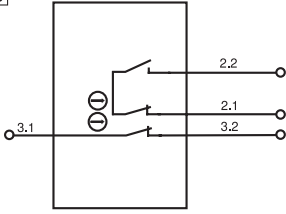

P08

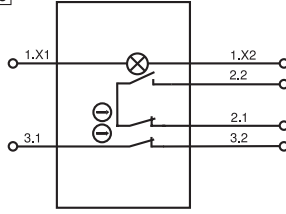

P07

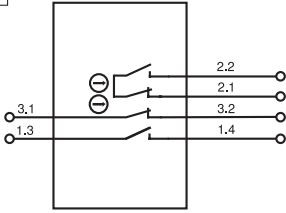

P09

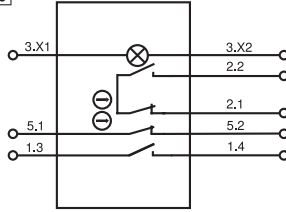

## 6.2. Housing dimensions

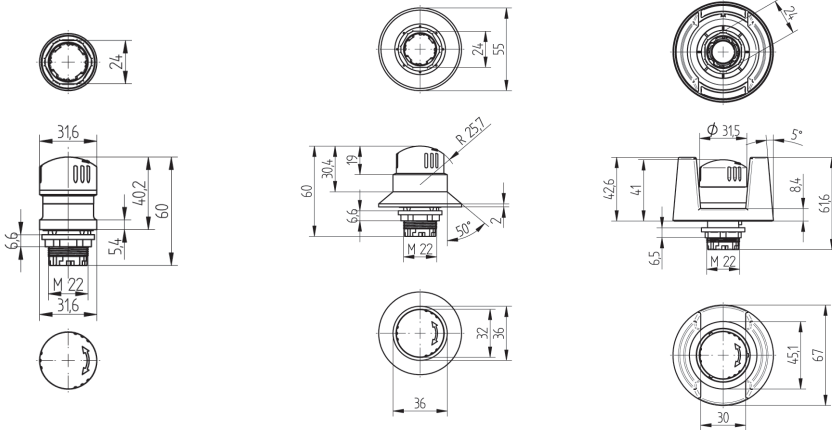

SEAN01

SEAP01

SEAC01

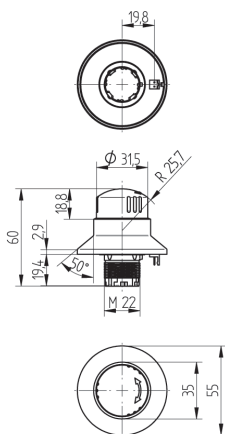

SEAL01

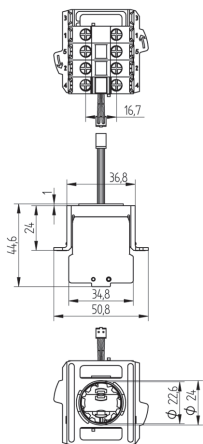

SC21J01S

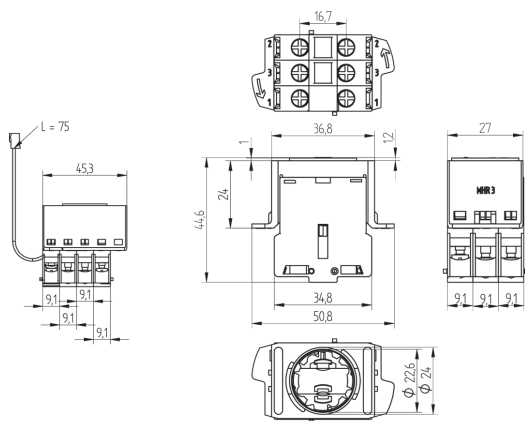

SC21I01S

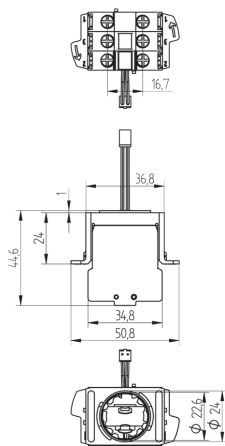

SC20J01S

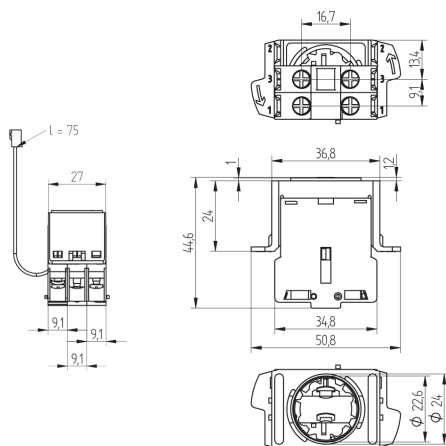

SC20I01S

## Complementary Products (see catalog)

wenglor offers Connection Technology for field wiring.

Installation Tool Z0046

SR4 safety relay

## 7. Mounting instructions

- During operation of the Sensors, the corresponding electrical and mechanical regulations, as well as safety regulations must be observed.
- The Sensor must be protected from mechanical impact.
- The product is to be fastened so that the installation position cannot change.
- During assembly, easy accessibility of the emergency stop switch has to be ensured.

	SEAN01, SEAP01, SEAC01 + SC20I01S, SC21I01S	SEAL01 + SC20J01S, SC21J01S
1		
2		
3		

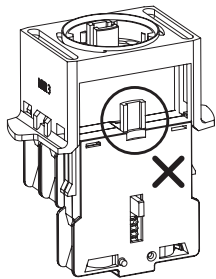
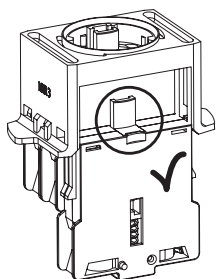
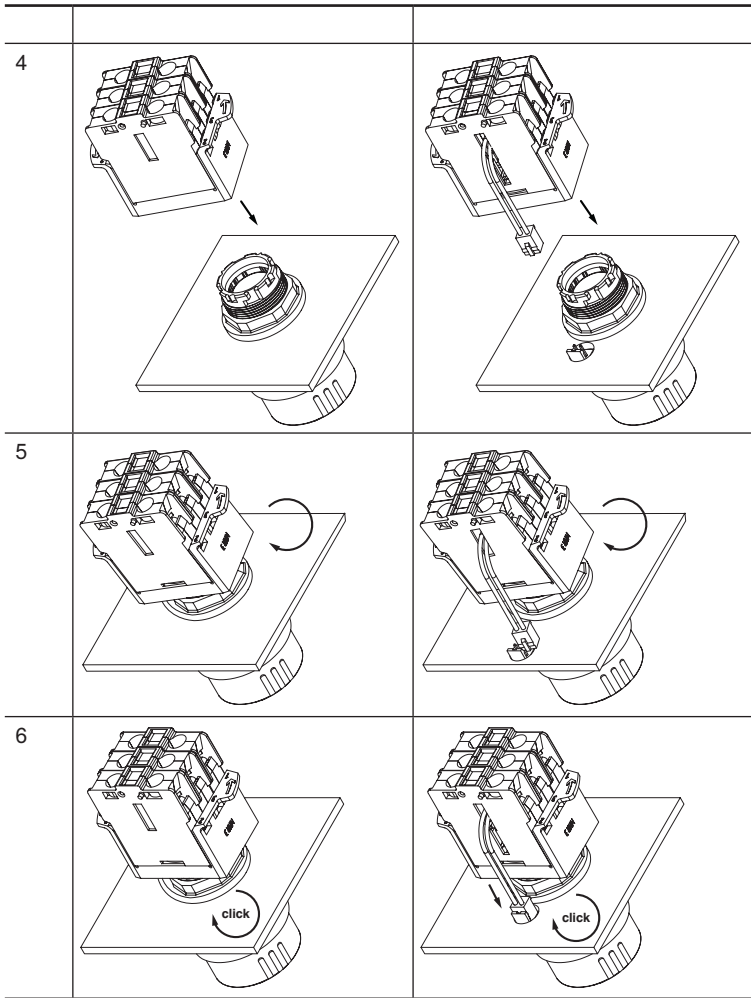

## 8. Test information

The following national and international statutory provisions apply to installation, commissioning and regular technical inspections:

- Directive 2006/42/EG
- Low-Voltage Directive 2014/35/EU
- Safety Regulations as well as
- Regulations of the Accident Prevention/Safety Rules

### 8.1. Test during commissioning

- Functional test (see corresponding section)

### 8.2. Regular test

Based on his risk assessment, the machine designer has to determine the inspection interval. It is, however, recommended that the competent safety officer activates and tests the E-stop or switch-off device at least once a year to ensure its proper functioning.

Test:

- no visible unauthorized modifications or damages
- secure mounting
- no loose connections
- Functional test (see corresponding section)

### 8.3. Functional test

Mechanical Test:

- Actuator is fastened protected against twisting
- Lock nut is tightened so that there is no play in longitudinal direction
- Actuator and contact block are properly engaged.
- E-stop/switch-off device latches when operated

Electrical Test:

- Start the machine and push the actuator
- Machine stops/switches off



### **Incident Management**

- Mechanical overload or external impact damage may impair the function of the E-stop/switch-off device.
- Functional test (see corresponding section)

**No operation with unknown malfunction!**

## **9. Dismantling**

Only dismantle the emergency stop switch when de-energized.

## **10. Proper Disposal**

wenglor sensoric GmbH does not accept the return of unusable or irreparable products. Respectively valid national waste disposal regulations apply to product disposal.

## **11. EU Declaration of Conformity**

The EU Declaration of Conformity can be found on our homepage at [www.wenglor.com](http://www.wenglor.com) in the download area for the product.

Translation of the Original Operating Instruction.  
Subject to change without notice.