

# Retro-Reflex Sensor for Transparent Objects

## P1NK205

Part Number



- Dynamic readjustment of the switching threshold
- High-end
- Innovative display unit for alignment and diagnosis
- Special for glass, PET and films
- Wireless settings via NFC

The retro-reflex sensor for clear glass recognition works with red light and a reflector. It has a IO-Link interface with a data storage function as well as additional configuration and diagnostic options. The interface can also be used to configure the sensors (PNP/NPN, NC/NO, switching distance, error output), as well as for reading out switching statuses and signal values. The dynamic readjustment of the switching threshold function automatically adjusts this for contamination, aging or temperature deviations, meaning that these factors have almost no effect on functionality.

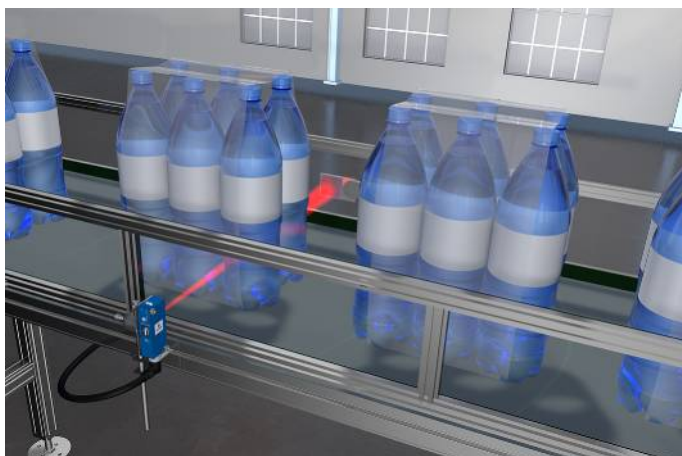

### Technical Data

Optical Data	
Range	3500 mm
Reference Reflector/Reflector Foil	RQ100BA
Clear Glass Recognition	yes
Smallest Recognizable Part	see Table 2
Switching Hysteresis	< 5 %
Light Source	Red Light
Polarization Filter	yes
Service Life (T = +25 °C)	100000 h
Max. Ambient Light	10000 Lux
Light Spot Diameter	see Table 1
Single-Lens Optic	yes
Electrical Data	
Supply Voltage	15...30 V DC
Supply Voltage with IO-Link	18...30 V DC
Current Consumption (U <sub>b</sub> = 24 V)	< 20 mA
Switching Frequency	1000 Hz
Switching frequency (speed mode)	2000 Hz
Response Time	0,5 ms
Response time (speed mode)	0,25 ms
Temperature Drift	< 3 %
Temperature Range	-40...60 °C
Switching Output Voltage Drop	< 2 V
Switching Output/Switching Current	100 mA
Residual Current Switching Output	< 50 µA
Short Circuit Protection	yes
Reverse Polarity Protection	yes
Overload Protection	yes
Lockable	yes
Teach Mode	NT, MT
Interface	IO-Link V1.1
Data Storage	yes
Protection Class	III
Mechanical Data	
Setting Method	Teach-in/NFC
Housing Material	Plastic
Degree of Protection	IP67/IP68
Connection	M12 × 1; 4-pin
Optic Cover	PMMA
Safety-relevant Data	
MTTFd (EN ISO 13849-1)	1764,37 a
IO-Link	●
PNP NO	●
NFC interface	●
Connection Diagram No.	221
Control Panel No.	A30
Suitable Connection Equipment No.	2
Suitable Mounting Technology No.	350

### Complementary Products

Dust Extraction Tube STAUBTUBUS-03
IO-Link Master
Reflector, Reflector Foil
Set Protective Housing Z1NS001
Software

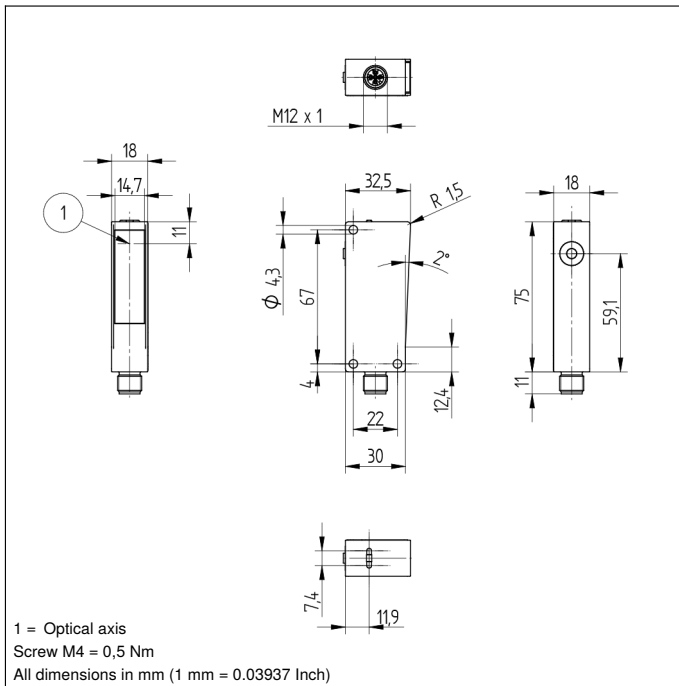

### Ctrl. Panel

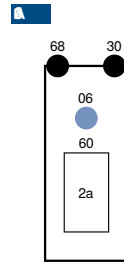

- 06 = Teach Button
- 2a = NFC interface
- 30 = Switching Status/Contamination Warning
- 60 = display
- 68 = supply voltage indicator

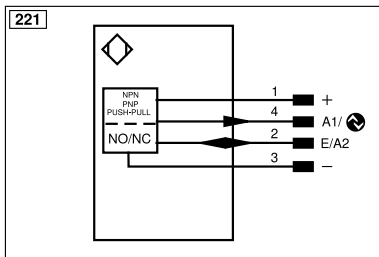

Legend					
+	Supply Voltage +	nc	Not connected	ENBRS422	Encoder B/B (TTL)
-	Supply Voltage 0 V	U	Test Input	ENA	Encoder A
~	Supply Voltage (AC Voltage)	Ü	Test Input inverted	ENb	Encoder B
A	Switching Output (NO)	W	Trigger Input	AMIN	Digital output MIN
Ā	Switching Output (NC)	W-	Ground for the Trigger Input	AMAX	Digital output MAX
V	Contamination/Error Output (NO)	O	Analog Output	AOK	Digital output OK
ȳ	Contamination/Error Output (NC)	O-	Ground for the Analog Output	SY In	Synchronization In
E	Input (analog or digital)	BZ	Block Discharge	SY OUT	Synchronization OUT
T	Teach Input	Amv	Valve Output	OLT	Brightness output
Z	Time Delay (activation)	a	Valve Control Output +	M	Maintenance
S	Shielding	b	Valve Control Output 0 V	rsv	Reserved
RxD	Interface Receive Path	SY	Synchronization	Wire Colors according to DIN IEC 60757	
TxD	Interface Send Path	SY-	Ground for the Synchronization	BK	Black
RDY	Ready	E+	Receiver-Line	BN	Brown
GND	Ground	S+	Emitter-Line	RD	Red
CL	Clock	±	Grounding	OG	Orange
E/A	Output/Input programmable	SnR	Switching Distance Reduction	YE	Yellow
IO-Link	IO-Link	Rx+/-	Ethernet Receive Path	GN	Green
PoE	Power over Ethernet	Tx+/-	Ethernet Send Path	BU	Blue
IN	Safety Input	Bus	Interfaces-Bus A(+)/B(-)	VT	Violet
OSSD	Safety Output	La	Emitted Light disengageable	GY	Grey
Signal	Signal Output	Mag	Magnet activation	WH	White
BI_D+/-	Ethernet Gigabit bidirect. data line (A-D)	RES	Input confirmation	PK	Pink
ENo RS422	Encoder 0-pulse 0/0 (TTL)	EDM	Contact Monitoring	GNYE	Green/Yellow
PT	Platinum measuring resistor	ENAR5422	Encoder A/A (TTL)		

**Table 1**

Working Distance	0,3 m	1,7 m	3,5 m
Light Spot Diameter	20 mm	55 mm	110 mm

**Table 2**

Distance, Sensor to Reflector	0,3 m	1,7 m	3,5 m
Smallest Recognizable Part	1 mm	5 mm	10 mm

### Feasible reflector distance

Reflector type, mounting distance

RQ100BA	0...3,5 m	RR21_M	0...0,7 m
RE18040BA	0...2,5 m	Z90R004	0...1,3 m
RQ84BA	0...3 m	Z90R005	0...1,5 m
RR84BA	0...3,5	ZRAE02B01	0...1,5 m
RE9538BA	0...1,4 m	ZRME01B01	0...0,35 m
RE6151BM	0...2,8 m	ZRME03B01	0...1,5 m
RR50_A	0...2,5 m	ZRMR02K01	0...1,5 m
RE6040BA	0...2,8 m	ZRMS02_01	0...0,7 m
RE8222BA	0...1,6 m	RF508	0...0,7 m
RR34_M	0...1,8 m	RF258	0...0,7 m
RE3220BM	0...1,1 m	ZRDF_K01	0...2,2 m
RE6210BM	0...0,8 m	Z91R001	0...1,5 m
RR25_M	0...1 m	ZRDF10K01	0...2,4 m
RR25KP	0...0,5 m		

