

P1NHxxx

Reflex Sensors with Background Suppression
High-End with Teach-in



Operating Instructions

Table of Contents

1. General	3
1.1 Information Concerning these Instructions	3
1.2 Explanations of Symbols	3
1.3 Limitation of Liability	4
1.4 Copyrights	4
2. For Your Safety	5
2.1 Use for Intended Purpose	5
2.2 Use for Other than the Intended Purpose	5
2.3 Personnel Qualifications	6
2.4 Modification of Products	6
2.5 General Safety Precautions	6
2.6 Laser/LED Warnings	6
2.7 Approvals and protection class	6
3. Technical Data	7
3.1 Spot Diameter	8
3.2 Switching Frequency / Response Time	8
3.2.1 Switching Distance Deviation	9
3.3 Complementary Products	10
3.4 Layout	10
3.5 Control Panel	12
3.6 Scope of Delivery	12
4. Transport and Storage	13
4.1 Transport	13
4.2 Storage	13
5. Installation and Electrical Connection	13
5.1 Installation	13
5.2 Electrical Connection	14
5.3 Diagnostics	15
6. Settings	16
7. Functions Overview	16
7.1 Teach Mode	16
7.1.1 Foreground Teach-In	16
7.1.2 Background Teach-In	17
7.2 Pin Function, I/O2	17
7.2.1 Input External Teach-In	17
7.2.2 Error Output	18
7.3 Additional functions and settings	18
8. IO-Link	18
9. NFC	19
10. Maintenance Instructions	19
11. Proper Disposal	20
12. Appendix	20
12.1 List of Abbreviations	20
12.2 Change Index, Operating Instructions	20
12.3 EU Declaration of Conformity	20

1. General

1.1 Information Concerning these Instructions

- These instructions apply to the products with ID code P1NHxxx.
- They make it possible to use the product safely and efficiently.
- These instructions are an integral part of the product and must be kept on hand for the entire duration of its service life.
- Local accident prevention regulations and national work safety regulations must be complied with as well.
- The product is subject to further technical development, and thus the information contained in these operating instructions may also be subject to change. The current version can be found at www.wenglor.com in the product's separate download area.



NOTE!

The operating instructions must be read carefully before using the product and must be kept on hand for later reference.

1.2 Explanations of Symbols

- Safety precautions and warnings are emphasized by means of symbols and attention-getting words.
- Safe use of the product is only possible if these safety precautions and warnings are adhered to.

The safety precautions and warnings are laid out in accordance with the following principle:



Attention-Getting Word! Type and Source of Danger!

Possible consequences in the event that the hazard is disregarded.

- Measures for averting the hazard.

The meanings of the attention-getting words, as well as the scope of the associated hazards, are listed below.



DANGER!

This word indicates a hazard with a high degree of risk which, if not avoided, results in death or severe injury.



WARNING!

This word indicates a hazard with a medium degree of risk which, if not avoided, may result in death or severe injury.



CAUTION!

This word indicates a hazard with a low degree of risk which, if not avoided, may result in minor or moderate injury.



ATTENTION!

This word draws attention to a potentially hazardous situation which, if not avoided, may result in property damage.



NOTE!

A note draws attention to useful tips and suggestions, as well as information regarding efficient, error-free use.

1.3 Limitation of Liability

- The product has been developed in consideration of the current state-of-the-art and applicable standards and guidelines. Subject to change without notice.
- A valid declaration of conformity can be accessed at www.wenglor.com in the product's separate download area.
- wenglor sensoric elektronische Geräte GmbH (hereinafter referred to as "wenglor") excludes all liability in the event of:
 - Non-compliance with the instructions
 - Use of the product for purposes other than those intended
 - Use by untrained personnel
 - Use of unapproved replacement parts
 - Unapproved modification of products
- These operating instructions do not include any guarantees from wenglor with regard to the described procedures or specific product characteristics.
- wenglor assumes no liability for printing errors or other inaccuracies contained in these operating instructions, unless wenglor was verifiably aware of such errors at the point in time at which the operating instructions were prepared.

1.4 Copyrights

- The contents of these instructions are protected by copyright law.
- All rights are reserved by wenglor.
- Commercial reproduction or any other commercial use of the provided content and information, in particular graphics and images, is not permitted without previous written consent from wenglor.

2. For Your Safety

2.1 Use for Intended Purpose

The product is based on the following functional principle:

Reflex Sensors with Background Suppression

Reflex sensors with background suppression analyze the light reflected from objects. As these sensors work according to the principle of angular measurement, the color, shape and surface characteristics of the object have almost no influence on the detection range. Even dark objects can be reliably detected against a bright background. The output is switched as soon as an object passes the selected range.

This product can be used in the following industry sectors:

- Special machinery manufacturing
- Heavy machinery manufacturing
- Logistics
- Automotive industry
- Food industry
- Packaging industry
- Pharmaceuticals industry
- Plastics industry
- Woodworking industry
- Consumer goods industry
- Paper industry
- Electronics industry
- Glass industry
- Steel industry
- Aviation industry
- Chemicals industry
- Alternative energy
- Raw materials extraction

2.2 Use for Other than the Intended Purpose

- Not a safety component in accordance with 2006/42/EC (Machinery Directive)
- The product is not suitable for use in potentially explosive atmospheres.
- The product may only be used with accessories supplied or approved by wenglor, or combined with approved products. A list of approved accessories and combination products can be accessed at www.wenglor.com on the product detail page.

DANGER!



Risk of personal injury or property damage in case of use for other than the intended purpose!

- Use for other than the intended purpose may lead to hazardous situations.
- Observe instructions regarding use for intended purpose.
-

2.3 Personnel Qualifications

- Suitable technical training is a prerequisite.
- In-house electronics training is required.
- Trained personnel must have uninterrupted access to the operating instructions.



DANGER!

Risk of personal injury or property damage in case of incorrect initial start-up and maintenance!

Personal injury and damage to equipment may occur.

- Adequate training and qualification of personnel.

2.4 Modification of Products



DANGER!

Risk of personal injury or property damage if the product is modified!

Personal injury and damage to equipment may occur. Non-observance may result in loss of the CE marking and the guarantee may be rendered null and void.

- Modification of the product is impermissible.

2.5 General Safety Precautions



NOTE!

- These instructions are an integral part of the product and must be kept on hand for the entire duration of its service life.
- In the event of possible changes, the respectively current version of the operating instructions can be accessed at www.wenglor.com in the product's download area.
- Read the operating instructions carefully before using the product.
- Protect the sensor against contamination and mechanical influences.

2.6 Laser/LED Warnings

The respective laser class or LED group is listed in the product's technical data.



Laser Class 1 (EN 60825-1)

Applicable standards and safety regulations must be observed.
 $P_p < 4\text{ mW}$, $t_p = 9,2\ \mu\text{s}$, $\lambda = 650\ \text{nm}$

2.7 Approvals and protection class



RoHS



3. Technical Data

Optical Data							
Service life (ambient temp. = +25 °C)	100000 h						
Max. permissible ambient light	10000 Lux						
Electrical Data							
Supply voltage	15...30 V DC						
IO-Link supply voltage	18...30 V DC						
Switching output voltage drop	< 2 V						
Switching output switching current	100 mA						
Switching output residual current	< 50 µA						
Short-circuit protection	Yes						
Reverse polarity protected	Yes						
Overload-proof	Yes						
Lockable	Yes						
Interface	IO-Link						
IO-Link version	1.1						
Protection class	III						
Mechanical Data							
Setting method	Teach-in						
Housing material	Plastic						
Degree of protection	IP67/IP68						
Lens cover	PMMA						
Technical Data	Order Number	P1NH					
		702	704	305	308	502	504
Range		300 mm		500 mm		800 mm	
Adjustable Range		65...300 mm		60...500 mm		80...800 mm	
Switching Hysteresis		< 2 %		< 3 %			
Light Source		Laser		Red Light			
Laser Class (EN 60825-1)		1		—		—	
Spot Diameter		see Table 3		see Table 1		see Table 5	
Current consumption		< 15 mA		< 20 mA			
Temperature drift		< 3 %		< 5 %			
Switching Frequency		800 Hz (see Table 2)				500 Hz (see Table 4)	
Response Time		1,25 ms (see Table 2)				1,5 ms (see Table 4)	
Temperature range		-25...60 °C			-40...60 °C		
Output function	PNP NO	x		x		x	
	NPN NO		x		x		x
Connection		Stecker M12, 4-pin					
Connection Diagram No.		221					
Suitable Mounting Technology No.		2					

3.1 Spot Diameter

Range	60 mm	250 mm	500 mm
Spot diameter	11 mm	13 mm	15 mm

Table 1

Range	160 mm	400 mm	800 mm
Spot diameter	16 mm	20 mm	23 mm

Table 2

Range	65 mm	150 mm	300 mm
Spot diameter	3 mm	2,5 mm	1,5 mm

Table 3

3.2 Switching Frequency / Response Time

The switching frequency and the response time are depending on 2 settings: operating mode and switching outputs. The following values result according to the setting:

Operating Mode	Outputs	
	2 independent switching outputs	1 switching output
Switching Frequency (Standard Mode)	150 Hz*	800 Hz
Response Time (Standard Mode)	3,3 ms*	1,25 ms
Switching Frequency (Interference-free Mode)	100 Hz	500 Hz
Response Time (Interference-free Mode)	5 ms	1,9 ms

*preset configuration

Table 4

Operating Mode	Outputs	
	2 independent switching outputs	1 switching output
Switching Frequency (Standard Mode)	100 Hz*	500 Hz
Response Time (Standard Mode)	4,2 ms*	1,5 ms
Switching Frequency (Interference-free Mode)	60 Hz	350 Hz
Response Time (Interference-free Mode)	6 ms	2,2 ms

*preset configuration

Table 5

3.2.1 Switching Distance Deviation

Typical characteristic curve based on Kodak white (90 % remission).

P1NH305, P1NH308

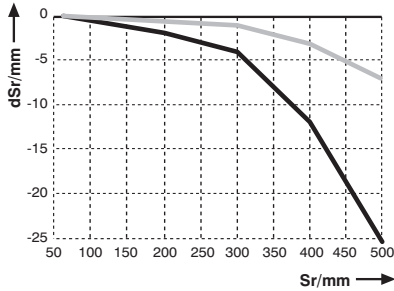

P1NH502, P1NH504

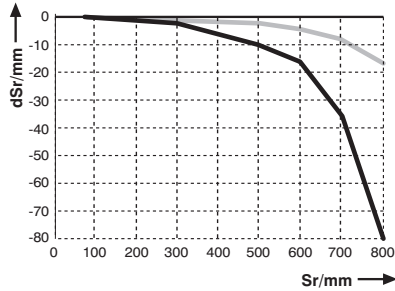

P1NH702, P1NH704

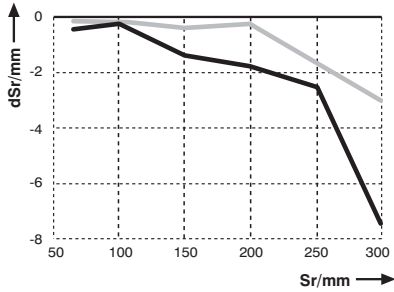

Sr = Switching Distance
dSr = Switching Distance Change
Black 6 % remission
Grey 18 % remission

3.3 Complementary Products

wenglor can provide you with suitable connection technology for your product.

Suitable mounting technology no. **350**

Suitable connection technology **2**

no.

S02

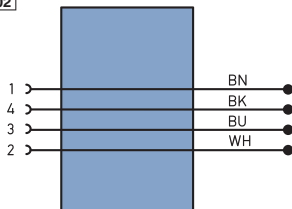

IO-Link master

wTeach2 software DNNF005

Protection Housing Set Z1NS001

STAUBTUBUS-03

3.4 Layout

P1NH305, P1NH308

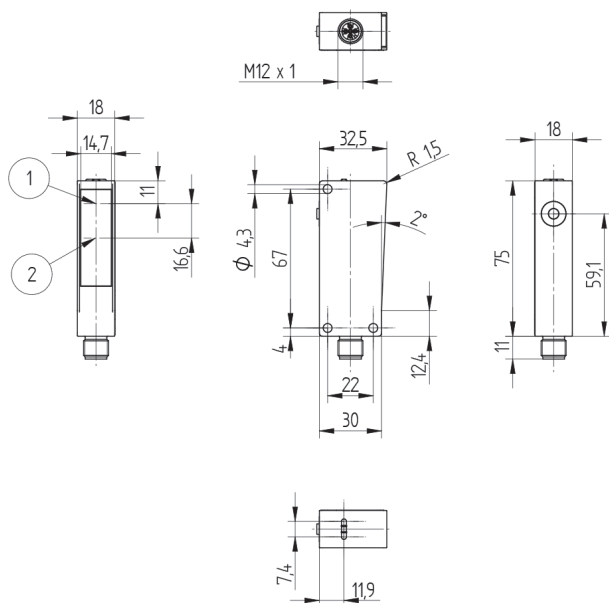

P1NH502, P1NH504

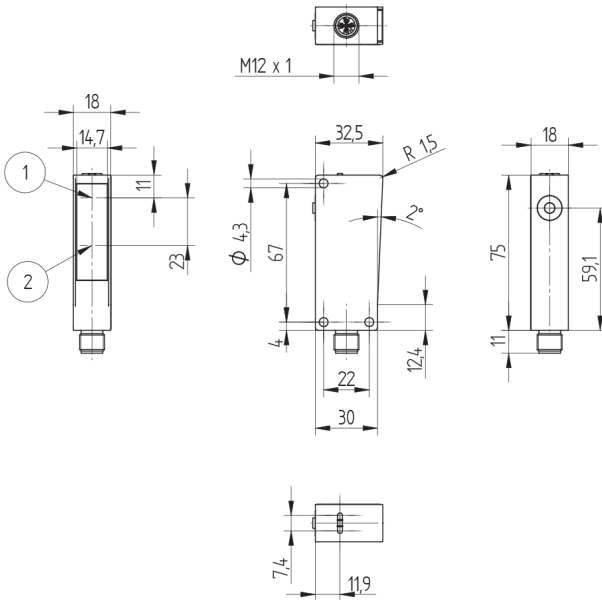

P1NH702, P1NH704

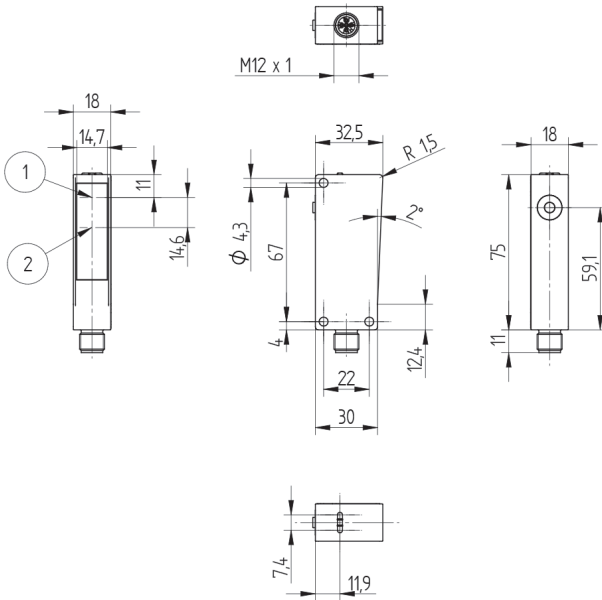

- ① = Emitter diode
- ② = Receiving diode

Screw M4 = 0,5 Nm

Dimensions specified in mm (1 mm = 0,03937 Inch)

3.5 Control Panel

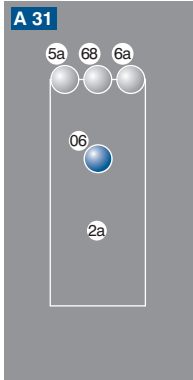

- 2a = NFC interface
- 5a = switching distance adjuster A1
- 6a = switching distance adjuster A2
- 06 = Teach Button
- 68 = supply power indicator

3.6 Scope of Delivery

- Sensor
- Safety precautions
- Mounting-Set 02

4. Transport and Storage

4.1 Transport

Upon receipt of shipment, the goods must be inspected for damage in transit. In the case of damage, conditionally accept the package and notify the manufacturer of the damage. Then return the device, making reference to damage in transit.

4.2 Storage

The following points must be taken into condition with regard to storage:

- Do not store the product outdoors.
- Store the product in a dry, dust-free place.
- Protect the product against mechanical impacts.
- Protect the product against exposure to direct sunlight.



ATTENTION!

Risk of property damage in case of improper storage!

The product may be damaged.

- Storage instructions must be complied with.
-

5. Installation and Electrical Connection

5.1 Installation

- Protect the product from contamination during installation.
- Observe all applicable electrical and mechanical regulations, standards, and safety rules.
- Protect the product against mechanical influences.
- Make sure that the sensor is mounted in a mechanically secure fashion.
- Specified torque values must be complied with ([see section "3. Technical Data", page 7](#)).



ATTENTION!

Risk of property damage in case of improper installation!

The product may be damaged.

- Installation instructions must be complied with.
-



CAUTION!

Risk of personal injury or property damage during installation!

Personal injury and damage to the product may occur.

- A safe installation environment must be assured.
-

5.2 Electrical Connection

221

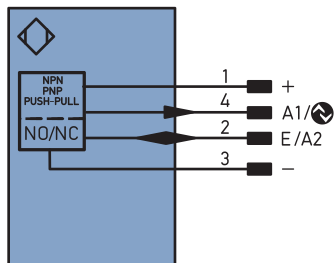

Legend

+	Supply Voltage +
-	Supply Voltage 0 V
~	Supply Voltage (AC Voltage)
A	Switching Output (NO)
Ā	Switching Output (NC)
V	Contamination/Error Output (NO)
∇	Contamination/Error Output (NC)
E	Input (analog or digital)
T	Teach Input
Z	Time Delay (activation)
S	Shielding
RxD	Interface Receive Path
TxD	Interface Send Path
RDY	Ready
GND	Ground
CL	Clock
E/A	Output/Input programmable
	IO-Link
PoE	Power over Ethernet
IN	Safety Input
QSSD	Safety Output
Signal	Signal Output
BL_D +/-	Ethernet Gigabit bidirect. data line (A-D)
ENRs422	Encoder 0-pulse 0-0̇ (TTL)

PT	Platinum measuring resistor
nc	not connected
U	Test Input
Ū	Test Input inverted
W	Trigger Input
W-	Ground for the Trigger Input
O	Analog Output
O-	Ground for the Analog Output
BZ	Block Discharge
AWV	Valve Output
a	Valve Control Output +
b	Valve Control Output 0 V
SY	Synchronization
SY-	Ground for the Synchronization
E+	Receiver-Line
S+	Emitter-Line
±	Grounding
SnR	Switching Distance Reduction
Rx +/-	Ethernet Receive Path
Tx +/-	Ethernet Send Path
Bus	Interfaces-Bus A(+)/B(-)
La	Emitted Light disengageable
Mag	Magnet activation
RES	Input confirmation
EDM	Contactor Monitoring

ENRs422	Encoder A/Ā (TTL)
ENBs422	Encoder B/B̄ (TTL)
ENa	Encoder A
ENb	Encoder B
AMIN	Digital output MIN
AMAX	Digital output MAX
AOK	Digital output OK
SY In	Synchronization In
SY OUT	Synchronization OUT
OLT	Brightness output
M	Maintenance
rsv	reserved
Wire Colors according to IEC 60757	
BK	Black
BN	Brown
RD	Red
OG	Orange
YE	Yellow
GN	Green
BU	Blue
VT	Violet
GY	Grey
WH	White
PK	Pink
GNYE	Green/Yellow

⚠ DANGER!



Risk of personal injury or property damage due to electric current!

Voltage conducting parts may cause personal injury or damage to equipment.









- The electric device may only be connected by appropriately qualified personnel.

5.3 Diagnostics

Causes for Triggering the Contamination Warning (blinking LED):

Display LED	Diagnosis/Cause	Elimination
Continuous blinking at approx. 2.5 Hz	Contamination	Carefully clean the optic cover with a cloth.
	Aged emitter diode	Replace the sensor.
	Unreliable working range	<ul style="list-style-type: none"> • Increase the sensor's switching distance. • Reduce distance between sensor and object.
Continuous blinking at approx. 5 Hz	Short-circuit	Check electrical wiring and eliminate the short-circuit.
	Over-temperature	Disconnect the sensor from supply power and allow it to cool down.
	Hardware error	Replace the sensor.

Contamination Warning Flowcharts

Reflex Mode		no contamination		
				
Object		not detected	detected	not detected
Switching Status Indicator		off ○	on ●	off ○
		beginning contamination		
				
Object		not detected	detected	not detected
Switching Status Indicator		off ○	blinking ●	off ○
		advanced contamination		
				
Object		not detected	not detected	not detected
Switching Status Indicator		off ○	off ○	off ○

6. Settings

The switching distance to the object can be taught in for both outputs by pressing the teach-in key on the sensor (default setting is foreground teach-in).

Teach-In for Switching Output 1

1. Mount the sensor in accordance with the mounting instructions.
2. Press and hold the teach-in key until switching status indicator LED A1 starts blinking.
3. Release the teach-in key after 2 seconds.
4. The distance is taught in and the LED at output 1 lights up in order to confirm successful teach-in.

Teach-In for Switching Output 2

1. Mount the sensor in accordance with the mounting instructions.
2. Press and hold the teach-in key until switching status indicator LED A2 starts blinking.
3. Release the teach-in key after 5 seconds.
4. The distance is taught in and the LED for output 2 lights up in order to confirm successful teach-in.



NOTE!

If teach-in is conducted without an object or if the object is too far from the sensor, switching distance is set to the end of the setting range.

7. Functions Overview

Further settings can be entered to the sensor via the IO-Link interface or NFC.

7.1 Teach Mode

7.1.1 Foreground Teach-In

Teaching in progress while the sensor is focused on the object. The switching distance is then automatically set to a distance which is slightly greater than the clearance between the sensor and the object. The sensor is thus activated for all objects whose distance to the sensor is equal to or less than the distance to the object used for the Teach-In procedure.

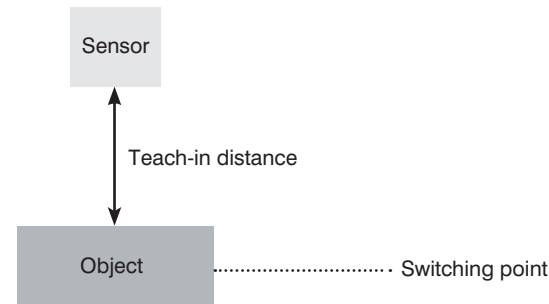

7.1.2 Background Teach-In

Teach-In is performed while the sensor spot is aligned to the background. The switching distance is then automatically set to a distance which is slightly less than the clearance between the sensor and the background. The sensor is thus activated whenever an object is located between the background and the sensor.

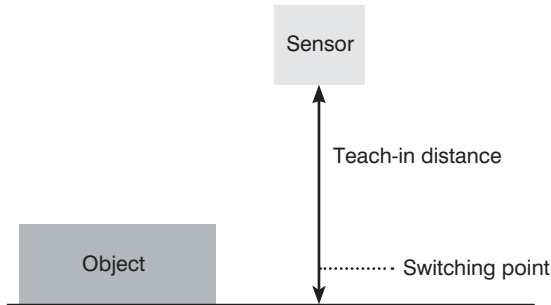

7.2 Pin Function, I/O2

The function of I/O2 can be configured either as an output or an input.

7.2.1 Input External Teach-In

Teach in output A1 via the teach-in input.

1. Set the E/A2 pin function to external teach-in.

With Ub setting active (default):

2. Apply 18...30 V to pin E/A2 for at least 1 second, but for no more than 4 seconds.
3. As soon as voltage drops at the input, A1 is taught in.

With Ub setting inactive:

2. Disconnect pin I/O2 or connect it to 0 V for at least 1 second, but for no more than 4 seconds.
3. As soon as voltage is applied to the input, O1 is taught in.

Locking

If the teach-in input is continuously activated, the teach-in key is locked and protected against inadvertent changes.

1. Change the E/A2 pin function to external teach-in input.

With Ub setting active (default):

2. Permanently connect pin E/A2 to voltage within a range of 18 to 30 V DC.
3. The sensor is protected against inadvertent changes caused by the teach-in key.

With Ub setting inactive:

2. Permanently disconnect pin I/O2 or connect it to 0 V.
3. The sensor is protected against inadvertent changes caused by the teach-in key.

7.2.2 Error Output

The error output is switched in the following cases:

- Contamination
- Aged emitter diode
- Unreliable working range
- Short-circuit
- Over-temperature
- Hardware error

7.3 Additional functions and settings

- PNP/NPN/push-pull
- NC/NO
- Switching hysteresis
- On/off-delay
- Operating mode
- Switch emitted light off
- Test mode
- Data storage (IO-Link)

8. IO-Link

Process and parameters data, as well as the IODD, can be found at www.wenglor.com in the product's separate download area.

9. NFC

The devices can be set up and their parameters can be configured via the NFC interface with the help of an Android smartphone and wenglor's "Sensor Configurator" app. Process data cannot be read out via NFC but they're available via IO-Link.

The wenglor app can be downloaded free of charge from the Google Play Store. Download the app and follow the installation instructions.

Scan the code below to access the wenglor app directly.



The settings are selected via the app and are then transmitted to the sensor.

With the "Read" or "Write" mode activated, hold the smartphone's antenna just above the sensor's active NFC sensing face.



NOTE!

- NFC antenna position varies from one smartphone to the next.
- Refer to the smartphone's operating instructions in order to determine the antenna's exact position.

If a connection isn't established immediately, move the smartphone across the sensing face until connection is successful.

The sensor doesn't necessarily have to be connected to supply voltage for data transmission, i.e. transmission is also possible in the de-energized state.

10. Maintenance Instructions



NOTE!

- This wenglor sensor is maintenance-free.
- Cleaning and inspection of the plug connections at regular intervals are advisable.
- Do not clean the sensor with solvents or cleansers which could damage the product.
- The product must be protected against contamination during initial start-up.

11. Proper Disposal

wenglor sensoric GmbH does not accept the return of unusable or irreparable products. Respectively valid national waste disposal regulations apply to product disposal.

12. Appendix

12.1 List of Abbreviations

Abbreviation	Meaning
Tu	Ambient temperature
Ub	Supply voltage
IODD	IO Device Description
MTTFd	Mean Time to Dangerous Failure

12.2 Change Index, Operating Instructions

Version	Date	Description/Change
1.0.0	30.07.19	Initial version of the operating instructions
1.1.0	24.10.19	Updates of “3 Technical Data” on page 7 ff
1.2.0	28.11.19	Updates of “3 Technical Data” on page 7 ff
1.3.0	07.07.20	Updates of “3 Technical Data” on page 7 ff

12.3 EU Declaration of Conformity

The EU declaration of conformity can be found on our website at www.wenglor.com in the product's download area.