

Laser Distance Sensor

Time of Flight

P1KY014 LASER

Part Number

PNG smart der wintec.

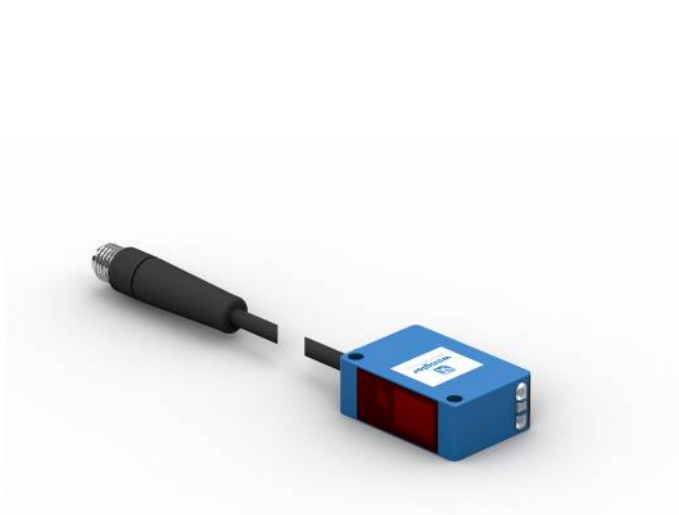

- 2 mutually independent switching outputs
- Interference-free towards gloss in the background with wintec
- Miniature design
- No mutual interference with wintec
- Reliable in case of glossy objects with wintec
- Secure detection of black objects also in extremely inclined positions with wintec

These miniature sensors determine distance between the sensor and the object by means of transit time measurement.

wenglor's interference-free technology (wintec) is revolutionizing sensor technology: it prevents numerous sensors arranged directly opposite or next to each other from interfering with one another. The sensors reach a very high switching frequency and use laser class 1, which is safe for the human eye.

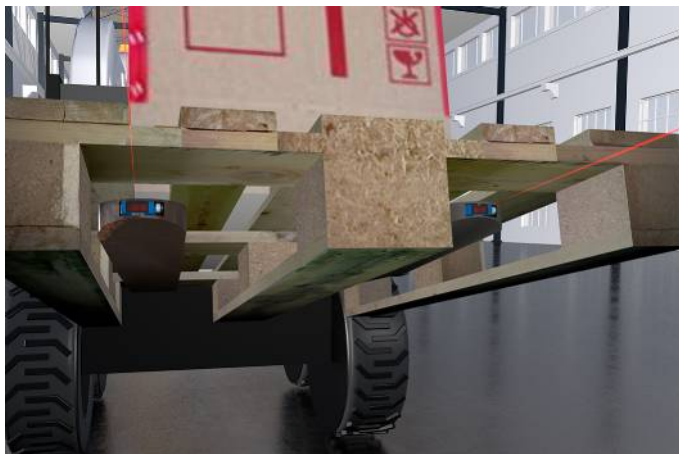

Technical Data

Optical Data	
Working Range	0...1000 mm
Setting Range	100...1000 mm
Switching Hysteresis	< 20 mm
Light Source	Laser (red)
Wavelength	680 nm
Service Life (T = +25 °C)	100000 h
Laser Class (EN 60825-1)	1
Beam Divergence	< 16 mrad
Max. Ambient Light	10000 Lux
Light Spot Diameter	see Table 1
Triple Dot Laser	yes
Electrical Data	
Supply Voltage	10...30 V DC
Supply Voltage with IO-Link	18...30 V DC
Current Consumption (U _b = 24 V)	< 30 mA
Switching Frequency	500 Hz
Response Time	1 ms
Temperature Drift (-10 °C < T _u ≤ 50 °C)	< 2 %
Temperature Drift (-40 °C < T _u ≤ 50 °C)	< 3 %
Temperature Range	-40...50 °C
Number of Switching Outputs	2
Switching Output Voltage Drop	< 2,5 V
Switching Output/Switching Current	100 mA
Short Circuit Protection	yes
Reverse Polarity Protection	yes
Overload Protection	yes
Interface	IO-Link V1.1
Protection Class	III
FDA Accession Number	1620293-001
Mechanical Data	
Setting Method	Teach-In
Housing Material	Plastic
Optic Cover	PMMA
Degree of Protection	IP67
Connection	M8 × 1; 4-pin
Cable Length	200 mm
Safety-relevant Data	
MTTFd (EN ISO 13849-1)	1021,76 a
NPN NC, NPN NO	●
IO-Link	●
Connection Diagram No.	223
Control Panel No.	A23
Suitable Connection Equipment No.	7
Suitable Mounting Technology No.	400

Complementary Products

IO-Link Master
Software

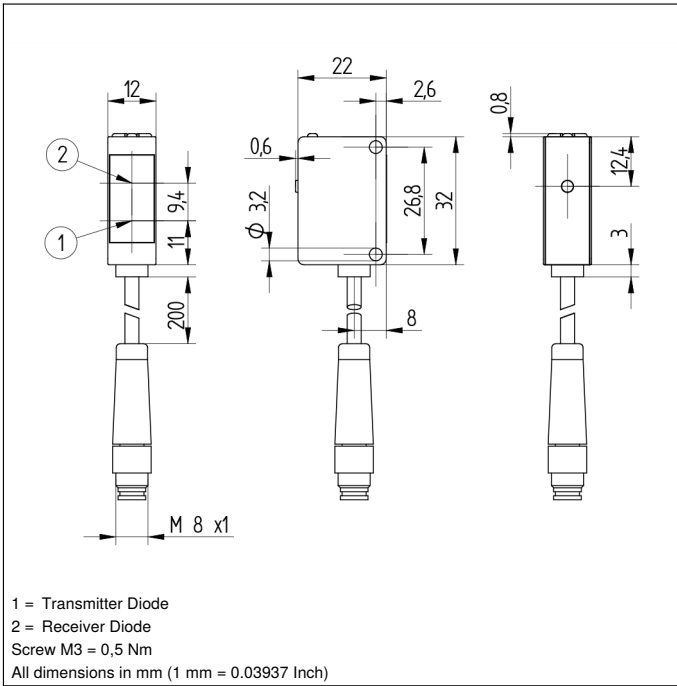

Ctrl. Panel

A 23

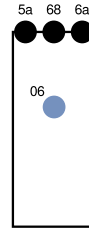

- 06 = Teach Button
- 5a = Switching Status Display, O1
- 68 = supply voltage indicator
- 6a = Switching Status Display, O2

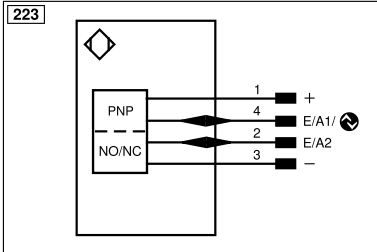

Legend			
+	Supply Voltage +	nc	Not connected
-	Supply Voltage 0 V	U	Test Input
~	Supply Voltage (AC Voltage)	Ü	Test Input inverted
A	Switching Output (NO)	W	Trigger Input
Ā	Switching Output (NC)	W-	Ground for the Trigger Input
V	Contamination/Error Output (NO)	O	Analog Output
ȳ	Contamination/Error Output (NC)	O-	Ground for the Analog Output
E	Input (analog or digital)	BZ	Block Discharge
T	Teach Input	Amv	Valve Output
Z	Time Delay (activation)	a	Valve Control Output +
S	Shielding	b	Valve Control Output 0 V
RxD	Interface Receive Path	SY	Synchronization
TxD	Interface Send Path	SY-	Ground for the Synchronization
RDY	Ready	E+	Receiver-Line
GND	Ground	S+	Emitter-Line
CL	Clock	±	Grounding
E/A	Output/Input programmable	SnR	Switching Distance Reduction
IO-Link	IO-Link	Rx+/-	Ethernet Receive Path
PoE	Power over Ethernet	Tx+/-	Ethernet Send Path
IN	Safety Input	Bus	Interfaces-Bus A(+)/B(-)
OSSD	Safety Output	La	Emitted Light disengageable
Signal	Signal Output	Mag	Magnet activation
BI_D+/-	Ethernet Gigabit bidirect. data line (A-D)	RES	Input confirmation
ENo RS422	Encoder 0-pulse 0/0 (TTL)	EDM	Contactor Monitoring
PT	Platinum measuring resistor	ENARs422	Encoder A/A (TTL)
			Wire Colors according to DIN IEC 60757
			BK Black
			BN Brown
			RD Red
			OG Orange
			YE Yellow
			GN Green
			BU Blue
			VT Violet
			GY Grey
			WH White
			PK Pink
			GNYE Green/Yellow

Table 1

Working Distance	100 mm	500 mm	1000 mm
Light Spot Diameter	4 mm	7 mm	15 mm

Switching Distance Deviation

Typical characteristic curve based on white, 90 % remission

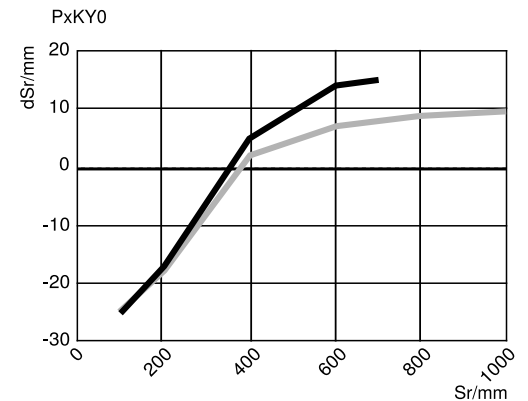

Sr = Switching Distance

dSr = Switching Distance Change

— black 6 % remission

— grey 18 % remission

