

# Reflex Sensor

## Energetic

# OTWK502A0002

Part Number



- Adjustable detection range
- Clever inclusive mounting technology
- IO-Link 1.1
- Large detection range
- Minimal installation space
- Simple installation

The transmitter and receiver in these sensors are located in a single housing. The sensor evaluates transmitted light reflected back from the object. The output is switched as soon as an object passes the selected range. Bright objects reflect more light than dark objects, and can thus be recognized from greater distances.

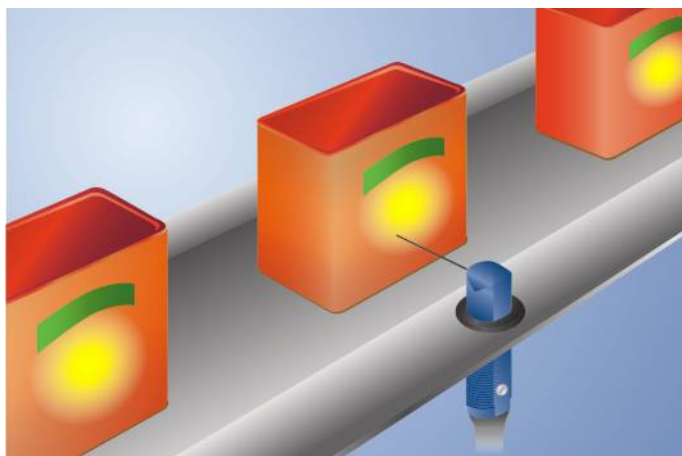

## Technical Data

Optical Data	
Range	500 mm
Switching Hysteresis	< 15 %
Light Source	Infrared Light
Service Life (T = +25 °C)	100000 h
Max. Ambient Light	10000 Lux
Opening Angle	5 °
Light Spot Diameter	see Table 1

Electrical Data	
Supply Voltage	10...30 V DC
Supply Voltage with IO-Link	18...30 V DC
Current Consumption (U <sub>b</sub> = 24 V)	< 30 mA
Switching Frequency	500 Hz
Response Time	1 ms
Temperature Drift	< 10 %
Temperature Range	-25...60 °C
Switching Output Voltage Drop	< 2,5 V
PNP Switching Output/Switching Current	200 mA
Residual Current Switching Output	< 50 µA
Short Circuit Protection	yes
Reverse Polarity Protection	yes
Overload Protection	yes
Lockable	yes
Interface	IO-Link V1.1
Protection Class	III

Mechanical Data	
Setting Method	Potentiometer
Housing Material	Plastic, ABS/GF
Degree of Protection	IP67
Connection	M12 × 1; 4-pin

Safety-relevant Data	
MTTFd (EN ISO 13849-1)	2988,01 a
Scope of delivery	1 × initial start-up instructions 1 × MUTTER-M18-E012 hex nut 1 × sensor 1 × Z0008 mounting console
Packaging unit	1 Piece

IO-Link	●
PNP NC, PNP NO	●
Connection Diagram No.	<b>215</b>
Control Panel No.	<b>DK1</b>
Suitable Connection Equipment No.	<b>2</b>
Suitable Mounting Technology No.	<b>150</b>

\*IO-Link availability is valid for all sensors from revision F. The revision can be found in the production order number "xxxxx/F/xxxxx," which is indicated on the product label.

## Complementary Products

IO-Link Master Software	
-------------------------	--

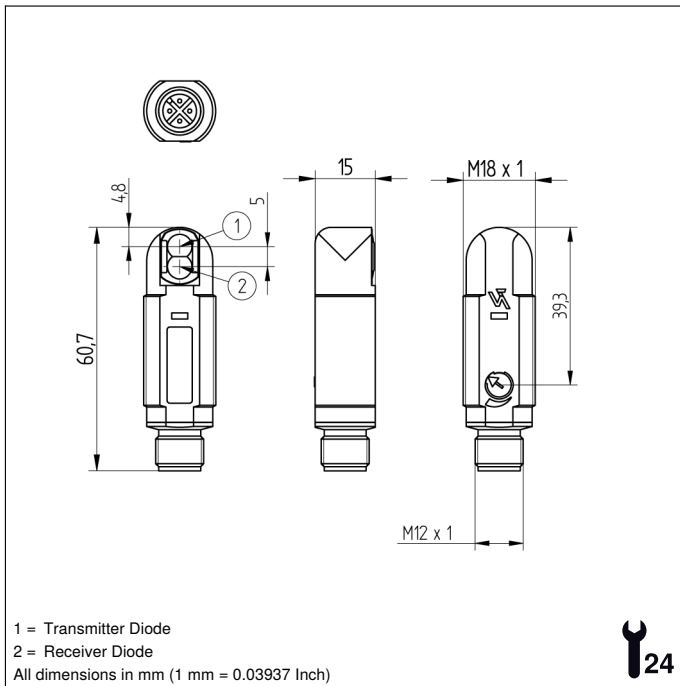

### Ctrl. Panel

DK1

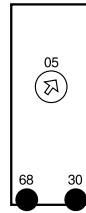

05 = Switching Distance Adjuster  
 30 = Switching Status/Contamination Warning  
 68 = Power LED

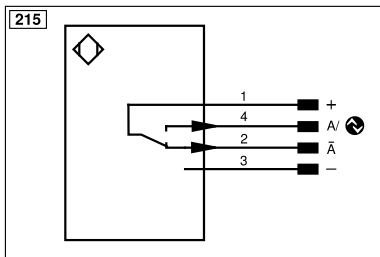

Legend			
+	Supply Voltage +	PT	Platinum measuring resistor
-	Supply Voltage 0 V	nc	Not connected
~	Supply Voltage (AC Voltage)	U	Test Input
A	Switching Output (NO)	Ū	Test Input inverted
Ā	Switching Output (NC)	W	Trigger Input
V	Contamination/Error Output (NO)	W-	Ground for the Trigger Input
Ṽ	Contamination/Error Output (NC)	O	Analog Output
E	Input (analog or digital)	O-	Ground for the Analog Output
T	Teach Input	BZ	Block Discharge
R	Reset input	Amv	Valve Output
Z	Time Delay (activation)	a	Valve Control Output +
S	Shielding	b	Valve Control Output 0 V
RxD	Interface Receive Path	SY	Synchronization
TxD	Interface Send Path	SY-	Ground for the Synchronization
RDY	Ready	E+	Receiver-Line
GND	Ground	S+	Emitter-Line
CL	Clock	⊕	Grounding
E/A	Output/Input programmable	SnR	Switching Distance Reduction
	IO-Link	Rx+/-	Ethernet Receive Path
PoE	Power over Ethernet	Tx+/-	Ethernet Send Path
IN	Safety Input	Bus	Interfaces-Bus A(+)/B(-)
QSSD	Safety Output	La	Emitted Light disengageable
Signal	Signal Output	Mag	Magnet activation
Bl_D+/-	Ethernet Gigabit bidirect. data line (A-D)	RES	Input confirmation
ENo RS422	Encoder 0-pulse 0/0 (TTL)	EDM	Contacting Monitoring
		ENARs422	Encoder A/Ā (TTL)
		ENBRs422	Encoder B/B̄ (TTL)
		ENA	Encoder A
		ENB	Encoder B
		AMIN	Digital output MIN
		AMAX	Digital output MAX
		AOK	Digital output OK
		SY In	Synchronization In
		SY OUT	Synchronization OUT
		OLt	Brightness output
		M	Maintenance
		rsv	Reserved
		Wire Colors according to DIN IEC 60757	
		BK	Black
		BN	Brown
		RD	Red
		OG	Orange
		YE	Yellow
		GN	Green
		BU	Blue
		VT	Violet
		GY	Grey
		WH	White
		PK	Pink
		GNYE	Green/Yellow

Table 1

Detection Range	100 mm	300 mm	500 mm
Light Spot Diameter	11 mm	26 mm	41 mm

