

Through-Beam Sensor

OEWK803A0091

Part Number



- Clever inclusive mounting technology
- Large working range
- Minimal installation space
- Simple installation
- Switching distance adjuster

Technical Data

Optical Data	
Range	8000 mm
Switching Hysteresis	< 15 %
Light Source	Red Light
Service Life (T = +25 °C)	100000 h
Max. Ambient Light	10000 Lux
Opening Angle	4 °
Electrical Data	
Sensor Type	Receiver
Supply Voltage	10...30 V DC
Current Consumption (U _b = 24 V)	< 20 mA
Switching Frequency	600 Hz
Response Time	833 μs
Temperature Drift	< 10 %
Temperature Range	-25...60 °C
Switching Output Voltage Drop	< 2,5 V
PNP Switching Output/Switching Current	100 mA
Residual Current Switching Output	< 50 μA
Short Circuit and Overload Protection	yes
Reverse Polarity Protection	yes
Protection Class	III
Mechanical Data	
Setting Method	Potentiometer
Housing Material	Plastic
Degree of Protection	IP67
Connection	Cable, 4-wire, 2 m
Scope of delivery	Mounting Console
PNP NO/NC antivalent	●
Connection Diagram No.	201
Control Panel No.	DK3
Suitable Mounting Technology No.	150
Suitable Emitter	
OSWK803Z0091	

These through-beam sensors are best suited for use in industrial environments. Thanks to their large working range, the devices demonstrate excellent functional reliability in highly contaminated environments. The sensors can be checked for correct functioning via the test input.

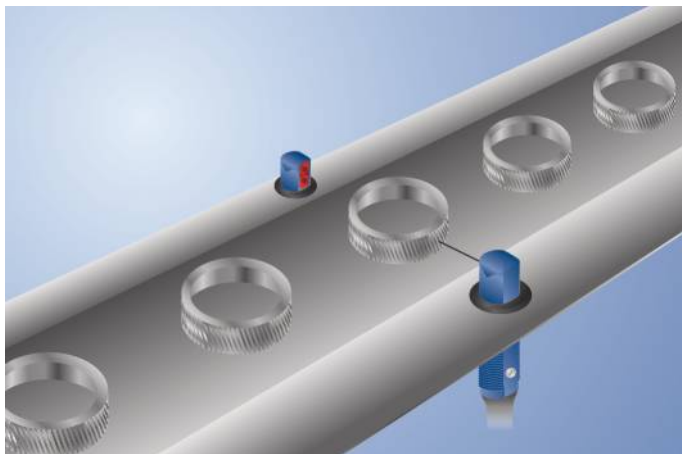

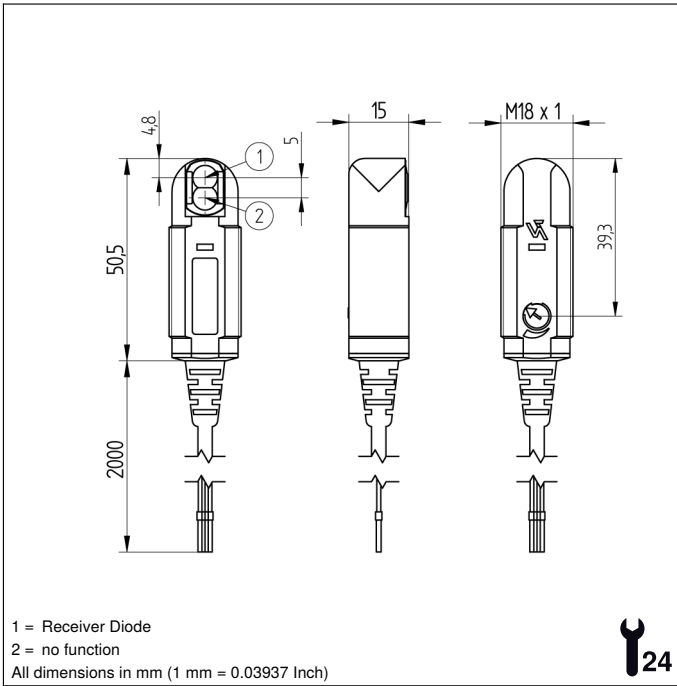

Ctrl. Panel

DK3



01 = Switching Status Indicator
 05 = Switching Distance Adjuster
 68 = supply voltage indicator

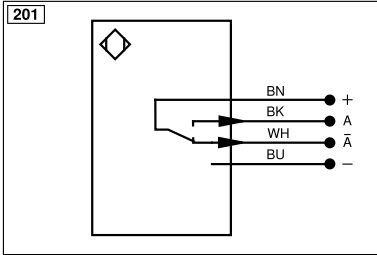

Legend			
+	Supply Voltage +	nc	Not connected
-	Supply Voltage 0 V	U	Test Input
~	Supply Voltage (AC Voltage)	Ū	Test Input inverted
A	Switching Output (NO)	W	Trigger Input
Ā	Switching Output (NC)	W-	Ground for the Trigger Input
V	Contamination/Error Output (NO)	O	Analog Output
ȳ	Contamination/Error Output (NC)	O-	Ground for the Analog Output
E	Input (analog or digital)	BZ	Block Discharge
T	Teach Input	Amv	Valve Output
Z	Time Delay (activation)	a	Valve Control Output +
S	Shielding	b	Valve Control Output 0 V
RxD	Interface Receive Path	SY	Synchronization
TxD	Interface Send Path	SY-	Ground for the Synchronization
RDY	Ready	E+	Receiver-Line
GND	Ground	S+	Emitter-Line
CL	Clock	±	Grounding
E/A	Output/Input programmable	SnR	Switching Distance Reduction
IO-Link		Rx+/-	Ethernet Receive Path
PoE	Power over Ethernet	Tx+/-	Ethernet Send Path
IN	Safety Input	Bus	Interfaces-Bus A(+)/B(-)
OSSD	Safety Output	La	Emitted Light disengageable
Signal	Signal Output	Mag	Magnet activation
BI_D+/-	Ethernet Gigabit bidirect. data line (A-D)	RES	Input confirmation
ENo RS422	Encoder 0-pulse 0/0 (TTL)	EDM	Contactor Monitoring
PT	Platinum measuring resistor	ENARs422	Encoder A/Ā (TTL)
		ENBRs422	Encoder B/Ī (TTL)
		ENA	Encoder A
		ENb	Encoder B
		AMIN	Digital output MIN
		AMAX	Digital output MAX
		Aok	Digital output OK
		SY In	Synchronization In
		SY OUT	Synchronization OUT
		OLT	Brightness output
		M	Maintenance
		rsv	Reserved
		Wire Colors according to DIN IEC 60757	
		BK	Black
		BN	Brown
		RD	Red
		OG	Orange
		YE	Yellow
		GN	Green
		BU	Blue
		VT	Violet
		GY	Grey
		WH	White
		PK	Pink
		GNYE	Green/Yellow