

# FXTT0xx

Temperature Sensor with IO-Link



## Operating Instructions

# Table of Contents

<b>1. General</b>	<b>4</b>
1.1 Information Concerning these Instructions	4
1.2 Explanations of Symbols	4
1.3 Limitation of Liability	5
1.4 Copyrights	5
<b>2. For Your Safety</b>	<b>6</b>
2.1 Use for Intended Purpose	6
2.2 Use for Other than the Intended Purpose	7
2.3 Personnel Qualifications	7
2.4 Modification of Products	7
2.5 General Safety Precautions	8
2.6 Approvals and IP Protection	8
<b>3. Technical Data</b>	<b>9</b>
3.1 Permissible Flow Rate	11
3.2 Housing Dimensions	12
3.3 Wiring Diagram	13
3.4 Accessory Products	13
3.5 Layout	14
3.6 Scope of Delivery	14
<b>4. Transport and Storage</b>	<b>14</b>
4.1 Transport	14
4.2 Storage	14
<b>5. Installation and Electrical Connection</b>	<b>15</b>
5.1 Installation	15
5.2 Installation Instructions for Devices with EHEDG Certification	16
5.3 Electrical Connection	17
5.4 Electrical Connection	17
5.5 Diagnostics	17

<b>6. Cleaning</b> .....	<b>18</b>
<b>7. Functions Overview</b> .....	<b>18</b>
7.1 Default Settings.....	18
7.2 Function Definitions .....	18
7.2.1 Hysteresis.....	19
7.2.2 Window Width .....	19
7.2.3 Analog .....	20
7.2.4 Remote Output.....	20
7.2.5 Filter .....	22
<b>8. Settings</b> .....	<b>23</b>
<b>9. IO-Link</b> .....	<b>24</b>
<b>10. Maintenance Instructions</b> .....	<b>24</b>
<b>11. Returns</b> .....	<b>24</b>
<b>12. Proper Disposal</b> .....	<b>24</b>
<b>13. Appendix</b> .....	<b>25</b>
13.1 Change Index, Operating Instructions .....	25
13.2 EU Declaration of Conformity .....	25

# 1. General

## 1.1 Information Concerning these Instructions

- These instructions apply to the product with ID code FXFF0xx.
- They make it possible to use the product safely and efficiently.
- These instructions are an integral part of the product and must be kept on hand for the entire duration of its service life.
- Local accident prevention regulations and national work safety regulations must be complied with as well.
- The product is subject to further technical development, and thus the information contained in these operating instructions may also be subject to change. The current version can be found at [www.wenglor.com](http://www.wenglor.com) in the product's separate download area.



### NOTE!

The operating instructions must be read carefully before using the product and must be kept on hand for later reference!

## 1.2 Explanations of Symbols

- Safety precautions and warnings are emphasized by means of symbols and attention-getting words.
- Safe use of the product is only possible if these safety precautions and warnings are adhered to.
- The safety precautions and warnings are laid out in accordance with the following principle:



### Attention-Getting Word Type and Source of Danger!

Possible consequences in the event that the hazard is disregarded.

- Measures for averting the hazard.

---

The meanings of the attention-getting words, as well as the scope of the associated hazards, are listed below.



### DANGER!

This word indicates a hazard with a high degree of risk which, if not avoided, results in death or severe injury.

---



### WARNING!

This word indicates a hazard with a medium degree of risk which, if not avoided, may result in death or severe injury.

---



### CAUTION!

This word indicates a hazard with a low degree of risk which, if not avoided, may result in minor or moderate injury.

---

**ATTENTION!**

This word draws attention to a potentially hazardous situation which, if not avoided, may result in property damage.

---

**NOTE!**

A note draws attention to useful tips and suggestions, as well as information regarding efficient, error-free use.

### 1.3 Limitation of Liability

- The product has been developed in consideration of the current state-of-the-art and applicable standards and guidelines. Subject to change without notice. A valid declaration of conformity can be accessed at [www.wenglor.com](http://www.wenglor.com) in the product's separate download area.
- wenglor sensoric elektronische Geräte GmbH (hereinafter referred to as "wenglor") excludes all liability in the event of:
  - Non-compliance with the instructions
  - Use of the product for purposes other than those intended
  - Use by untrained personnel
  - Use of unapproved replacement parts
  - Unapproved modification of products
- These operating instructions do not include any guarantees from wenglor with regard to the described procedures or specific product characteristics.
- wenglor assumes no liability for printing errors or other inaccuracies contained in these operating instructions, unless wenglor was verifiably aware of such errors at the point in time at which the operating instructions were prepared.

### 1.4 Copyrights

- The contents of these instructions are protected by copyright law.
- All rights are reserved by wenglor.
- Commercial reproduction or any other commercial use of the provided content and information, in particular graphics and images, is not permitted without previous written consent from wenglor.

## 2. For Your Safety

### 2.1 Use for Intended Purpose

The product is based on the following functional principle:

#### Temperature Sensor

The Temperature Sensor measures the temperature of liquid and gaseous media, and makes it possible to monitor temperature within processes.

There's a sensor in the measuring probe of the wenglor Temperature Sensor which detects temperature changes and converts them into electrical signals. The sensor's parameters can be configured via IO-Link and adapted to the respective application. Either two switching outputs, one switching output and one analog output (4 to 20 mA/ 0 to 10 V) or one 2-wire analog output (4 to 20 mA) is available depending on settings and connection configuration.

This product can be used in the following industry sectors:

- Special machinery manufacturing
- Heavy machinery manufacturing
- Logistics
- Automotive industry
- Food industry
- Packaging industry
- Pharmaceuticals industry
- Clothing industry
- Plastics industry
- Woodworking industry
- Consumer goods industry
- Paper industry
- Electronics industry
- Glass industry
- Steel industry
- Printing industry
- Construction industry
- Chemicals industry
- Agriculture industry
- Alternative energy
- Raw materials extraction

## 2.2 Use for Other than the Intended Purpose

- Not a safety component in accordance with 2006/42/EC (Machinery Directive)
- The product is not suitable for use in potentially explosive atmospheres.
- The product may only be used with accessories supplied or approved by wenglor, or in combination with approved products. A list of approved accessories and combination products can be accessed at [www.wenglor.com](http://www.wenglor.com) on the product detail page.



**DANGER!**

**Risk of personal injury or property damage in case of use for other than the intended purpose!**

Use for other than the intended purpose may lead to hazardous situations.

- Instructions regarding use for intended purpose must be observed.
- 

## 2.3 Personnel Qualifications

- Suitable technical training is a prerequisite.
- In-house electronics training is required.
- Trained personnel must have uninterrupted access to the operating instructions.



**DANGER!**

**Risk of personal injury or property damage in case of incorrect initial start-up and maintenance!**

Personal injury and damage to equipment may occur.

- Adequate training and qualification of personnel.
- 

## 2.4 Modification of Products



**DANGER!**

**Risk of personal injury or property damage if the product is modified!**

Personal injury and damage to equipment may occur. Non-observance may result in loss of the CE marking and the guarantee may be rendered null and void.

- Modification of the product is impermissible.
-

## 2.5 General Safety Precautions

### NOTE!

- These instructions are an integral part of the product and must be kept on hand for the entire duration of its service life.
- In the event of possible changes, the respectively current version of the operating instructions can be accessed at [www.wenglor.com](http://www.wenglor.com) in the product's separate download area.
- Read the operating instructions carefully before using the product.
- Protect the sensor against contamination and mechanical influences.
- Installation and removal of the product are only permissible in pressure-free piping systems which have been allowed to cool down.



## 2.6 Approvals and IP Protection

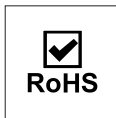
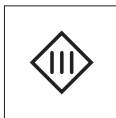

### 3. Technical Data

Technical Data	Order Number	FXTT0xx
<b>Sensor-Specific Data</b>		
Measuring range		-50...150° C
Setting range		-50...150° C
Medium		Liquids, gases
Measuring error		± 0.5° C
Step response time T90		< 2 s
Resolution		0.01° C
<b>Ambient Conditions</b>		
Ambient temperature		-25...80° C
Media temperature		-50...150° C
Storage and transport temperature		-40...100° C
Relative humidity		95 % rel.h.
Operating height		< 2000 m
EMC		DIN EN 61326-2-3
Shock resistance		50 g/11 ms
Vibration resistance		20 g (10...2000 Hz)
<b>Electrical Data</b>		
Supply power		
2-wire		12...32 V DC ± 10 %
3-wire		12...32 V DC ± 10 %
IO-Link		18...30 V DC ± 10 %
Current consumption (U <sub>o</sub> = 24 V)		≤ 25 mA
Overvoltage category		II
Maximum overvoltage		34 V DC
Short-circuit proof		Yes
Reverse polarity and overload-proof		Yes
<b>Analog output</b>		
Output load resistance		4...20 mA / 0...10 V $< \frac{(U_b - U_{min})}{20 \text{ mA}} > / > 1 \text{ kOhm}$
<b>Switching output</b>		
Voltage drop		< 1.5 V
Switching current		≤ 100 mA
Residual current		< 250 μA
Switchable to NC or NO		Yes
Interface		IO-Link
IO-Link version		1.1
Protection class		III
Operating delay time		< 300 ms
Pollution Degree		2

<b>Mechanical Data</b>	
Setting method	IO-Link
Housing material	Stainless steel 1.4404
Media contacting materials	Stainless steel 1.4404
Protection	IP68, IP69K
Connector type	M12 × 1, 4-pin
Process connection	See data sheet
Process connection length PCL	See data sheet
Probe Length PL	See data sheet
Rod diameter	6 mm
<b>Output Function</b>	
Switching output	2 each
Analog output	2-wire 3-wire
Configurable as PNP, NPN or push-pull	Yes
Switchable to NC or NO	Yes

The sensors are UL certified for indoor use only.

For use in North America and/or Canada:

The equipment must be supplied from an isolated power source that meets the requirements:

Energy limited circuit according to UL/CSA 61010-1/UL/CSA 61010-2-201 or Limited power source (LPS) according to UL/CSA 60950-1 or A Class 2 power source that meets the requirements of the National Electrical Code (NEC), NFPA 70, Clause 725.121 and Canadian Electrical Code (CEC), Part I, C22.1. (Typical examples are a Class 2 transformer or a Class 2 power source according to UL 5085-3/CSA-C22.2 No. 66.3 or UL 1310/CSA-C22.2 No. 223).

The following table specifies the tightening torques of the plugs and mounting options in order to assure compliant, error-free operation:

<b>Connector Type</b>	<b>Tightening Torque (Nm)</b>
<b>Supply voltage and signal connection</b>	
M12	0,4
<b>Process connection</b>	
G1/4" external thread	30
G1/2" external thread	30
M18 × 1.5 sealing cone	15

**CAUTION!**



- Pressure resistance specified in the data sheet always makes reference to the sensor rod.
- Amongst other factors, the system's pressure resistance is also dependent on the utilized mounting components (adapters), and is only as high as the pressure resistance of the weakest component.

### 3.1 Permissible Flow Rate

Maximum permissible flow rate depending on the temperature of the medium, pressure and probe length:

Pressure	Probe Length					Medium Temperature
	10 mm	50 mm	100 mm	150 mm	200 mm	
PN25 (25 bar)	400 cm/s	400 cm/s	400 cm/s	400 cm/s	400 cm/s	20° C
						60° C
						100° C
						150° C
PN40 (40 bar)	400 cm/s	400 cm/s	400 cm/s	400 cm/s	400 cm/s	20° C
						60° C
					350 cm/s	100° C
						150° C
PN64 (64 bar)	400 cm/s	400 cm/s	400 cm/s	400 cm/s	200 cm/s	20° C
					150 cm/s	60° C
						100° C
						150° C
PN100 (100 bar)	400 cm/s	400 cm/s	400 cm/s	400 cm/s	Not permissible	20° C
				350 cm/s		60° C
				300 cm/s		100° C
						150° C



### 3.3 Wiring Diagram

139

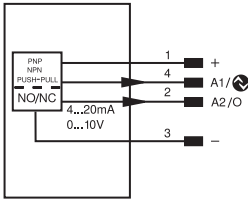

142

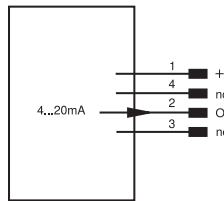

#### Legend

+	Supply Voltage +
-	Supply Voltage 0 V
~	Supply Voltage (AC Voltage)
A	Switching Output (NO)
Ā	Switching Output (NC)
V	Contamination/Error Output (NO)
Ṽ	Contamination/Error Output (NC)
E	Input (analog or digital)
T	Teach Input
Z	Time Delay (activation)
S	Shielding
RxD	Interface Receive Path
TxD	Interface Send Path
RDY	Ready
GND	Ground
CL	Clock
E/A	Output/Input programmable
	IO-Link
PoE	Power over Ethernet
IN	Safety Input
OSD	Safety Output
Signal	Signal Output
BL_D	Ethernet Gigabit bidirect. data line (A-D)
EN0ms42	Encoder 0-pulse 0-0̇ (TTL)

PT	Platinum measuring resistor
nc	not connected
U	Test Input
Ū	Test Input inverted
W	Trigger Input
W-	Ground for the Trigger Input
O	Analog Output
O-	Ground for the Analog Output
BZ	Block Discharge
AW	Valve Output
a	Valve Control Output +
b	Valve Control Output 0 V
SY	Synchronization
SY-	Ground for the Synchronization
E+	Receiver-Line
S+	Emitter-Line
±	Grounding
Sr	Switching Distance Reduction
Rx+/-	Ethernet Receive Path
Tx+/-	Ethernet Send Path
Ba	Interfaces-Bus A(+)/B(-)
La	Emitted Light disengageable
Mag	Magnet activation
RES	Input confirmation
EDM	Contacting Monitoring

ENAs42	Encoder A/Ā (TTL)
ENBs42	Encoder B/B̄ (TTL)
ENa	Encoder A
ENb	Encoder B
AMIN	Digital output MIN
AMAX	Digital output MAX
AOk	Digital output OK
SY in	Synchronization In
SY OUT	Synchronization OUT
OLY	Brightness output
M	Maintenance
rsv	reserved
Wire Colors according to IEC 60757	
BK	Black
BN	Brown
RD	Red
OG	Orange
YE	Yellow
GN	Green
BU	Blue
VT	Violet
GY	Grey
WH	White
PK	Pink
GNYE	Green/Yellow

### 3.4 Accessory Products

wenglor can provide you with suitable connection technology for your product.

Suitable mounting technology no.

Cutting/locking ring: **907 908**  
M18 × 1 sealing cone: **900 901**

Suitable connection technology no.

**2**

502

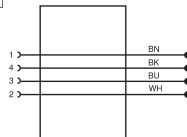

IO-Link master

ZAI72AN01  
EFBL001  
EFBL002

### 3.5 Layout

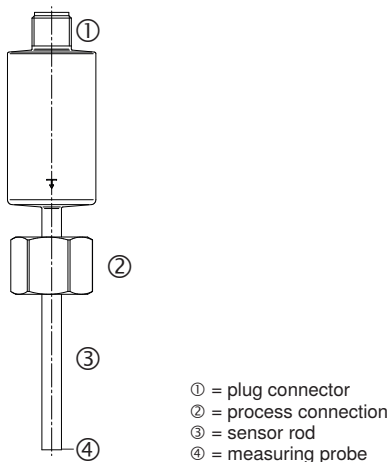

### 3.6 Scope of Delivery

- FXTTxxx Temperature Sensor

## 4. Transport and Storage

### 4.1 Transport

Upon receipt of shipment, inspect the goods for damage in transit. In the case of damage, conditionally accept the package and notify the manufacturer of the damage. Then return the device, making reference to damage in transit.

### 4.2 Storage

The following points must be taken into condition with regard to storage:

- Do not store the product outdoors.
- Store the product in a dry, dust-free place.
- Protect the product against mechanical impacts.



---

#### **ATTENTION!**

#### **Risk of property damage in case of improper storage!**

The product may be damaged.

- Comply with storage instructions.
-

## 5. Installation and Electrical Connection

### 5.1 Installation

- Protect the product from contamination during installation.
- Observe all applicable electrical and mechanical regulations, standards, and safety rules.
- Protect the product against mechanical influences.
- Make sure that the sensor is mounted in a mechanically secure fashion.
- Specified torque values must be complied with (see table [Page 10](#)).



#### **ATTENTION!**

##### **Risk of property damage in case of improper installation!**

- The product may be damaged.
- Comply with installation instructions.



#### **CAUTION!**

##### **Risk of personal injury or property damage during installation!**

- Personal injury and damage to the product may occur.
- Ensure a safe installation environment.
-

## 5.2 Installation Instructions for Devices with EHEDG Certification

Sensors with an "EHEDG Certified" label (see technical data for the respective sensor) are suitable for CIP applications and do not have to be removed for cleaning. The following instructions must be adhered to in order to comply with EHEDG certification:

- The product may only be mounted to suitable equipment which complies with EHEDG guidelines.
- The product must be installed such that there is no dead space.
- The equipment must be set up such that the system can subsequently still be entirely emptied.
- If mounted to a T-fitting, the necking may not be longer than the inside diameter of it minus the sensor probe diameter:  $L < (D - d)$ .

– Example:

Diameter necking  $D = 20$  mm

Diameter sensor probe  $d = 6$  mm

Length  $L < 20 - 6$  mm  $\rightarrow L < 14$  mm

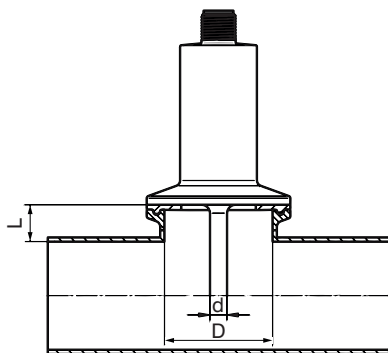

- If the product is mounted to a tank, the cleaning device must be installed so that it directly flushes the connection/dead space.
- Only suitable seals may be used which comply with EHEDG guidelines. In particular in the case of fittings in accordance with DIN 11851 (dairy pipe fittings) and DIN 32676 (clamp connections), the seal must be chosen according to the EHEDG Position Paper on easy cleanable pipe couplings and process connections. Suitable seals can be purchased from a specialist retailer.
- Varivent connection:
  - Restriction type F: Installation only permitted in tank mounting flanges
  - Type N: Installation in tank mounting flanges and pipelines

## 5.3 Electrical Connection

- Connect the sensor to 12 to 32 V DC (see “3.4 Wiring Diagram” on page 13).
- When operated with IO-Link:
  - An IO-Link master with class A port must be used because pin 5 is not connected in the case of a class A port.
  - In the case of excessive interference, a shielded cable should be used.



### **DANGER!**

#### **Risk of personal injury or property damage due to electric current!**

Voltage conducting parts may cause personal injury or damage to equipment.

- The electric device may only be connected by appropriately qualified personnel.
- 

## 5.4 Electrical Connection

- Connect the sensor to 12 to 32 V DC (see “3.3 Wiring Diagram” on page 13).
- When operated with IO-Link:
  - An IO-Link master with class A port must be used because pin 5 is not connected in the case of a class A port.
  - In the case of excessive interference, a shielded cable should be used.



### **DANGER!**

#### **Risk of personal injury or property damage due to electric current!**

Voltage conducting parts may cause personal injury or damage to equipment.

- The electric device may only be connected by appropriately qualified personnel.
- 

## 5.5 Diagnostics

Required action in case of fault:



### **NOTE!**

- Shut down the machine.
- If the error cannot be eliminated, please contact wenglor's support department.
- Do not operate in case of indeterminate malfunctioning.
- The machine must be shut down if the error cannot be unequivocally clarified or reliably eliminated.



### **DANGER!**

#### **Risk of personal injury or property damage in case of non-compliance!**

The system's safety function is disabled. Personal injury and damage to equipment.

- Required action as specified in case of fault.
-

## 6. Cleaning

- Sensors with an “EHEDG Certified” label are suitable for CIP applications and do not have to be removed for cleaning.
- Permissible ambient temperature and degree of protection must be observed when cleaning from the outside.
- When selecting a cleaning agent, the degree of resistance demonstrated by the materials must be taken into consideration. A resistance table can be downloaded from [wenglor.com](http://wenglor.com).

## 7. Functions Overview

### 7.1 Default Settings

		<b>FXTT0xx</b>
Function A1	Output	Switching output
	Measurement, physical quantity	Temperature
	Output function	PNP NO
	Switching point 1	75° C
	Switching point 2	50° C
Function A2	Output	Analog output
	Measurement, physical quantity	Temperature
	Output function	Current: 4 ... 20 mA
	Initial value, analog output	-50° C
	Final value, analog output	150° C

### 7.2 Function Definitions

- All functions are configured via the IO-Link interface.
- Refer to the interface protocol concerning parameters configuration (available at [www.wenglor.com](http://www.wenglor.com) on the product detail page).

<b>Designation</b>	<b>Function</b>	<b>Page</b>
Hysteresis	Adjust switching hysteresis	Page 19
Window width	Set window width	Page 19
Analog	Scale analog output	Page 20
Remote output	Output for external control signals	Page 20
Filter	Set the filter	Page 22

## 7.2.1 Hysteresis

- Depending on the settings selected for switching points 1 and 2, the sensor's switching performance can be adjusted to the application.

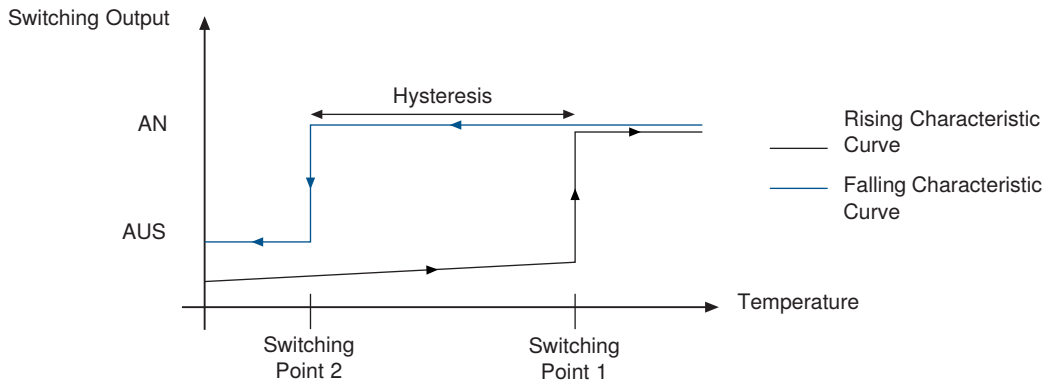

## 7.2.2 Window Width

- If switching points 1 and 2 are reversed, a window for actual and target value comparison can be set up with just one switching output.
- Refer to the interface protocol concerning parameters configuration (available at [www.wenglor.com](http://www.wenglor.com) on the product detail page).

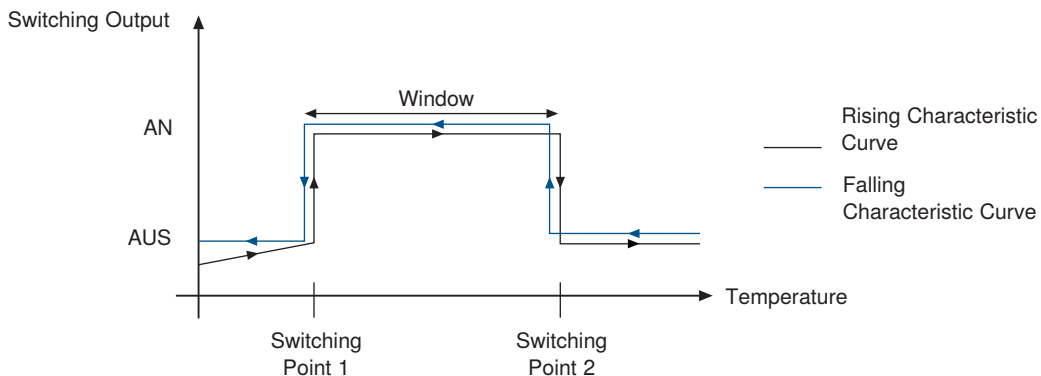

**Hysteresis amounts to 0.5° C for temperature.**

### 7.2.3 Analog

- Allocation of the analog starting point of 4 mA/0 V and the analog end point of 20 mA/10 V to the measuring range is freely selectable.

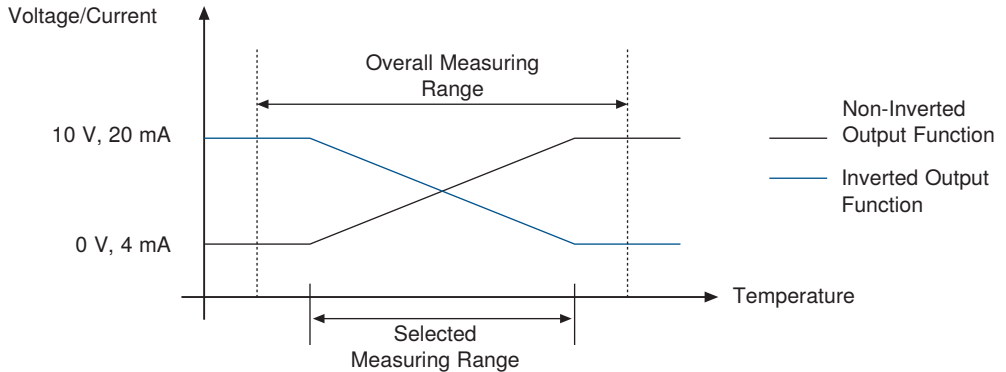

### 7.2.4 Remote Output

#### General Explanation

- If the sensor is operated with IO-Link (pin 4), the free output (pin 2) can be used for control signals.
- The output can be configured as a switching output or as an analog output.
- In this way, the need for an additional output at the controller is eliminated and external components can be switched by the sensor (e.g. a lamp) or actuated by means of an analog control signal (U/I) (e.g. a valve).

#### Prerequisite

- The sensor must be operated via IO-Link.

#### Procedure

- See figures 1 and 2 below with regard to wiring and connection.
- Setup via IO-Link in order to specify whether pin 2 is a remote analog output (U/I) or a remote switching output.
- The controller transmits the signal intended for the external component via IO-Link.
- The sensor transmits the signal to pin 2 (analog or switching output) and forwards it.
- The external component is controlled by the sensor's output. No additional output is required at the controller.
- The analog output can be scaled from 0 ... 1000 (0 = 4 mA / 0 V, 1000 = 20 mA / 10 V).

## Wiring

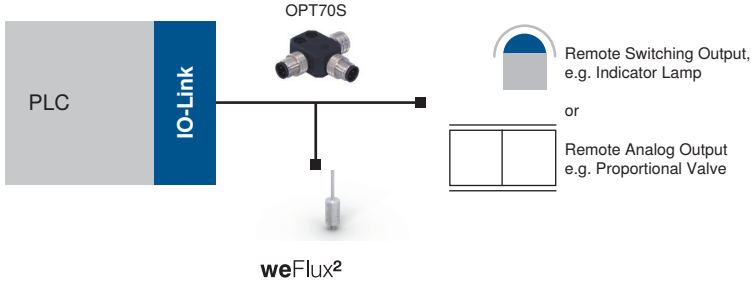

Figure 1: Wiring With Remote Output Function

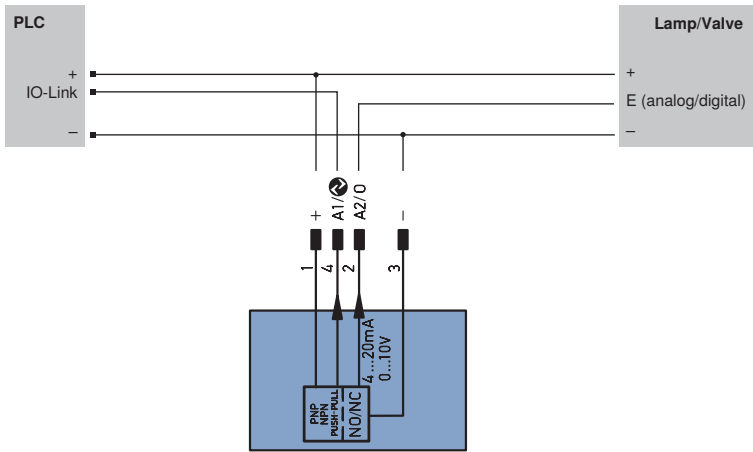

Figure 2: Wiring

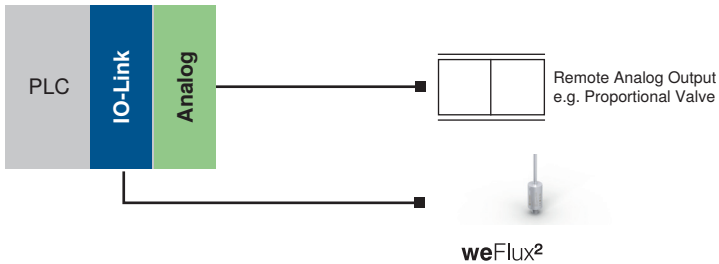

Figure 3: Wiring Without Remote Output Function

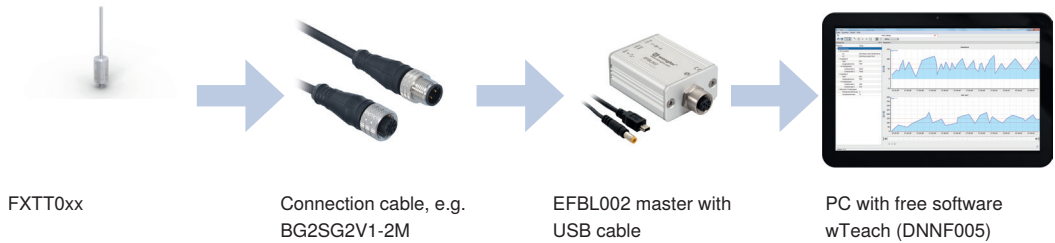

Figure 4: Cables when using wTeach

### 7.2.5 Filter

- The filter represents the number of values used by the sensor to generate a mean value.
- The higher the filter number, the longer the sensor's step response time  $T_{90}$  when the measured values change.

Filter	Number of Measured Values	Step Response Time $T_{90}$
0	1	Approx. 1.2 s
1	2	Approx. 1.3 s
2	4	Approx. 1.4 s
3	8	Approx. 1.5 s
4 (default)	16	Approx. 1.8 s
5	32	Approx. 2.4 s
6	64	Approx. 3.6 s
7	128	Approx. 5.9 s
8	256	Approx. 11 s
9	512	Approx. 20 s
10	1024	Approx. 39 s

## 8. Settings

Parameters adjustable via the IO-Link interface:

<b>Sensor Settings</b>	
Temperature unit of measure	°C °F
Switching output function	PNP NPN Push-pull
Function, output 2	Switching output Analog output Remote switching output Remote analog output
Filter	0 ... 10 where 0 = filter off
<b>Output Settings</b>	
<b>Output 1 (switching output)</b>	
Switching point 1	-50...150° C
Switching point 2	-50 ... 150° C
Switching function	NO NC
<b>Output 2 (switching output)</b>	
– only visible if switching output has been selected for “Function, output 2” –	
Switching point 1	-50...150° C
Switching point 2	-50...150° C
Switching function	NO NC
<b>Output 2 (analog output)</b>	
– only visible is analog output has been selected for “Function, output 2” –	
Starting temperature (value for 4 mA / 0 V)	-50...150° C
End temperature (value for 20 mA / 10 V)	-50...150° C
Analog output	Current: 4...20 mA Voltage 0...10 V
<b>Output 2 (remote switching output)</b>	
– only visible if remote switching output has been selected for “Function, output 2” –	
Output	Open/closed
<b>Output 2 (remote analog output)</b>	
– only visible if remote analog output has been selected for “Function, output 2” –	
Analog value	0 to 1000
<b>Sensor Restrictions</b>	
Write access disabling	Yes No
Data storage disabling	Yes No
<b>Sensor Commands</b>	
Standard	Restore default settings

#### Process data available via IO-Link interface:

- Status of the switching outputs
- Media temperature



#### NOTE!

When setting and evaluating the sensor via wTeach2, the wenglor USB master EFBL002 is required.

## 9. IO-Link

Process and parameters data can be found at [www.wenglor.com](http://www.wenglor.com) in the product's separate download area.

## 10. Maintenance Instructions

#### NOTE!



- This wenglor sensor is maintenance-free.
- Cleaning and inspection of the plug connections at regular intervals is advisable.
- Do not clean the sensor with solvents or cleansers which could damage the product.
- The product must be protected against contamination during initial start-up.
- Contamination which adheres to the measuring probe distorts the measured value for flow rate.

## 11. Returns

Due to legal regulations and for the protection of employees, wenglor sensoric GmbH requires a signed declaration of decontamination before your order can be processed.

The corresponding form is available at [www.wenglor.com](http://www.wenglor.com) → Download → General Terms and Conditions and Returns.

## 12. Proper Disposal

wenglor sensoric GmbH does not accept the return of unusable or irreparable products. Respectively valid national waste disposal regulations apply to product disposal.

## 13. Appendix

### 13.1 Change Index, Operating Instructions

Version	Date	Description/Change
1.0.0	08.06.2016	Initial version of the operating instructions
1.1.0	27.10.2016	Expansion of the connection cables and adaptation of supplementary products in the system overview
1.2.0	28.11.2016	Adaptation of sensor specific data
1.3.0	16.01.2017	Adaptation of supply voltage in the 2-wire operating mode
1.4.0	11.05.2017	Expansion of the section entitled "Permissible Flow Rate"
1.5.0	16.07.2018	Changes to the "Technical Data", Overview update
1.6.0	09.06.2020	Expansion section " <a href="#">5.3 Installation Instructions for Devices with EHEDG Certification</a> " on page 16 and section " <a href="#">6. Cleaning</a> " on page 18
1.7.0	01.09.2020	Expansion of the section " <a href="#">5.3 Installation Instructions for Devices with EHEDG Certification</a> " on page 16
1.8.0	16.07.2024	Changes to " <a href="#">3. Technical Data</a> " on page 9

### 13.2 EU Declaration of Conformity

The EU declaration of conformity can be found on our website at [www.wenglor.com](http://www.wenglor.com) in the product's separate download area.