

Flow Sensor

2 × Analog Output

FXFF105

Part Number

weFlux² InoxSens



- 2 analog outputs: 4 ... 20 mA
- A single sensor for flow and temperature
- FDA compliant
- Measurement independent of flow direction and instillation position

weFlux² Flow Sensors with two analog outputs simultaneously measure flow velocity and the temperature of aqueous liquids regardless of position and direction of flow. Advantage: The number of measuring points and the diversity of sensor variants are cut in half, and greatest possible flexibility is assured for installation in closed piping systems. The analysis module is integrated into the compact housing.

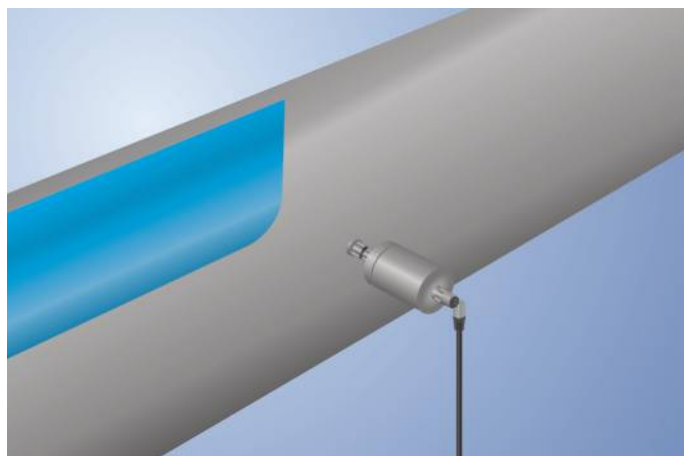

Technical Data

Sensor-specific data	
Measuring Range	10...400 cm/s
Temperature of the medium, flow measurement	0...125 °C**
Temperature of the medium, temperature measurement	-25...150 °C
Setting Range	10...400 cm/s
Medium	Water
Measuring error (total)	≤ 2 %
MTTFd (EN ISO 13849-1)	1210,41 a
Response time in case of temperature jump	10 s
Environmental conditions	
Ambient temperature	-25...80 °C
Storage temperature	-25...80 °C
Pressure Resistance	25 bar
EMC	DIN EN 61326-1
Shock resistance per DIN IEC 68-2-27	30 g / 11 ms
Vibration resistance per DIN IEC 60068-2-6	5 g (10...2000 Hz)
Electrical Data	
Supply Voltage	12...32 V DC
Current Consumption (U _b = 24 V)	< 40 mA
Number of analog outputs	2
Analog Output	4...20 mA
Signal source	Flow
Response Time	1...5 s
Short Circuit Protection	yes
Reverse Polarity Protection	yes
Protection Class	III
Mechanical Data	
Housing Material	1.4404
Material in contact with media	1.4404
Degree of Protection	IP68/IP69K *
Connection	M12 × 1; 4-pin
Process Connection	Clamp diameter: 50,5 mm
Process Connection Length (PCL)	49 mm
Probe Length (PL)	32 mm
Analog output flow	●
Analog output temperature	●
Connection Diagram No.	141
Suitable Connection Equipment No.	2

* Certified by wenglor

** The sensors were calibrated and specified for the medium water. Technically, the sensors are suitable for a medium temperature of up to -25 °C. To achieve a temperature below 0 °C, a different medium must be added to the water. This leads to a different measurement result, which is why an application below 0 °C must be tested individually for the mixture used.

Complementary Products

Software

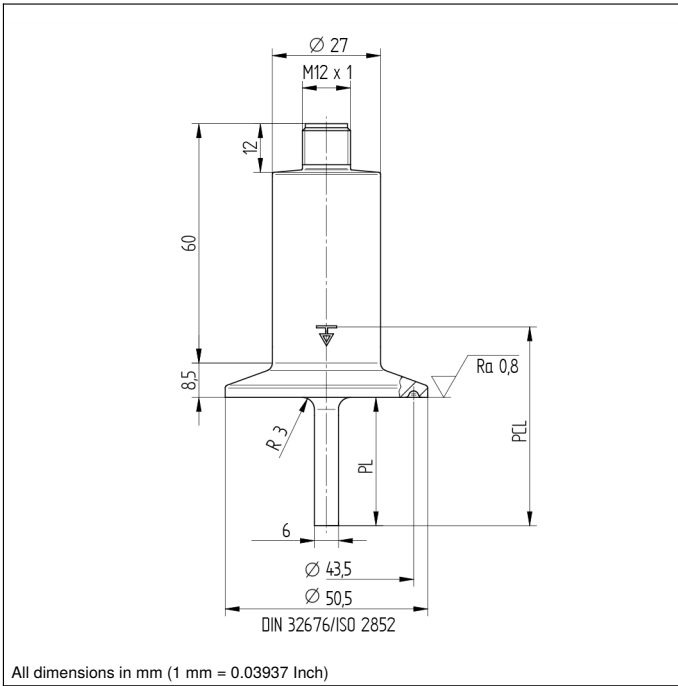

All dimensions in mm (1 mm = 0.03937 Inch)

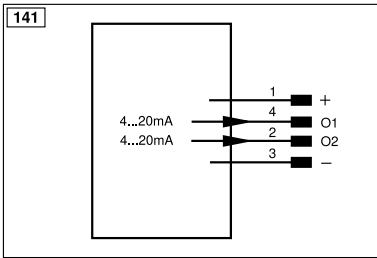

Legend			
+	Supply Voltage +	nc	Not connected
-	Supply Voltage 0 V	U	Test Input
~	Supply Voltage (AC Voltage)	Ü	Test Input inverted
A	Switching Output (NO)	W	Trigger Input
Ā	Switching Output (NC)	W-	Ground for the Trigger Input
V	Contamination/Error Output (NO)	O	Analog Output
ȳ	Contamination/Error Output (NC)	O-	Ground for the Analog Output
E	Input (analog or digital)	BZ	Block Discharge
T	Teach Input	Amv	Valve Output
Z	Time Delay (activation)	a	Valve Control Output +
S	Shielding	b	Valve Control Output 0 V
RxD	Interface Receive Path	SY	Synchronization
TxD	Interface Send Path	SY-	Ground for the Synchronization
RDY	Ready	E+	Receiver-Line
GND	Ground	S+	Emitter-Line
CL	Clock	±	Grounding
E/A	Output/Input programmable	SnR	Switching Distance Reduction
IO-Link		Rx+/-	Ethernet Receive Path
PoE	Power over Ethernet	Tx+/-	Ethernet Send Path
IN	Safety Input	Bus	Interfaces-Bus A(+)/B(-)
OSSD	Safety Output	La	Emitted Light disengageable
Signal	Signal Output	Mag	Magnet activation
BI_D+/-	Ethernet Gigabit bidirect. data line (A-D)	RES	Input confirmation
ENo RS422	Encoder 0-pulse 0/0 (TTL)	EDM	Contactor Monitoring
PT	Platinum measuring resistor	ENARs422	Encoder A/Ā (TTL)
			Encoder B/B̄ (TTL)
			Encoder A
			Encoder B
			Digital output MIN
			Digital output MAX
			Digital output OK
			Synchronization In
			Synchronization OUT
			Brightness output
			Maintenance
			Reserved
			Wire Colors according to DIN IEC 60757
			BK Black
			BN Brown
			RD Red
			OG Orange
			YE Yellow
			GN Green
			BU Blue
			VT Violet
			GY Grey
			WH White
			PK Pink
			GNYE Green/Yellow

