

# Pressure Sensor

## FFXP006

Part Number

InoxSens UniBar



- FDA compliant
- Hygienic design makes it easy to clean
- Piggable with flush mounting
- Robust stainless steel housing with IP69K
- Space-saving process connection thanks to small pressure membrane

UniBar pressure sensors measure the relative pressure in closed systems of any medium in the range -1...600 bar.

UniBar pressure sensors are very easy to use thanks to the removable cover on the integrated display. The highly visible switching status display enables the rapid localization of affected sensors for maintenance processes.

Thanks to the metallic sealing edge on the process connection, no further seals are required.

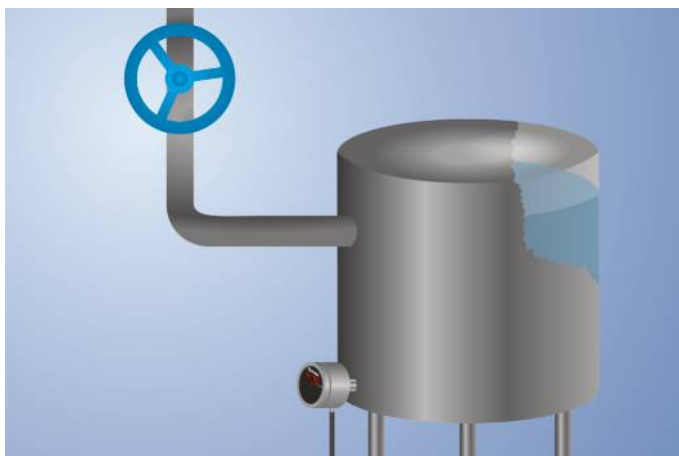

### Technical Data

Sensor-specific data	
Measuring Range	0...40 bar
Measurement Type	relative
Maximum overload pressure	80 bar
Bursting pressure	160 bar
Setting Range	4...100 %
Medium	Liquids, gases
Switching Hysteresis	2 %
Measuring error	< ± 0,5 %
Temperature Drift	0,025 %/K
Environmental conditions	
Temperature of medium	-25...60 °C
Ambient temperature	-25...80 °C
EMC	DIN EN 61326-2-3
Shock resistance per DIN IEC 68-2-27	30 g / 11 ms
Vibration resistance per DIN IEC 60068-2-6	20 g (10...2000 Hz)
Electrical Data	
Supply Voltage	16...32 V DC
Current Consumption (U <sub>b</sub> = 24 V)	< 60 mA
Number of Switching Outputs	1
Response Time	1,2 s
Switching Output/Switching Current	< 250 mA
Switching Output Voltage Drop	< 2 V
Analog Output	0...10 V
Signal source	Pressure
Resolution	10 bit
Short Circuit Protection	yes
Reverse Polarity Protection	yes
Protection Class	III
Mechanical Data	
Setting Method	Menu
Housing Material	1.4404; PC; EPDM
Material Control Panel	Polyester
Material in contact with media	1.4435; 1.4404
Degree of Protection	IP67/IP69K *
Connection	M12 × 1; 4-pin
Process Connection	G 1/2" CIP-capable
Safety-relevant Data	
MTTFd (EN ISO 13849-1)	1201,51 a
Analog Output	●
PNP NO	●
Connection Diagram No.	534
Control Panel No.	A13
Suitable Connection Equipment No.	2
Suitable Mounting Technology No.	905   906

\* Certified by wenglor

## Ctrl. Panel

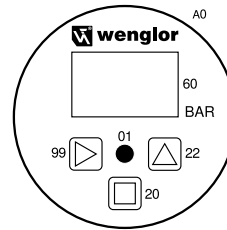
**A13**

- 01 = Switching Status Indicator
- 0A = Detachable lid
- 20 = Enter key
- 22 = Up key
- 60 = display
- 99 = Right button

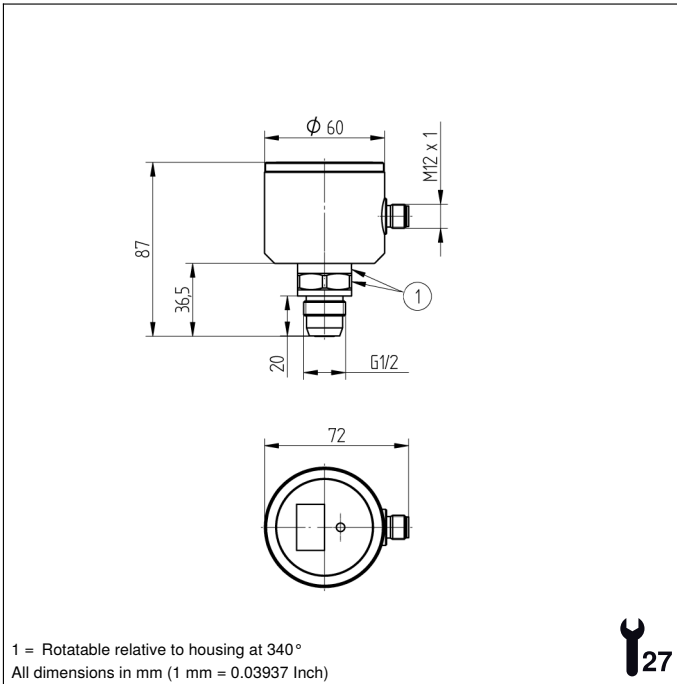

1 = Rotatable relative to housing at 340°  
 All dimensions in mm (1 mm = 0.03937 Inch)

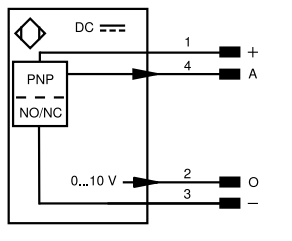
**534**

**Legend**

+	Supply Voltage +	nc	Not connected	ENBRS422	Encoder B/B̄ (TTL)
-	Supply Voltage 0 V	U	Test Input	ENA	Encoder A
~	Supply Voltage (AC Voltage)	Ū	Test Input inverted	ENb	Encoder B
A	Switching Output (NO)	W	Trigger Input	AMIN	Digital output MIN
Ā	Switching Output (NC)	W-	Ground for the Trigger Input	AMAX	Digital output MAX
V	Contamination/Error Output (NO)	O	Analog Output	Aok	Digital output OK
ȳ	Contamination/Error Output (NC)	O-	Ground for the Analog Output	SY In	Synchronization In
E	Input (analog or digital)	BZ	Block Discharge	SY OUT	Synchronization OUT
T	Teach Input	Amv	Valve Output	OLT	Brightness output
Z	Time Delay (activation)	a	Valve Control Output +	M	Maintenance
S	Shielding	b	Valve Control Output 0 V	rsv	Reserved
RxD	Interface Receive Path	SY	Synchronization	Wire Colors according to DIN IEC 60757	
TxD	Interface Send Path	SY-	Ground for the Synchronization	BK	Black
RDY	Ready	E+	Receiver-Line	BN	Brown
GND	Ground	S+	Emitter-Line	RD	Red
CL	Clock	±	Grounding	OG	Orange
E/A	Output/Input programmable	SnR	Switching Distance Reduction	YE	Yellow
IO-Link		Rx+/-	Ethernet Receive Path	GN	Green
PoE	Power over Ethernet	Tx+/-	Ethernet Send Path	BU	Blue
IN	Safety Input	Bus	Interfaces-Bus A(+)/B(-)	VT	Violet
OSSD	Safety Output	La	Emitted Light disengageable	GY	Grey
Signal	Signal Output	Mag	Magnet activation	WH	White
BI_D+/-	Ethernet Gigabit bidirect. data line (A-D)	RES	Input confirmation	PK	Pink
ENo RS422	Encoder 0-pulse 0/0̄ (TTL)	EDM	Contactor Monitoring	GNYE	Green/Yellow
PT	Platinum measuring resistor	ENARs422	Encoder A/Ā (TTL)		

