

# Pressure Sensor

## FFMP056

Part Number

UniBar



- Highly visible output indicator
- Piggable with flush mounting
- Simple operation via the display
- Space-saving process connection thanks to small pressure membrane

UniBar pressure sensors measure the relative pressure in closed systems of any medium in the range -1...600 bar.

UniBar pressure sensors are very easy to use thanks to the integrated display. The highly visible switching status display enables the rapid localization of affected sensors for maintenance processes.

Thanks to the metallic sealing edge on the process connection, no further seals are required.

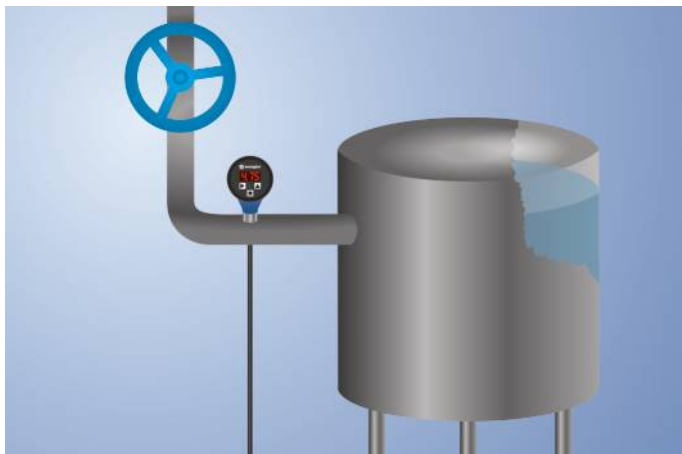

### Technical Data

#### Sensor-specific data

Measuring Range	0...160 bar
Measurement Type	relative
Maximum overload pressure	320 bar
Bursting pressure	640 bar
Setting Range	4...100 %
Medium	Liquids, gases
Switching Hysteresis	2 %
Measuring error	< ± 0,5 %
Temperature Drift	0,025 %/K

#### Environmental conditions

Temperature of medium	-25...80 °C
Ambient temperature	-25...80 °C
EMC	DIN EN 61326-2-3
Shock resistance per DIN IEC 68-2-27	30 g / 11 ms
Vibration resistance per DIN IEC 60068-2-6	20 g (10...2000 Hz)

#### Electrical Data

Supply Voltage	16...32 V DC
Current Consumption (U <sub>b</sub> = 24 V)	< 60 mA
Number of Switching Outputs	1
Response Time	30 ms
Switching Output/Switching Current	< 250 mA
Switching Output Voltage Drop	< 2 V
Analog Output	4...20 mA
Signal source	Pressure
Resolution	10 bit
Current Output Load Resistance	< 500 Ohm
Short Circuit Protection	yes
Reverse Polarity Protection	yes
Protection Class	III

#### Mechanical Data

Setting Method	Menu
Housing Material	PBT; PC; FKM
Material Control Panel	Polyester
Material in contact with media	1.4435; 1.4404
Degree of Protection	IP67 *
Connection	M12 × 1; 4-pin
Process Connection	G 1/2"

#### Safety-relevant Data

MTTFd (EN ISO 13849-1)	1201,51 a
------------------------	-----------

Analog Output	●
PNP NO	●

Connection Diagram No.	<b>533</b>
Control Panel No.	<b>A05</b>
Suitable Connection Equipment No.	<b>2</b>
Suitable Mounting Technology No.	<b>904</b>

\* Certified by wenglor

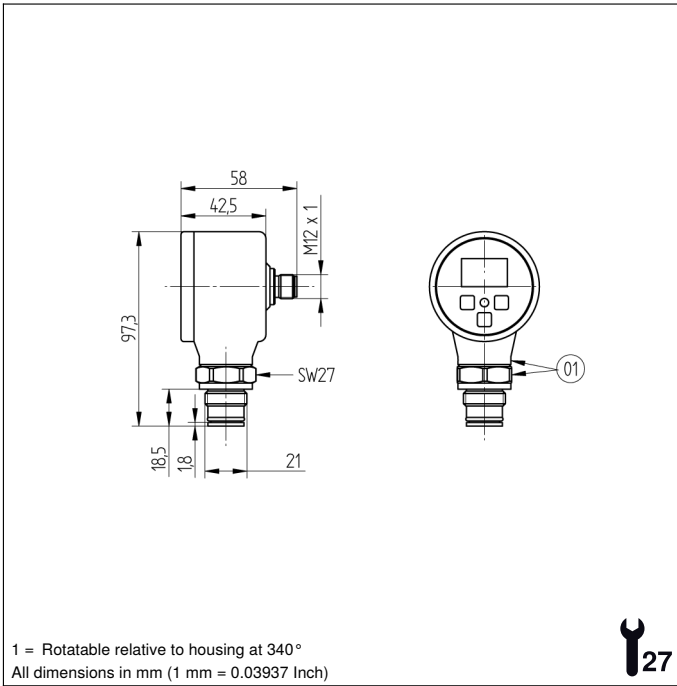

### Ctrl. Panel

A05



- 01 = Switching Status Indicator
- 20 = Enter key
- 22 = Up key
- 60 = display
- 99 = Right button

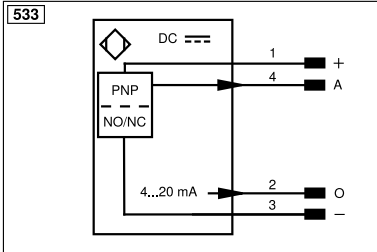

Legend			
+	Supply Voltage +	nc	Not connected
-	Supply Voltage 0 V	U	Test Input
~	Supply Voltage (AC Voltage)	Ū	Test Input inverted
A	Switching Output (NO)	W	Trigger Input
Ā	Switching Output (NC)	W-	Ground for the Trigger Input
V	Contamination/Error Output (NO)	O	Analog Output
ȳ	Contamination/Error Output (NC)	O-	Ground for the Analog Output
E	Input (analog or digital)	BZ	Block Discharge
T	Teach Input	Amv	Valve Output
Z	Time Delay (activation)	a	Valve Control Output +
S	Shielding	b	Valve Control Output 0 V
RxD	Interface Receive Path	SY	Synchronization
TxD	Interface Send Path	SY-	Ground for the Synchronization
RDY	Ready	E+	Receiver-Line
GND	Ground	S+	Emitter-Line
CL	Clock	±	Grounding
E/A	Output/Input programmable	SnR	Switching Distance Reduction
IO-Link		Rx+/-	Ethernet Receive Path
PoE	Power over Ethernet	Tx+/-	Ethernet Send Path
IN	Safety Input	Bus	Interfaces-Bus A(+)/B(-)
OSSD	Safety Output	La	Emitted Light disengageable
Signal	Signal Output	Mag	Magnet activation
BI_D+/-	Ethernet Gigabit bidirect. data line (A-D)	RES	Input confirmation
ENo RS422	Encoder 0-pulse 0/0 (TTL)	EDM	Contactor Monitoring
PT	Platinum measuring resistor	ENARs422	Encoder A/Ā (TTL)
			Encoder B/B̄ (TTL)
			Encoder A
			Encoder B
			Digital output MIN
			Digital output MAX
			Digital output OK
			Synchronization In
			Synchronization OUT
			Brightness output
			Maintenance
			Reserved
			Wire Colors according to DIN IEC 60757
			BK Black
			BN Brown
			RD Red
			OG Orange
			YE Yellow
			GN Green
			BU Blue
			VT Violet
			GY Grey
			WH White
			PK Pink
			GNYE Green/Yellow