

Temperature Sensor

FFAT034

Part Number

UniTemp



- Highly visible output indicator
- Simple operation via the display
- Temperature range: 0...200 °C available

UniTemp temperature sensors measure the temperature of liquid or gaseous media and facilitate the temperature monitoring of processes.

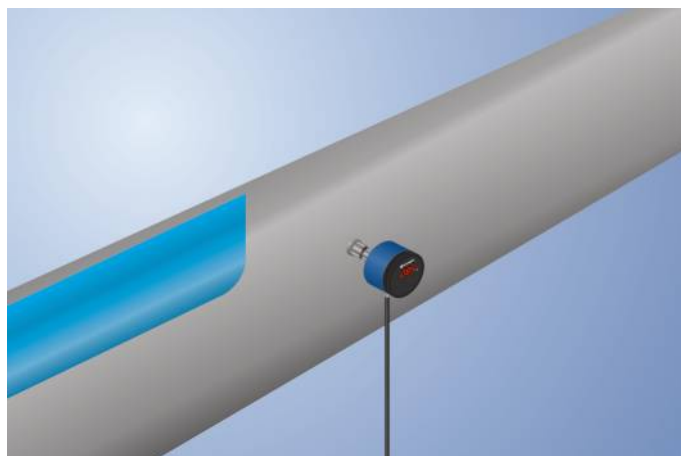

Technical Data

Sensor-specific data

Temperature Measurement Range	0...140 °C
Setting Range	2...139 °C
Medium	Liquids, gases
Measuring error	± 1 °C
Resolution	1 °C
Switching Hysteresis	2 °C
Response Time	2...4 s

Environmental conditions

Temperature of medium	0...140 °C
Ambient temperature	-20...80 °C
Pressure Resistance	60 bar
EMC	DIN EN 61326-2-3
Shock resistance per DIN IEC 68-2-27	30 g / 11 ms
Vibration resistance per DIN IEC 60068-2-6	20 g (10...2000 Hz)

Electrical Data

Supply Voltage	16...32 V DC
Current Consumption (U _b = 24 V)	60 mA
Number of Switching Outputs	1
Analog Output	0...10 V
Signal source	Temperature
Load Current Voltage Output	< 20 mA
Short Circuit Protection	yes
Reverse Polarity Protection	yes
Protection Class	III

Mechanical Data

Setting Method	Menu
Housing Material	PBT; PC; FKM
Material Control Panel	Polyester
Material in contact with media	1.4435; 1.4404; FKM
Degree of Protection	IP67 *
Connection	M12 × 1; 5-pin
Process Connection	Sealing cone M18 × 1,5
Process Connection Length (PCL)	124 mm
Probe Length (PL)	103,5 mm

Safety-relevant Data

MTTFd (EN ISO 13849-1)	766,91 a
------------------------	----------

Analog Output	●
Relay -NO	●

Connection Diagram No.	1003
Control Panel No.	A01
Suitable Connection Equipment No.	35
Suitable Mounting Technology No.	900 901 902

* Certified by wenglor

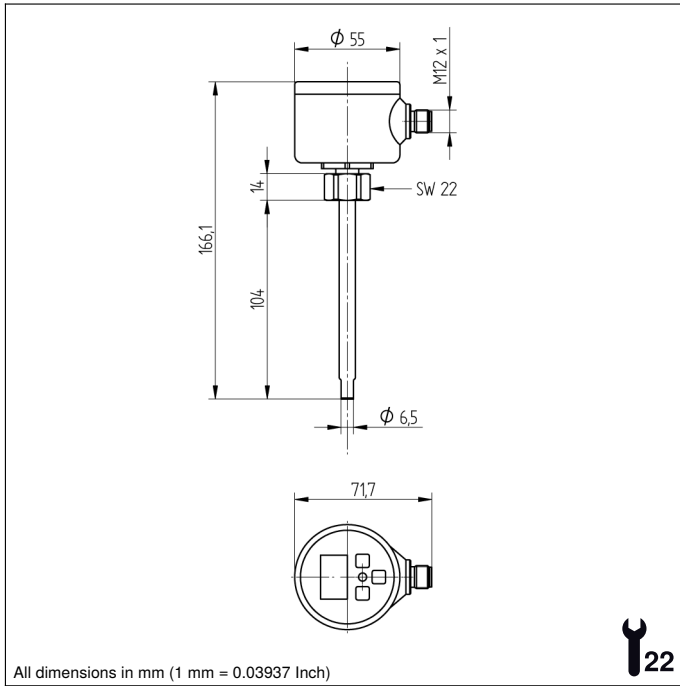

All dimensions in mm (1 mm = 0.03937 Inch)

Ctrl. Panel

A01

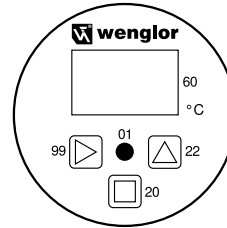

- 01 = Switching Status Indicator
- 20 = Enter key
- 22 = Up key
- 60 = display
- 99 = Right button

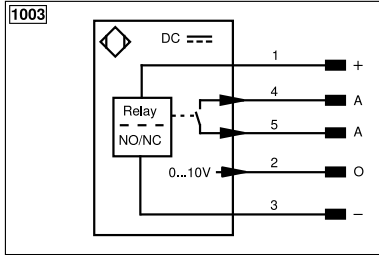

Legend			
+	Supply Voltage +	nc	Not connected
-	Supply Voltage 0 V	U	Test Input
~	Supply Voltage (AC Voltage)	Ü	Test Input inverted
A	Switching Output (NO)	W	Trigger Input
Ā	Switching Output (NC)	W-	Ground for the Trigger Input
V	Contamination/Error Output (NO)	O	Analog Output
ȳ	Contamination/Error Output (NC)	O-	Ground for the Analog Output
E	Input (analog or digital)	BZ	Block Discharge
T	Teach Input	Amv	Valve Output
Z	Time Delay (activation)	a	Valve Control Output +
S	Shielding	b	Valve Control Output 0 V
RxD	Interface Receive Path	SY	Synchronization
TxD	Interface Send Path	SY-	Ground for the Synchronization
RDY	Ready	E+	Receiver-Line
GND	Ground	S+	Emitter-Line
CL	Clock	±	Grounding
E/A	Output/Input programmable	SnR	Switching Distance Reduction
IO-Link		Rx+/-	Ethernet Receive Path
PoE	Power over Ethernet	Tx+/-	Ethernet Send Path
IN	Safety Input	Bus	Interfaces-Bus A(+)/B(-)
OSSD	Safety Output	La	Emitted Light disengageable
Signal	Signal Output	Mag	Magnet activation
BI_D+/-	Ethernet Gigabit bidirect. data line (A-D)	RES	Input confirmation
ENo RS422	Encoder 0-pulse 0/0 (TTL)	EDM	Contactor Monitoring
PT	Platinum measuring resistor	ENARs422	Encoder A/Ā (TTL)
			Encoder B/B̄ (TTL)
			Encoder A
			Encoder B
			Digital output MIN
			Digital output MAX
			Digital output OK
			Synchronization In
			Synchronization OUT
			Brightness output
			Maintenance
			Reserved
			Wire Colors according to DIN IEC 60757
			BK Black
			BN Brown
			RD Red
			OG Orange
			YE Yellow
			GN Green
			BU Blue
			VT Violet
			GY Grey
			WH White
			PK Pink
			GNYE Green/Yellow

